

## Mid-Century Modern Pushback Recliner

### ASSEMBLY INSTRUCTIONS

#### **Before You Begin:**

Please identify all component parts and hardware pieces required before you begin. Carefully remove all of the components from the packaging and set aside for assembly. Assemble on a soft surface to prevent scratching during assembly.

#### **Caution:**

Tighten all components securely before use. Failure to do so may result in personal injury. DO NOT use any sharp objects to open plastic wrapped components as damage to product or components may result.

#### **Warning:**

CHOKING HAZARD - Small Parts. Adult Assembly Required.

Injury may result from tipping furniture. You must install the Tipping Restraint Hardware with the unit to prevent the unit from tipping and causing any accidental injury, instability, death or damage. The tipping restraint is intended only as a safety measure, it is not a substitute for proper adult supervision.

This tipping restraint is not an earthquake restraint. If you wish to add the extra security of earthquake restraints, they must be purchased and installed separately.

Serious or fatal crushing injuries can occur from furniture tipping over. To prevent furniture from tipping over it must be permanently fixed to the wall. Fixing devices for the wall are not included since different wall materials require different types of fixing devices. Use fixing devices suitable for the walls in your home.

Failure to detach this restraint before moving furniture may result in injury or damage.

DO NOT ALLOW CHILDREN TO CLIMB ON FURNITURE

Online Assembly Instructions: <http://ftp.flashfurniture.com/AssemblyInstructions/SG-SX-80415N-BR-GG.pdf>

Customer Service Email: [CustomerExperience@belnick.com](mailto:CustomerExperience@belnick.com) | Phone: 866-552-2810

SG-SX-80415N-BR-GG / SG-SX-80415N-GY-GG

## **Have a Question/Concern?**

Quality products and first-class customer service are the cornerstone of long-lasting consumer relationships. We strive toward excellence in all we do and want you to be completely satisfied with your purchase.

**Please contact our exceptional Customer Experience Agents at the email address or phone number shown below to assist you with any product questions or issues before requesting a return.**

We look forward to serving you in a friendly, efficient manner to resolve any issues you may have.

**Customer Service Email: [CustomerExperience@belnick.com](mailto:CustomerExperience@belnick.com)**

**Customer Service Phone: 866-552-2810**

## **Our Warranty Statement**





This warranty covers manufacturing defects associated with your new product. The product is warranted from the original purchase date and to the original purchaser for normal usage, according to the below-referenced specifications and limitations.

- Non-moving metal parts are warranted for 5 years.
- Component parts including pneumatic cylinder, control mechanism, base and casters are warranted for 2 years.
- All other items are warranted for 1 year.

Normal usage means use in compliance with the restrictions and weight limits specified for the product. In the absence of product-specific restrictions and weight limits, normal usage means use for no more than forty hours per week by persons weighing 250 lbs. or less. Coverage terminates if the product is sold or otherwise transferred. Repairs made by parties other than Belnick also void this warranty.

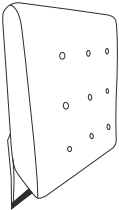
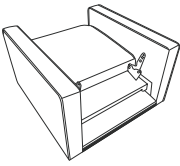
This warranty will not cover: (1) labor, freight, or damage from misuse, abuse, negligence, alteration, assembly, installation, attachments, accident, vandalism, acts of nature or any other event beyond the control of Belnick; (2) tearing, scratching, scuffing, or blemishing of leather or fabric; (3) cosmetic damage that may result from normal usage; (4) damage attributable to use by persons exceeding specified weight limits or commercial use exceeding forty hours per week; or (5) rust or other damage caused by exposure to moisture. The user assumes all risk of injury resulting from use of this product. Liability for incidental or consequential damage is excluded. Some states do not allow the exclusion or limitation of incidental or consequential damages, so the above limitation or exclusion may not apply to you.

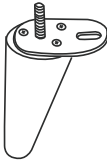
# PARTS

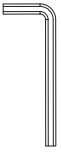
(1)	(2)	(3)	(4)A	(4)B	(5)	(6)
						
BACK CUSHION X1PC	SEAT FRAME X1PC	PLASTIC WASHER X4PCS	REAR FOOT X2PCS	FRONT FOOT X2PCS	BOLT X2PCS	ALLEN WRENCH X1PC

## STEP 1

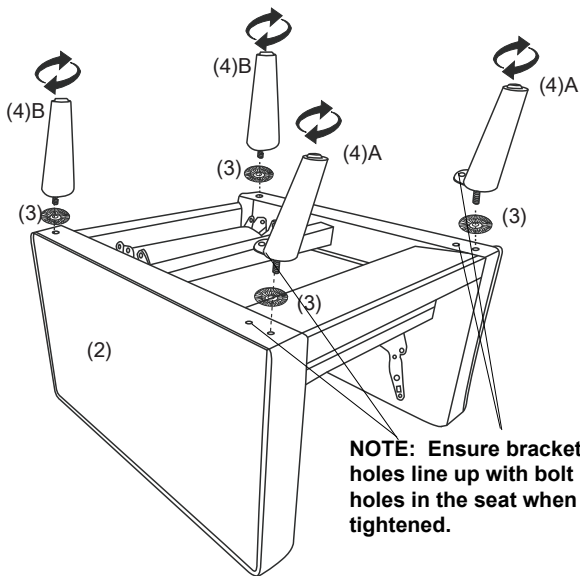

**NOTE:** Ensure bracket holes line up with bolt holes in the seat when tightened.

Using Plastic Washers (Part 3) x 4, attach Rear Feet (Part 4A) x 2 & front feet (Part 4B) x 2 by rotating clockwise to tighten.

## STEP 2

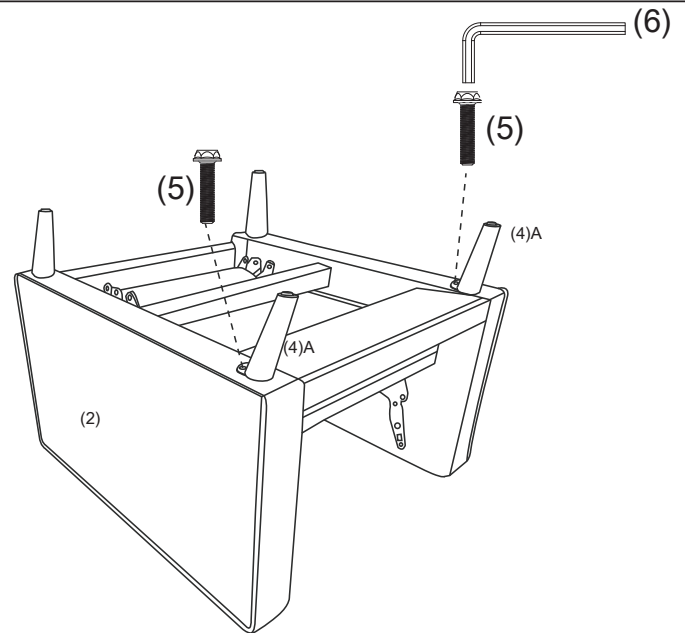

Attach 2 rear feet (Part 4A) to seat frame (Part 2) using Bolts (Part 5) x 2. Use Allen Wrench (Part 6) to tighten the bolts.

## STEP 3

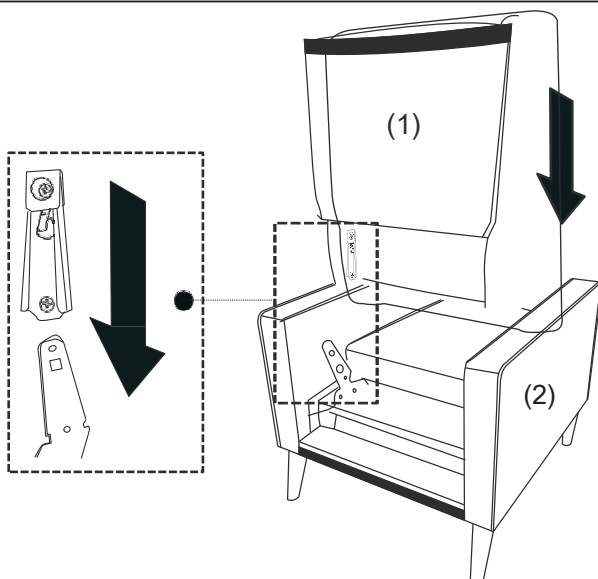

Slide the metal brackets on back cushion (Part 1) into the metal glides on seat frame (Part 2). Lower the back cushion onto the seat frame until it locks into place. Pull down the fabric flap and using the hook and loop system.

## STEP 4

