

"SICILIAN" FIREPLACE

FA927500TX-IVORY

FA927600TX-BLACK

FA927700TX-MAHOGANY

ASSEMBLY INSTRUCTION



Southern
ENTERPRISES

For assistance with assembly contact:
Southern Enterprises Inc.

Customer Service 1-800-633-5096

service@seidal.com

www.seidal.com

PO#12831

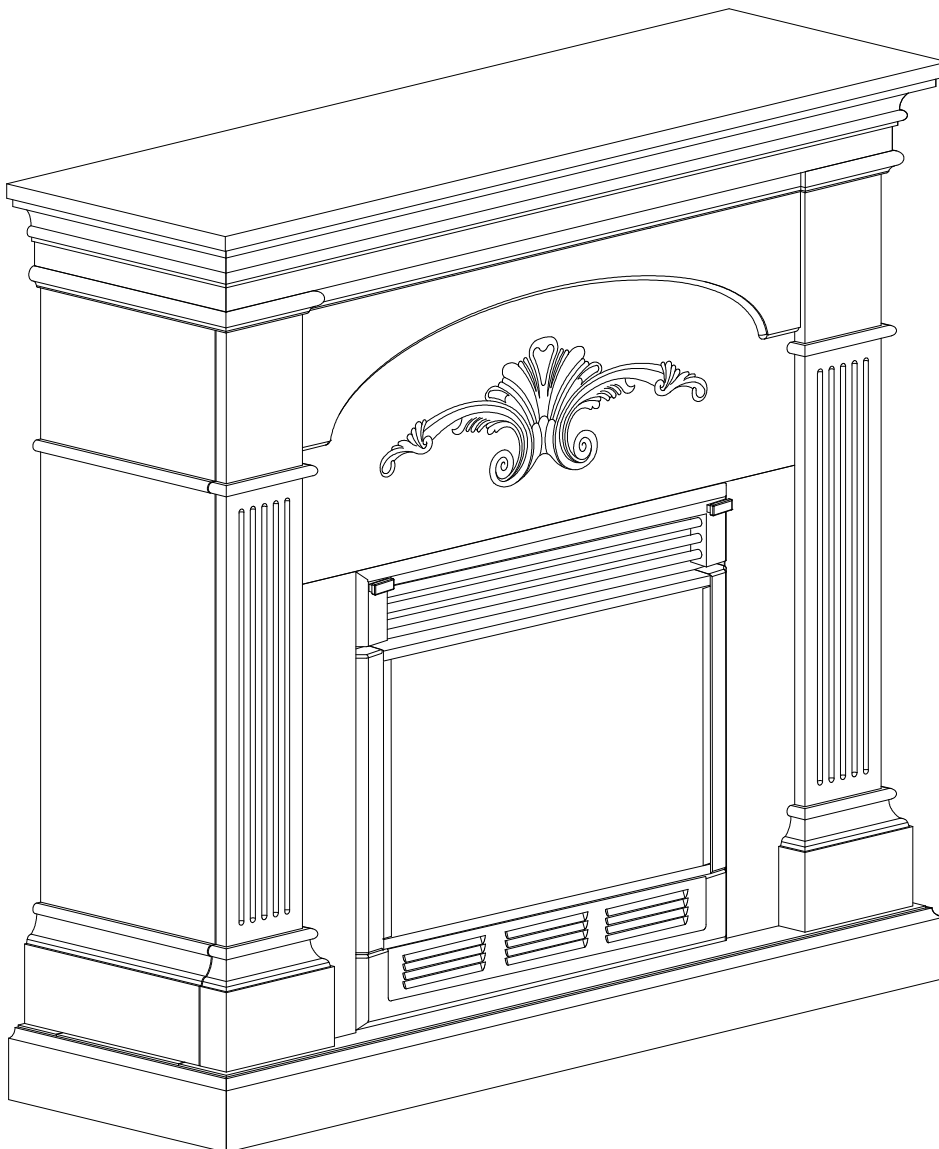

"SICILIAN" FIREPLACE

Parts List

Please review all parts and hardware before disposing of any packaging.
Call Customer Service if missing hardware. Using a screw that is too long will cause damage. Before beginning assembly, separate each type of screw. Carefully study the diagrams below. You may receive extra hardware with your unit.

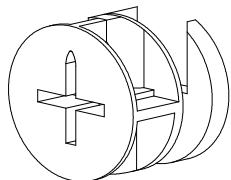
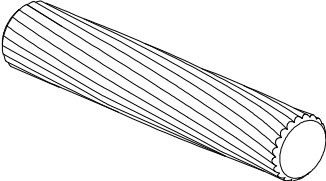
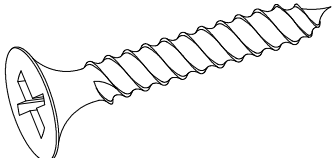
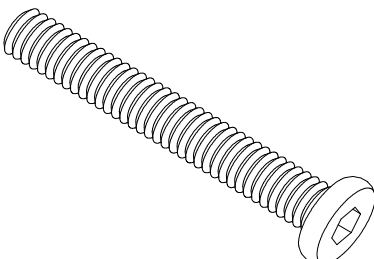
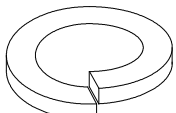
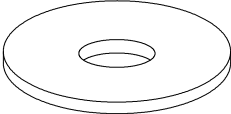
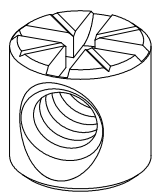
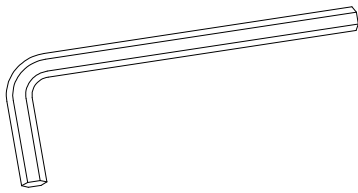
A  CAM BOLT	B  CAM LOCK
C  WOOD DOWEL	D  WOOD SCREW
E  SOCKET HEXAGON SCREW	F  SPRING WASHER
G  FLAT WASHER	H  CROSS SOCKET NUT
I  ALLEN WRENCH	

"SICILIAN" FIREPLACE Parts List

Please review all parts and hardware before disposing of any packaging.
Call Customer Service if missing hardware. Using a screw that is too long will cause damage. Before beginning assembly, separate each type of screw. Carefully study the diagrams below. You may receive extra hardware with your unit.

(1)

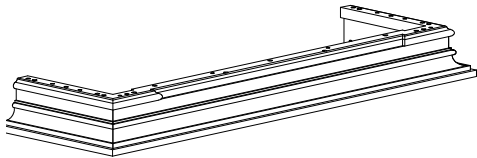

TOP PANEL

Quantity
of 1

(2)

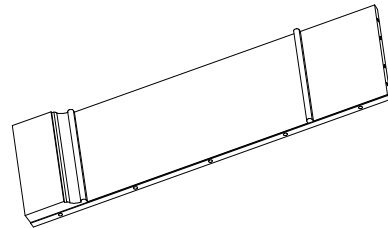

SIDE PANEL

Quantity
of 2

(3)

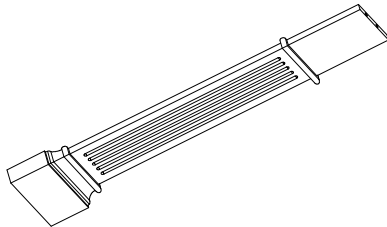

SIDE FRONT PANEL

Quantity
of 2

(4)

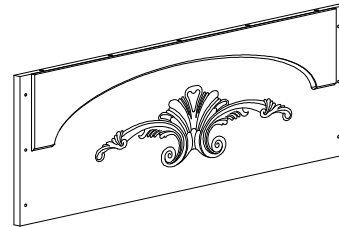

FRONT UPPER CROSS PANEL

Quantity
of 1

(5)

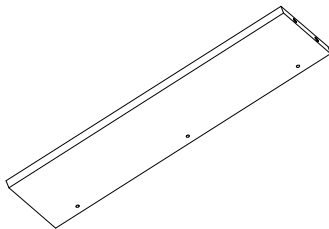

SIDE BLOCK FIRE PANEL(L&R)

Quantity
of 2

(6)

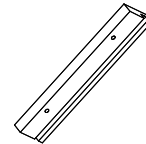

INNER FIXED BAR

Quantity
of 2

(7)

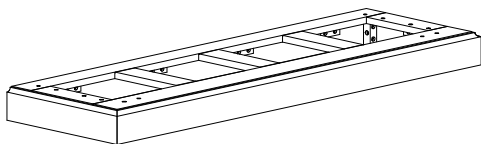

BASE

Quantity
of 1

(8)

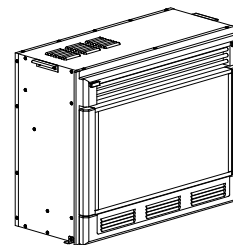

INSERT (sold in a separate carton)

Quantity
of 1

Care and Cleaning Instructions:

Before using, wipe with a clean, dry cloth. Periodically apply furniture wax to renew the finish. Avoid rubbing or scratching the surface with rough or abrasive objects.

Call Customer Service at 1-800-633-5096 if there are missing or damaged parts.

Please call manufacturer for assistance, questions or Parts.

Assembly Tool Required
No.2 Phillips Screwdriver (Not Included)

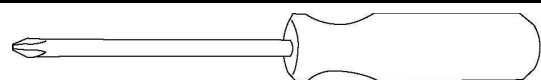

"SICILIAN" FIREPLACE Assembly Instructions

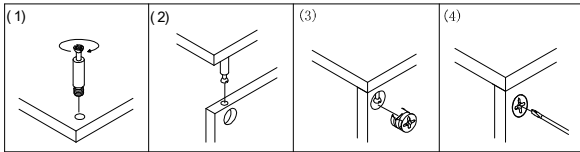

"Please do not over tighten cambolts. Please stop when you feel tight"

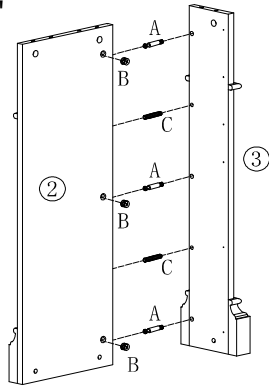

Figure 1

INSERT (A) CAM BOLT & (C) WOOD DOWEL TO PRE-DRILLED HOLES, THEN USE B) CAM LOCK TO ATTACH (2) SIDE PANEL & (3) SIDE FRONT PANEL.

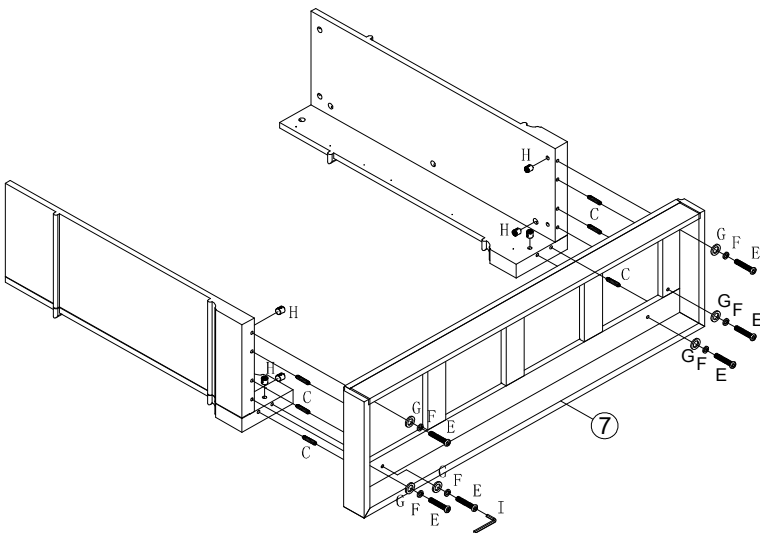

Figure 2

INSERT (C) WOOD DOWEL & (H) CROSS SOCKET NUT TO CORRESPONDING HOLES. INSERT (E) SOCKET HEXAGON SCREW THROUGH (F) SPRING WASHER & (G) FLAT WASHER FROM BOTTOM OF THE BASE TO CONNECT THE BASE TO SIDE PANELS.

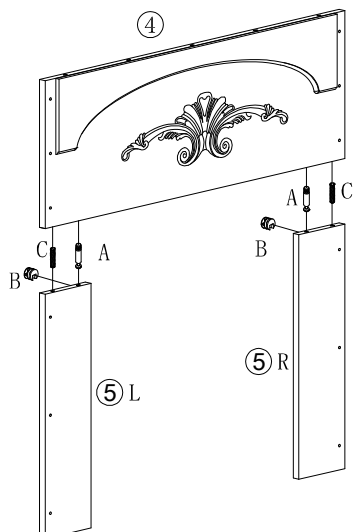

Figure 3

INSERT (B) CAM LOCK INTO CORRESPONDING HOLES ON THE INSIDE OF (5) SIDE BLOCK FIRE PANEL. ATTACH (A) CAM BOLT & (C) WOOD DOWEL INTO CORRESPONDING HOLES ON (4) FRONT UPPER CROSS PANEL. TIGHTEN CAMLOCKS USING PHILLIPS SCREW DRIVER.

"SICILIAN" FIREPLACE Assembly Instructions

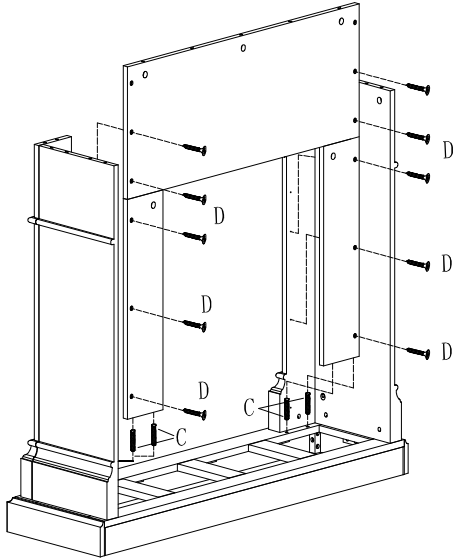

Figure 4

INSERT (C) WOOD DOWEL TO CORRESPONDING HOLES ON BASE THEN PUSH THE PRE-ASSEMBLED UNIT FROM FIGURE (3) TO THE BACK OF SIDE OF FRONT PANEL. THEN INSERT (D) WOOD SCREW TO CORRESPONDING HOLES TO ATTACH (3) SIDE FRONT PANEL. TIGHTEN ALL SCREWS WITH SCREW DRIVER.

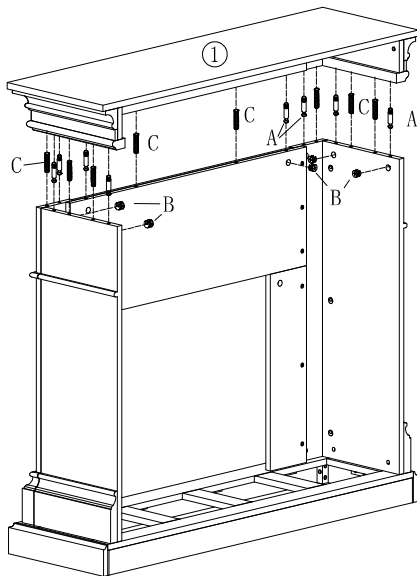

Figure 5

INSERT (A) CAM BOLT & (C) WOOD DOWEL INTO CORRESPONDING HOLES ON TOP PANEL. FIT TOP PANEL INTO PRE-ASSEMBLED UNIT FROM FIGURE 4. INSERT (B) CAM LOCK INTO PRE-ASSEMBLED UNIT FROM FIGURE 4, THEN TIGHTEN ALL CAMLOCKS TO SECURE THE TOP.

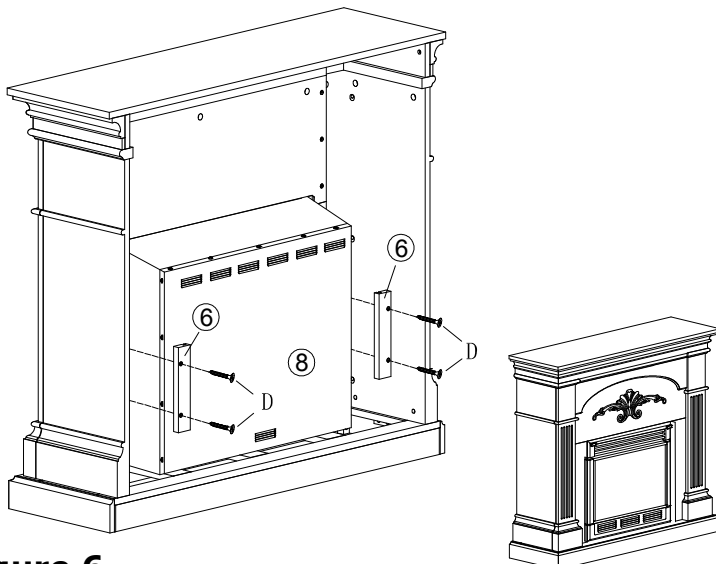

Figure 6

PUSH (FIREBOX) INSERT FROM THE BACK. ATTACH (6) INNER FIXED BAR ON THE LEFT/RIGHT GROOVE OF FIREBOX INSERT. SECURE FIXED BAR WITH SCREW DRIVER.

Parts Replacement Form

Customer Information

Name _____

Address _____

City/State/Zip Code _____

Phone Number _____

Please indicate where you purchased this item: Store/Website/Catalog

Please indicate color/size/style number:

Style No	Parts Letter	Parts Description	Quantity Needed
_____	_____	_____	_____
_____	_____	_____	_____
_____	_____	_____	_____

Please immediately examine this product carefully. Any request for missing parts or damage replacement must be received within 90 days of your receipt of the product. Replacement, if available, will be honored within this time frame. Parts will not be available for items arriving fully assembled. We do not recommend modifying product(s) and we are not responsible for any damages due to product modification(s). If damages or missing parts are not reported within 90 days of your receipt, we are under no obligation to provide parts or replacement merchandise.

Please contact Southern Enterprises at 800-633-5096 or in Dallas 972-869-0111/ 9am – 4pm Mon-Fri Central time if you have product issues or email us at service@seidal.com. Please ask for customer service representative for issues involving damages or replacement parts. Please ask for technical assistance representative for any issues with product and assembly/construction.

Please contact the retailer that you purchased from for returns.

Customer Service 1-800-633-5096
service@seidal.com

Southern Enterprises, Inc.
600 Freeport Parkway, Suite 200
Coppell, Texas 75019



Southern
ENTERPRISES