

Final trim size(WxH): 8.27" x 11.69" (210 x 269.9 mm).



NS-UZ53WH9 Product Name: V1 Final Page 1 Wednesday, December 6, 2017 10:10 AM



USER GUIDE

5.3 Cu. Ft. Upright Freezer – White

NS-UZ53WH9

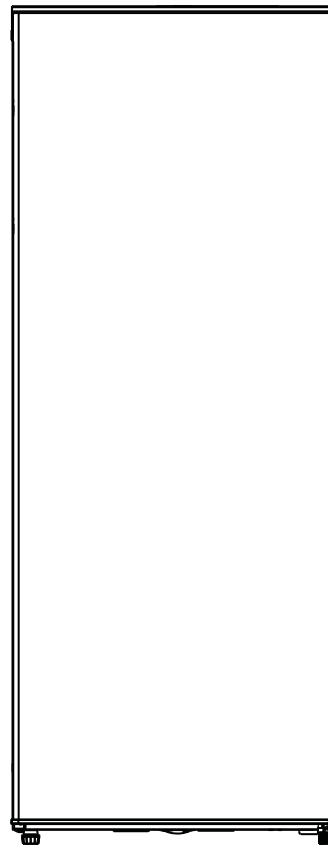

Before using your new product, please read these instructions to prevent any damage.



Contents

Introduction	3
Important Safety Instructions	3
Grounding requirement	4
Features	5
Package contents	5
Dimensions	5
Interior	6
Setting up your freezer	6
Before using your freezer	6
Finding a suitable location	7
Leveling your freezer	8
Reversing the freezer door	9
Providing the correct power source	12
Using your freezer	12
Cleaning your freezer	13
Defrosting your freezer	13
Storing your freezer	13
Moving your freezer	13
Tips on saving energy	13
Troubleshooting	14
Specifications	15
ONE-YEAR LIMITED WARRANTY	16

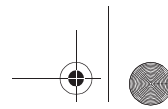

5.3 Cu. Ft. Upright Freezer – White

Introduction

Congratulations on your purchase of a high-quality Insignia product. Your NS-UZ53WH9 represents the state of the art in upright freezer design and is designed for reliable and trouble-free performance.

Important Safety Instructions



This symbol indicates that dangerous voltage constituting a risk of electric shock is present within your freezer.



This symbol indicates that there are important operating and maintenance instructions in the literature accompanying your freezer.

WARNING

- 1 Read these instructions.
- 2 Keep these instructions.
- 3 Heed all warnings.
- 4 Follow all instructions.
- 5 Do not use this appliance near water.
- 6 Clean only with a damp cloth or sponge using a non-corrosive, neutral detergent. Remove residual detergent with clear water.
- 7 Do not block any ventilation openings.
- 8 Install in accordance with the manufacturer's instructions.
- 9 Do not install near any heat sources, such as radiators, heat registers, stoves, or other apparatus that produce heat.
- 10 Do not defeat the safety purpose of the polarized or grounding-type plug. A polarized plug has two blades with one wider than the other. A grounding type plug has two blades and a third grounding prong. The wide blade or the third prong are provided for your safety. If the provided plug does not fit into your outlet, consult an electrician for replacement of the obsolete outlet.
- 11 Protect the power cord from being walked on or pinched, particularly at plugs, convenience receptacles, and the point where it exits from the appliance.
- 12 Do not attempt to modify or extend the power cord of your freezer.
- 13 Unplug your freezer during lightning storms or when it will not be used for long periods of time.
- 14 Make sure that the available AC power matches the voltage requirements of your freezer.
- 15 Do not handle the plug with wet hands. This could result in an electric shock.
- 16 Unplug the power cord by holding the plug, never by pulling the cord.
- 17 Refer all servicing to qualified service personnel. Servicing is required when your freezer has been damaged in any way, such as the power-supply cord or plug is damaged, liquid has been spilled or objects have fallen into your freezer, your freezer has been exposed to rain or moisture, does not operate normally, or has been dropped.
- 18 To reduce the risk of fire or electric shock, do not expose your freezer to rain, moisture, dripping, or splashing, and no objects filled with liquids should be placed on top of it.
- 19 Do not use extension cords or ungrounded (two prong) adapters. If the power cord is too short, have a qualified electrician install an outlet near your freezer. Use of an extension cord can negatively affect your freezer's performance.
- 20 Your freezer is not intended for use by persons (including children) with reduced physical, sensory, or mental capabilities, or lack of experience and knowledge, unless they have been given supervision or instruction concerning use of your freezer by a person responsible for their safety.
- 21 Children should be supervised to ensure that they do not play with your freezer.
- 22 If the power cord is damaged, it must be replaced by the manufacturer, its service agent, or similarly qualified person, in order to avoid a hazard.

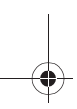
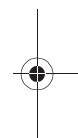
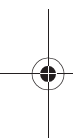

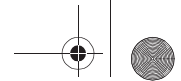

INSIGNIA™

5.3 Cu. Ft. Upright Freezer – White



WARNING

Electric Shock Hazard

Failure to follow these instructions can result in electric shock, fire, or death.

- 1 **WARNING**—Keep ventilation openings, in both your freezer and the built-in structure, clear of obstruction.
- 2 **WARNING**—Do not touch the interior of your freezer with wet hands. This could result in frostbite.
- 3 **WARNING**—Do not use mechanical devices or other means to accelerate the defrosting process, other than those recommended by the manufacturer.
- 4 **WARNING**—Do not damage the refrigerant circuit.
- 5 **WARNING**—Do not damage the refrigerant tubing when handling, moving, or using your freezer.
- 6 **WARNING—DANGER**—Never allow children to play with, operate, or crawl inside your freezer.
Risk of child entrapment. Before you throw away your old freezer:
 - Take off the doors.
 - Leave the shelves in place so that children may not easily climb inside.
- 7 Unplug your freezer before carrying out user maintenance on it.
- 8 If a component part is damaged, it must be replaced by the manufacturer, its service agent, or similar qualified persons in order to avoid a hazard.
- 9 Follow local regulations regarding disposal of your freezer due to flammable refrigerant and gas. All refrigeration products contain refrigerants, which under the guidelines of federal law must be removed before disposal. It is the consumer's responsibility to comply with federal and local regulations when disposing of this product.
- 10 Your freezer is intended to be used in household and similar environments.
- 11 Do not store or use gasoline or any flammable liquids inside or in the vicinity of your freezer.
- 12 **WARNING** - Do not use mechanical devices or other means to accelerate the defrosting process, other than those recommended by the manufacturer.

Grounding requirement

Your freezer must be grounded. Your freezer is equipped with a cord having a grounding wire with a grounding plug. The plug must be inserted into an outlet that is correctly installed and grounded.

Incorrect use of the grounding plug can result in a risk of electric shock. Consult a qualified electrician or service person if the grounding instructions are not completely understood, or if doubt exists as to whether your freezer is correctly grounded.

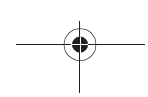



NS-UZ53WH9

Features

Package contents

- 5.3 cubic foot upright freezer
- *User Guide*

Dimensions

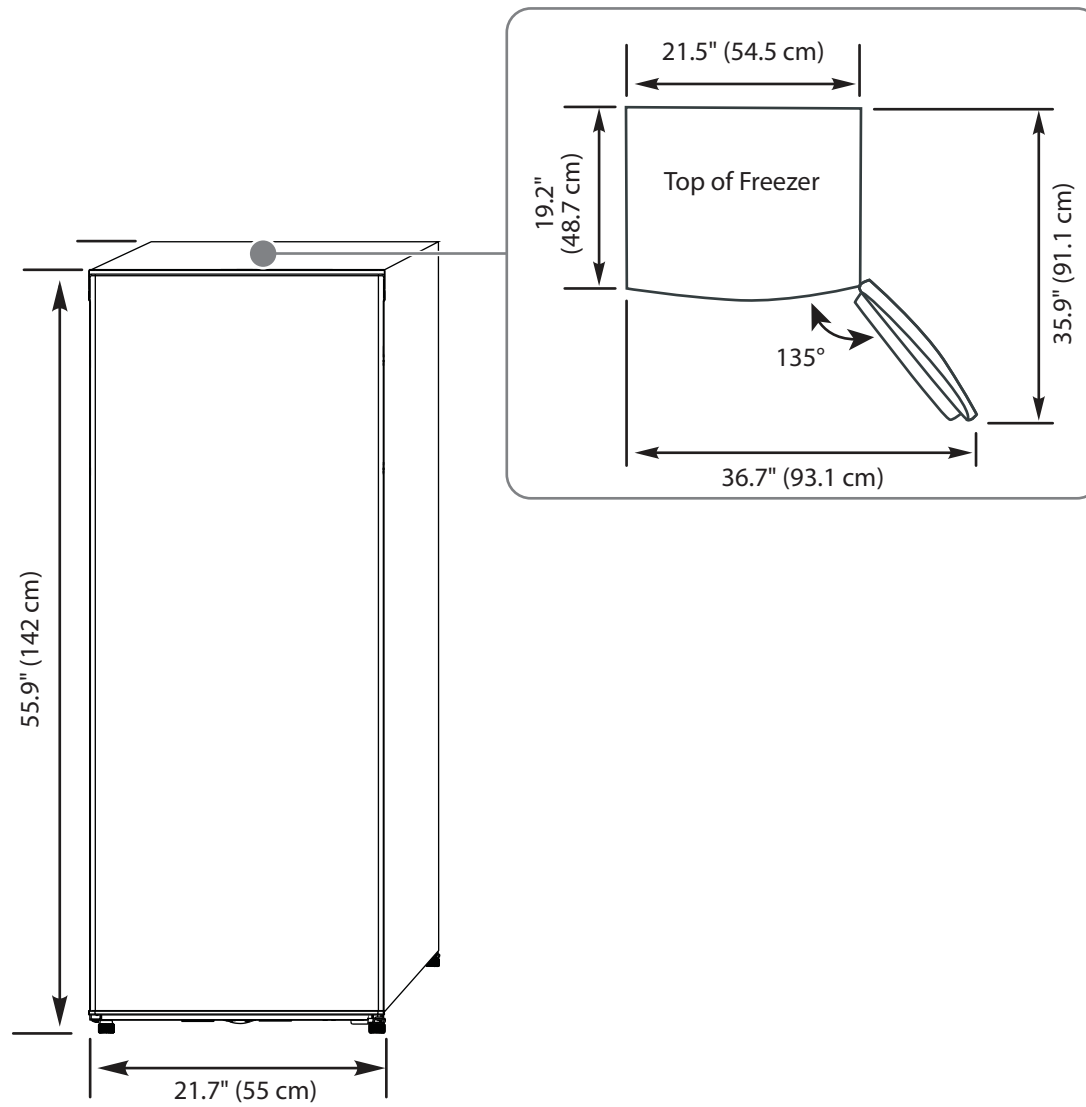

INSIGNIA™

5.3 Cu. Ft. Upright Freezer – White

Interior**Note**

The illustrations shown in this user guide are only for reference. The actual product may differ slightly.

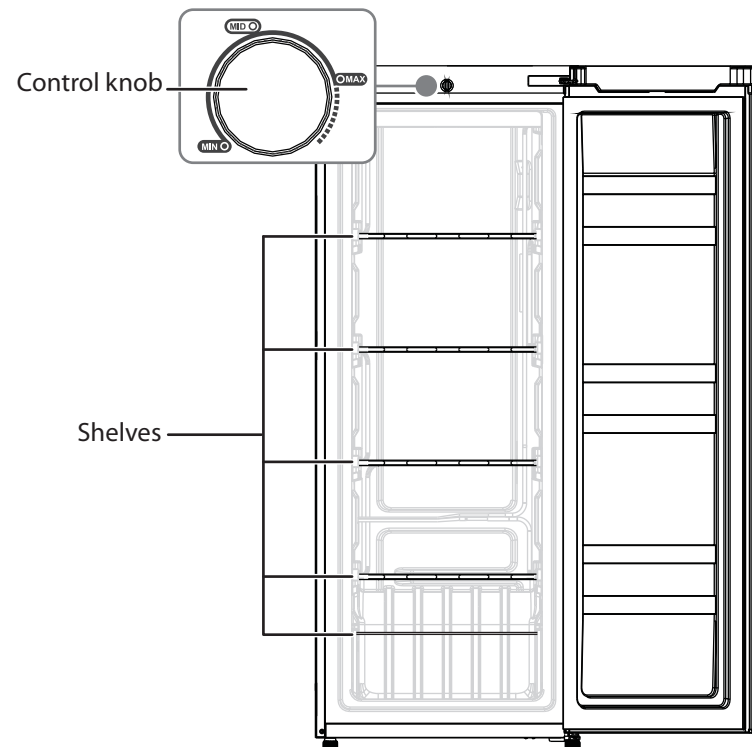
**Notes**

- The four upper shelves measure 14.9 × 12.6" (37.8 × 32.1 cm) (W × D)
- The bottom shelf measures 15.2 × 6.6" (38.5 × 16.8 cm) (W × D)
- You can remove the bottom shelf.

Setting up your freezer**Before using your freezer**

- Remove the exterior and interior packing including the bottom cushions, foam pads, and tape inside your freezer. Remove the plastic film from the door and sides.
- Let your freezer stand upright for approximately 30 minutes before connecting it to power. This reduces the possibility of a malfunction in the cooling system from incorrect handling during transportation.
- Before putting any fresh or frozen foods, let your freezer run for two to three hours. If the ambient temperature is high, for example in summer, wait for four or more hours.
- Wash the inside with a damp, warm cloth and a baking soda solution (two tablespoons in a quart of water), then wipe dry with a dry cloth. Do this periodically to keep your freezer looking new.
- For correct operation, you should level your freezer using the leveling feet. If you do not level your freezer, the door may not close or seal correctly, causing cooling, frost, and moisture problems. Turn the leveling feet clockwise to raise or counterclockwise to lower a side. The leveling feet are easier to adjust if you have someone push against the top of your freezer to take some weight off.
- When moving your freezer, do not tilt it beyond 45° from upright.

Finding a suitable location

- Place your freezer on a floor that is strong enough to support your freezer when it is fully loaded.
- Do not install your freezer on carpeting or a rug.
- Your freezer is designed to be free standing and should not be recessed or built-in.
- If you use your freezer in a garage, make sure that the ambient temperature is between 5°F and 190°F (-15°C and 43°C).
- Allow 3.9 inches (20 cm) of space between the sides of your freezer and the surrounding walls, 3.9 inches (10 cm) between the back of your freezer and the wall, and 11.8 inches (30 cm) between the top of your freezer and the ceiling. This allows for correct air ventilation. Adjust the feet to keep your freezer level.
- If you locate your freezer next to a fixed wall, allow sufficient space on the hinge side for the door to swing open.
- Position your freezer away from direct sunlight and sources of heat, such as a stove, heater, or radiator. Direct sunlight may affect the acrylic coating and heat sources may increase electrical consumption. Extremely cold temperatures may also prevent your freezer from performing correctly.
- Avoid locating your freezer in moist areas.

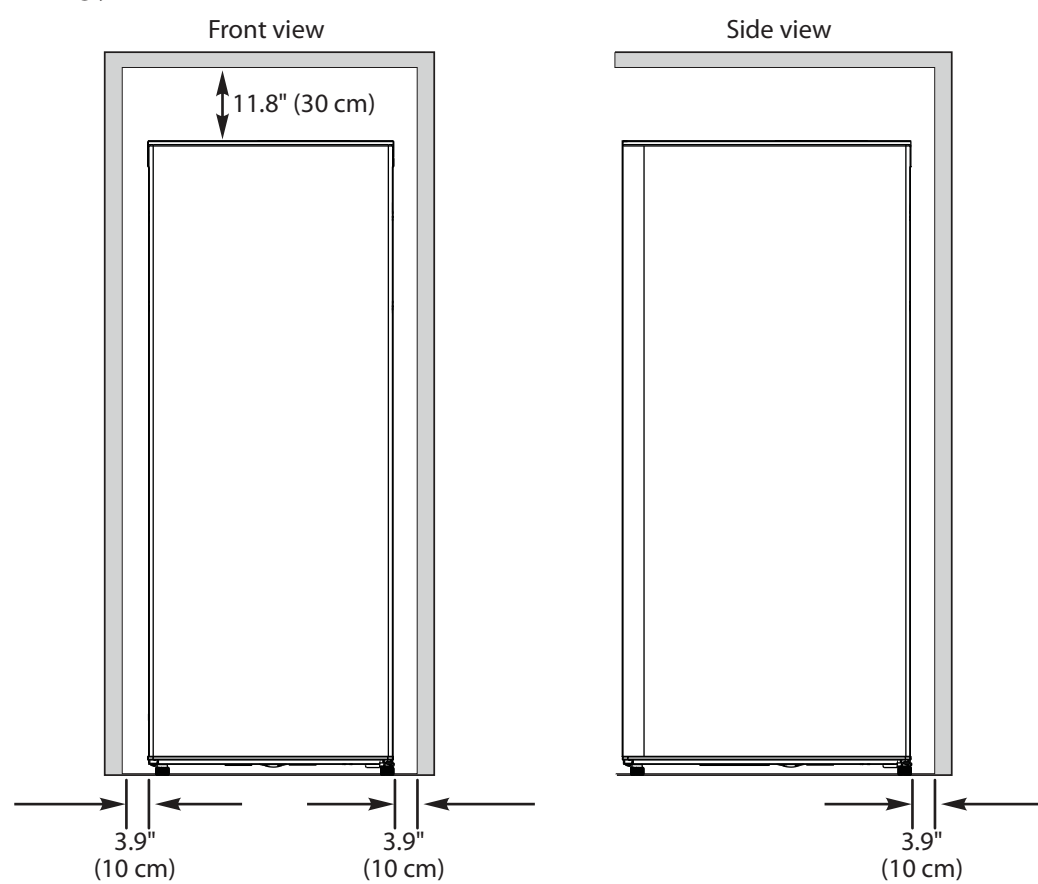

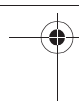
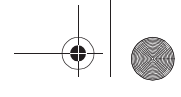

INSIGNIA™

5.3 Cu. Ft. Upright Freezer – White

Leveling your freezer

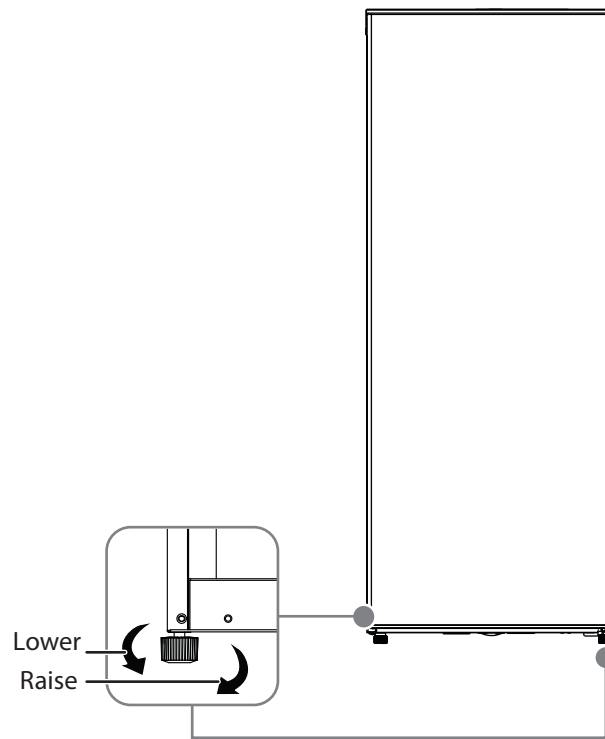

- Leveling your freezer is important. If you do not level your freezer during installation, the doors may not close or seal correctly which can cause cooling, frost, or moisture problems.
- To level your freezer, rotate the leveling feet clockwise (to raise) your freezer or counter-clockwise (to lower).

Note

To make it easier to adjust the feet, have someone push against the top of your freezer to tilt it slightly.

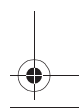
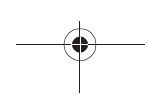
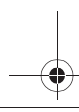

Reversing the freezer door

Warnings

- Unplug your freezer before you reverse the door. Failure to unplug your freezer may result in serious injury or death from electrical shock.
- To avoid personal injury and property damage, get another person to help you reverse the door.

You will need the following tools to reverse the freezer door:

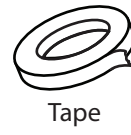
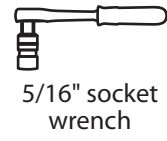

- 1 Unplug your freezer.
- 2 Remove the hinge cover, then remove the top hinge screws and hinge from your freezer. Remove the pin from the top edge of the door, then remove the hole cover from the other side of the freezer.

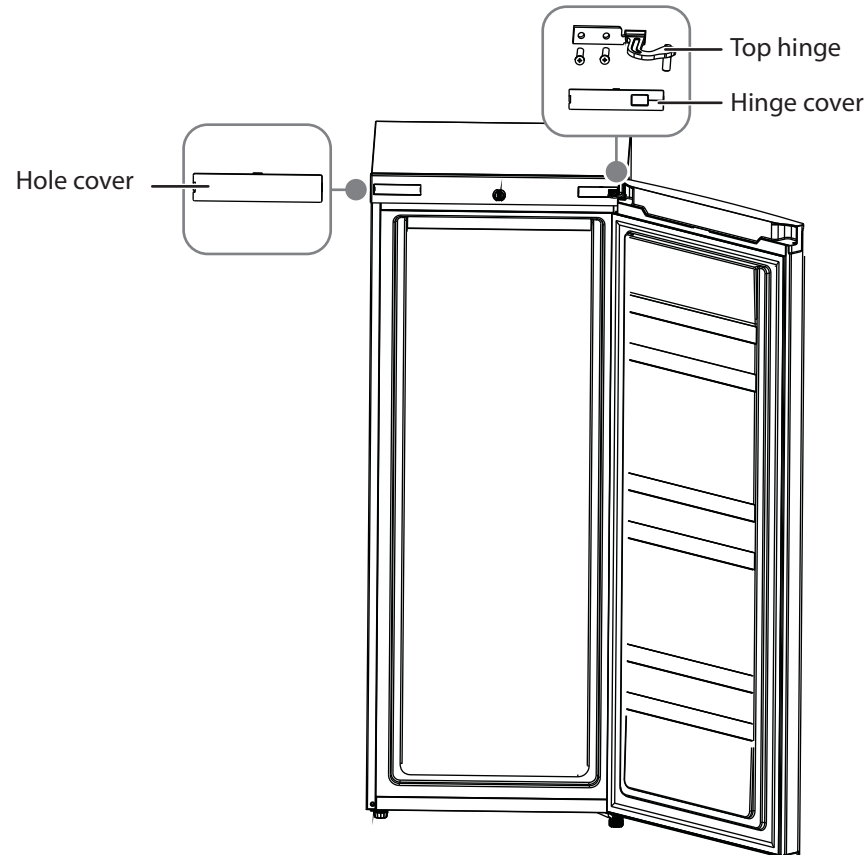



INSIGNIA™

5.3 Cu. Ft. Upright Freezer – White

- 3 While one person tilts your freezer backwards, remove the bottom hinge screws and hinge and the two leveling feet. Install the bottom hinge and leveling feet on the other side.

Tip

You can lay your freeze flat on the floor to make removing and installing the bottom hinge easier. If you do lay it flat, when you return it to the upright position, wait two hours before you plug it in.

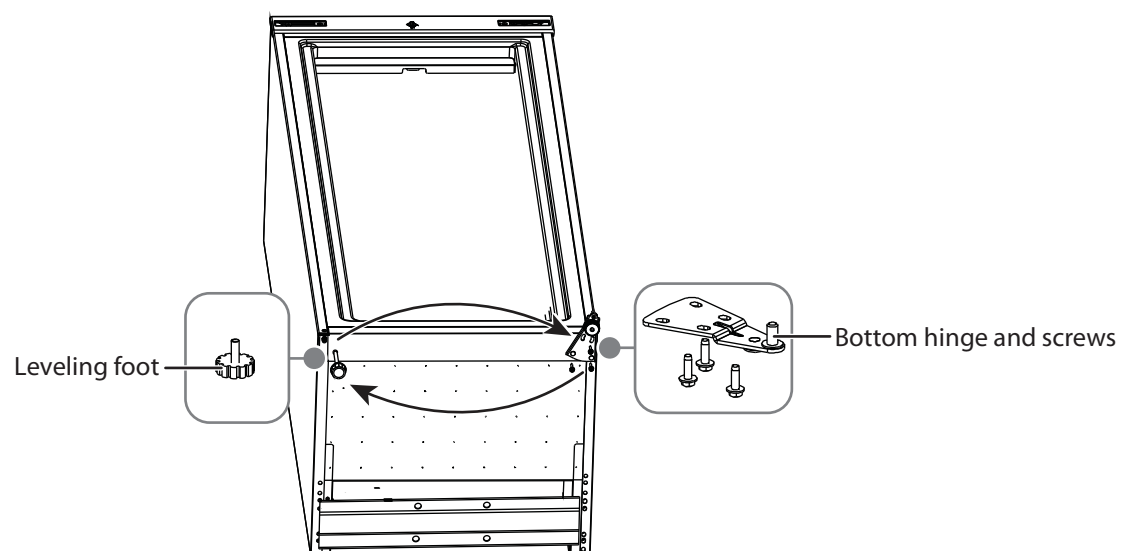

- 4 Remove the door stopper, then install it on the other side.

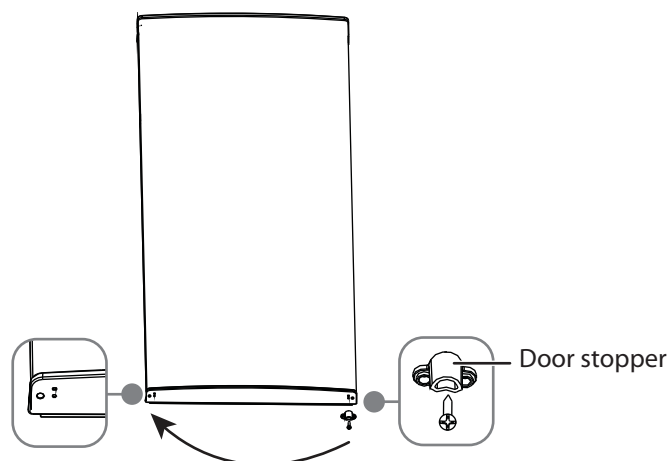

- 5 Align the door bottom so that the pin on the hinge slides into the hole in the door bottom.



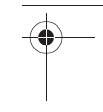
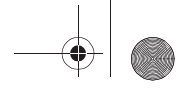

- 6** Align the hinge with the screw holes on the door and the hole in the top edge of the door. Slide the pin through the hole in the hinge and into the hole on the top edge of the door. Use the screws to attach the hinge to your freezer. Place the hole cover over the hinge opening on the other side of the door.

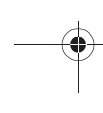
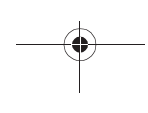
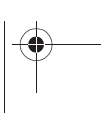
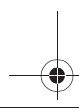
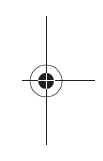
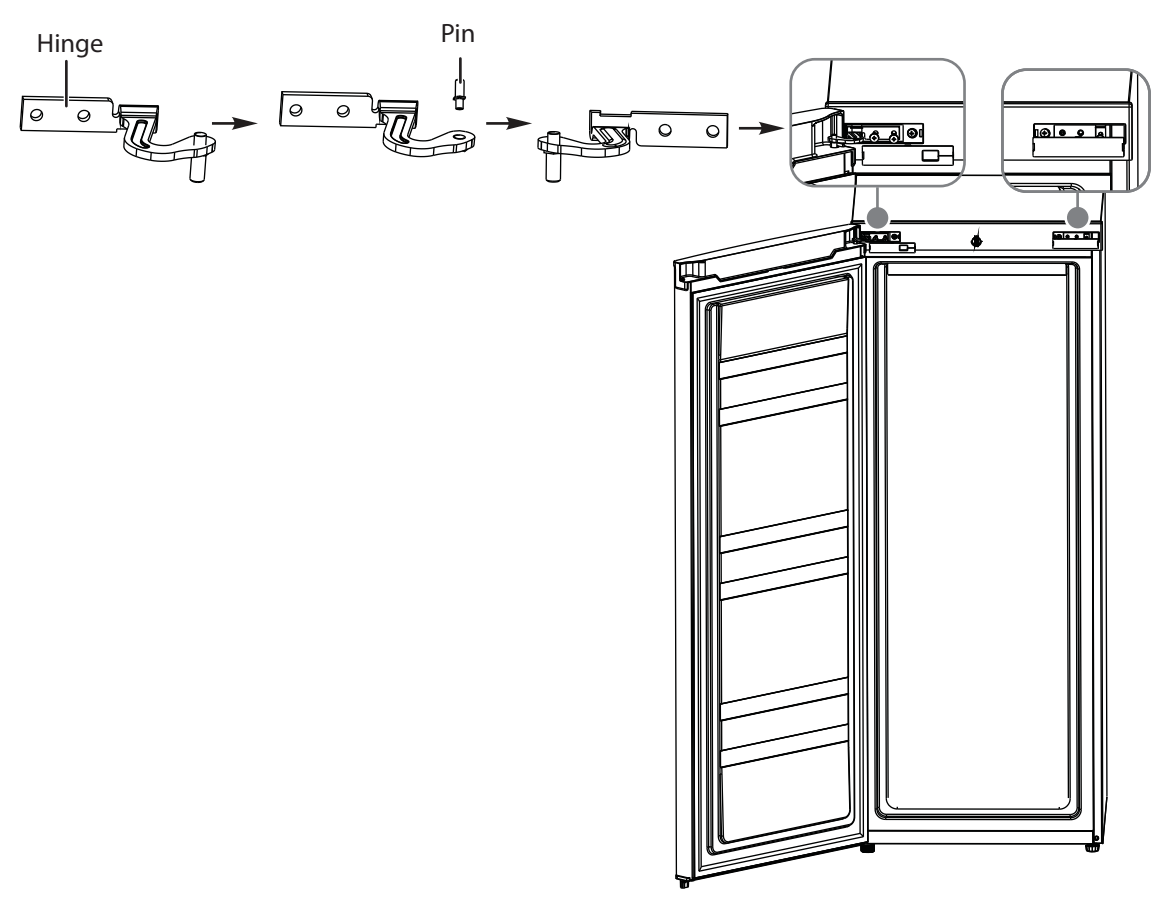

INSIGNIA™

5.3 Cu. Ft. Upright Freezer – White

Providing the correct power source

Check your local power source. Your freezer requires a 115V, 60Hz power supply.

Warnings

Make sure that:

- The power outlet accepts a 3-prong grounding plug. The third prong on the power cord plug grounds your freezer to minimize the possibility of electric shock. Do not modify the power plug.
- You do NOT plug anything else into the same power outlet as your freezer. You may overload the circuit which can cause a fire.
- You do NOT use an extension cord. If your freezer is too far from the power outlet, move your freezer or have an electrician install a plug closer to your freezer.
- The power outlet cannot be turned off with a switch or pull string.

Using a 3-prong plug and outlet

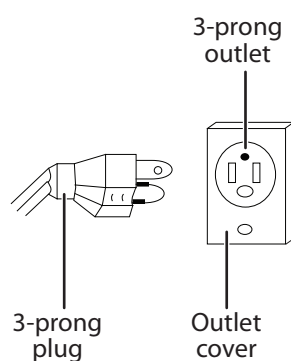

Using a grounding adapter

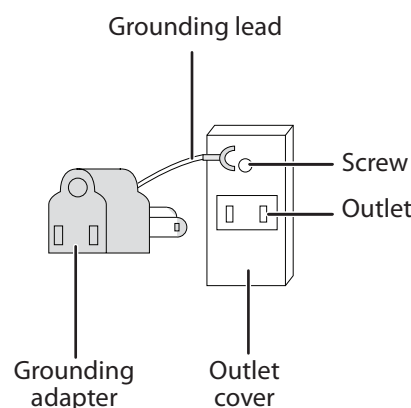

Using your freezer

The storage life of frozen foods varies. You should use the food before the recommended storage time expires. Place frozen food into your freezer as quickly as possible after purchase. If there are instructions on the packaging, carefully follow these instructions regarding storage times. Prepackaged, commercially-frozen food should be stored in accordance with the frozen food manufacturer's instructions for a three-star frozen food storage compartment or home freezer. Shelves are provided for the organization of odd-shaped items.

Note

If the power fails, food in your freezer will stay frozen for several hours, even in summer. During a power failure, do not open the door more than you have to and do not add new food.

- 1 Plug in your freezer. Wait for 30 minutes, then open the freezer door to determine if your freezer is working correctly. When your freezer is plugged into a power outlet, it runs continuously.
- 2 Wait two to four hours before putting food into your freezer. If the room temperature is high, wait four or more hours.
- 3 Turn the Control knob to adjust the temperature. Your freezer has three marked temperature settings:
 - MIN: 10.4°F ~ 5°F (-12°C ~ -15°C)
 - MID: -0.4°F ~ -4°F (-18°C ~ -20°C)
 - MAX: -7.6°F ~ -11.2°F (-22°C ~ -24°C)

You can set the temperature to one of the setting positions or to a setting position between the marked settings.

Notes

- You may need to adjust the temperature based on the ambient room temperature. If the room temperature is high, (for example, in summer) lower the freezer temperature. If the room temperature is low, (for example, in winter) raise the freezer temperature.
- You may need to adjust the temperature based on how much food is in your freezer.
- If your freezer is unplugged or loses power, you must wait three to five minutes before restarting it. Your freezer will not start if you attempt to restart it sooner.
- If the power fails, unplug your freezer, then wait until the power is back to normal before you plug it in.
- Large amounts of food lower the cooling efficiency of your freezer.
- Do not put bottled food or drinks in your freezer.

Cleaning your freezer

Your freezer is designed for year-round use with only minimal cleaning and maintenance. We recommend that you do the following every time you clean it to keep your freezer running odor-free and efficiently:

Caution

To prevent damage to the finish, do not use gasoline, benzine, thinner, or other solvents, and do not use abrasive cleaners.

- 1 Unplug your freezer from the power outlet.
- 2 Remove all food.
- 3 Wash the shelves with a mild detergent solution.
- 4 Wash the inside and outside with a cloth dampened with a non-corrosive, neutral detergent. If you use a detergent, remove the residual detergent with a cloth dampened with clear water. Do not use excessive detergent or water. Too much liquid may damage the electrical insulation.
- 5 Dry the inside and outside with a soft cloth or towel.
- 6 Make sure that you keep the door gasket (seal) clean so that the door seals tightly. This helps your freezer run efficiently.

Defrosting your freezer

Tip

To avoid standing water when you defrost, place some towels on the floor in front of your freezer.

- 1 Unplug your freezer.
- 2 Remove all food from your freezer, and place the food into containers that will prevent it from melting.
- 3 To speed the defrosting, you can:
 - Place a fan blowing on its highest speed right at the freezer. The ice will melt faster. After the ice melts, use towels to wipe up excess water, then use the fan to speed drying.
 - Place containers with hot water inside the freezer.
 - Use a plastic or wooden ice shovel (like a spatula) to remove thick layers of ice or frost. Do not use a sharp utensil (like a knife) because you may damage your freezer.
- 4 Use a cloth dampened with water or a mild cleaning solution to clean the inside of your freezer.
- 5 When you finish defrosting, wipe the inside with a dry towel.
- 6 Close your freezer, plug it into the power outlet, then put the food back into your freezer.

Storing your freezer

- 1 Unplug your freezer from the power outlet.
- 2 Remove all food.
- 3 Clean your freezer.
- 4 Take off the doors, and leave the shelves in place so that children may not easily climb inside.

Caution

Use extreme caution with children. Make sure that children cannot access your freezer.

Moving your freezer

- 1 Unplug your freezer from the power outlet.
- 2 Remove all food.
- 3 Securely tape down all loose items inside your freezer.
- 4 Tape the door shut.
- 5 Make sure that your freezer does not tilt more than 45° from the upright position during transportation.

Tips on saving energy

- Locate your freezer in the coolest area of the room, away from heat producing appliances or heating ducts and out of direct sunlight.
- Let hot foods cool to room temperature before placing them in your freezer. Overloading your freezer forces the compressor to run longer. Foods that freeze too slowly may lose quality or spoil.
- Wrap foods correctly and wipe containers dry before placing them in your freezer. This cuts down on frost build-up inside your freezer.

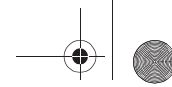

- Do not line the freezer storage shelves with aluminum foil, wax paper, or paper toweling. Liners interfere with cold air circulation and make your freezer less efficient.
- Organize and label food to reduce door openings and extended searches. Remove as many items as needed at one time, and close the door as soon as possible.

Troubleshooting

PROBLEM	SOLUTION
My freezer does not work.	<ul style="list-style-type: none"> • Make sure that your freezer is securely plugged into a working outlet. • Make sure that your power source has the correct voltage. Your freezer's voltage rate is on a label on the back of your freezer. • Check the house fuse or circuit breaker box and replace the fuse or reset the circuit breaker.
The freezer has a bad odor.	<ul style="list-style-type: none"> • Make sure that all food with a strong odor (like onions) is wrapped or stored in airtight packaging. • Certain containers and wrapping materials (such as paper, foil, or plastic) can cause odors. If you think this might be the case, try using different containers or a different brand of wrapping material. • Check for spoiled food and remove it. • Clean the inside of your freezer. See Cleaning your freezer on page 13.
The freezer door does not close completely.	<ul style="list-style-type: none"> • Make sure that no food packages are in the way. • Make sure that the door gasket (seal) is clean. See Cleaning your freezer on page 13. • If the door gasket does not seal, try heating then cooling the seal. You can use an electric hair dryer to heat the seal. • Make sure that your freezer is level. See Leveling your freezer on page 8.
The freezer door is hard to open.	<ul style="list-style-type: none"> • When you open the freezer door, warm air rushes inside. When you close the door, the warm air rushes to the condenser which causes a vacuum. This causes the door to be hard to open for about 10 to 15 seconds after closing. • If the door is hard to open at other times, try rubbing paraffin wax or petroleum jelly along the edges of the entire gasket. Paraffin wax is used for canning and is safe for use around food.
The compressor runs for a long time or turns on and off frequently.	<p>The compressor runs longer if:</p> <ul style="list-style-type: none"> • The room temperature is high. • You just added a large amount of food. Wait for the food to freeze, then check again. • You open and close the door frequently. • The door gasket is dirty. Clean the gasket. See Cleaning your freezer on page 13. • Your freezer has been disconnected for a period of time. Wait for your freezer to cool (about four hours) before adding food. • You have the temperature set too low. Set the Control knob to a higher temperature.
The light inside the freezer does not turn on.	<ul style="list-style-type: none"> • Make sure that your freezer is plugged into a working outlet. • Check to see if the light is damaged. If the light is damaged, have it replaced by a qualified service technician.
The freezer makes unusual noises or vibrations.	<ul style="list-style-type: none"> • Metal parts expand and contract as the temperature changes. This is normal. • When the refrigerant is circulating throughout the system, your freezer may make noises. This is normal. • Remove items from the top of your freezer. • Make sure that your freezer is level. See Leveling your freezer on page 8. • If your freezer is touching walls, move it away from the walls. • Make sure that the shelves are installed correctly.
The water pan overflows.	<ul style="list-style-type: none"> • You have too much food in your freezer or stored food contains too much water which results in heavy defrosting. • The doors are not closed correctly, resulting in increased defrosting.

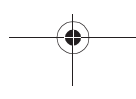
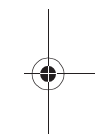
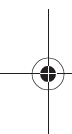



PROBLEM	SOLUTION
The outside of the freezer is hot.	Heat dissipation from the condenser may make the outside feel hot. This is normal and happens if: <ul style="list-style-type: none"> • The room temperature is high. • You have too much food in your freezer. • You open and close the door excessively.
Water condenses on the outside of the freezer.	<ul style="list-style-type: none"> • Condensation on the exterior surface and door seal is normal when the room humidity is high. • When you open the door, warm, moist outside air meets the cold dry air inside your freezer. These are normal. Just wipe off the condensation with a clean towel.

Specifications

Dimensions (W × D × H)	21.7 × 21.7 × 55.9 in. (55 × 55 × 142 cm)
Weight	Gross Weight: 88.2 lbs (40 kg) Net Weight: 79.4 lbs (36 kg)
Power requirements	115V ~ 60Hz
Power cord length	5.4 ft. (1.65 m)
Average life expectancy	8 years
Temperature control knob	MIN: 10.4°F ~ 5°F (-12°C ~ -15°C) MID: -0.4°F ~ -4°F (-18°C ~ -20°C) MAX: -7.6°F ~ -11.2°F (-22°C ~ -24°C) Note: Temperatures may vary slightly.



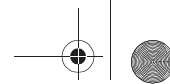

INSIGNIA™

5.3 Cu. Ft. Upright Freezer – White

ONE-YEAR LIMITED WARRANTY

Definitions:

The Distributor* of Insignia branded products warrants to you, the original purchaser of this new Insignia-branded product ("Product"), that the Product shall be free of defects in the original manufacturer of the material or workmanship for a period of one (1) year from the date of your purchase of the Product ("Warranty Period").

For this warranty to apply, your Product must be purchased in the United States or Canada from a Best Buy branded retail store or online at www.bestbuy.com or www.bestbuy.ca, and is packaged with this warranty statement.

How long does the coverage last?

The Warranty Period lasts for 1 year (365 days) from the date you purchased the Product. Your purchase date is printed on the receipt you received with the Product.

What does this warranty cover?

During the Warranty Period, if the original manufacture of the material or workmanship of the Product is determined to be defective by an authorized Insignia repair center or store personnel, Insignia will (at its sole option): (1) repair the Product with new or rebuilt parts; or (2) replace the Product at no charge with new or rebuilt comparable products or parts. Products and parts replaced under this warranty become the property of Insignia and are not returned to you. If service of Products or parts are required after the Warranty Period expires, you must pay all labor and parts charges. This warranty lasts as long as you own your Insignia Product during the Warranty Period. Warranty coverage terminates if you sell or otherwise transfer the Product.

How to obtain warranty service?

If you purchased the Product at a Best Buy retail store location, please take your original receipt and the Product to any Best Buy store. Make sure that you place the Product in its original packaging or packaging that provides the same amount of protection as the original packaging. If you purchased the Product from a Best Buy online web site (www.bestbuy.com or www.bestbuy.ca), mail your original receipt and the Product to the address listed on the web site. Make sure that you put the Product in its original packaging or packaging that provides the same amount of protection as the original packaging.

To obtain warranty service, in the United States call 1-888-BESTBUY, Canada call 1-866-BESTBUY. Call agents may diagnose and correct the issue over the phone.

Where is the warranty valid?

This warranty is valid only in the United States and Canada at Best Buy branded retail stores or websites to the original purchaser of the product in the county where the original purchase was made.

What does the warranty not cover?

This warranty does not cover:

- Food loss/spoilage due to failure of refrigerator or freezer
- Customer instruction/education
- Installation
- Set up adjustments
- Cosmetic damage
- Damage due to weather, lightning, and other acts of God, such as power surges
- Accidental damage
- Misuse
- Abuse
- Negligence
- Commercial purposes/use, including but not limited to use in a place of business or in communal areas of a multiple dwelling condominium or apartment complex, or otherwise used in a place of other than a private home.
- Modification of any part of the Product, including the antenna
- Display panel damaged by static (non-moving) images applied for lengthy periods (burn-in).
- Damage due to incorrect operation or maintenance
- Connection to an incorrect voltage or power supply
- Attempted repair by any person not authorized by Insignia to service the Product
- Products sold "as is" or "with all faults"
- Consumables, including but not limited to batteries (i.e. AA, AAA, C etc.)
- Products where the factory applied serial number has been altered or removed
- Loss or Theft of this product or any part of the product
- Display panels containing up to three (3) pixel failures (dots that are dark or incorrectly illuminated) grouped in an area smaller than one tenth (1/10) of the display size or up to five (5) pixel failures throughout the display. (Pixel based displays may contain a limited number of pixels that may not function normally.)
- Failures or Damage caused by any contact including but not limited to liquids, gels or pastes.

REPAIR REPLACEMENT AS PROVIDED UNDER THIS WARRANTY IS YOUR EXCLUSIVE REMEDY FOR BREACH OF WARRANTY. INSIGNIA SHALL NOT BE LIABLE FOR ANY INCIDENTAL OR CONSEQUENTIAL DAMAGES FOR THE BREACH OF ANY EXPRESS OR IMPLIED WARRANTY ON THIS PRODUCT, INCLUDING, BUT NOT LIMITED TO, LOST DATA, LOSS OF USE OF YOUR PRODUCT, LOST BUSINESS OR LOST PROFITS. INSIGNIA PRODUCTS MAKES NO OTHER EXPRESS WARRANTIES WITH RESPECT TO THE PRODUCT, ALL EXPRESS AND IMPLIED WARRANTIES FOR THE PRODUCT, INCLUDING, BUT NOT LIMITED TO, ANY IMPLIED WARRANTIES OF AND CONDITIONS OF MERCHANTABILITY AND FITNESS FOR A PARTICULAR PURPOSE, ARE LIMITED IN DURATION TO THE WARRANTY PERIOD SET FORTH ABOVE AND NO WARRANTIES, WHETHER EXPRESS OR IMPLIED, WILL APPLY AFTER THE WARRANTY PERIOD. SOME STATES, PROVINCES AND JURISDICTIONS DO NOT ALLOW LIMITATIONS ON HOW LONG AN IMPLIED WARRANTY LASTS, SO THE ABOVE LIMITATION MAY NOT APPLY TO YOU. THIS WARRANTY GIVES YOU SPECIFIC LEGAL RIGHTS, AND YOU MAY ALSO HAVE OTHER RIGHTS, WHICH VARY FROM STATE TO STATE OR PROVINCE TO PROVINCE.

Contact Insignia:

For customer service please call 1-877-467-4289

www.insigniaproducts.com

INSIGNIA is a trademark of Best Buy and its affiliated companies.

Distributed by Best Buy Purchasing, LLC

7601 Penn Ave South, Richfield, MN 55423 U.S.A.

©2017 Best Buy. All rights reserved.

Made in China

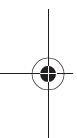

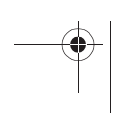
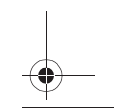
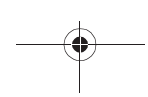
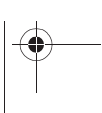
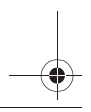
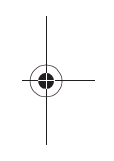
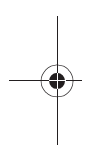
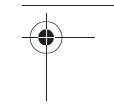
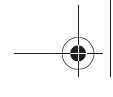

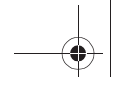

INSIGNIA™

5.3 Cu. Ft. Upright Freezer – White

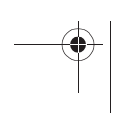
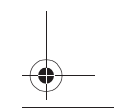
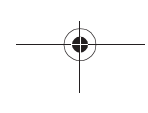
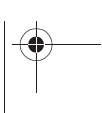
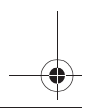
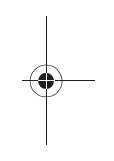
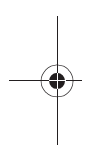
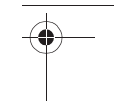

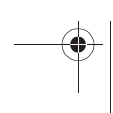
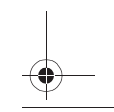
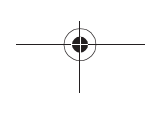
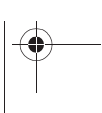
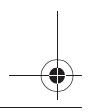
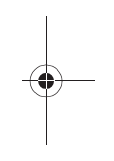
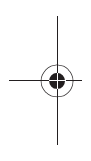
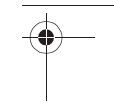
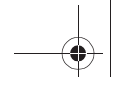

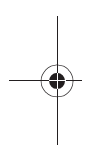
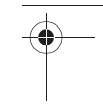
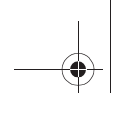

INSIGNIA™

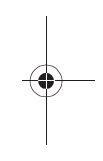

**For product inquiries, please contact us with the information below:
1-877-467-4289**

www.insigniaproducts.com

INSIGNIA is a trademark of Best Buy and its affiliated companies.

Distributed by Best Buy Purchasing, LLC

7601 Penn Ave South, Richfield, MN 55423 U.S.A.

©2017 Best Buy. All rights reserved.

Made in China

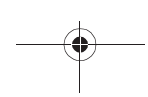
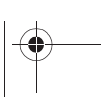
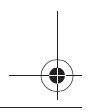

V2 ENGLISH
17-0865

