

PRODUCT & CUTOUT DIMENSIONS DIMENSIONS DU PRODUIT ET DES DÉCOUPES

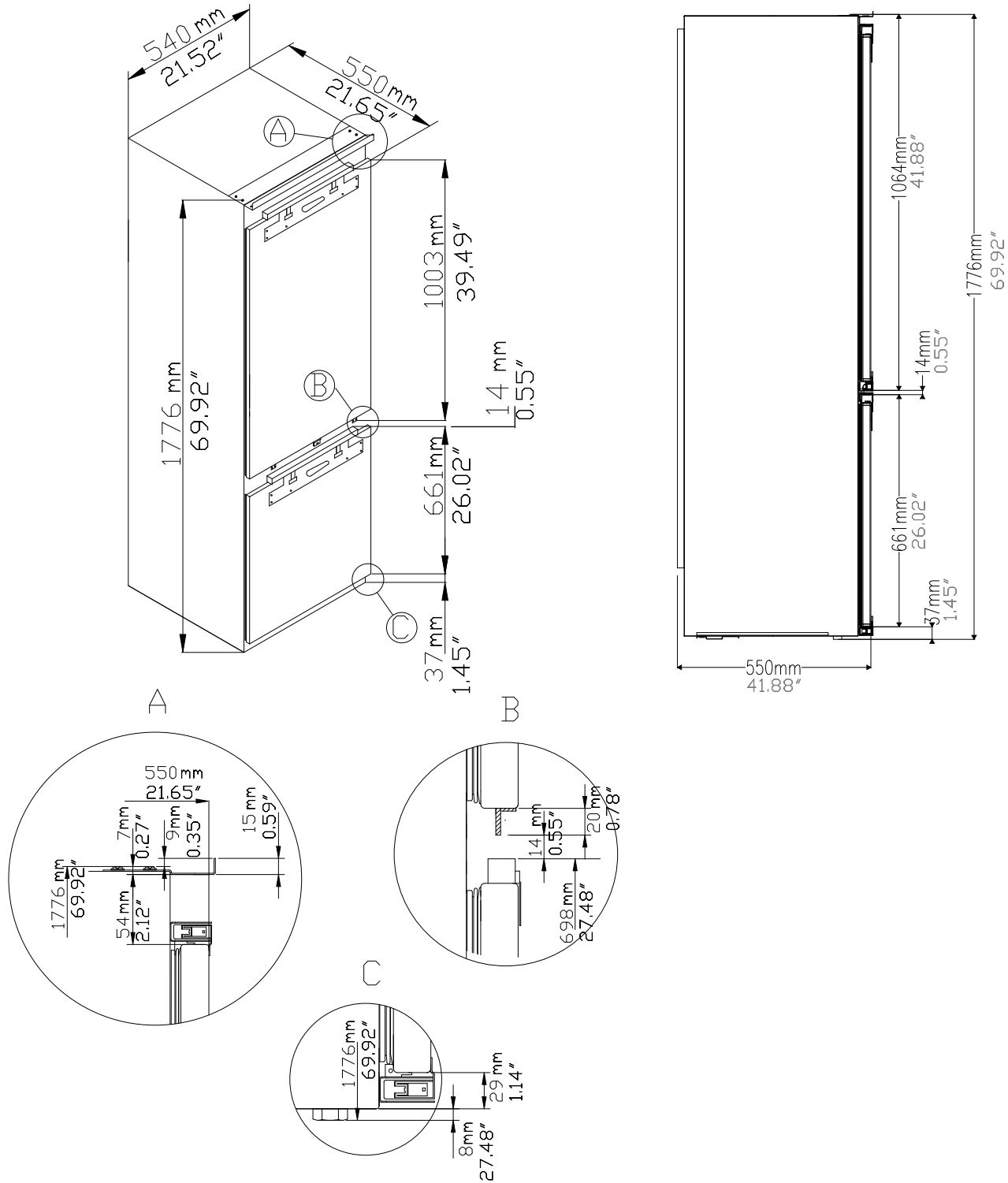

Model/Modèle: FFRBI1704-21

PRODUCT DIMENSIONS - DIMENSIONS DU PRODUIT



PRODUCT & CUTOUT DIMENSIONS DIMENSIONS DU PRODUIT ET DES DÉCOUPES



Model/Modèle: FFRBI1704-21

PRODUCT DIMENSIONS - DIMENSIONS DU PROUIT

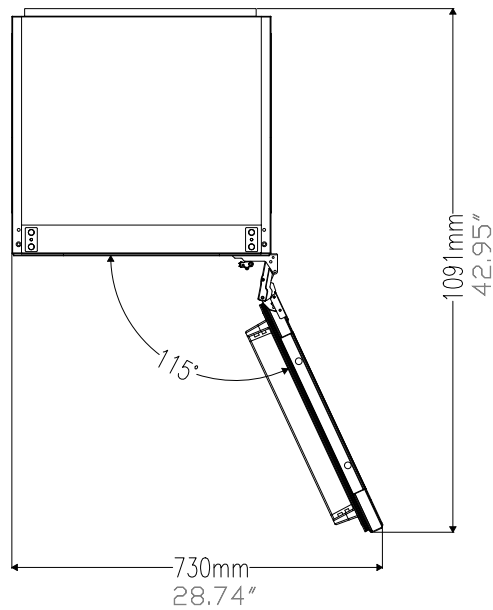
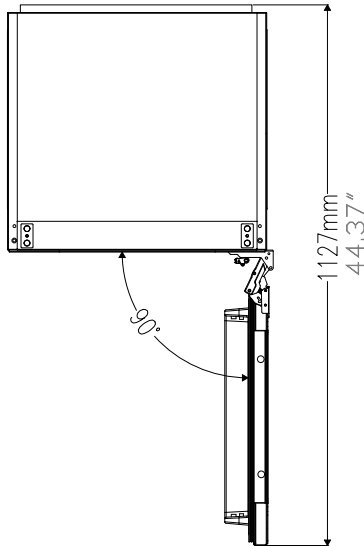

CUTOUT DIMENSIONS - DIMENSIONS DES DÉCOUPES

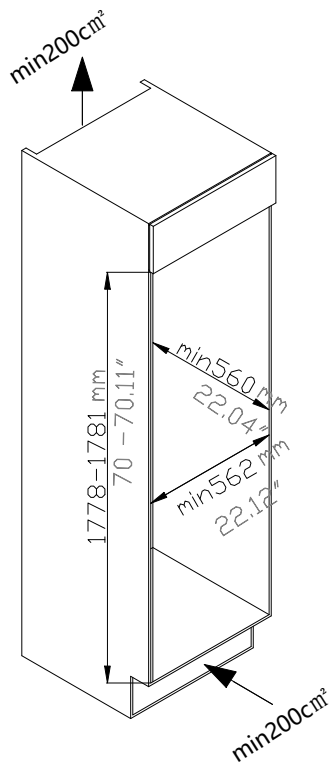

An air intake should be provided somewhere in the cabinet run to allow free air in. In this example, a plinth vent is shown underneath the refrigerator.

A cutout should be made in the plinth below the fridge/freezer and this finished neatly using the air vent grille.

Alternatively, a thin section of the plinth can be removed to allow air into the unit (recommended 600mm x 10mm)

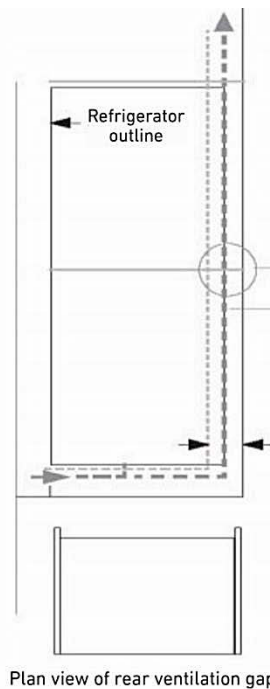

The top of the cabinet needs to be vented into the room.

Recommended size of vent opening: 500 x 30mm.
19.68 x 1.18"

If the furniture does not allow free air into the room then a plinth vent, or other means of ventilation needs to be provided to ensure a natural flow of air.

min. 30 mm / 1.18"

There should be space at the rear of the cabinet to allow cool air to be drawn over the condenser.

Recommended: 500 x 35mm
19.68 x 1.37"