

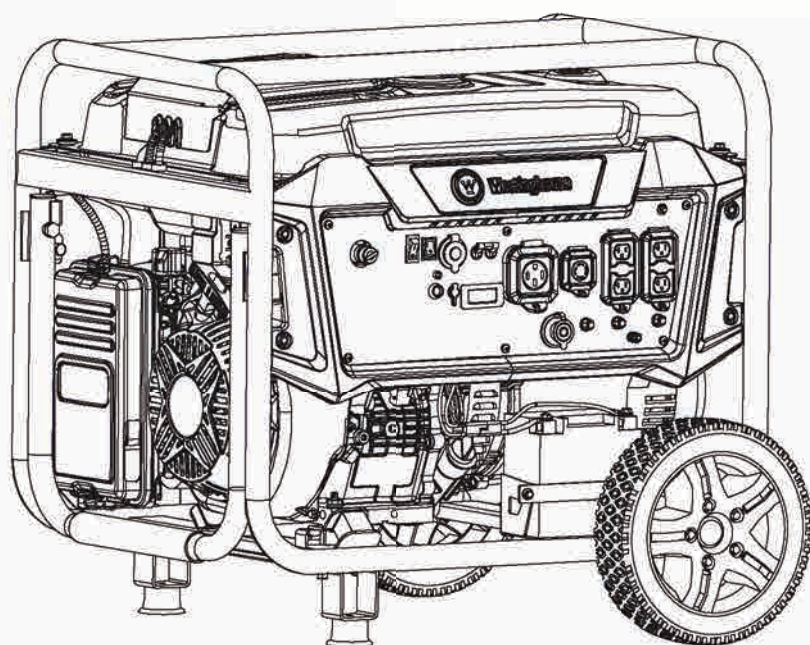

User Manual

WGen9500DFc EFI
Portable Generator



DO NOT RETURN THIS PRODUCT TO THE STORE

If you have questions or need assistance, please call customer service at 855-944-3571.

TABLE OF CONTENTS

Introduction	2-3
Safety	4-11
Electrical	12
Components.....	13-14
Assembly	15-17
Operation	18-26
Maintenance.....	27-33
Troubleshooting.....	34
Schematics	35
Service hotline/Company address	Back Page

INTRODUCTION

⚠ WARNING Operating, servicing, and maintaining this equipment can expose you to chemicals including engine exhaust, carbon monoxide, phthalates, and lead, which are known to the State of California to cause cancer and birth defects or other reproductive harm. To minimize exposure, avoid breathing exhaust, and wear gloves or wash your hands frequently when servicing this equipment. For more information go to www.P65warnings.ca.gov.

DISCLAIMERS

All information, illustrations, and specifications in this manual were in effect at the time of publishing. The illustrations used in this manual are intended as representative reference views only. We reserve the right to make any specification or design change without notice.

ALL RIGHTS RESERVED

All rights reserved. No reproduction allowed in any form without written permission from Westinghouse Outdoor Power Equipment.



⚠ DANGER Read this manual before using or performing maintenance on this product. Failure to follow the instructions and safety precautions in this manual can result in serious injury or death.

UPDATES

The latest User Manual for Westinghouse products can be found under our support tab: westinghouse.com/pages/manuals or scan the following QR code with a smartphone camera to be directed to the link.



PRODUCT REGISTRATION

For trouble-free warranty coverage, it is important to register the Westinghouse product.

Register by:

- Completing and mailing the product registration card included in the carton.
- Going online at: westinghouse.com/register
- Scanning the following QR code with a smartphone camera to be directed to the mobile registration link.



For Your Records

Date of Purchase: _____

Model Number: _____

Serial Number: _____

Place of Purchase: _____

- Sending the following product information to:

Westinghouse Outdoor Power

Warranty registration
777 Manor Park Drive
Columbus, OH 43228

IMPORTANT: Keep the purchase receipt for trouble-free warranty coverage.

INTRODUCTION

SPECIFICATIONS

AC Voltage	120 V / 240 V
Power (Running).....	9500 W (Gasoline), 8500 W (Propane),
Power (Peak)	12500 W (Gasoline), 11200 W (Propane),
AC Current	40 A (Gasoline), 35 A (Propane),
Frequency	60 Hz
Phase	Single
RPM.....	3600
Power Factor.....	1.0
Insulation Class.....	H
Maximum Ambient Temperature.....	104°F (40°C)
Fuel Type.....	Unleaded gasoline (87–93 Octane) Do not use E15 or E85 fuel in this product.
Fuel Capacity.....	6.6 gallons (25 liters)
Oil Capacity.....	1.16 quarts (1.1 liters)
Oil Type.....	SAE 10W-30
Spark Plug	F7RTC
Spark Plug Gap	0.028–0.032 in. (0.70–0.80 mm)
Valve Intake Clearance	0.0031 – 0.0047 in. (0.08 – 0.12 mm)
Valve Exhaust Clearance	0.0051 – 0.0067 in. (0.13 – 0.17 mm)
AC Grounding System.....	Bonded to frame

NOTICE

This product is designed and rated for continuous operation at ambient temperatures between 23°F (–5°C) and 104°F (40°C). If needed, this product can be operated in extremely hot or extremely cold temperatures for short periods. If the product is exposed to extreme temperatures during storage, it should be brought back within the optimal temperature range before operation. This product must always be operated outdoors in a well-ventilated area and far away from doors, windows, and other vents.

Maximum wattage and current are subject to and limited by such factors as fuel BTU content, ambient temperature, altitude, engine conditions, etc. Maximum power decreases about 3.5% for each 1,000 feet above sea level, and will also decrease about 1% for each 10°F (6°C) above 60°F (16°C) ambient temperature.

NOTICE

The ECU can monitor the intake pressure and intake temperature in real time. Through speed density control (type D), the fuel injection pulse width is controlled to ensure the power of the plateau working conditions without replacing high-altitude accessories.

HAVE QUESTIONS?
Email us at service@wpowereq.com
or call 1-855-944-3571

SAFETY

SAFETY DEFINITIONS

The words DANGER, WARNING, CAUTION, and NOTICE are used throughout this manual to highlight important information. Be sure that the meanings of this safety information are known to all who operate, perform maintenance on, or are near the generator.



This safety alert symbol appears with most safety statements. It means attention, become alert, safety is involved! Please read and abide by the message that follows the safety alerts symbol.

DANGER

Indicates a hazardous situation which, if not avoided, will result in death or serious injury.

WARNING

Indicates a hazardous situation which, if not avoided, could result in death or serious injury.

CAUTION

Indicates a hazardous situation which, if not avoided, could result in minor or moderate injury.











NOTICE

Indicates a situation which can cause damage to the generator, personal property, and/or the environment, or cause the equipment to operate improperly.

NOTE: Indicates a procedure, practice or condition that should be followed for the generator to function in the manner intended.

SAFETY SYMBOLS

Follow all safety information contained in this user manual as well as the information on the product labeling.

SYMBOL	DESCRIPTION
	Safety Alert Symbol
	Fire Hazard
	Electrical Shock Hazard
	Burn Hazard. Do not touch hot surfaces.
	Asphyxiation Hazard
	Do Not Operate in Wet Conditions
	Read Manufacturer's Instructions
	Maintain Safe Distance
	Ground. Consult with electrician to determine grounding requirements before operation.
	Carbon Monoxide

SAFETY

IMPORTANT SAFETY INSTRUCTIONS

⚠ DANGER Generator exhaust contains high levels of carbon monoxide (CO), an invisible, odorless, and extremely poisonous gas. If you smell exhaust fumes, you are breathing carbon monoxide. But, even if you do not smell exhaust fumes, you may be inhaling CO.

ONLY operate generators outside, in a well-ventilated area. NEVER operate generators indoors, doing so CAN KILL YOU IN MINUTES.

- **Correct Use** – Only use generators outside and downwind, far away from windows, doors and vents. Always direct exhaust away from occupied spaces. Always install battery-powered carbon monoxide detectors or plug-in carbon monoxide detectors with battery back-up in living areas. See Figure 1.
- **Incorrect Use** – NEVER use a generator in a house, garage, basement, attic, crawl space or any other fully or partially enclosed area. Areas such as these can allow dangerous levels of carbon monoxide to accumulate. An open door or a running fan WILL NOT provide adequate ventilation. See Figure 2.

If feeling dizzy, weak, or sick while using the generator, move to fresh air immediately. Contact a doctor. This may be carbon monoxide poisoning.

⚠ DANGER Fire and electrocution hazard. **DO NOT** connect to a building's electrical system unless the generator and a transfer switch have been properly installed and the electrical output has been verified by a qualified electrician. The connection must isolate the generator power from utility power and must comply with all applicable laws and electrical codes. Failure to properly isolate the generator power could cause property damage and create a dangerous backfeed of electricity which could kill or seriously injure utility workers.

⚠ DANGER Electrocutation hazard. **NEVER** use the generator in a location that is wet or damp. **NEVER** expose the generator to rain, snow, water spray, or standing water while in use. Protect the generator from all hazardous weather conditions. Moisture or ice can cause a short circuit or other malfunction in the electrical circuit.

⚠ WARNING Become familiar with all the instructions, safety warnings, illustrations, and specifications provided with this product. Failure to follow the manufacturer's instructions may result in electric shock, fire, and/or carbon monoxide poisoning that can lead to death or serious injury.

NOTICE Install battery-powered carbon monoxide detectors or plug-in carbon monoxide detectors with battery back-up in living areas.

- This product should ONLY be used outdoors.

FIG. 1

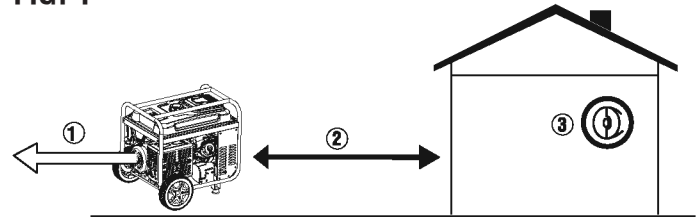

- 1 - Exhaust (CO)
- 2 - Only use OUTSIDE and FAR AWAY from windows, doors, and vents
- 3 - CO detectors in living areas

FIG. 2

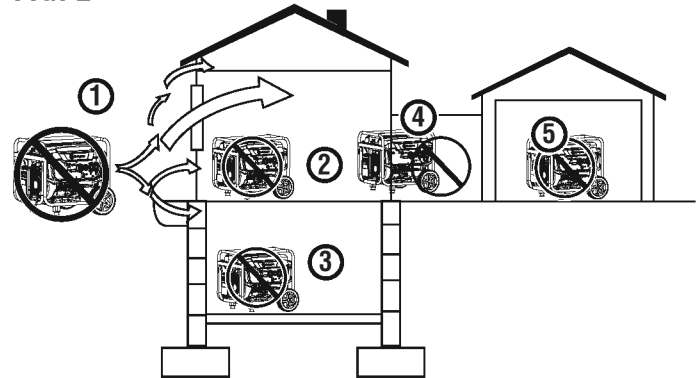

- 1 - Exhaust (CO)
- 2 - Living area
- 3 - Basement / crawlspace
- 4 - Entryway / porch / mudroom
- 5 - Garage

- NEVER use a generator in a house, garage, basement, attic, crawl space or any other fully or partially enclosed area. Areas such as these can allow dangerous levels of carbon monoxide to accumulate. Carbon monoxide (CO), an invisible, odorless, and extremely poisonous gas CAN KILL YOU IN MINUTES.
- Only use OUTSIDE and far away from windows, doors, and vents as recommended by the US Department of Health and Human Services Centers for Disease Control and Prevention. Specific houses and/or wind conditions may require additional distance.
- The National Electrical Code requires the use of a transfer switch or other suitable transfer equipment whenever a portable generator is connected to a building's electrical system. Transfer switches isolate generator power from utility power and prevent backfeeding of electric power into the utility system.

NOTE: A transfer switch must be installed by a qualified electrician in accordance with applicable electrical codes. Some jurisdictions may require the installation to be inspected by local authorities. Keep all relevant installation, inspection, and maintenance information.

- Never use the generator to power medical support equipment.
- Never expose the generator to rain, snow, water spray, or standing water while in use. Store and operate the unit in a dry or covered (but not enclosed) location.
- Do not let children or untrained individuals operate the generator.
- Keep children, bystanders, and pets a minimum of 10 ft. away from a running generator.

SAFETY

- Maintain Safe Distance. While operating and storing, keep at least five feet of clearance on all sides of the generator, including overhead. Turn the unit off and allow it to cool a minimum of 30 minutes before storage. Heat created by the muffler and exhaust gases could be hot enough to cause serious burns and/or ignite combustible objects.
- Do not operate the unit in areas where combustible or hazardous materials are stored including gasoline filling stations.
- Do not operate the generator while barefoot, with wet hands or feet, while standing in water or in wet conditions.
- Do not use this unit when tired or under the influence of drugs, alcohol, or medication.
- Burn Hazard. Do not touch hot surfaces.
- Do not contact the muffler or engine. They are very HOT and will cause severe burns. Do not put body parts or any flammable or combustible materials in the direct path of the exhaust.
- Keep hands, fingers, feet, and other body parts away from all moving parts of the generator.
- Do not connect worn or damaged electrical cords to the generator. NEVER touch frayed or exposed wires.
- Do not operate the generator on an incline. The unit should always be placed on a flat stable surface.
- Inspect the physical condition of the product prior to each use. Look for loose bolts, fluid leaks, and other signs of wear. Replace all damaged items. For replacement parts or assistance, contact our customer service team.
- For optimal performance, operate the generator in temperatures between 23°F (-5°C) and 104°F (40°C) with a maximum relative humidity of 90%.
- Before starting the generator, inspect all fluids (oil and gasoline).
- Do not remove the oil dipstick or fuel cap when the generator is running.
- Securely tighten the oil dipstick after adding oil and the fuel cap after adding gasoline.
- Avoid skin contact with engine oil or gasoline. Wear protective clothing and equipment. Wash all exposed skin with soap and water. Prolonged skin contact with gasoline or engine oil may cause severe skin irritation and other adverse reactions.
- Generators vibrate and bounce during normal operation. Inspect the generator and all of the cords connected to it for any damage that may have resulted from the vibration. Replace or repair damaged items as needed. Do not use the generator or any items that show signs of damage.
- All electrical tools and appliances operated from this generator must be properly grounded by use of a third wire or be double-insulated.
- Before transporting the generator, disconnect the spark plug boot, drain the fuel tank and properly restrain the unit.
- Fuel or oil may leak from the generator during transport. Place a towel, plastic sheet, or absorbent pad beneath the unit to protect the transportation vehicle.
- To prolong the life of this product, follow the instructions in the *Maintenance* section of this manual.
- Replace damaged or worn items with recommended or equivalent replacement parts. Using an incorrect or incompatible part might create a hazard that could result in serious personal injury.

- Always remove any tools or other service equipment used during maintenance away from the generator before operating.

GROUNDING

See Figure 3.

 **WARNING** Shock hazard. Failure to properly ground the generator can result in electric shock.

 **NOTICE** Only use grounded 3-prong extension cords, tools, and appliances, or double-insulated tools and appliances.

The generator neutral is bonded to the frame. There is a permanent conductor between the generator (stator wire) and the frame. If this generator will be used only with cord and plug equipment connected to the receptacles mounted on the generator, National Electric Code does not require that the unit be grounded. However, other methods of using the generator may require grounding to reduce the risk of shock or electrocution.

Before using the ground terminal, consult a qualified electrician, electrical inspector, or local agency having jurisdiction for local codes or ordinances that apply to the intended use of the generator.

DISCONNECTING THE BONDED NEUTRAL

See Figure 3.

The bonded neutral should only be removed under specific circumstances. Consult a qualified electrician to determine if circumstances require disconnecting the bonded neutral.

- Remove the alternator cover.
- Remove the green/yellow bonded jumper wire from the ground bolt and unmarked terminal connection. Reinstall the bolts and tighten securely.
- Keep the bonded jumper wire in a secure location so that the generator can be returned to the original configuration.

 **NOTICE** Apply a new “NEUTRAL UNBONDED” Label over the “NEUTRAL BONDED TO FRAME” label on the front of the control panel.

SAFETY PRECAUTIONS FOR GASOLINE AND GASOLINE VAPOR

 **DANGER** Fire and explosion hazard. Gasoline is highly explosive and flammable and can cause severe burns or death.

 **WARNING** Fire and Burn Hazard. NEVER loosen or remove the fuel cap while the generator is running. Turn the unit off and allow it to cool for at least five minutes before adding gasoline. Loosen the fuel cap slowly.

SAFETY

⚠ WARNING In case of a gasoline fire, do not attempt to extinguish the flame unless the engine/fuel control switch is in the OFF position. Introducing an extinguisher to a generator with an open fuel valve could create an explosion hazard.

- Fire Hazard. Gasoline is highly flammable. Handle with care.
- Never use gasoline as a cleaning agent.
- Gasoline is a skin irritant and needs to be cleaned up immediately if it comes in contact with the skin.
- Do not store gasoline near furnaces, water heaters, or any other appliances that produce heat or have automatic ignitions.
- Keep gasoline away from sparks, open flames, pilot lights, heat, and other sources of ignition.
- Store any containers containing gasoline in a well-ventilated area, away from any combustibles or source of ignition.
- ALWAYS store gasoline in a container approved for gasoline. Unapproved containers can break or deteriorate allowing gasoline or gasoline vapors to escape which can create a serious hazard.
- Gasoline has a distinctive odor, this will help detect potential leaks quickly.
- Gas vapors can cause a fire if ignited.
- Do not smoke when handling fuel, adding fuel to the generator, or emptying the gas tank.
- Wear eye protection while refueling.
- Before adding fuel to the generator, turn the unit off and allow it to cool a minimum of five minutes. If necessary, move the unit to level ground.
- Do not remove the fuel tank cap when the generator is running.
- Loosen the fuel cap slowly to safely release pressure, keep gasoline from escaping around the cap, and to avoid the heat from the muffler igniting fuel vapors.
- NEVER fill the gasoline tank beyond the maximum fill ring on the fuel screen. Keeping gasoline levels at or below the fill ring will allow for fuel expansion. Overfilling the fuel tank can result in a sudden overflow of gasoline and result in spilled gasoline coming in contact with HOT surfaces.
- Spilled fuel can ignite. Clean spills immediately and allow area to dry before operating the generator. NEVER attempt to burn off spilled fuel.
- Securely tighten the fuel cap after adding gasoline.
- Do not cover the fuel cap while the generator is in operation. Covering the cap may cause the engine to fail or damage the product.
- Drain fuel before storing the unit. Store the unit and the fuel separately in well-ventilated areas away from sparks, open flames, pilot lights, heat, and other sources of ignition.
- Turn the unit off and allow it to cool a minimum of 30 minutes before draining fuel.

FIG. 3

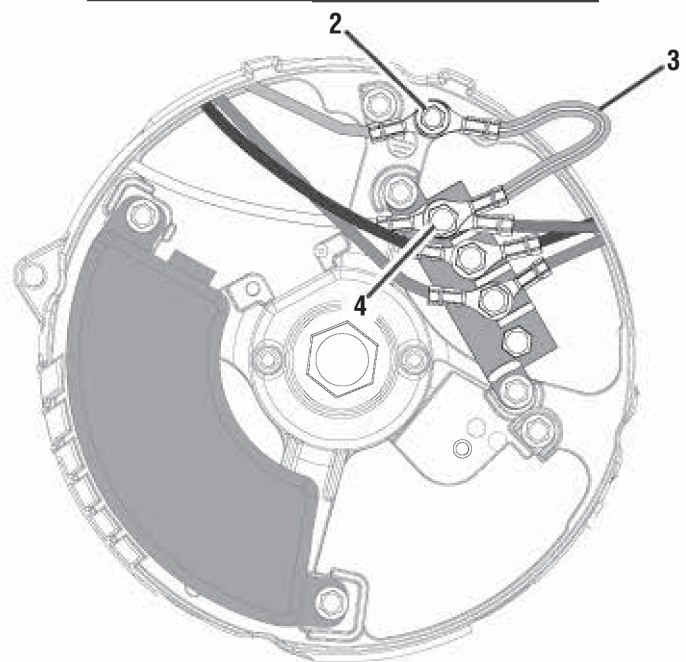
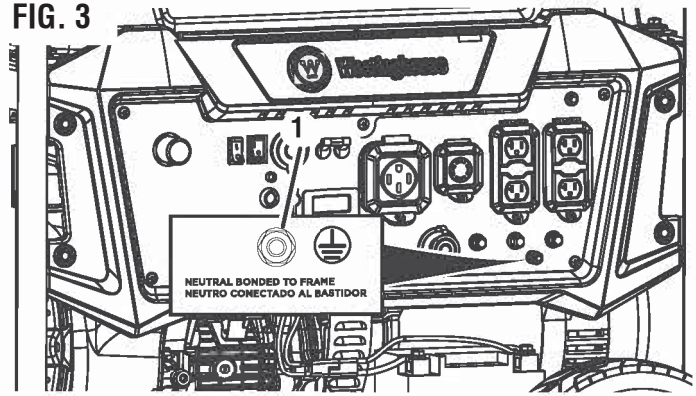

- 1 - Ground terminal
- 2 - Ground bolt
- 3 - Bonded jumper wire (green / yellow)
- 4 - Unmarked terminal connection

SAFETY

LIQUID PETROLEUM GAS (LPG/PROPANE)

⚠ WARNING Fire and explosion hazard. Never use a gas container, LPG/propane hose, propane cylinder or any other fuel item that appears to be damaged. If there is a strong smell of propane while operating the generator, fully close the propane cylinder valve immediately. Once the propane is off, use soapy water to inspect for leaks on the hose and connections on the tank valve and the generator. Do not smoke or light a cigarette or inspect for leaks using any open flame source such as a match or lighter. If a leak is found, contact a qualified technician to inspect and repair the LPG/propane system before using the generator.

⚠ CAUTION Fire and explosion hazard. Only use approved Propane cylinders with an Overfilling Prevention Device (OPD) valve. Always keep the tank in a vertical position with the valve on top and placed at ground level on a flat surface. Do not allow tanks to be near any heat source. When transporting and storing, turn the propane cylinder valve to the fully closed position and disconnect the tank. Be sure to always cover the generator inlet and tank outlet with protective plastic caps.

- LPG/Propane is highly flammable and explosive.
- In case of a LPG/Propane fire, **DO NOT** attempt to extinguish the flame if the fuel valve is in the gas position. Introducing an extinguisher to a generator with an open fuel valve could create an explosion hazard.
- LPG/Propane can settle in low places because it is heavier than air.
- LPG/Propane has a distinctive odor added to help detect potential leaks. If there is a smell, **DO NOT** use the engine.
- Always keep a propane cylinder in an upright position.
- When exchanging propane cylinders, be sure the tank valve is the same type.
- LPG/propane will burn the skin. Prevent skin contact at all times.
- Keep the propane cylinder away from the generator exhaust.
- Large (500–1000 gallon) propane cylinders will require a certified plumber to install the fuel line to the generator and the loose regulator is not used (the regulator that is attached to the fuel tank). The pressure as measured at the regulator mounted to the generator must be 7 in. to 14 in. of water column. A certified plumber must ensure that the pressure is correct or install a step down regulator if needed.
- Be sure the generator and propane cylinder are on a flat surface before operating.
- If there is a propane odor do not start the unit because there may be a potential leak. Never place a propane cylinder near the engine exhaust.
- When transporting, be sure the propane cylinder and LPG/propane hose are not attached to the generator.
- Store propane cylinder away from sparks, open flames, pilot lights, heat, and other sources of ignition.
- Do not store propane cylinder near furnaces, water heaters, or any other appliances that produce heat or have automatic ignitions.

FIG. 4

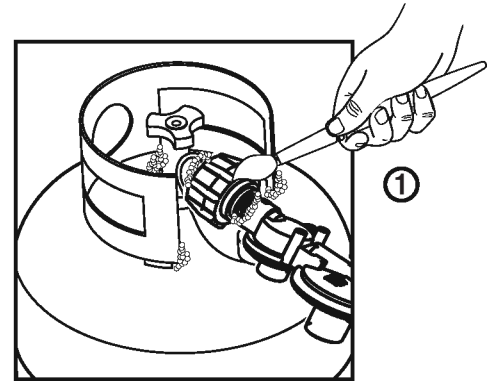

1 - Leak testing with soapy water (Propane)

LEAK TESTING

See Figure 4.

NOTICE Connections on the hose and the propane inlet were tested at the factory to be sure there were no gas leaks. However, shipping and handling may have loosened connections. Always test for leaks before using the generator.

To test for LPG/Propane leaks:

- Connect the LPG/propane hose to the propane inlet on the generator and to the cylinder valve.
- Open the cylinder valve. If there is a rushing sound, immediately turn off the cylinder valve. This noise indicates a significant leak at the connection. Replace the cylinder or have it repaired.
- Brush the inlet, hose connections, and LP gas cylinder with a soapy solution made of a 20/80 mixture of mild soap and water.
- If bubbles begin growing, there is a leak.
 - If the leak is at the inlet, contact customer service. **DO NOT USE THE GENERATOR.**
 - If the leak is at the hose connections, reinstall the hose securely and perform the test again. If the leaks persist, **DO NOT USE THE GENERATOR.**

SAFETY

IMPORTANT INFORMATION FOR THE CO SENSOR

The CO Sensor monitors for the accumulation of poisonous carbon monoxide gas around the generator when the engine is running. If increasing levels of CO gas are detected, the CO Sensor automatically shuts down the engine.

The CO Sensor will also detect the accumulation of carbon monoxide from other fuel burning sources used in the area of operation. For example, if the exhaust of fuel burning tools is pointed at a CO Sensor-equipped generator, a shut-off may be initiated due to rising CO levels. This is not an error. Hazardous carbon monoxide has been detected. Move and redirect any additional fuel burning sources to dissipate carbon monoxide away from personnel and occupied buildings.

NOTE: Remote start-equipped generators must be restarted with the START/STOP button on the control panel after an automatic shut-down occurs.

Generators are intended to be used outdoors, far from occupied buildings and the exhaust pointed away from personnel and buildings. If misused and operated in a location that results in the accumulation of CO, like in a partially enclosed area, the CO Sensor shuts off the engine and the RED indicator light will flash, notifying the user that there are unsafe levels of carbon monoxide.

If the generator shuts off and the RED indicator light flashes, leave the area immediately. Wait for the carbon monoxide to dissipate and the RED indicator light to turn off before returning to the affected area. Once it is safe to return, read the Action Label for further steps to take. The CO Sensor DOES NOT replace carbon monoxide alarms. Install battery-powered carbon monoxide alarm(s) in the house.

⚠ WARNING Automatic shut off accompanied with a flashing RED light in the CO Sensor portion of the control panel is an indication that the generator was improperly located which allowed carbon monoxide to accumulate to unsafe levels. If feeling sick, dizzy, weak, or carbon monoxide detectors indicate an alarm, get to fresh air immediately. Call emergency services. This may be carbon monoxide poisoning.

UNDERSTANDING THE CO SENSOR INDICATOR LIGHTS

See Figure 5.



COLOR	DESCRIPTION
<p>RED</p> 	<p>Unsafe levels of carbon monoxide accumulated around the generator. After shut-off, the RED indicator light in the CO Sensor area of the control panel will flash to provide notification that the generator was shut-off due to carbon monoxide levels rising above a safe threshold. The RED light will flash for at least five minutes after a CO shut-off.</p> <p>When it is safe to do so, move the generator to an open, outdoor area far away from occupied spaces with exhaust pointed away. Once relocated to a safe area and the red light is off, the generator can be restarted. Introduce fresh air and ventilate the area where the generator had shut down.</p>
<p>YELLOW</p> 	<p>A CO sensor system fault occurred. When a system fault occurs, the generator is automatically shut down and the YELLOW indicator light in the CO auto-shut off area of the control panel will flash to provide notification that a fault has occurred. The YELLOW light will flash for at least five minutes after a fault. The generator can be restarted but may continue to shut off. A CO sensor fault can only be diagnosed and repaired by an authorized Westinghouse service center.</p>

FIG. 5



1 - CO sensor indicator light

SAFETY

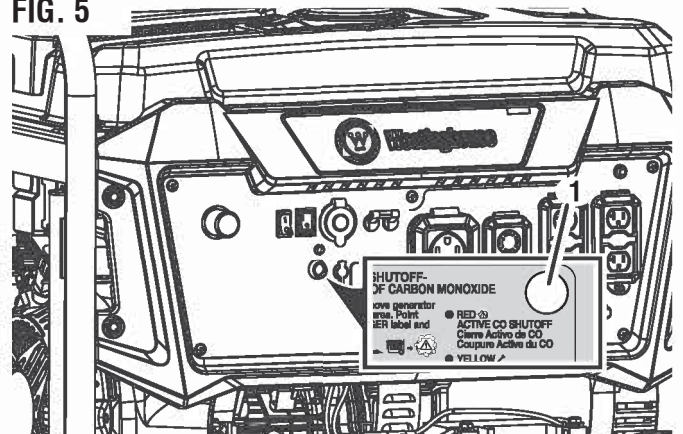
SAFETY LABELS AND DECALS

The following information is on the labels and decals. See the Safety Labels and Decals table for more information.

1 ON LABEL

AUTOMATIC SHUTOFF - YOU MUST:
ETIQUETA DE FUNCIONAMIENTO:
ÉTIQUETTE D'ACTION

- MOVE GENERATOR TO AN OPEN, OUTDOOR AREA.
- POINT EXHAUST AWAY.
- POINT AWAY GENERATOR IN ENCLOSED AREAS (E.G. NOT IN HALLS OR BATHS).
- MOVER LE GENERADOR A UN AREA ABIERTA, DE EXTERIORS.
- PUNTEO LA GÉNÉRATRICE EN UN ESPAZIO ABIERTO (E.G. NO EN UN PASADIZO O BAÑO).
- MOVER EL GENERADOR EN UN ESPAZIO ABIERTO.
- PUNTEO LA GÉNÉRATRICE EN UN ESPAZIO ABIERTO (E.G. NO EN UN PASADIZO O BAÑO).
- MOVER EL GENERADOR EN UN ESPAZIO ABIERTO.

WARNING
ADVERTENCIA
AVERTISSEMENT

TAMPERING WITH CARBON MONOXIDE SENSOR COULD RESULT IN HAZARDOUS CONDITION
INTERFERENCIA CON EL SENSOR DE MONÓXIDO DE CARBONO PUEDE ENTORPECER SUS OPERACIONES PELIGROSAS

MOVE TO FRESH AIR.
• GET MEDICAL HELP IF SICK, DIZZY OR WEAK.
• MOUVEN AL AIR FRESH
• OBTENIR SECOURS MÉDICAL SI SE SIENTE ENFERMO, MAREADO O DÉBIL.
• TOUT SÉJOUR À L'INTÉRIEUR
• CONSULTER UN MÉDECIN SI VOUS ÊTES MALADE, ÉTANNOU OU FAIBLE

POINT ORIENTAR DIRIGIR
EXHAUST
EL TUBO DE ESCAPE
L'ÉCHAPPEMENT
AWAY
HACIA AFUERA
LOIN DE VOUS

2 DANGER

Using a generator indoors CAN KILL YOU IN MINUTES.
Generator exhaust contains carbon monoxide. This is a poison you cannot see or smell.

NEVER use inside a home or garage, EVEN IF doors and windows are open.

Only use **OUTSIDE** and far away from windows, doors, and vents.

3 TAKE GENERATOR OUTSIDE

Generators are intended to be used outdoors, far from occupied buildings and the exhaust pointed away from personnel and buildings. This generator is equipped with a carbon monoxide auto-shutoff system (CO Sensor). The CO Sensor monitors for the accumulation of poisonous carbon monoxide (CO) gas around the generator when the engine is running. If the generator is operated in a location that results in the accumulation of CO and increasing levels of CO gas are detected, the CO Sensor is designed to shut down the engine and notify the user with a red indicator light.

THE CO SENSOR DOES NOT REPLACE CARBON MONOXIDE ALARMS.

Install battery-powered carbon monoxide alarms (a) in your home or plug-in carbon monoxide detectors with battery back-up in living areas.

Refer to the User Manual and Action Label located on top of generator for steps to take.

Disconnecting or modifying the CO sensor will make the generator inoperable.



6 Westinghouse

Westinghouse Outdoor Power Equipment
Columbus Ohio 43228 USA

Made in: Model: WGen9500DFc EFI

Rev. Level Révision		Power (Rated) Puissance (Nom.)	9500W GAS 8500W LPG	Insul Class Classe Discol.	H
Phase	Single	Power (Peak) Puissance (Pointe)	12500W GAS 11200W LPG	Max Amb Temp Temp. Amb. Max	40°C (104°F)
AC Voltage Tension CA	120/240V	Frequency Fréquence	60Hz	Duty Service	S1
AC Current Intensité CA	40A GAS 35A LPG	RPM TR/MIN	3600rpm	Power Factor Facteur de puissance	1.0

Serial No./No. De Série:

Register your product:

7 CAUTION HOT SURFACES
PRECAUCIÓN SUPERFICIES CALIENTES
ATTENTION AUX SURFACES CHAUDES

8 DANGER PELIGRO DANGER

Read User Manual before operating generator. Gasoline and LPG/propane is highly flammable. Leaking gasoline or LPG can cause a fire or explosion if ignited. If you smell gasoline or propane while operating the unit, immediately shut OFF the fuel and/or propane valve. Keep gasoline container and propane tank away from exhaust.

Lea el manual del propietario antes de operar el generador con GLP / propano. GLP / propano es altamente inflamable. La fuga de gas LP puede causar un incendio o una explosión si se enciende. Si huele a propano mientras está operando la unidad, apague inmediatamente la válvula de propano. Mantenga el tanque de propano lejos del escape.

Lisez le manuel du propriétaire avant d'utiliser le générateur sur le propane. Le propane est hautement inflammable. Une fuite de gaz peut provoquer un incendie ou une explosion si elle s'allume. Si vous sentez le propane pendant que vous utilisez l'unité, fermez immédiatement la vanne de propane. Gardez le réservoir de propane à l'écart de l'échappement.

9 CAUTION! OIL HAS BEEN DRAINED FOR SHIPPING

Follow to fill engine with oil before starting will result in engine damage and voids warranty. USE SAE TOWNSHIP OIL (1.0 or 1.1).

FILE: 0008 847 ALJL 02 PRECET 0001 001 001 FACTORY TOWNSHIP

10 CAUTION TURN OFF PROPANE SOURCE:

- When generator is off
- When operating generator on gas

PRECAUCIÓN APAGUE LA FUENTE DE PROPANO:

- Cuando el generador está apagado
- Cuando se opera generador en gas

MISE EN GARDE ÉTEIGNEZ LA SOURCE DE PROPANE:

- Lors de l'utilisation de la génératrice au gaz

11 MAINTAIN AIR CLEANER / MANTENGA EL FILTRO DE AIRE / ENTRETIEN DU FILTRE À AIR

Clean the air filter with compressed air once every 50 hours (every 10 hours if operating in dusty conditions). Replace air filter if damaged.

Limpie el filtro de aire con aire comprimido una vez cada 50 horas (cada 10 horas en condiciones industriales). Reemplazale el filtro de aire si está dañado.

Nettoyez le filtre à air avec de l'air comprimé toutes les 50 heures (toutes les 10 heures en cas de fonctionnement dans des conditions industrielles). Remplacez le filtre à air s'il est endommagé.

FOR TECHNICAL ASSISTANCE or SERVICE CALL TOLL FREE
Para la ayuda técnica y servicio llámada
1-855-944-3571

3 YEAR LIMITED WARRANTY

13 DANGER PELIGRO DANGER

<p>Failure to follow warnings, instructions and operator manual will result in death or serious injury.</p> <p>Generator could cause electrical shock.</p> <ul style="list-style-type: none"> • ONLY use in dry conditions. • DO NOT operate in rain or wet weather. • A generator electric shock could occur when connecting to a building. 	<p>No obedecer las advertencias e instrucciones y el manual del operador provocará lesiones graves o la muerte.</p> <p>El generador podría causar una descarga eléctrica.</p> <ul style="list-style-type: none"> • No opere en interiores para evitar condiciones de humedad. • No opere en la lluvia ni en clima húmedo. • No conectar el sistema eléctrico de una casa. 	<p>Le non-respect des avertissements, des instructions et du manuel de l'utilisateur entraînera la mort ou des blessures graves.</p> <p>Le générateur pourrait provoquer un choc électrique.</p> <ul style="list-style-type: none"> • Ne courez pas à l'intérieur pour éviter les conditions humides. • Ne courez pas sous la pluie ou par temps humide. • Ne vous connectez pas au système électrique d'une maison.
<p>Never fuel unit with engine running. Always fuel in well ventilated area. Always allow unit to cool before fueling.</p> <p>Hot muffler and exhaust gases can cause fires. Keep at least 5ft (1.5 m) clearance from any combustible or structure, including overhead.</p> <p>Exhaust contains poisonous carbon monoxide gas that can cause unconsciousness or DEATH. Install Carbon Monoxide alarm inside home.</p> <p>For electrical equipment only. Failure to properly ground generator can result in electrocution.</p>	<p>Nunca cargue la unidad con el motor en marcha. Cargue siempre en un área bien ventilada. Siempre deje que el motor se enfríe antes de cargar combustible.</p> <p>Los gases calientes del escape podrían causar un incendio. Déje un espacio libre de al menos 1.5 m de cualquier combustible o estructura, incluyendo por encima.</p> <p>Los gases de escape contienen monóxido de carbono venenoso que puede causar pérdida del conocimiento o la MUERTE. Instale alarmas de monóxido de carbono dentro de la casa.</p> <p>Solo para equipo eléctrico. No conectar a tierra incorrectamente el generador puede provocar una electrocución.</p>	<p>Ne faites jamais de carburant avec le moteur en marche. Faites toujours le plein dans un endroit bien ventilé. Laissez toujours l'appareil refroidir avant de faire le plein.</p> <p>Les gaz d'échappement chauds peuvent provoquer des incendies. Gardez un dégagement d'au moins 1,5 m de tout combustible ou structure, y compris les toits intérieurs.</p> <p>Les gaz d'échappement contiennent du monoxyde de carbone gazeux toxique qui peut provoquer une perte de conscience ou la MORT. Installez des avertisseurs de monoxyde de carbone à l'intérieur de la maison.</p> <p>Pour les équipements électriques uniquement. Une mauvaise mise à la terre du générateur peut entraîner une électrocution.</p>

SAFETY

SAFETY LABELS AND DECALS TABLE		
INDEX NUMBER	ITEM	DESCRIPTION
1	Action label	If unsafe levels of carbon monoxide accumulate around the generator, automatic shut off will occur. If the unit shuts off, leave the area immediately. When it is safe to return, do the following: <ul style="list-style-type: none"> • Move the generator to an open, outdoor area. • Point exhaust away. • Don't run generator in enclosed areas (e.g. not in house or garage). • Move to fresh air. • Get medical help if sick, dizzy or weak. • WARNING – Tampering with carbon monoxide sensor could result in hazardous condition.
2	Carbon monoxide	<ul style="list-style-type: none"> • Using a generator indoors CAN KILL YOU IN MINUTES. Generator exhaust contains carbon monoxide. This is a poison you cannot see or smell. • NEVER use inside a house or a garage, EVEN IF doors and windows are open.
3	Take generator outside	Generators are intended to be used outdoors.
4	Pinch point hazard	Keep fingers and hands away from pinch point.
5	Adding oil	Add engine oil until the oil level is within safe operating range.
6	Specifications	(See page 3)
7	Hot surface	Do not touch.
8	Danger label	Read User Manual before operating generator. Gasoline, and LPG/Propane is highly flammable. Leaking gasoline, or LPG can cause a fire or explosion if ignited. If you smell gasoline, or propane while operating the unit, immediately shut OFF the fuel and/or propane valve. Keep gasoline container, and propane cylinder away from exhaust.
9	No oil	Oil has been drained from the unit for shipping. Add oil before operating the unit.
10	Caution label	Turn off propane when the generator is off or when the generator is using gas.
11	Maintain air cleaner	Clean air filter every 50 hours (every 10 hours if operating in dusty conditions).
12	Customer service	For technical assistance or service call 1-855-944-9571
13	Safety symbols	(See page 4)

ELECTRICAL

GENERATOR CAPACITY

NOTICE Do not overload the capacity. Exceeding the wattage/amperage capacity can damage the generator and/or electrical devices connected to it.

Review the Specifications for this generator and record the running (continuous) and peak (starting) watts. In general the higher the wattage, the more devices can be powered at the same time. The total power requirements of all connected devices must be considered. Power requirements are often listed on a data label or nameplate.

To determine power requirements:

- Choose the devices to power simultaneously.
- Record and total the running (continuous) watts of each device. The generator must continuously produce this amount of wattage to keep the devices running.
- Record the peak (starting) watts for each device. This is the momentary surge of power required to start electric motors in some tools and appliances.
- Select the device with the highest peak (starting) wattage. Add the peak (starting) watts for that device to the total running (continuous) watts for all the connected devices to determine the total peak wattage requirement for the generator.

NOTE: Total peak wattage requirement assumes intermittent starting of devices. Adjust estimate if devices reach peak wattage at the same time.

MANAGING GENERATOR POWER

To extend the service life of the generator, use caution when adding electrical loads. Disconnect all loads before starting the generator. The safest way to manage generator power is to add loads sequentially by doing the following:

- Remove all loads and start the generator as described later in this manual.
- Connect and start the largest device or appliance. Power requirements are often listed on a data label or nameplate.
- Allow the generator output to stabilize. Once stable, the engine should run smoothly and the device should function properly.
- Connect and start the next largest device or appliance.
- Allow the generator output to stabilize.
- Repeat this process for each additional load.

EXTENSION CORDS

WARNING Asphyxiation hazard. Extension cords running directly into the house increase the risk of carbon monoxide poisoning through any openings. If an extension cord running directly into the house is used to power indoor items, there is a risk of carbon monoxide poisoning to people inside the house. Always use battery-powered carbon monoxide detector(s) that meet current UL 2034 safety standards when running the generator. Regularly inspect the detector(s) battery.

WARNING Asphyxiation hazard. When operating the generator with extension cords, be sure the generator is located in an open, outdoor area far away from occupied spaces with exhaust pointed away.

WARNING Fire and electrocution hazard. Never use worn or damaged extension cords. Damaged or overloaded extension cords could overheat, arc, and burn resulting in death or serious injury.

Before connecting an AC appliance or power cord to the generator:

- Use grounded 3-prong extension cords, tools, and appliances, or double-insulated tools and appliances.
- Be sure the tool or appliance is in good working order. Faulty appliances or power cords can create a potential for electric shock.
- Be sure the electrical rating of the tool or appliance does not exceed the rated power of the generator or the receptacle being used.

NOTICE Do not exceed the capacity. Overloading the wattage and/or amperage capacity could damage connected devices and critical generator components.

EXTENSION CORD SIZING

Be sure the extension cord can carry the required load. Cables that are too small may cause a voltage drop that can cause the cord to overheat or cause property damage. Refer to the cord manufacturer's guidelines for the appropriate size and length.

COMPONENTS

FIG. 6

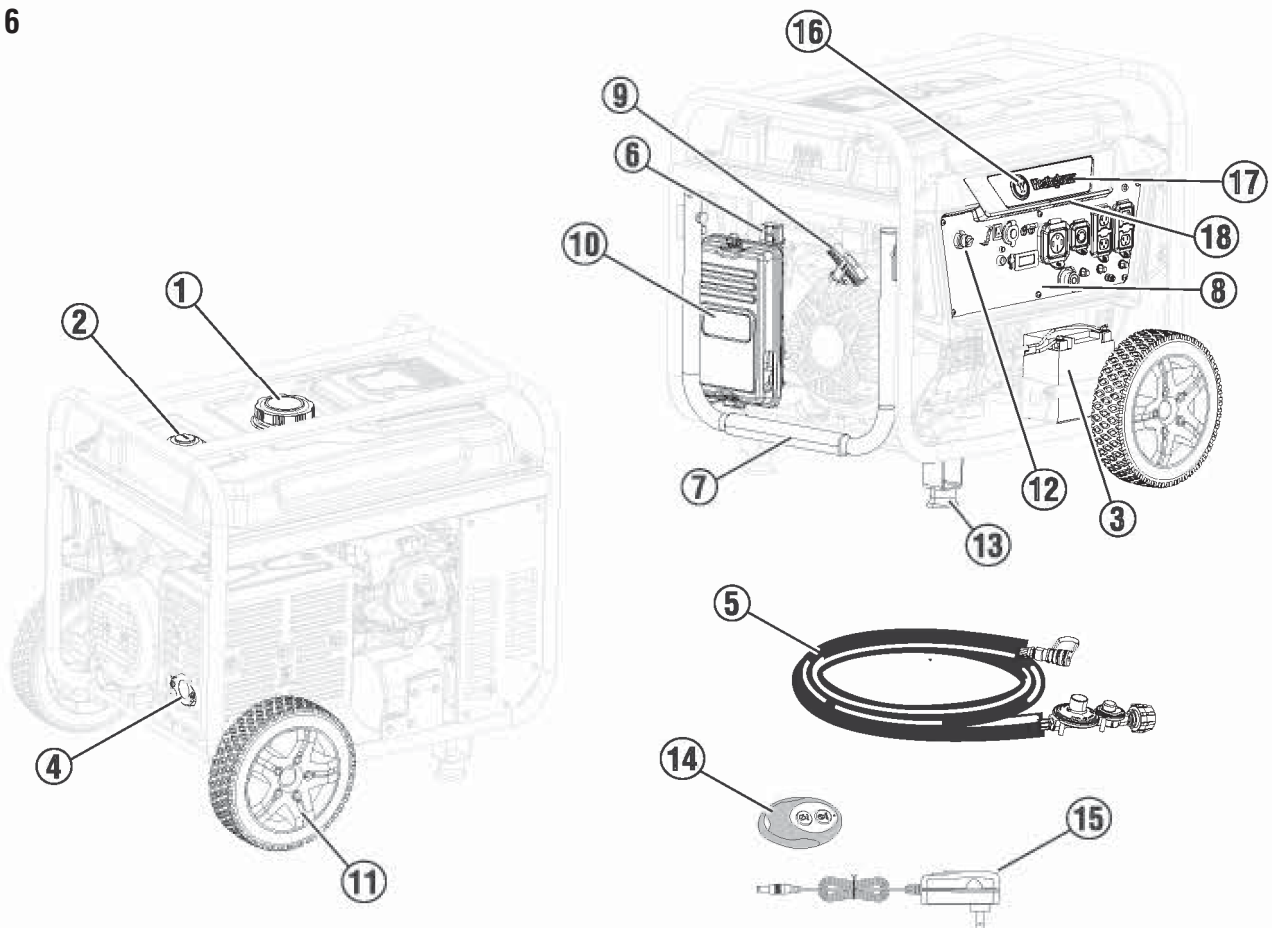

- | | | |
|-------------------------------------|-----------------------|-------------------------------|
| 1 - Fuel cap | 8 - Control panel | 14 - Key fob |
| 2 - Fuel gauge | 9 - Recoil handle | 15 - Charger |
| 3 - Battery | 10 - Air filter cover | 16 - Engine Start/Stop button |
| 4 - Muffler/Spark Arrestor | 11 - Wheel | 17 - Westinghouse light |
| 5 - LPG hose and regulator assembly | 12 - Propane inlet | 18 - LED light strip |
| 6 - Throttle body | 13 - Stabilizer | |
| 7 - Handle | | |

UNDERSTANDING THE GENERATOR

See Figures 6 - 7.

To reduce the risk of injury and product failure, read and understand the information in this user manual as well as the information on the product labeling.

120V AC, 20 AMP RECEPTACLES

This unit has two single phase, 60 Hz receptacles capable of carrying a maximum of 20 amps.

120V / 240V AC, 50 AMP RECEPTACLES

This receptacle can supply either 120V or 240V up to 50 amps.

BATTERY CHARGING PORT

Use the battery charging port along with the included battery charger to charge the battery.

BATTERY INDICATOR

Indicates that battery power is available. Light will remain illuminated while the battery has charge.

BATTERY SWITCH

Enables or disables electric start. The battery switch must be in the ON position to use remote start.

WESTINGHOUSE LIGHT

The lights are set to automatically turn on and off. Once the generator is successfully started, the lights are automatically turned on, and the system will automatically turn off the lights when the generator stops running. The light can be turned on or off manually by pressing the LED switch on the control panel for 0.5 seconds.

NOTE: When the generator stops running, leaving the lights on for a long time can lead to excessive drain on the battery current.

CIRCUIT BREAKERS (20 AMP AND 30 AMP)

The circuit breakers protect individual circuits from electrical overload.

NOTE: The 20 amp circuit breaker limits the current that can be delivered through the 5-20R GFCI receptacles to 20 Amps and the 30 amp circuit breaker limits the current for the L14-30R receptacle to 30 amps.

COMPONENTS

FIG. 7

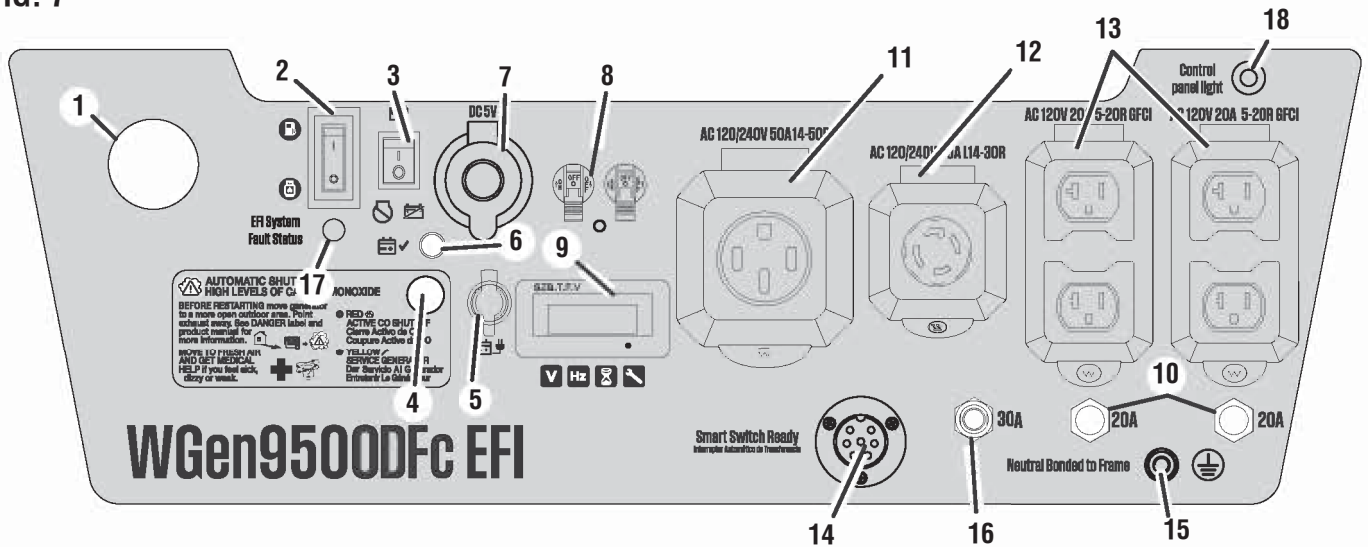

- | | | |
|-------------------------------|--|--|
| 1 - Propane inlet | 7 - USB ports | 13 - 120 volt AC 20 amp GFCI receptacles |
| 2 - Fuel selector switch | 8 - Main circuit breaker | 14 - Smart switch outlet |
| 3 - Battery switch | 9 - Data center | 15 - Ground terminal |
| 4 - CO sensor indicator light | 10 - 20 amp circuit breakers | 16 - 30 amp circuit breaker |
| 5 - Battery charging port | 11 - 120/240 volt AC 50 amp receptacle | 17 - EFI status indicator |
| 6 - Battery indicator | 12 - 120/240 volt AC 30 amp receptacle | 18 - LED switch |

CO SENSOR INDICATOR LIGHTS

The CO Sensor monitors for the accumulation of poisonous carbon monoxide gas. If increasing levels of CO gas are detected, the CO Sensor automatically shuts down the engine.

DATA CENTER

Displays voltage, frequency, total hour meter, and run/maintenance timer.

ENGINE START/STOP BUTTON

Push once to automatically start the engine. Push again to stop the engine.

FUEL SELECTOR SWITCH

Use the fuel selector switch to choose a gasoline or propane fuel source.

FUEL TANK

The generator has a fuel tank with a capacity of 6.6 gallons.

NOTE: The fuel gauge on top of the tank shows the approximate fuel level.

GROUND TERMINAL

The ground terminal is used to externally ground the generator.

MAIN CIRCUIT BREAKER

The main circuit breaker controls total output of all outlets to protect the generator from overload or short circuit.

MUFFLER AND SPARK ARRESTOR

The spark arrestor prevents sparks from exiting the muffler. It must be removed for servicing.

NOTICE

The spark arrestor is a safety device that prevents sparks from exiting the muffler and creating a fire hazard. In certain locations a spark arrestor may be required by law. It is the operator's responsibility to know and follow all local laws and regulations related to fire prevention requirements.

OIL DIPSTICK

Unscrew the oil dipstick to inspect oil levels and add oil when needed.

RECOIL HANDLE

Use the recoil handle (along with the fuel valve and choke) to manually start the generator.

REMOTE START

Use the key fob to start the generator remotely.

SMART SWITCH OUTLET

The smart switch outlet enables a connection to be made between the Westinghouse ST Switch (sold separately) to the generator.

EFI STATUS INDICATOR

When the generator is powered on, the EFI indicator light will perform a 2-second constant-on self-check. After the self-check is complete, the fault light will flash to indicate that there is a fault with the generator. In this case, the generator should be repaired by a technician before it can be used normally. For more information, please contact customer service.

ASSEMBLY

WARNING Weight hazard. Always have assistance when lifting the generator. Never attempt to lift the unit by the handle. Hold the unit by the frame and use proper lifting techniques to reduce the risk of back injury.

REMOVING CARTON CONTENTS

WARNING This product requires assembly. Do not attempt to operate this product if any items in the **INCLUDED LIST** are already assembled when removing the carton contents. These items are not assembled by the manufacturer and should require customer assembly. Using an improperly assembled product can be hazardous and could result in serious personal injury.

- Carefully cut down the sides of the packaging and remove the carton contents.
- Inspect the carton contents. Confirm that all the items in the **INCLUDED LIST** are present and undamaged.
- Recycle or dispose of the packaging materials properly.

INCLUDED LIST <i>See Figure 8.</i>		
INDEX NUMBER	DESCRIPTION	QUANTITY
1	Wheel	2
2	Axle	2
3	Washer	2
4	Hitch pin	2
5	LPG hose and regulator assembly	1
6	Key fob	1
7	Bolt	4
8	Stabilizer	2
9	Oil bottle	1
10	Battery charger	1
*	Funnel	1
*	Spark plug wrench	1
* Not shown		

If any parts are missing, contact our service team at service@wpowereq.com or call 1-855-944-3571.

FIG. 8

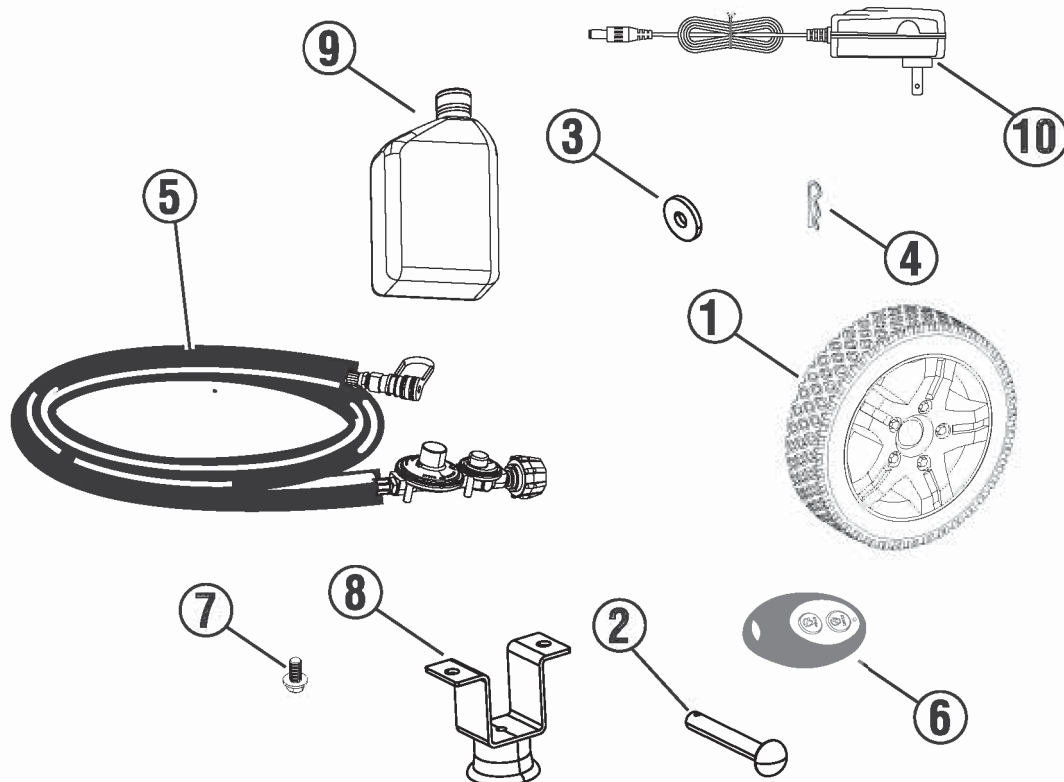

ASSEMBLY

INSTALLING THE STABILIZERS

See Figure 9.

1. Place the generator on a flat surface.
2. Lift the handle side of the generator high enough to gain access to the crossbar on the bottom of the frame.
3. Place props beneath the generator to serve as a temporary support.
4. Locate the stabilizer and bolts.
5. Align the holes in the stabilizer with the nuts in the crossbar.
6. Insert bolts through the holes in the stabilizer and nuts in the crossbar.
7. Tighten bolts securely. **Do not overtighten.**
8. Repeat these steps to install the second stabilizer.

FIG. 9

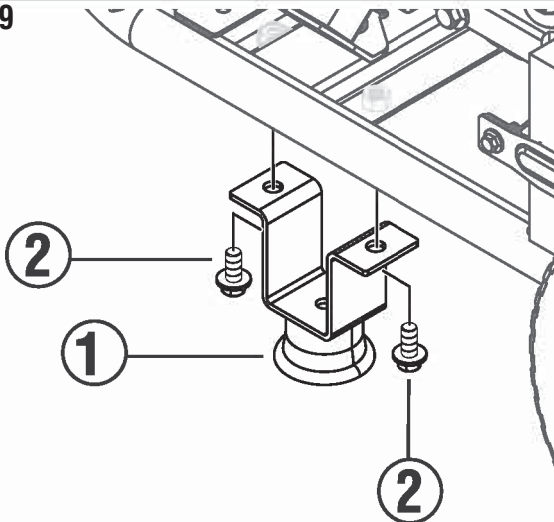

- 1 - Stabilizer
- 2 - Bolt

FIG. 10

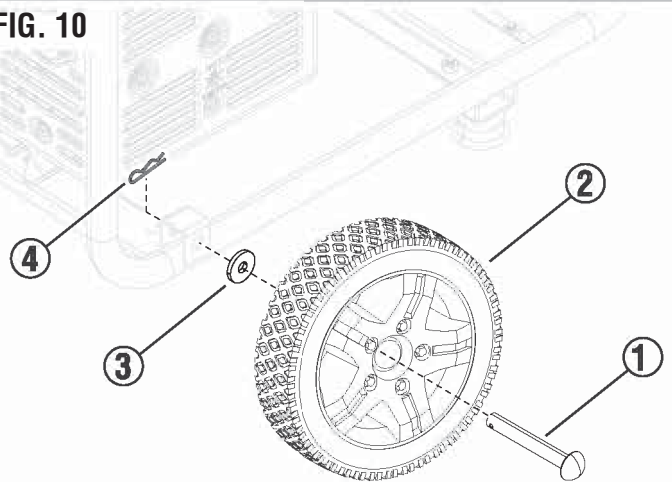

- 1 - Axle
- 2 - Wheel
- 3 - Washer
- 4 - Hitch Pin

INSTALLING THE WHEELS

See Figure 10.

1. Place the generator on a flat surface.
2. Lift the muffler side of the generator high enough to gain access to the bottom of the frame.
3. Place props beneath the generator to serve as a temporary support.
4. Locate the axles, wheels, washers, and hitch pins.
5. Insert an axle through the middle of a wheel, washer, and the frame as shown.
6. Push a hitch pin into the axle until the center of the pin rests against the top of the axle.
7. Repeat these steps to install the second wheel.

CONNECTING THE BATTERY

See Figure 11.

A quick-connect battery cable is pre-installed on the battery. Remove the cable tie securing the plugs then push firmly to connect them.

NOTE: The generator is equipped with a battery charging feature. Once the engine is running, a small charge will slowly recharge the battery.

FIG. 11

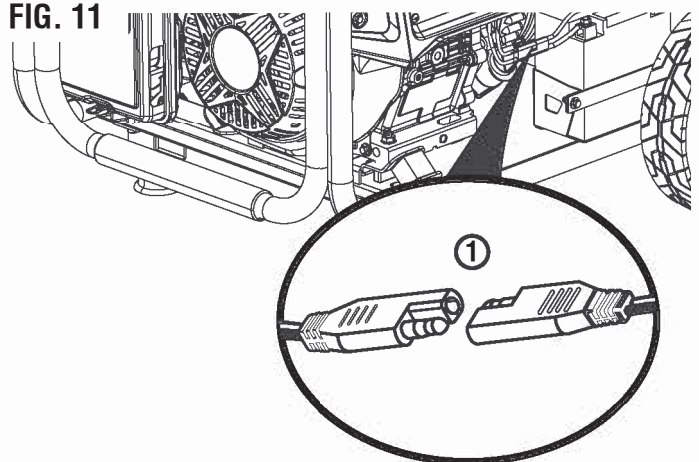

- 1 - Quick-connect battery cable

ASSEMBLY

RAISING/LOWERING THE HANDLE

See Figure 12.

1. Stand in front of the unit, grasp the handle firmly and lift it to the raised position.
2. With the handle in the raised position, the generator can safely be rolled from one position to another. For information regarding transporting the unit in a vehicle, refer to the **Transporting** section in *Operation*.
3. To lower the handle, gently guide the handle to the down position.



CAUTION

Pinch point hazard. Do not place body parts between the handle and the frame.



WARNING

Do not alter or modify this product unless instructed to do so in this manual or by the manufacturer. Do not use attachments or accessories that are not recommended for use with this product. Making unauthorized modifications and using incompatible accessories can damage the unit and void the warranty.

FIG. 12

1 - Handle

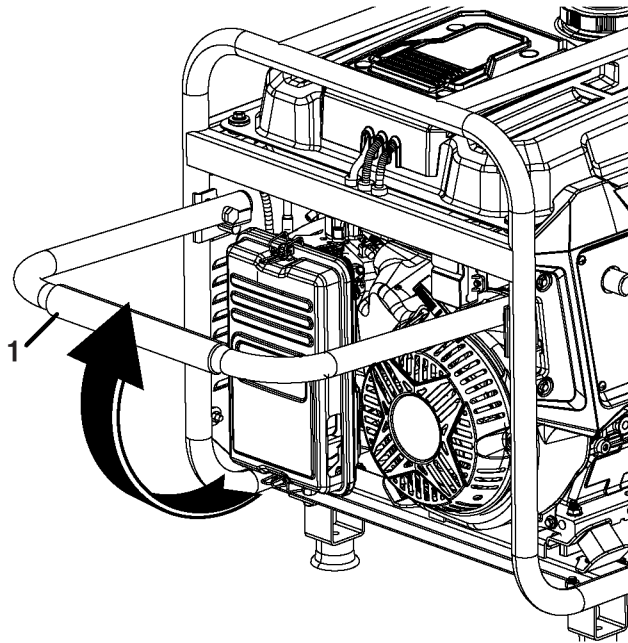

NOTICE

Do not attempt to crank or start engine before it has been properly serviced with recommended oil. Failure to add engine oil before starting will result in serious engine damage that is not covered under warranty.

OPERATION

⚠ DANGER Generator exhaust contains high levels of carbon monoxide (CO), an invisible, odorless, and extremely poisonous gas. If you smell exhaust fumes, you are breathing carbon monoxide. But, even if you do not smell exhaust fumes, you may be inhaling CO.

ONLY operate generators outside, in a well-ventilated area. NEVER operate generators indoors, doing so CAN KILL YOU IN MINUTES.

- **Correct Use** – ONLY use generators outside and downwind, far away from windows, doors and vents. ALWAYS direct exhaust away from occupied spaces. ALWAYS install battery-powered carbon monoxide detectors or plug-in carbon monoxide detectors with battery back-up in living areas. *See Figure 1.*
- **Incorrect Use** - NEVER use a generator in a house, garage, basement, attic, crawl space or any other fully or partially enclosed area. Areas such as these can allow dangerous levels of carbon monoxide to accumulate. An open door or a running fan WILL NOT provide adequate ventilation. *See Figure 2.*

If feeling dizzy, weak, or sick while using the generator, move to fresh air immediately. Contact a doctor. This may be carbon monoxide poisoning.

⚠ WARNING Do not alter or modify this product unless instructed to do so in this manual or by the manufacturer. Do not use attachments or accessories that are not recommended for use with this product. Making unauthorized modifications and using incompatible accessories can damage the unit and may void the warranty.

NOTICE In certain circumstances, the National Electric Code may require the generator to be grounded to an approved earth. Consult with a qualified electrician to determine grounding requirements before operation.

⚠ WARNING Avoid skin contact with engine oil or gasoline. Wear protective clothing and equipment. Wash all exposed skin with soap and water. Prolonged skin contact with gasoline or engine oil may cause severe skin irritation and other adverse reactions.

NOTICE Inspect the physical condition of the product prior to each use. Look for loose bolts, fluid leaks, and other signs of wear. Replace all damaged items.

NOTICE Be sure the wheels and stabilizers are properly installed before adding fuel or oil.

KNOW HOW TO SAFELY LOCATE AND OPERATE THE GENERATOR

⚠ DANGER Asphyxiation hazard. Place the generator in a well-ventilated area. DO NOT place the generator near vents or intakes where exhaust fumes could be drawn into occupied or confined spaces. Carefully consider wind and air currents when positioning the generator.

⚠ WARNING Electrocutation hazard. Never use the generator in a location that is wet or damp. Never expose the generator to rain, snow, water spray, or standing water while in use. Protect the generator from all hazardous weather conditions. Moisture or ice can cause a short circuit or other malfunction in the electrical circuit. Using a generator or electrical appliance in wet conditions, such as rain or snow, or near a pool or sprinkler system, or with wet hands, could result in electrocution.

⚠ WARNING Fire hazard. Only operate the generator on a solid, level surface. Operating the generator on a surface with loose material such as sand or grass clippings can cause debris to be ingested by the generator that could block cooling vents or the air intake system. Allow the generator to cool for 30 minutes before transport or storage.

- Read and understand all safety information before starting the generator (see pages 4 – 12).
- NEVER use a generator in a house, garage, basement, attic, crawl space or any other fully or partially enclosed area. Areas such as these can allow dangerous levels of carbon monoxide to accumulate. Carbon monoxide (CO), an invisible, odorless, and extremely poisonous gas CAN KILL YOU IN MINUTES.
- DO NOT operate the generator in the back of a SUV, camper, trailer, truck bed (regular, flat, or otherwise), under stairs, next to walls or buildings, or in any other location that will not allow for adequate cooling of the generator and/or the muffler. Operating the generator in enclosed or partially enclosed areas will allow dangerous levels of CO to accumulate.
- DO NOT enclose generators during operation.
- Only use OUTSIDE and far away from windows, doors, and vents as recommended by the US Department of Health and Human Services Centers for Disease Control and Prevention. Specific houses and/or wind conditions may require additional distance.
- Do not operate the generator on an incline. The unit should always be placed on a flat stable surface.
- The generator should be on a flat, level surface at all times (even while not in operation).
- The generator must have at least 5 ft. (1.5 m) of clearance from all combustible material.

KNOW THE REGULATIONS FOR THE USE OF PORTABLE GENERATORS

Consider where and how the generator will be used, and become familiar with any local, state, or federal ordinances concerning the intended use. It may be necessary to contact a qualified electrician or local governing agency for a full list of requirements.

OPERATION

ADDING OIL/INSPECTING OIL LEVEL

See Figure 13.

NOTICE

Do not attempt to crank or start engine before it has been properly serviced with recommended oil. Failure to add engine oil before starting will result in serious engine damage that is not covered under warranty.

NOTICE

Use of 2-stroke/cycle oil or other unapproved oil types can cause severe engine damage that is not covered under warranty.

The included, recommended oil type for typical use is 10W-30 engine oil. If running the generator in extreme temperatures, refer to the following chart.

Recommended Engine Oil Type									
		10W-30							
	← 5W-30						10W-40 →		
	5W-30 Synthetic								
°F	-20	0	20	40	60	80	100	120	
°C	-28.9	-17.8	-6.7	4.4	15.6	26.7	37.8	48.9	
Ambient Temperature									

NOTE: Inspect the engine oil level before each use or every 8 hours of operation.

- Turn the generator off and allow the engine to cool for at least five minutes.
- Place the generator on a level surface in a well-ventilated area.
- Clean the area around the oil dipstick.

For initial oil fill:

1. Slowly unscrew and remove the oil dipstick.
2. Using the funnel, slowly pour the supplied engine oil into the oil fill hole. Be sure not to overfill.

NOTE: The generator was functionally tested in the factory and may contain minimum residual oil. Additional oil is required to operate the unit. **Do not** overfill.

3. Replace and tighten the oil dipstick.

To inspect oil level:

1. Slowly unscrew and remove the oil dipstick.
2. Clean the dipstick and re-seat it inside the oil fill hole. Do not thread the dipstick.
3. Remove the dipstick and confirm that the oil level is within safe operating range.
4. If the oil level is low, add recommended engine oil incrementally and inspect until the level is within the safe operating range.
5. Replace the oil dipstick and hand-tighten.

FIG. 13

- 1 - Oil Dipstick
- 2 - Safe Operating Range

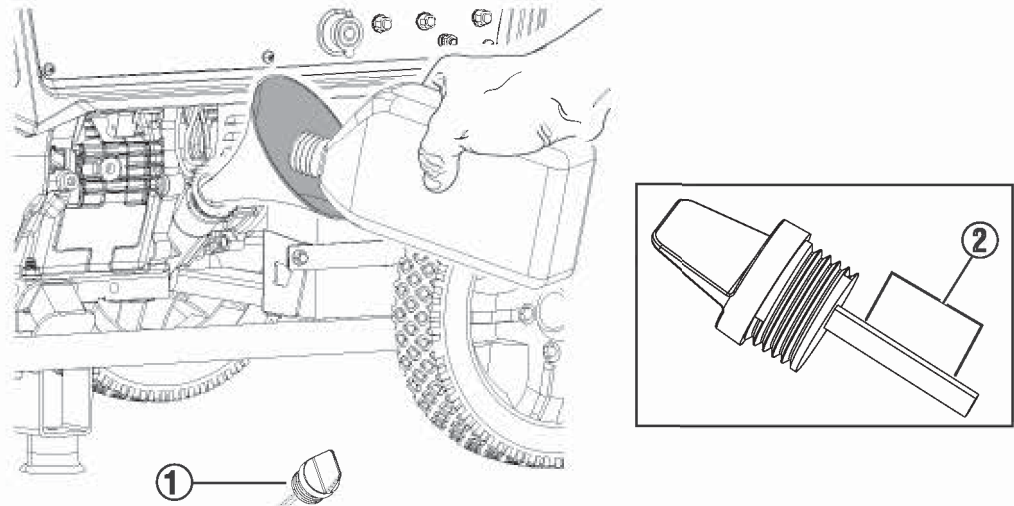

OPERATION

GASOLINE REQUIREMENTS

NOTICE Do not use E15 or E85 fuel in this product. Engine or equipment damage caused by stale fuel or the use of unapproved fuels (such as E15 or E85 ethanol blends) is not covered by warranty. Only use unleaded gasoline containing up to 10% ethanol.

- ALWAYS use CLEAN, FRESH, unleaded gasoline (87–93 octane) in this unit. NEVER use OLD, STALE, or CONTAMINATED gasoline.
- Up to 10% ethanol (gasohol) is acceptable (where available; non-ethanol fuel is recommended).
- DO NOT use E85 or E15.
- DO NOT use a gas oil mix.
- DO NOT modify the engine to run on alternate fuels.



USING FUEL STABILIZER

Adding a fuel stabilizer (not included) extends the usable life of fuel and helps prevent deposits from forming that can clog the fuel system. Follow the manufacturer's instructions for use.

Always mix the correct amount of fuel stabilizer to gasoline in an approved gasoline container before fueling the generator. Run the generator for five minutes to allow the stabilizer to treat the entire fuel system.

ADDING GASOLINE

See Figures 14 - 15.

DANGER Fire and explosion hazard. Never remove the fuel cap or refuel the generator while the engine is running. Do not smoke or create sparks while fueling. Always turn the engine off and allow the generator to cool for at least five minutes before refueling.

DANGER Fire and explosion hazard. Do not overfill fuel tank. Fill only to the red maximum fill ring on the fuel screen. Overfilling may cause fuel to spill onto engine causing a fire or explosion hazard.

WARNING Never use a gasoline container, gasoline tank, or any other fuel item that is broken, cut, torn or damaged.

NOTICE Only fill the tank from an approved gasoline container. Be sure the gasoline container is internally clean and in good condition to prevent fuel system contamination.

1. Turn the generator off and allow the engine to cool for at least five minutes.
2. Place the generator on a level surface in a well-ventilated area.
DO NOT fuel indoors.
3. Clean area around fuel cap and remove the cap slowly.
4. Slowly add the recommended fuel. Do not overfill.

NOTE: The gasoline level should NOT be higher than the red maximum fill ring on the fuel screen.

NOTE: The fuel gauge on top of the tank shows the approximate fuel level.

5. Install the fuel cap. Tighten securely.
6. Clean up any spilled fuel.
7. Move at least 30 ft. away from refueling area before restarting the engine.

FIG. 14

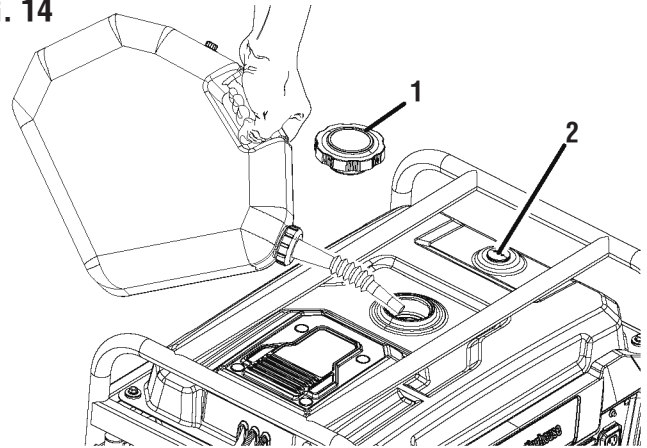

- 1 - Fuel Cap
- 2 - Fuel Gauge

FIG. 15

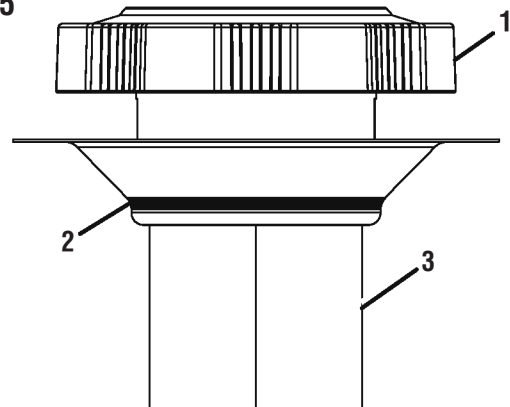

- 1 - Fuel Cap
- 2 - Max Fill Line
- 3 - Screen Filter

OPERATION

NOTICE

Fuel can damage paint and plastic. Use caution when filling the fuel tank. Damage caused by spilled fuel is not covered under warranty.

NOTICE

Clean the fuel screen filter of debris before and after each fueling. Remove the fuel screen filter by slightly compressing it while removing it from the fuel tank.

LP GAS CYLINDER REQUIREMENTS

NOTICE

Propane cylinders that use liquid withdrawal system can not be used on these models.

LP gas is extremely flammable and could ignite spontaneously when mixed with air. The LP gas cylinder used with this generator must meet the following requirements:

- The cylinder must be manufactured and labeled in accordance with the *Specifications for LP Gas Cylinders* of the U.S. Department of Transportation (D.O.T.) or the National Standard of Canada, CAN/CSA-B339, *Cylinders, Spheres, and Tubes for Transportation of Dangerous Goods; and Commission*.
- The cylinder must have a safety relief valve.
- The cylinder must include a UL listed Overfill Protection Device (OPD). Cylinders with this safety feature will have a unique triangular handwheel. Only use LP gas cylinders with this type of handwheel.
- The cylinder must be periodically certified for use by the authority having local jurisdiction (AHJ). Before use, confirm that the certification date on the cylinder has not expired.
- All new cylinders must be purged of air and moisture prior to filling. Used cylinders that have not been plugged or kept closed must also be purged. The purging process should be done by a propane supplier (Cylinders from an exchange supplier should have been purged and filled properly).



CONNECTING AN LP GAS CYLINDER TO THE GENERATOR

See Figures 16 - 17.

DANGER

Fire and explosion hazard. Never connect or disconnect the LPG/propane hose while the engine is running. Do not smoke or create sparks while handling LPG/propane. Always turn the engine off and allow the generator to cool for at least five minutes before connecting the propane cylinder.

WARNING

Never use a gas container, LPG/propane hose, propane cylinder or any other fuel item that appears to be damaged.

WARNING

To reduce the risk of injury, perform a leak test any time the LP gas cylinder is disconnected and reconnected.

1. Turn the generator off and allow the engine to cool for at least five minutes.
2. Place the generator on a level surface in a well-ventilated area. **DO NOT connect or disconnect the LP gas cylinder indoors.**
3. Place the LP gas cylinder near the generator, but **do not place it in the path of the muffler exhaust.**

NOTE: The propane cylinder can be of any capacity but it must conform to the **LP Gas Cylinder Requirements** listed earlier in this section.

4. Confirm that the handwheel is in the fully off position.

FIG. 16

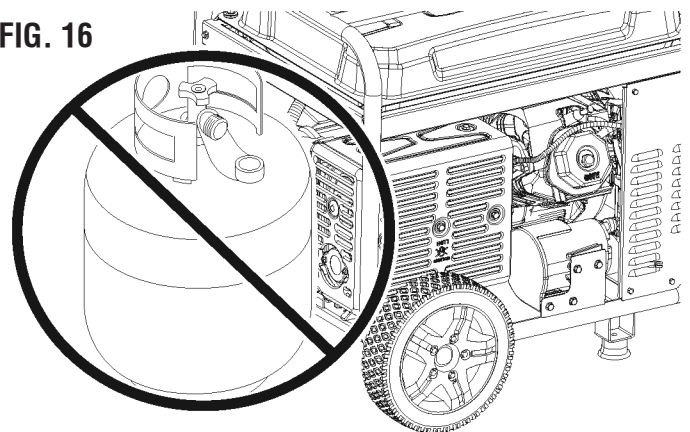

OPERATION

5. Hold the LPG/propane hose firmly and push the nipple into the cylinder valve.

6. Use your hand to thread the LPG/propane hose to the cylinder valve. **Do not cross-thread. Do not use tools or sealants.**

NOTE: There will be some resistance as the hose seals in the cylinder valve. To complete the connection, turn the connector an additional one-half to three-quarters of a turn. If unable to complete the connection, disconnect the hose and try again. If the connection still cannot be completed, **DO NOT** use this hose!

7. Connect the LPG/propane hose to the generator using the quick-connect collar.

- Pull back the quick-connect collar.
- Push the hose onto the propane inlet.
- Push the collar forward so that the hose is secured properly. Gently pull the hose to see that it is secure.

SELECTING THE FUEL SOURCE

See Figure 18.

⚠ DANGER Fire and explosion hazard. **DO NOT** add gasoline to the fuel tank or connect the LPG/propane hose to the generator while the generator is in operation.

NOTICE Do not overload the generator. Load capacities differ depending on the fuel source. Before switching fuel sources, be sure the generator can supply enough running (continuous) and peak (starting) watts for the connected items.

The fuel source can be switched while the engine is off or while it is running if a propane tank supply line is connected to the generator **BEFORE** operation.

To switch to gasoline:

1. Turn the fuel selector switch to **GASOLINE**.
2. Turn off the flow of propane gas.

To switch to propane:

1. Open the cylinder valve on the LP gas cylinder to start the flow of propane.
2. Turn the fuel selector switch to **LPG**.
3. Turn off the flow of gasoline.

FIG. 17

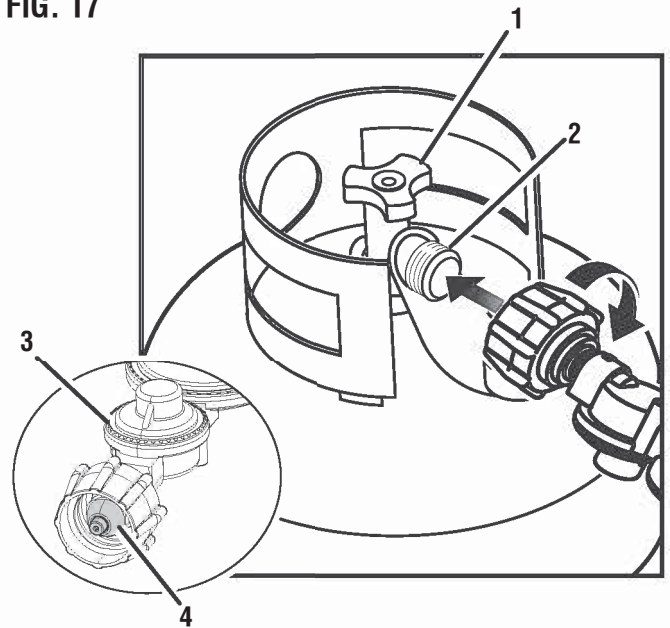

- 1 - Handwheel
- 2 - Cylinder Valve
- 3 - LPG/Propane Hose
- 4 - Beaded insert

FIG. 18

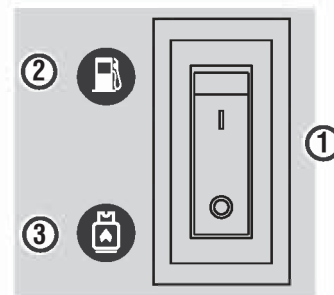

- 1 - Fuel Selector Switch
- 2 - Gasoline
- 3 - Propane

OPERATION

DATA CENTER

See Figure 19.

Push the mode button to cycle through the data display modes.

Voltage: Displays current voltage output.

Frequency (Hz): Displays power output frequency in Hertz.

Lifetime Hours: Displays the lifetime run hours.

Run Time/Maintenance: Displays current run time. Resets to zero when shut down. Maintenance reminder displayed when required.

Maintenance Codes:

P25 – Change engine oil

P50 – Clean air filter, Change engine oil

P100 – Change engine oil, clean air filter, replace fuel filter

PAIRING THE KEY FOB

See Figures 20 - 21

1. Bring the key fob in range of the generator.

2. Confirm that the battery is connected.

3. Press the battery switch to the ON position.

NOTE: When battery power is available, the battery indicator light will illuminate.

4. Press and hold the engine start/stop button for 15 seconds until the button flashes red and white, then release it.

5. Press and hold the start button on the key fob for one second, then release it.

- If the key fob paired successfully, the engine start/stop button will turn flash white 3 times.
- If pairing was unsuccessful, the LED around the engine start/stop button will continue flashing red and white. Wait several seconds, then make a second attempt. If the second attempt fails, turn the battery switch to the OFF position, wait several seconds and repeat the process. If subsequent attempts fail, turn the battery switch to the OFF position and contact customer service.

6. After the key fob is successfully paired to the generator, turn the battery switch to the ON position and press start on the key fob to confirm the pairing.

FIG. 19

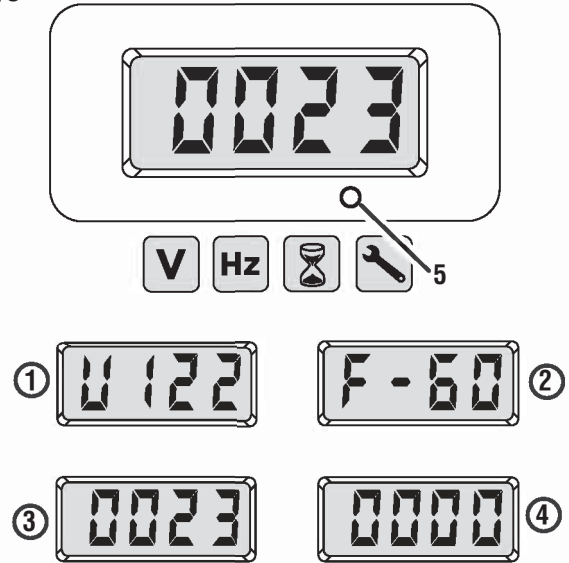

- 1 - Voltage
- 2 - Frequency
- 3 - Lifetime Hours
- 4 - Run Time/Maintenance Reminder
- 5 - Mode Button

FIG. 20

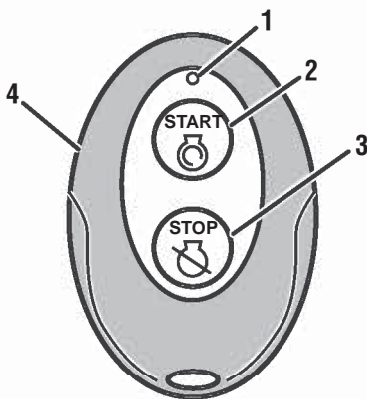

- 1 - Red LED
- 2 - Start Button
- 3 - Stop Button
- 4 - Key Fob

FIG. 21

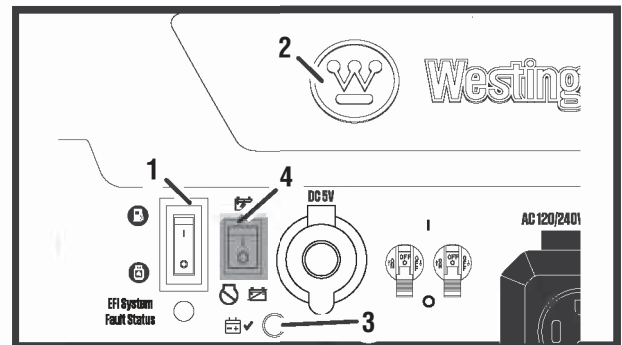

- 1 - Fuel Selector Switch
- 2 - Engine Start/Stop Button
- 3 - Battery Indicator
- 4 - Battery Switch

OPERATION

BREAK-IN PERIOD

For proper break-in, do not exceed 50% of the rated running watts during the first five hours of operation.

Use supplied oil until first recommend oil change. Do not use full synthetic oil during break in period. Full synthetic oil may prevent proper break-in and seating of the piston rings.

Vary the load occasionally to allow stator windings to heat and cool and help seat the piston rings.

- For gasoline, turn the fuel selector switch to **GASOLINE** and turn off the flow of propane gas.
- For propane, open the cylinder valve on the LP gas cylinder and turn off the flow of gasoline.
- Push the battery switch to the ON position.

NOTE: When battery power is available, the battery indicator light and the green LED around the engine start/stop button will illuminate.

BEFORE STARTING THE GENERATOR

Confirm that:

- The generator is placed in a safe, appropriate location.
- The generator is on a dry, flat, and level surface.
- Oil and fuel levels are within safe operating range.
- All loads are disconnected from the control panel receptacles.



Fire and explosion hazard. DO NOT move or tip the generator during operation.

STARTING THE GENERATOR

See Figures 21 - 23.

- Place the generator in a safe, appropriate location.
- Unplug all loads.
- Inspect oil and fuel levels. If needed add oil, refill the LP gas cylinder, add gasoline.
- Using the fuel selector switch, select **GASOLINE, PROPANE**.
- Start the flow of desired fuel and stop the flow from other fuel sources.

To start the generator using the recoil handle:

- Firmly grasp and pull the recoil handle slowly until there is increased resistance. At this point, pull the recoil handle rapidly away from the generator until the engine starts.

NOTE: Gently return the recoil handle into place after starting the unit. Do not let it snap back against the unit.

To start the generator using the remote start feature:

- Push and hold the start button on the key fob for two seconds.

NOTE: The red LED on the key fob should blink each time the start button is pressed. If the red LED does not blink and the generator does not start, then the battery in the fob may need to be replaced. If the red LED does blink but the generator does not start, the battery may need to charge. Please charge the battery with the charger.

To start the generator using the engine start/stop button:

- Push and hold the Engine START/STOP button for two seconds.

NOTE: If the Engine START/STOP button does not start the generator, the battery may need to charge. Please charge the battery with the charger.

To add loads after starting the generator:

- When the generator output stabilizes, connect loads to the control panel receptacles.

NOTE: Confirm that all devices are turned off before connecting them to the generator.

NOTE: Be sure that the wattage requirements for all connected devices are compatible with the capability of the generator.

- Connect and start the largest device or appliance.
- Allow the generator output to stabilize. Once stable, the engine should run smoothly, and the device should function properly.
- Connect and start the next largest device or appliance.
- Allow the generator output to stabilize.
- Repeat this process for each additional load.

OPERATION

FIG. 22

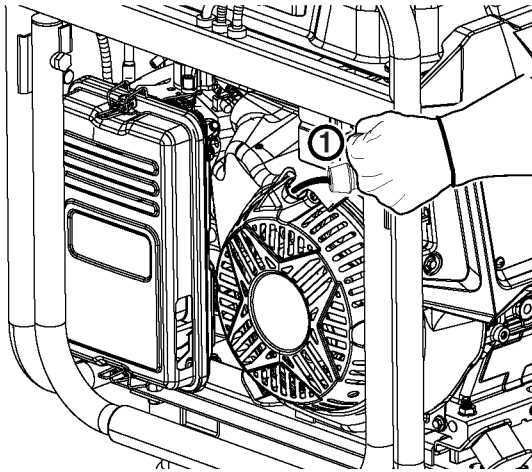

1 - Recoil Handle

FIG. 23

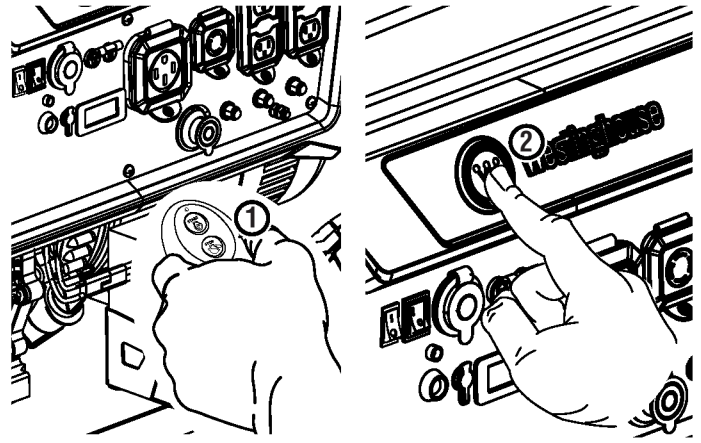

1 - Key Fob
2 - Engine Start/Stop Button

ELECTRONIC FUEL INJECTION OPERATIONS CHECK

- When the battery switch is turned on the Electronic Fuel injection will run a self test to ensure proper function. The EFI System Fault Status LED will illuminate for 2 seconds and then turn off indicating proper function.
- When the battery has a low charge, the unit will run multiple tests on the Electronic Fuel Injection System. Charge the battery to see if this corrects the issue. If the EFI System Fault Status LED continues to blink, discontinue use and have the generator inspected by a qualified technician.

STOPPING THE GENERATOR

See Figures 21 and 23.

1. Remove any connected loads from the control panel receptacles.
2. Allow the generator to run at “no load” to reduce and stabilize engine and alternator temperatures.
3. Press and hold the engine START/STOP button or the stop button on the key fob for one second to stop the generator.
4. Turn the battery switch off.
5. Stop the flow of fuel.
 - For gasoline, turn the fuel selector switch to **GASOLINE**.
 - For propane, close the cylinder valve on the LP gas cylinder.
6. Disconnect the propane hose from the LP gas cylinder and the generator.

To stop the unit quickly in an emergency:

- Press and hold the engine START/STOP button or the stop button on the key fob for one second to stop the generator.

OPERATION

CIRCUIT BREAKERS

See Figures 24 - 25.

The 20 amp circuit breaker protects devices and equipment connected to the 120V, 20 amp receptacles from electrical overload. The 30 amp circuit breaker protects devices and equipment connected to the 120V, 30 amp receptacles from electrical overload. The main circuit breaker will automatically switch OFF if the combined load of the receptacles exceeds the capacity. If a circuit breaker activates, turn off the connected device, remove it from the port or outlet, and reset the circuit breaker.

FIG. 24

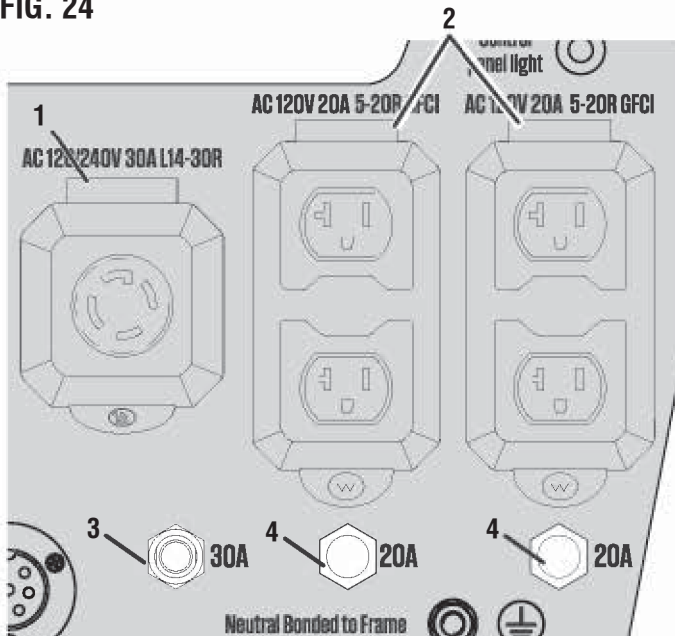

- 1 - 120/240 Volt AC 30 Amp Receptacle
- 2 - 120 Volt AC 20 Amp GFCI Receptacles
- 3 - 30 Amp Circuit Breaker
- 4 - 20 Amp Circuit Breakers

FIG. 25

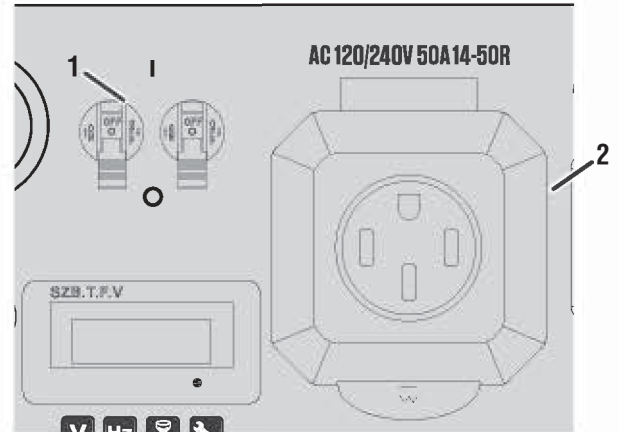

- 1 - Main Circuit Breaker
- 2 - 120/240 Volt AC 50 Amp Receptacle

TRANSPORTING

- Turn off the generator.
- Allow the generator to cool a minimum of 30 minutes before transporting.
- Replace all protective covers on the generator control panel.
- Always use the frame, not the handle, to lift the unit or attach any load restraints such as ropes or tie-down straps. DO NOT attempt to lift or secure the generator by holding onto any of its other components.
- Keep the unit level during transport to minimize the possibility of fuel leakage or, if possible, drain the fuel or run the engine until the fuel tank is empty before transport.



CAUTION

Fire hazard. DO NOT up-end the generator or place it on its side. Fuel or oil can leak and cause damage to the generator.

MAINTENANCE

WARNING ⚠ Accidental start-up. Disconnect the spark plug boot (see figure 28) from the spark plug when performing maintenance on the generator.

WARNING ⚠ Replace damaged or worn items with recommended or equivalent replacement parts. Using an incorrect or incompatible part might create a hazard that could result in serious personal injury.

WARNING ⚠ Allow hot components to cool for 30 minutes before performing any maintenance procedure.

WARNING ⚠ Avoid skin contact with engine oil or gasoline. Wear protective clothing and equipment. Wash all exposed skin with soap and water. Prolonged skin contact with gasoline or engine oil may cause severe skin irritation and other adverse reactions.

NOTICE Inspect the physical condition of the product prior to each use. Look for loose bolts, fluid leaks, and other signs of wear. Replace all damaged items. For replacement parts or assistance, contact our customer service team.

To prolong the life of this product, follow the care and maintenance instructions in this section. Contact customer service before servicing any recall or warranty parts.

CLEANING THE GENERATOR

Do not store or operate the generator in dirty, dusty, or corrosive environments. Do not allow foreign materials and debris to clog the vents on the unit.

NEVER clean the generator with a garden hose. Water can damage the fuel system and electrical components. If the unit needs to be cleaned, use a soft brush and damp cloth to clean the exterior and use low pressure air (no greater than 25 psi) to clean the vents.

Never use gasoline as a cleaning agent.

CLEANING/REPLACING THE AIR FILTER

See Figure 26.

Keep air filter clean. A dirty air filter can cause poor performance and decrease the service life of the product. **NEVER operate the generator without an air filter in place.**

1. Turn the generator off and allow the engine to cool for 30 minutes.
2. Unlock the latches and remove the cover.
3. Remove the air filter from the air cleaner housing and clean using compressed air. **Replace the air filter if damaged.**

NOTE: DO NOT submerge the filter in liquids or add oil.

NOTICE Do not pollute. Follow the guidelines of the EPA or other governmental agencies for proper disposal of hazardous materials. Consult local authorities or reclamation facility.

4. Install the air filter in the air cleaner housing and reinstall the air filter cover.

FIG. 26

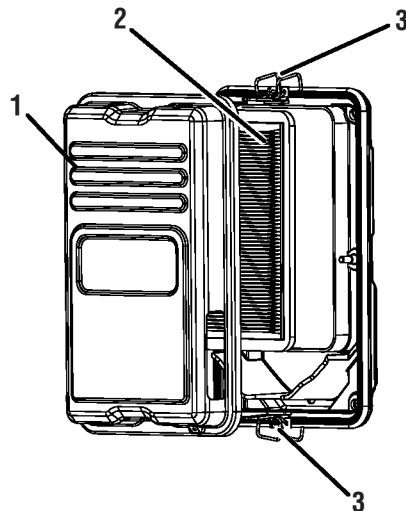

- 1 - Air Filter Cover
- 2 - Air Filter
- 3 - Latches

MAINTENANCE

CHANGING THE ENGINE OIL

See Figure 27.

For optimal performance, change the engine oil according to the figures specified in the **maintenance schedule**. When using the generator under extreme, dirty, dusty conditions or in extremely hot weather, change the oil more frequently.

NOTE: Change the oil while the engine is warm but not hot. Warm engine oil drains more quickly and thoroughly than cool lubricant. Contact with hot lubricant will cause serious burns.

1. Turn the generator off and allow the engine to cool for 30 minutes.
2. Place the generator on a level surface in a well-ventilated area.
3. Clean the area around the oil dipstick.
4. Slowly unscrew and remove the oil dipstick.
5. Place an oil pan (or suitable container) under the oil drain bolt.
6. Remove the oil drain bolt and allow the oil to drain.
7. After the oil has drained completely, replace the oil drain bolt.
8. Refill the oil as described in the *Operations* section.
9. Replace the oil dipstick and hand-tighten.
10. Clean any spilled oil.

CLEANING/REPLACING THE SPARK PLUG

See Figure 28.

NOTICE ALWAYS use compatible non-resistor-type spark plug. Use of resistor-type spark plug can result in rough idling, misfire, or may prevent the engine from starting.

Be sure the spark is clean and properly gapped. To clean or replace the spark plug:

1. Turn the generator off and allow the engine to cool for 30 minutes.
2. Place the generator on a level surface in a well-ventilated area.
3. Remove the spark plug boot by firmly pulling the spark boot directly away from the engine.
4. Clean the area around the spark plug.
5. Remove the spark plug with the spark plug socket wrench (included).

NOTICE Never apply any side load or move the spark plug laterally when removing the spark plug.

6. Inspect the spark plug. Replace if electrodes are pitted, burned, or the insulator is cracked. Only use a recommended replacement plug.
7. Measure the spark plug electrode gap with a wire-type feeler gauge. If necessary, correct the gap by carefully bending the side electrode.

Spark plug gap: 0.028 - 0.032 in. (0.70 - 0.80 mm)

8. Carefully install the spark plug finger tight, then tighten as additional 3/8 to 1/2 turn with the spark plug wrench.
9. Install the spark plug boot.

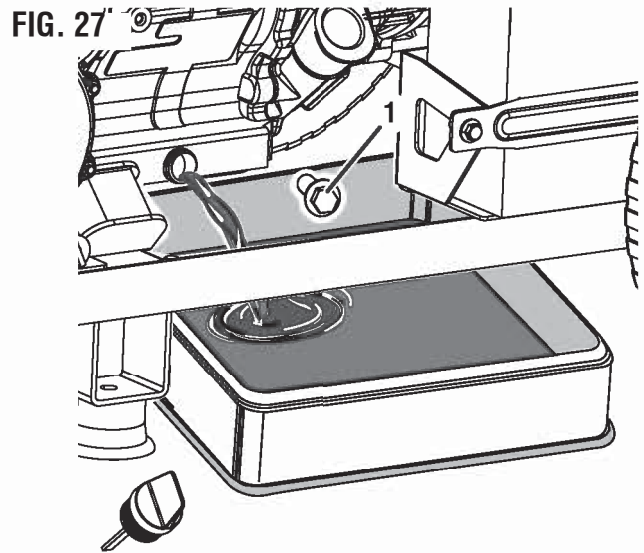

1 - Oil Drain Bolt

FIG. 28

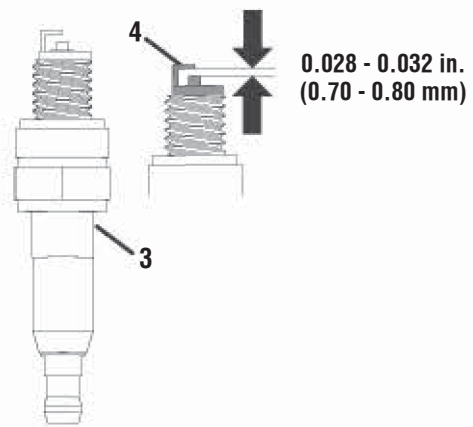
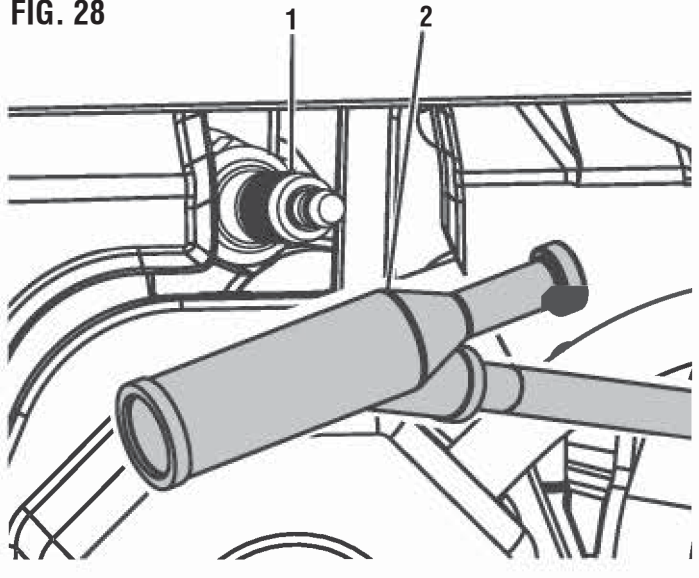

- 1 - Spark Plug
- 2 - Spark Plug Boot
- 3 - Insulator
- 4 - Electrode

MAINTENANCE

CLEANING THE SPARK ARRESTOR

See Figure 29.

Inspect and clean the spark arrestor according to the figures specified in the **maintenance schedule** or the engine manual (if applicable). Failure to clean the spark arrestor will result in degraded engine performance.

1. Turn the generator off and allow the engine to cool for 30 minutes.
2. Place the generator on a level surface in a well-ventilated area.
3. Remove the two screws securing the spark arrestor bracket.
4. Remove the bracket, screen, and spark arrestor from the generator.
5. Gently clean the screen and spark arrestor using a wire brush.
6. Reinstall the spark arrestor, screen, and bracket. Tighten screws securely.

DRAINING THE FUEL TANK AND INJECTOR

See Figure 30

WARNING ALWAYS store gasoline in a container approved for gasoline. Unapproved containers can break or deteriorate allowing gasoline or gasoline vapors to escape which can create a serious hazard.

Even properly stabilized fuel can leave residue and cause corrosion if left long term. If storing the generator for two to six months, drain the fuel to prevent gum and varnish buildup in the injector. If storing the generator for longer than six months, drain the fuel tank to prevent fuel separation, deterioration, and deposits in the fuel system.

- Turn the generator off and allow the engine to cool for 30 minutes.
- Place the generator on a level surface in a well-ventilated area.
- Disconnect the propane hose from the LP gas cylinder and the generator.

To drain the injector:

1. Start the generator.

NOTE: Remove the propane tank if installed and store in a safe location before starting engine.

2. After the engine starts, turn the fuel selection switch to the propane (**LPG**) position.
3. Allow the generator to run until the fuel in the injector is depleted and the engine stops.
4. Turn the engine control switch to the OFF (**O**) position.

To drain the fuel tank:

NOTE: When draining the fuel tank, be sure to drain the injector first before removing the remaining fuel from the fuel tank.

NOTICE To prevent damage to the unit, drain the engine oil before emptying the fuel tank. See **Changing the engine oil** for details.

1. Turn the fuel selector switch to the propane (**LPG**) position.
2. Clean area around fuel cap and remove the cap slowly.
3. Remove the fuel screen filter by slightly compressing it while removing it from the tank.
4. Using a commercially available gasoline hand pump (not included), siphon the gasoline from the fuel tank into an approved gasoline container. **DO NOT** use an electric pump.

FIG. 29

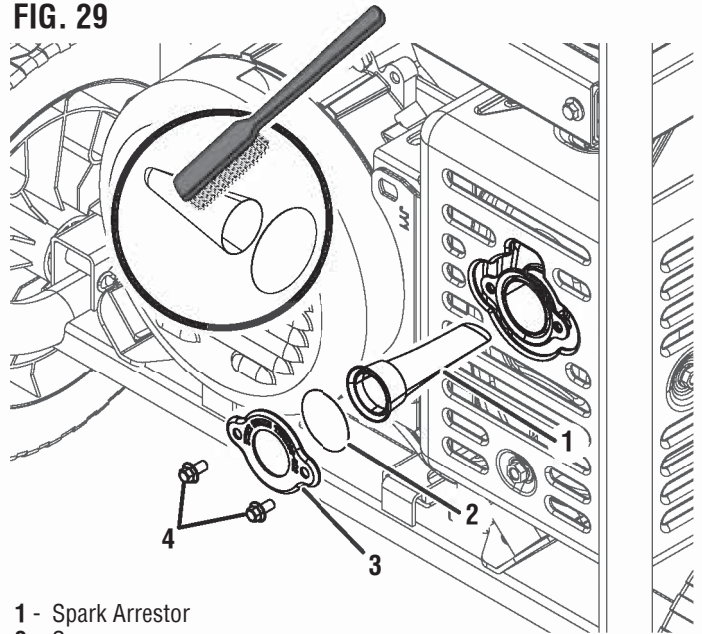

- 1 - Spark Arrestor
- 2 - Screen
- 3 - Bracket
- 4 - Screws

FIG. 30

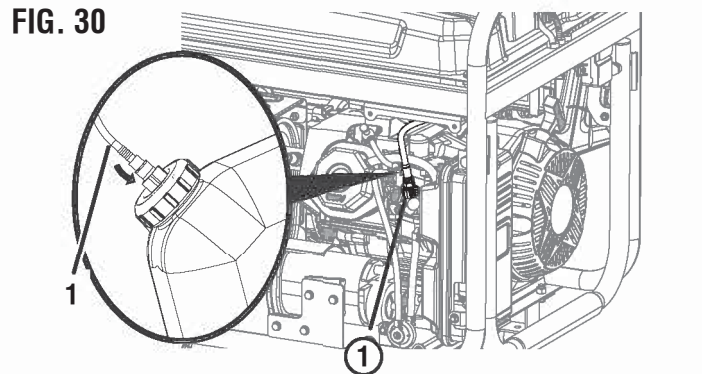

- 1 - Injector hose

MAINTENANCE

INSPECTING/ADJUSTING THE VALVE CLEARANCE

See Figures 31 - 32

NOTICE

Inspecting and adjusting valve clearance must be done when the engine is cold.

1. Turn the generator off and allow the engine to cool for 30 minutes.
2. Place the generator on a level surface in a well-ventilated area.
3. Remove the rocker arm cover and carefully remove the gasket. If the gasket is torn or damaged, it must be replaced.
4. Remove the spark plug so the engine can be rotated more easily.
5. Pull the recoil handle to rotate the engine to top dead center (TDC). Looking through the spark plug hole; the piston should be at the top (both valves are closed).
6. Both rocker arms should be loose at TDC on the compression stroke. If they are not, rotate the engine 360°.
7. Insert a feeler gauge between the rocker arm and the valve stem to measure valve clearance.

	Intake Valve	Exhaust Valve
Valve Clearance	0.0031 – 0.0047 in (0.08 – 0.12 mm)	0.0051 – 0.0067 in (0.13 – 0.17 mm)
Torque	8-12 Nm	8-12 Nm

8. If an adjustment is necessary, loosen the jam nut.
9. Slide the appropriate feeler gauge between the rocker arm and the valve stem.
10. Tighten the adjustment screw onto the push rod to obtain the specified clearance.

NOTE: The rocker arm should touch the feeler gauge.

11. Hold the adjustment screw in place and tighten the nut. **Torque: 106 inch-pound (12 Nm)**
12. Inspect valve clearance.
13. If no further adjustments are needed, perform this procedure on the other valve.
14. When finished, install the gasket, rocker arm cover, and spark plug.

FIG. 31

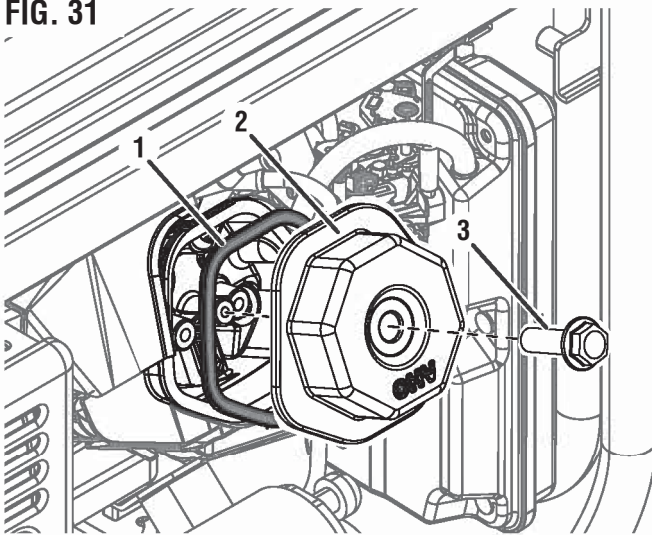

- 1 - Gasket
- 2 - Rocker Arm Cover
- 3 - Bolt

FIG. 32

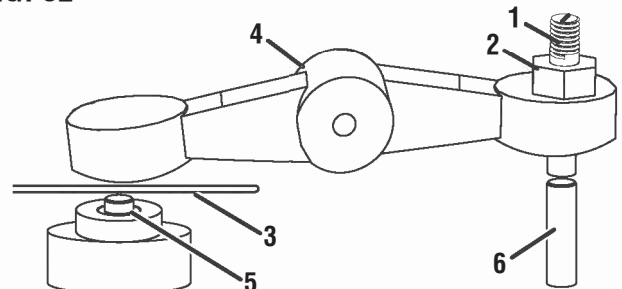

- 1 - Adjustment Screw
- 2 - Jam Nut
- 3 - Feeler Gauge
- 4 - Rocker Arm
- 5 - Valve Stem
- 6 - Push Rod

MAINTENANCE

BATTERY MAINTENANCE

See Figure 33.

WARNING The battery gives off explosive hydrogen gas during normal operation. A spark or flame can cause the battery to explode with enough force to cause serious injury or death. Wear protective clothing and a face shield, or have a skilled technician perform battery maintenance.

WARNING Burn hazard. The battery contains sulfuric acid (electrolyte) which is highly corrosive and poisonous. Wear protective clothing and eye protection when working near the battery. Keep children away from the battery.

WARNING NEVER smoke or work near sparks or other sources of ignition. NEVER touch both battery terminals at the same time with any body parts or any non-insulated tools. If battery acid contacts skin or clothing, flush immediately with water and neutralize with baking soda.

The battery shipped with the generator has been fully charged. A battery may lose some charge when not in use for prolonged periods of time.

NOTE: Once started, the generator will charge the battery after 30–60 minutes of use.

When the generator is not running, the included trickle charger can remain connected and will maintain the battery for an indefinite period of time. A red light on the charger indicates charging in progress. A green light indicates charging complete. Charge in a dry location.

1. Plug the charger into the battery charging port on the control panel.
2. Plug the wall receptacle end of the battery charger into a 120 Volt AC wall outlet.

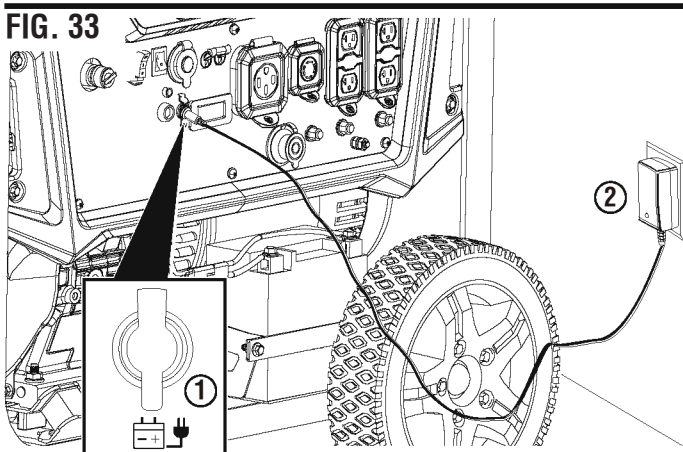

- 1 - Battery Charging Port
2 - Charger

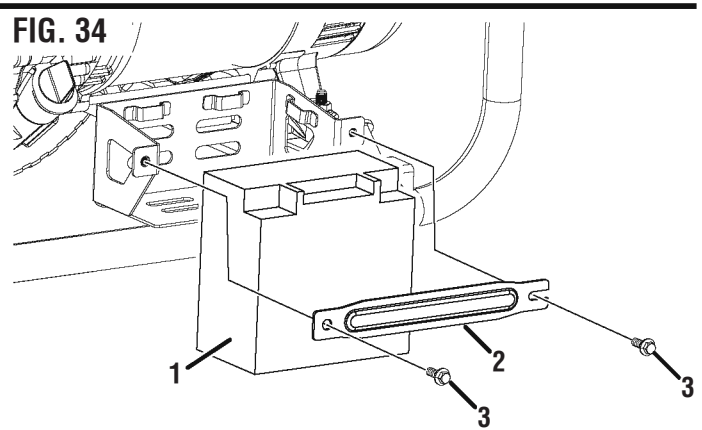

- 1 - Battery
2 - Battery Plate
3 - Bolt

BATTERY REPLACEMENT

See Figure 34.

CAUTION Battery posts, terminals contain lead and lead compounds. Wash hands after handling.

1. Remove the wheel in front of the battery.
2. Remove the two bolts and battery plate. Tilt the battery forward and remove.
3. Disconnect the negative (–) cable (black boot) from the negative (–) battery post.
4. Disconnect the positive (+) battery cable (red boot) from the positive (+) battery post.

NOTICE Always connect the cables in the following sequence to avoid possible shock.

5. On the replacement battery, connect the positive (+) battery cable (red boot) to the battery positive (+) terminal. Secure the boot over the battery post.
6. Connect the negative (–) battery cable (black boot) to the negative (–) positive terminal. Secure the boot over the battery post.
7. Install the battery in the battery tray. Install the battery plate and bolts. Tighten the bolts securely.
8. Reinstall the wheel.

MAINTENANCE

STORAGE

Turn the unit off and allow it to cool a minimum of 30 minutes before storage. Keep the unit upright. Do not store the generator on its side. Drain fuel before storing the unit. Store the unit and the fuel separately in well-ventilated areas away from sparks, open flames, pilot lights, heat, and other sources of ignition.

NOTICE

Gasoline stored for as little as 30 days can deteriorate, causing gum, varnish, and corrosive buildup in fuel lines, fuel passages, and the engine. This corrosive buildup restricts the flow of fuel, which can prevent the engine from starting after a prolonged storage period. The use of fuel stabilizer significantly increases the storage life of gasoline. Full-time use of fuel stabilizer is recommended. Follow the manufacturer's instructions for use.

STORAGE TIME	RECOMMENDED PROCEDURE
Less than 1 month	Clean the exterior of the generator and remove any debris from the muffler cooling vents.
2 to 6 months	Clean the exterior of the generator and remove any debris from the muffler cooling vents. Emptying fuel injector. (Store gasoline in an approved gasoline container or dispose of it according to state and local ordinances.)
6 months or longer	Clean the exterior of the generator and remove any debris from the muffler cooling vents. Emptying fuel injector and the fuel tank. (Store gasoline in an approved gasoline container or dispose of it according to state and local ordinances.) Put a tablespoon of engine oil into the spark plug cylinder. Gently pull the recoil handle to slowly turn the engine and distribute the lubricant. Reinstall the spark plug Change the engine oil.

MAINTENANCE SCHEDULE

Regular maintenance will improve performance and extend the service life of the generator. Follow the hourly or calendar intervals, whichever occurs first. More frequent service is required when operating in adverse conditions as noted below.

	Before Each Use	After First 25 Hours or First Month	Every 50 Hours or Every Six Months	Every 100 Hours or Every Six Months	Every 300 Hours or Every Year
Inspect Engine Oil	X				
Change Engine Oil ¹		X	X		
Clean Air Filter ²			X		
Inspect/Clean Spark Arrestor				X	
Inspect/Clean Spark Plug				X	
Inspect/Adjust Valve Clearance ³				X	
Replace Spark Plug					X
Replace Air Filter					X
Replace Fuel Valve				X	

¹ Change oil every month when operating under heavy load or in high temperatures.

² Clean more often under dirty or dusty conditions. Replace air filter if it cannot be adequately cleaned.

³ To avoid potential personal injury or damage to the unit, it is recommended that the maintenance task be performed at a Westinghouse approved service center (not covered by warranty).

MAINTENANCE

A partial list of maintenance parts is below. For replacement parts, please visit parts.wpowereq.com.

Air Filter	2275
Oil Drain Plug.....	91817
Drain Plug Assembly.....	50550011
Oil Dip Stick	260020-295
Spark Arrestor.....	1332
Carbon Brush.....	599019
Spark Plug	97132

 **WARNING** Do not use attachments or accessories that are not recommended for use with this product. Making unauthorized modifications and using incompatible accessories can damage the unit and void the warranty.

TROUBLESHOOTING

PROBLEM	POSSIBLE CAUSE	CORRECTION
Engine starts, then shuts down	Fuel level is low or depleted.	Add gasoline, connect propane cylinder.
	Low engine oil level stopped generator.	Fill oil to proper level and be sure the generator is on a flat, level surface.
	Dirty air filter.	Clean the air filter.
	Contaminated fuel source.	Drain gasoline and refill the fuel tank, replace the propane cylinder.
	Defective low oil level switch.	Contact customer service at 1 (855) 944-3571.
Engine lacks power	Air filter restricted.	Clean or replace air filter.
	Fuel system malfunction, ignition malfunction, or valves stuck.	Contact customer service at 1 (855) 944-3571.
Engine will not start	Fuel level is low or depleted.	Add gasoline, connect propane cylinder.
	Stale gasoline, generator stored without treating or draining gasoline, or refueled with bad gasoline.	Drain the gasoline tank. Refuel with fresh gasoline.
	Dirty air filter.	Clean the air filter.
	Low engine oil level stopped generator.	Fill oil to proper level and ensure the generator is on a flat, level surface.
	Spark plug wet with fuel (flooded engine).	Wait five minutes. Turn the fuel selector switch to the FUEL OFF position. Pull recoil handle rapidly several times. If the generator does not start, remove spark plug and dry.
	Spark plug faulty, fouled, or improperly gapped.	Gap or replace the spark plug. Reinstall.
	The fuel selector switch is in a wrong position.	Turn the fuel selector switch to the appropriate position.
	CO sensor removed or modified.	Return to original configuration.
	CO sensor activated or system fault occurred.	Relocate generator / Contact customer service at 1 (855) 944-3571.
Engine runs rough or bogs when load applied	Dirty air filter.	Clean the air filter.
	Generator overloaded.	Unplug some devices.
	Faulty power tool or appliance.	Replace or repair tool or appliance. Stop and restart the engine.
	Fuel system malfunction, ignition malfunction, or valves stuck.	Contact customer service at 1 (855) 944-3571.
No power at AC receptacles	AC circuit breaker/s tripped.	Inspect AC loads and reset circuit breaker/s.
	Faulty power tool or appliance.	Replace or repair tool or appliance. Stop and restart the engine.
	Faulty generator.	Contact customer service at 1 (855) 944-3571.

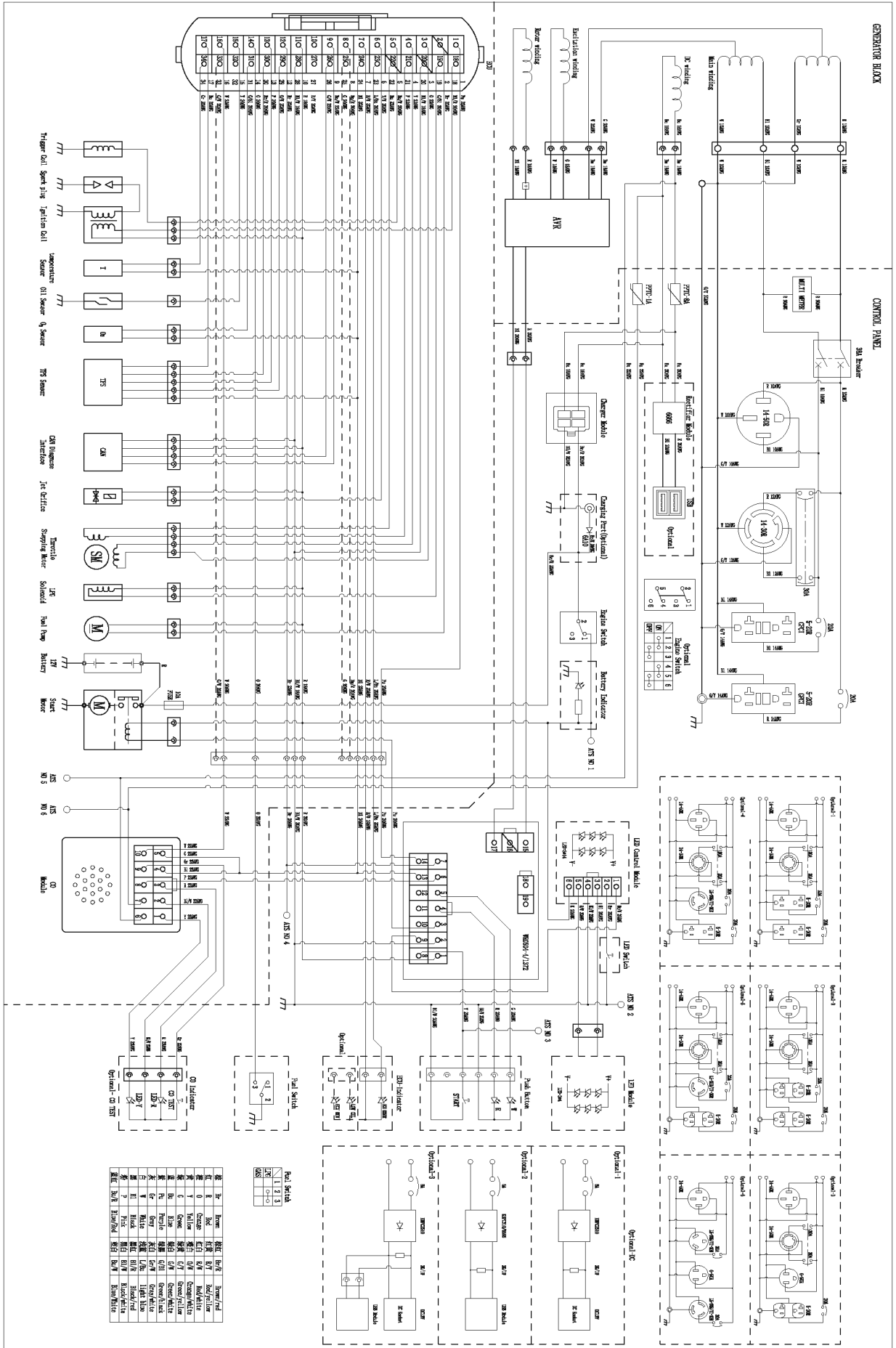



www.westinghouse.com

Service Hotline (855) 944-3571

777 Manor Park Drive, Columbus, OH 43228

Ⓜ and Westinghouse are trademarks of Westinghouse Electric Corporation.

Used under license by Westinghouse Outdoor Power Equipment.

© 2026 Westinghouse Outdoor Power Equipment, All Rights Reserved.