



## Harley-Davidson Street Glide, Electra Glide, Ultra and Limited models 2014-up\* / Road Glide 2015-up\*

\*Visit [MetraOnline.com](http://MetraOnline.com) for up-to-date vehicle specific applications.

### KIT FEATURES

- ISO DIN radio provision
- Included interface and LCD info screen
- ASWC-1 included, for retention of handlebar controls
- 44-UA20 antenna included

### KIT COMPONENTS

- A) Radio housing • B) Radio brackets • C) LCD screen • D) LCD back plate • E) (10) #8 x 3/8" Phillips screws • Axxess interface (not shown)

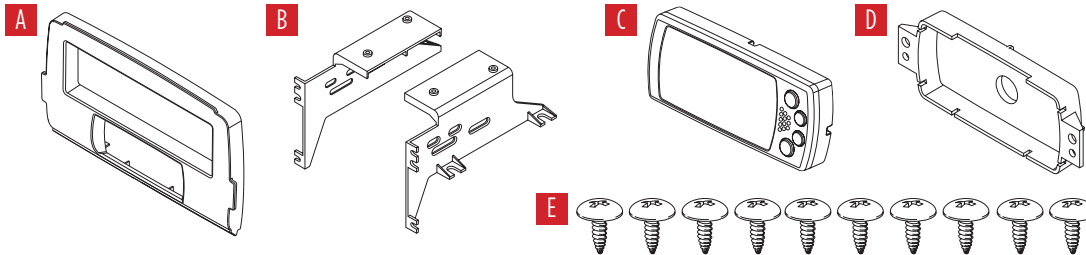

### TABLE OF CONTENTS

|  |      |
|--|------|
| Fairing Disassembly  |      |
| – Harley Davidson Street Glide, Electra Glide, Ultra, and Limited models 2014-up ..... | 2-3  |
| – Harley Davidson Road Glide 2015-up.....  | 4    |
| Kit Assembly .....   | 5    |
| Axxess interface installation.....   | 6-13 |

### WIRING & ANTENNA CONNECTIONS (sold separately)

- Wiring Harness: Axxess interface and harness included
- Antenna Adapter: 44-UA20 included
- Steering wheel control interface: • Included

### TOOLS REQUIRED

- Panel removal tool • Phillips screwdriver
- Torx screwdrivers • Allen wrenches

**CAUTION!** All accessories, switches, climate controls panels, and especially air bag indicator lights must be connected before cycling the ignition. Also, do not remove the factory radio with the key in the on position, or while the vehicle is running.

## DASH DISASSEMBLY

### Harley Davidson Street Glide, Electra Glide, Ultra, and Limited models 2014-up

1. Remove (4) T-27 from inner fairing. (Figure A)
2. Remove (3) T-27 from windshield (caution not to drop the outer fairing or windshield). (Figure B)
3. Remove outer fairing, unplugging the headlight. (Figure C)
4. Remove (2) T-27 to remove the fairing vent and remove the vent. (Figure D)

*Continued on next page*

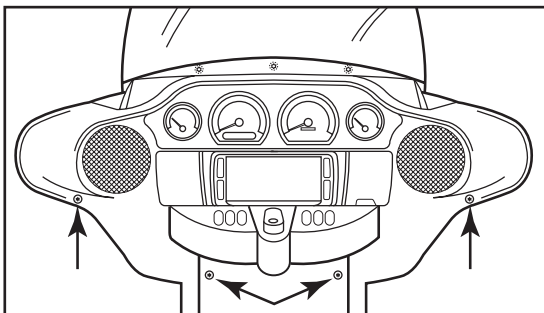

(Figure A)

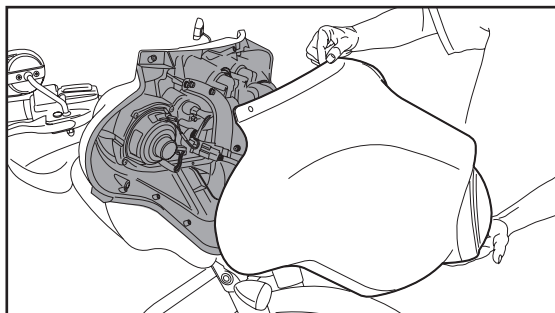

(Figure C)

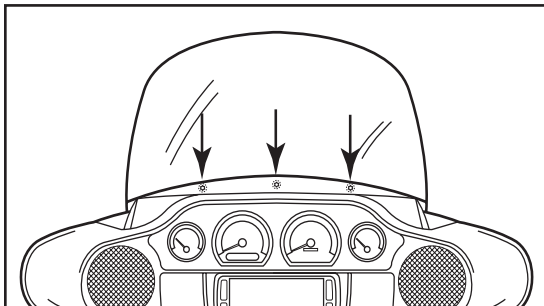

(Figure B)

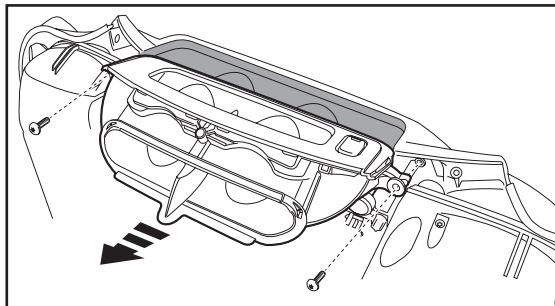

(Figure D)

## DASH DISASSEMBLY (CONT)

5. Remove (11) screws securing the radio bracket: (Figure E)
  - a. (2) T-27 Torx screws shared with the gauge cluster and a third T-27 Torx screw to remove the gauge cluster in step 7.
  - b. (4) 5/32" Allen screws facing outward.
  - c. (4) T-25 Torx screws secured to the radio.
  - d. (1) T-25 Torx screw shared with the storage pocket.
6. Remove the radio bracket. (Figure E)

**Note:** This bracket will be reused with the 99-9714 kit.
7. Remove the gauge cluster. (Figure E)
8. Remove (4) 3/16 Allen screws from the sides of radio. (Figure F)

**Note:** These screws will be reused with the 9714 kit.
9. Slide the radio out toward the rear of the bike, and unplug the radio. (Figure F)

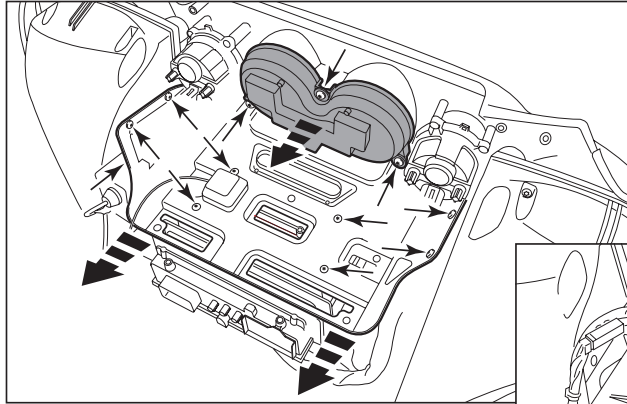

(Figure E)

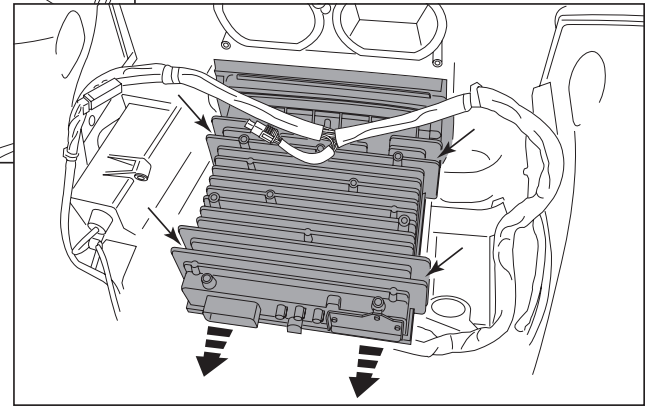

(Figure F)

## DASH DISASSEMBLY (CONT)

### Harley Road Glide 2015-up

1. Remove the lower torx screws on either side holding the wind deflector wings (only the lower two need to be removed). (Figure A)
2. Remove (1) 3/16 Allen screw securing each turn signal. (Figure B)
3. Remove (4) Phillips screws from the windshield and set the windshield aside. (Figure C)
4. Remove the top fairing trim clipped to the top of the radio. (Figure D)
5. Unplug the turn signals.
6. Remove the speaker grills with a panel removal tool and remove (1) torx screw from each side. (Figure E)

**CAUTION:** The fairing will be loose at this point. Have a helper hold it to keep from damaging it when removing the screws.

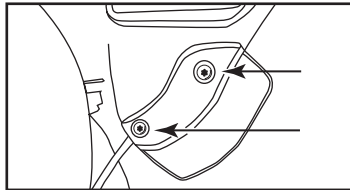

(Figure A)

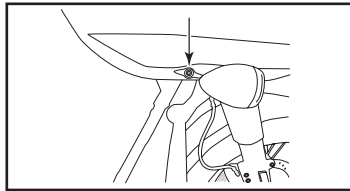

(Figure B)

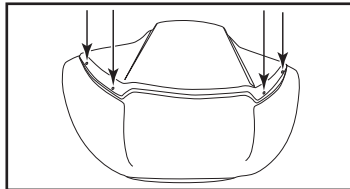

(Figure C)

7. Remove the fairing and set aside.
8. Remove (4) 3/16 Allen screws from the sides of the radio.

**Note:** These screws will be reused with the 9714 kit.

**CAUTION:** Be sure to hold the radio when removing the last screw so it will not drop.

9. Unplug and remove the radio.
10. Remove (2) Torx screws securing the fairing bracket attached to the radio.

**Note:** This bracket will be reused with the 99-9714 kit. Please note the orientation of the bracket. The curved portion faces the rear of the bike.

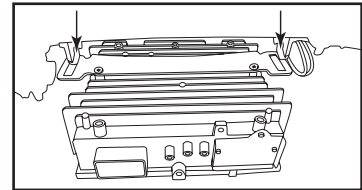

(Figure D)

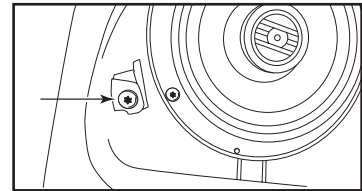

(Figure E)

## KIT ASSEMBLY

### ISO DIN radio provision

1. Secure the *radio brackets* to the *radio housing* with (4) #8 x 3/8" Phillips screws supplied. (Figure A)
2. Remove the metal "DIN" sleeve and trim ring from the aftermarket radio.
3. Slide the radio into the radio housing assembly and secure with screws supplied with the radio. (Figure B)
4. Insert the *LCD screen* into the radio housing, route the cable through the *LCD back plate*, and then secure to the radio housing assembly using (2) #8 x 3/8" screws supplied with the kit. (Figure C)
5. Secure the radio housing assembly to the bike using (4) 3/16 Allen screws previously removed in step 8 of disassembly. (Figure D)

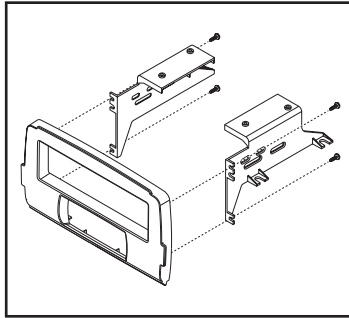

(Figure A)

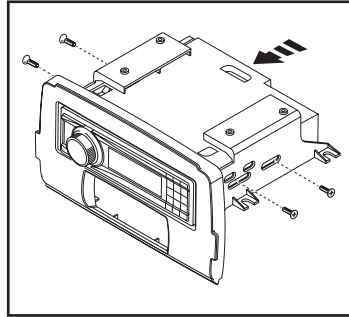

(Figure B)

6. **a. For the Street Glide, Electra Glide, Ultra, and Limited models 2014-up:** Attach the radio bracket removed in step 6 of disassembly to the top of the radio housing assembly, and secure with (4) Phillips screws supplied.
- b. For the Road Glide 2015-up:** Attach the fairing bracket removed in step 10 of disassembly to the top of the radio housing assembly, and secure with (2) Phillips screws supplied. Ensure the bracket is far forward, and the curved portion is facing the rear of the bike as mentioned in disassembly.

Continue to Axxess Interface Installation

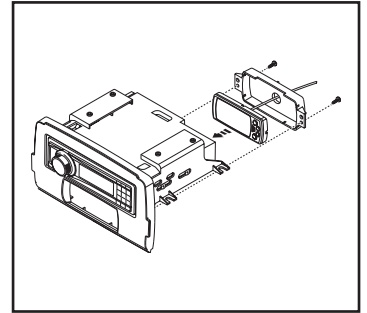

(Figure C)

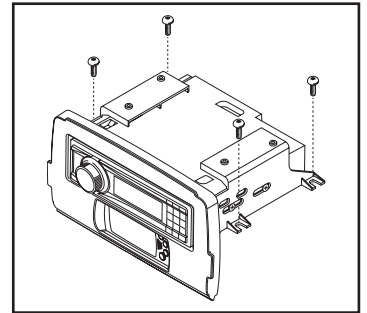

(Figure D)

# AXXESS INTERFACE INSTALLATION

## INTERFACE FEATURES

---

- Provides accessory power (12-volt 10-amp)
- High level speaker input
- Retains balance and fade
- Retains oil pressure and EITMS status
- ASWC-1 included, for retention of handlebar controls
- Micro “B” USB updatable

## INTERFACE COMPONENTS

---

- Axxess interface
- 99-9714 harness
- ASWC-1 Interface
- Female 3.5mm connector with Brown and Brown/White wires

## TABLE OF CONTENTS

---

|                                  |       |
|----------------------------------|-------|
| Wiring Instructions .....        | 7     |
| Installing the interface .....   | 8     |
| Initializing the interface ..... | 8-9   |
| Handlebar Control Settings.....  | 10-13 |
| Updating the 99-9714.....        | 14    |

## TOOLS REQUIRED

---

- Cutting tool • Crimping tool • Tape
- Connectors (example: butt-connectors, bell caps, etc.)

## WIRING INSTRUCTIONS

### From the 99-9714 harness to the aftermarket radio:

- Connect the **Black** wire to the ground wire.
- Connect the **Yellow** wire to the battery wire.
- Connect the **Red** wire to the accessory wire.
- Connect the **Orange** wire to the illumination wire. (If the aftermarket radio has no illumination wire, tape off the **Orange** wire).
- Connect the **White** wire to the left front positive speaker output.
- Connect the **White/Black** wire to the left front negative speaker output.
- Connect the **Gray** wire to the right front positive speaker output.
- Connect the **Gray/Black** wire to the right front negative speaker output.
- Connect the **Green** wire to the left rear positive speaker output.
- Connect the **Green/Black** wire to the left rear negative speaker output.
- Connect the **Purple** wire to the right rear positive speaker output.
- Connect the **Purple/Black** wire to the right rear negative output

### 12-pin pre-wired ASWC-1 harness:

This harness is to be used along with the ASWC-1 (provided) to retain handlebar audio controls. Please note that “handlebar control” is also referred to as “steering wheel control”.

- For the radios listed below, connect the included *female 3.5mm connector with stripped leads*, to the male 3.5mm SWC jack. Any remaining wires tape off and disregard:

- **Eclipse:** Connect the steering wheel control wire, normally **Brown**, to the **Brown/White** wire of the connector. Then connect the remaining steering wheel control wire, normally **Brown/White**, to the **Brown** wire of the connector.
- **Metra OE:** Connect the steering wheel control Key 1 wire (**Gray**) to the **Brown** wire.
- **Kenwood or select JVC with a steering wheel control wire:** Connect the **Blue/Yellow** wire to the **Brown** wire.

**Note:** If your **Kenwood** radio auto detects as a JVC, manually set the radio type to **Kenwood**. See the instructions under changing radio type.

- **XITE:** Connect the steering wheel control SWC-2 wire from the radio to the **Brown** wire.
- **Parrot Asteroid Smart or Tablet:** Connect the 3.5mm jack into the AX-SWC-PARROT (sold separately), and then connect the 4-pin connector from the AX-SWC-PARROT into the radio.

**Note:** The radio must be updated to rev. 2.1.4 or higher software.

- **Universal “2 or 3 wire” radio:** Connect the steering wheel control wire, referred to as Key-A or SWC-1, to the **Brown** wire of the connector. Then connect the remaining steering wheel control wire, referred to as Key-B or SWC-2, to the **Brown/White** wire of the connector. If the radio comes with a third wire for ground, disregard this wire.

**Note:** After the interface has been programmed to the vehicle, refer to the manual provided with the radio for assigning the SWC buttons. Contact the radio manufacturer for more information.

- **For all other radios:** Connect the 3.5mm jack into the jack on the aftermarket radio designated for an external steering wheel control interface. Please refer to the aftermarket radios manual if in doubt as to where the 3.5mm jack goes to.

## INSTALLING THE INTERFACE

It is highly advisable to read the following steps beforehand, to ensure a clear understanding of what is to be expected. The following steps must be done in the order that they are numbered.

### With the key in the off position:

1. Connect the 99-9714 harness into the interface, and then to the wiring harness in the vehicle.
2. Connect the LCD screen into the interface.
3. Connect the 44-UA20 (provided), and complete all necessary connections to the radio. Metra recommends using the proper mating adapter from Metra.
4. Do not connect the ASWC-1 just yet, leave it disconnected.

**Attention!** To prevent error codes, all electronic devices including the headlight and turn signals must be connected before proceeding to the next step.

## INITIALIZING THE INTERFACE

**Attention!** If the interface loses power for any reason, the following steps will need to be performed again.

1. Turn the key to the ignition position and wait until the radio comes on.  
**Note:** If the radio does not come on within 60 seconds, turn the key to the off position, disconnect the interface, check all connections, reconnect the interface, and then try again.
2. Program the LCD screen:
  - a. Pull the screen protector from the LCD screen.
  - b. Press and hold the “Return/ESC” button on the LCD screen for 5 seconds until “Select Interface” comes up.
  - c. Select “Connection Type”, and then press “Enter”
  - d. Scroll up or down to “Direct Connect”, and then press “Enter”
  - e. Once done, press “Return/ESC” to back out of that mode.
3. Test the radio and LCD screen for proper operation. Refer to “LCD Operation” for further information.
4. Turn the key to the off position.
5. Connect the ASWC-1 and then program it:
  - a. Turn the ignition on, the LED will start flashing rapidly.  
**Note:** If the LED did not start flashing rapidly, press the reset button for 3 seconds.

*Continued on the next page*

## INITIALIZING THE INTERFACE *(CONT)*

- b. Tap the Volume Up button on the handlebar at a moderate pace until the L.E.D. stops flashing rapidly.
  - c. After a few seconds the LED should stop flashing rapidly, and then go out for approximately 2 seconds.
  - d. After approximately 2 seconds there will be a series of 7 Green flashes, (6) short, and (1) long. The (1) long flash represents that the ASWC-1 detected the vehicle.  
**Tip:** *Knowing this will help to troubleshoot, if need be.*
  - e. The LED will pause for another 2 seconds, and then flash Red up to 17 times depending on which radio is connected to the interface. Refer to the L.E.D. feedback section for information.
  - f. This is the end of the auto detection stage. If the ASWC-1 detected the radio and vehicle successfully, the L.E.D. will light up solid.
  - g. Test the handlebar controls for proper operation. Refer to “Handlebar Control Settings” before proceeding onto the next step.
6. Turn the key to the off position.

## FINAL ASSEMBLY

1. Reassemble the fairing in reverse order of disassembly.

## LCD OPERATION

\* The included LCD screen provides oil pressure and EITMS status. For more information, please see the owner's manual that came with the bike.

### Main menu options:

- **Red** adjusts the red backlighting of the LCD (ranges from 1 to 32).
- **Blue** adjusts the blue backlighting of the LCD (ranges from 1 to 32).
- **Green** adjusts the green backlighting of the LCD (ranges from 1 to 32).
- **Contrast** adjusts the contrast of the LCD (ranges from 1 to 100).
- **Reset** puts the color back to the default settings.

▲ **Arrow Up** - Toggles “up” through menu options

▼ **Arrow Down** - Toggles “down” through menu options

↻ **Return/ESC** - Return to the previous menu

✓ **Enter** - Enter current menu option

## HANDLEBAR CONTROL SETTINGS

### L.E.D. Feedback

The (18) **Red** L.E.D. flashes represent which brand radio the ASWC-1 is connected to. Each flash represents a different radio manufacturer. For example, if you are installing a JVC radio, the ASWC-1 will flash Red (5) times, and then stop. Following is a legend that dictates which radio manufacturer corresponds to which flash.

### L.E.D. Feedback Legend

|                                |                                 |                                 |
|--------------------------------|---------------------------------|---------------------------------|
| 1 flash - Eclipse (Type 1) †   | 8 flashes - Visteon             | 12 flashes - Eclipse (Type 2) † |
| 2 flashes - Kenwood ‡          | 9 flashes - Valor               | 13 flashes - LG                 |
| 3 flashes - Clarion (Type 1) † | 10 flashes - Clarion (Type 2) † | 14 flashes - Parrot **          |
| 4 flashes - Sony / Dual        |                                 | 15 flashes - XITE               |
| 5 flashes - JVC                |                                 | 16 flashes - Philips            |
| 6 flashes - Pioneer / Jensen   |                                 | 17 flashes - TBD                |
| 7 flashes - Alpine *           | 11 flashes - Metra OE           | 18 flashes - JBL                |

\* **Note:** If the ASWC-1 flashes Red (7) times, and you do not have an Alpine radio connected to it, that means the ASWC-1 does not detect a radio connected to it. Verify that the 3.5mm jack is connected to the correct steering wheel jack/wire in the radio.

\*\* **Note:** The AX-SWC-PARROT is required (sold separately). Also, the Parrot radio must be updated to rev. 2.1.4 or higher through [www.parrot.com](http://www.parrot.com).

† **Note:** If you have a Clarion radio and the handlebar controls do not work, change the radio type to the other Clarion radio type; same for Eclipse. The following section explains how to do this.

‡ **Note:** If you have a Kenwood radio and the L.E.D. feedback comes back as showing as a JVC radio, change the radio type to a Kenwood. The following section explains how to do this.

## HANDLEBAR CONTROL SETTINGS (CONT)

**Attention:** The Axxess Updater App can also be used to program the following (3) sub-sections as well, pending that the interface has been initialized and programmed.

### Radio Type

If the L.E.D. flashes do not match the radio that is connected, change the radio type.

1. After (3) seconds of turning the key on, press and hold the Volume-Down button on the handlebar until the L.E.D. in the ASWC-1 goes solid.
2. Release the Volume-Down button; the L.E.D. will go out indicating we are now in Changing Radio Type mode.
3. Refer to the Radio Legend to know which radio number you would like to have programmed.
4. Press and hold the Volume-Up button until the L.E.D. goes solid, and then release. Repeat this step for the desired radio number.
5. Once the desired radio number has been selected, press and hold the Volume-Down button on the handlebar until the L.E.D. goes solid. The L.E.D. will remain on for about (3) seconds while it stores the new radio information.
6. Once the L.E.D. goes off, the Radio Type mode will then end. You can now test the handlebar controls.

**Note:** If at any time the user fails to press any button for a period longer than ten seconds, this process will abort.

### Radio Legend

|                      |                    |                       |               |
|----------------------|--------------------|-----------------------|---------------|
| 1 - Eclipse (Type 1) | 6 - Pioneer/Jensen | 10 - Clarion (Type 2) | 14 - Parrot   |
| 2 - Kenwood          | 7 - Alpine         | 11 - Metra OE         | 15 - XITE     |
| 3 - Clarion (Type 1) | 8 - Visteon        | 12 - Eclipse (Type 2) | 16 - Phillips |
| 4 - Sony / Dual      | 9 - Valor          | 13 - LG               | 17 - TBD      |
| 5 - JVC              |                    |                       | 18 - JBL      |

## HANDLEBAR CONTROL SETTINGS (CONT)

### Remap Buttons

The interface has the ability to change the button assignment for the handlebar control buttons, except Volume-Up and Volume-Down. Follow the steps below to remap the handlebar control buttons.

1. Within the first twenty seconds of turning the ignition on, press and hold the Volume-Up button on the handlebar until the L.E.D. goes solid.
2. Release the Volume-Up button, the L.E.D. will then go out; The Volume-Up button has now been programmed.
3. Follow the list in the Button Assignment Legend to reference the order in which the handlebar control buttons need to be programmed.

**Note:** *If the next function on the list is not present on the handlebar, press the Volume-Up button for (1) second until the L.E.D. comes on, and then release the Volume-Up button. This will tell the ASWC-1 that this function is not available, and it will move on to the next function.*

4. To complete the remapping process, press and hold the Volume-Up button on the handlebar until the L.E.D. in the ASWC-1 goes out.

### Button Assignment Legend

- |                    |                         |
|--------------------|-------------------------|
| 1 - Not allowed    | 10 - Band               |
| 2 - Not allowed    | 11 - Play/Enter         |
| 3 - Seek-Up/Next   | 12 - PTT (push to talk) |
| 4 - Seek-Down/Prev | 13 - On-Hook            |
| 5 - Mode           | 14 - Off-Hook           |
| 6 - Mute           | 15 - Fan-Up *           |
| 7 - Preset-Up      | 16 - Fan-Down *         |
| 8 - Preset-Down    | 17 - Temp-Up *          |
| 9 - Power          | 18 - Temp-Down *        |

**\* Not applicable in this application**

**Note:** *The aftermarket radio may not have all of these commands. Please refer to the manual provided with the radio, or contact the radio manufacturer, for specific commands recognized by that particular radio.*

## HANDLEBAR CONTROL SETTINGS (CONT)

### Dual Assignment (long button press)

The ASWC-1 has the capability to assign two functions to a single button, except Volume-Up and Volume-Down. Follow the steps below to program the button(s) to your liking.

**Note:** *Seek-Up and Seek-Down come programmed as Preset-Up and Preset-Down for a long button press.*

1. Turn on the ignition but do not start the vehicle.
2. Press and hold down the handlebar control button that you want to assign a long press function to, for ten seconds, or until the L.E.D. flashes rapidly. At this point release the button; the L.E.D. will then go solid.
3. Press and release the Volume-Up button the number of times corresponding to the new button number selected. Refer to the Dual Assignment Legend. The L.E.D. will flash rapidly while the Volume-Up button is being pressed, and then go back to a solid L.E.D. once released. Go to the next step once the Volume-Up button has been pressed the desired number of times.

**Caution:** *If more than ten seconds elapses between pressing the Volume-Up button, this process will abort, and the L.E.D. will go out.*

4. To store the long press button in memory, press the button that you assigned a long press button to (the button held down in Step 2). The L.E.D. will now go off indicating the new information has been stored.

**Note:** *These steps must be repeated for each button you would like to assign a dual purpose feature to. To reset a button back to its default state, repeat Step 1, and then press the Volume-Down button. The L.E.D. will go off, and the long press mapping for that button will be erased.*

### Dual assignment legend

- |                    |                  |
|--------------------|------------------|
| 1 - Not allowed    | 10 - Band        |
| 2 - Not allowed    | 11 - Play/Enter  |
| 3 - Seek-Up/Next   | 12 - PTT         |
| 4 - Seek-Down/Prev | 13 - On-Hook     |
| 5 - Mode/Source    | 14 - Off-Hook    |
| 6 - ATT/Mute       | 15 - Fan-Up      |
| 7 - Preset-Up      | 16 - Fan-Down *  |
| 8 - Preset-Down    | 17 - Temp-Up *   |
| 9 - Power          | 18 - Temp-Down * |

**\* Not applicable in this application**

## UPDATING THE 99-9714

- Download and install the Axxess Updater update from [axxessinterfaces.com](http://axxessinterfaces.com). Please follow the instructions on the website exactly as stated.
- Connect the USB-MINI-CAB update cable (sold separately) between the 99-9714 and the computer.
- From the Start Menu of the computer, click on on “All Programs”, and then “USBBootloader”.
- Press “Update Board”, the software will begin to download at this point.

**Note:** *Please note which firmware downloaded to the interface. This will help in troubleshooting, if need be.*

**Note:** *Both the interface AND display screen must be updated.*





**99-9714**  
INSTALLATION INSTRUCTIONS



**IMPORTANT**

*If you are having difficulties with the installation of this product, please call our Tech Support line at 1-800-253-TECH. Before doing so, look over the instructions a second time, and make sure the installation was performed exactly as the instructions are stated. Please have the vehicle apart and ready to perform troubleshooting steps before calling.*



**KNOWLEDGE IS POWER**

Enhance your installation and fabrication skills by enrolling in the most recognized and respected mobile electronics school in our industry. Log onto [www.installerinstitute.com](http://www.installerinstitute.com) or call 800-354-6782 for more information and take steps toward a better tomorrow.



**Metra recommends MECP  
certified technicians**