

The logo for Airecoler, featuring a stylized white 'A' with a blue wave-like element on the left, followed by the word 'Airecoler' in a white sans-serif font.

Airecoler

USER MANUAL

GT-XP9

Dear Valued Customer,

Welcome to the Airecoler family, where we're committed to delivering top-notch dehumidification solutions with exceptional customer support.

Whether you are dealing with excessive moisture, musty odors, or simply striving for a more pleasant living environment, our dehumidifier is here for help. This user manual and guide will ensure you understand Airecoler dehumidifier's functions and have access to ongoing support.

Post-Sales Support:

Our commitment to your satisfaction extends beyond the initial purchase. If you encounter any challenges or have questions regarding returns, damaged packages or replacements, our dedicated customer support team is ready to assist. Simply email us at service@airecoler.com with your purchase order ID, and we'll swiftly address your concerns.

Membership Perks:

Elevate your experience by registering as a member on Airecoler official website (www.airecoler.com) and unlock exclusive benefits, including priority customer support, special promotions and discounts, and valuable product updates and tips.

Best Regards,
The Airecoler Team

 **Website:** www.airecoler.com
 **Email:** service@airecoler.com

 **Phone:** [Available via our website](#)
 **Live Chat:** [Available via our website](#)

PRIOR TO FIRST USE

Please remove the dehumidifier from its packaging and allow it to stand upright for **24 hours** before plugging it in.

During normal shipping and handling, the dehumidifier may be positioned at various angles. Allowing the unit to stand upright for 24 hours helps ensure the compressor oil settles properly before operation, supporting optimal performance and long-term reliability. This waiting period is a standard recommendation for compressor-based appliances and helps ensure proper operation.

CONTENTS

WARNING for Using R32 Refrigerant	1
SAFETY PRECAUTIONS	8
PARTS IDENTIFICATION	9
INSTALLATION INSTRUCTIONS	10
1.Incorrect Installations.....	10
2.Recommended Installations.....	10
3. Position Your Dehumidifier.....	11
4. Set up the Drainage System.....	11
4.1 Drain by Internal Pump.....	11
4.2 Drain by Gravity.....	11
OPERATION INSTRUCTIONS	12
1. Plug in the Electrical Cord.....	12
2. Control Panel Instructions.....	12
2.1 The Control Buttons.....	12
2.2 The LCD Displays.....	13
3. Operate the Dehumidifier.....	13
3.1 Turn on the Dehumidifier.....	13
3.2 Check Room Humidity.....	13
3.3 Set Desired Humidity.....	13
3.4 Set Auto On/Off Timer.....	14
3.5 Turn the Dehumidifier off.....	14
4. Water Drainage.....	15
4.1 Drain by Internal Pump.....	15
4.2 Drain by Gravity.....	15
SMART FUNCTIONS	16
1. Compressor 3-Minute Delay.....	16
2. Auto Defrost.....	16
3. Auto-Restart.....	16
4. Temperature Protection Function.....	16
CARE & MAINTENANCE	17
1. Cleaning the Dehumidifier.....	17
2. Cleaning the Air Filter.....	17
3. Storage Guidelines.....	17
TROUBLESHOOTING TIPS	18
ERROR CODES AND SOLUTIONS	19
WARRANTY	20

WARNING for Using R32 Refrigerant

1. Safety Precautions

Read Safety Precautions Before Operation and Installation

Incorrect installation due to ignoring instructions can cause serious damage or injury.

WARNING

1). Installation (Space)

- That the installation of pipe-work shall be kept to a minimum.
- That pipe-work shall be protected from physical damage.
- Where refrigerant pipes shall be compliance with national gas regulations.
- That mechanical connections shall be accessible for maintenance purposes.
- In cases that require mechanical ventilation, ventilation openings shall be kept clear of obstruction.
- When disposing of the product is used, be based on national regulations, properly processed.

2). Servicing

- Any person who is involved with working on or breaking into a refrigerant circuit should hold a current valid certificate from an industry-accredited assessment authority, which authorizes their competence to handle refrigerants safely in accordance with an industry recognized assessment specification.

3). Maintenance and repair requiring the assistance of other skilled personnel shall be carried out under the supervision of the person competent in the use of flammable refrigerants.

4). Do not use means to accelerate the defrosting process or to clean, other than those recommended by the manufacturer.

5). The appliance shall be stored in a room without continuously operating ignition sources (for example: open flames, an operating gas appliance or an operating electric heater).

6). Be more careful that foreign matter (oil, water, etc) does not enter the piping. Also, when storing the piping, securely seal the opening by pinching, taping, etc.

7). Do not pierce or burn.

8). Be aware that refrigerants may not contain an odour.

9). All working procedure that affects safety means shall only be carried by competent persons.

10). Appliance shall be stored in a well-ventilated area where the room size corresponds to the room area as specific for operation.

11). The appliance shall be stored so as to prevent mechanical damage from occurring.

12). Joints shall be tested with detection equipment with a capability of 5 g/year of refrigerant or better, with the equipment in standstill and under operation or under a pressure of at least these standstill or operation conditions after installation. Detachable joints shall **NOT** be used in the indoor side of the unit (brazed, welded joint could be used).

13). When a FLAMMABLE REFRIGERANT is used, the requirements for installation space of appliance and /or ventilation requirements are determined according to

- the mass charge amount (M) used in the appliance,
- the installation location,

--the type of ventilation of the location or of the appliance.

2. Information servicing

1) Checks to the area

Prior to beginning work on systems containing flammable refrigerants, safety checks are necessary to ensure that the risk of ignition is minimized. For repair to the refrigerating system, the following precautions shall be complied with prior to conducting work on the system.

2) Work procedure

Works shall be undertaken under a controlled procedure so as to minimize the risk of a flammable gas or vapour being present while the work is being performed.

Technical personnel in charge of operation, supervision, maintenance of air-conditioning systems shall be adequately instructed and competent with respect to their tasks.

Works shall be undertaken with appropriate tools only (In case of uncertainty, please consult the manufacturer of the tools for use with flammable refrigerants).

3) General work area

All maintenance staff and others working in the local area shall be instructed on the nature of work being carried out. Work in confined spaces shall be avoided. The area around the work space shall be sectioned off. Ensure that the conditions within the area have been made safe by control of flammable material.

4) Checking for presence of refrigerant

The area shall be checked with an appropriate refrigerant detector prior to and during work, to ensure the technician is aware of potentially toxic or flammable atmospheres. Ensure that the leak detection equipment being used is suitable for use with all applicable refrigerants, i.e. non-sparking, adequately sealed or intrinsically safe.

5) Presence of fire extinguisher

If any hot work is to be conducted on the refrigerating equipment or any associated parts, appropriate fire extinguishing equipment shall be available to hand. Have a dry powder or CO₂ fire extinguisher adjacent to the charging area.

6) No ignition sources

No person carrying out work in relation to a REFRIGERATING SYSTEM which involves exposing any pipe work shall use any sources of ignition in such a manner that it may lead to the risk of fire or explosion. All possible ignition sources, including cigarette smoking, should be kept sufficiently far away from the site of installation, repairing, removing and disposal, during which refrigerant can possibly be released to the surrounding space. Prior to work taking place, the area around the equipment is to be surveyed to make sure that there are no flammable hazards or ignition risks. "No Smoking" signs shall be displayed.

7) Ventilated area

Ensure that the area is in the open or that it is adequately ventilated before breaking into the

system or conducting any hot work. A degree of ventilation shall continue during the period that the work is carried out. The ventilation should safely disperse any released refrigerant and preferably expel it externally into the atmosphere.

8) Check to the refrigerating equipment

Where electrical components are being changed, they shall befit for the purpose and to the correct specification. At all times the manufacturer's maintenance and service guidelines shall be followed. If in doubt, consult the manufacturer's technical department for assistance.

The following checks shall be applied to installations using flammable refrigerants:

- the charge size is in accordance with the room size within which the refrigerant containing parts are installed;
- the ventilation machinery and outlets are operating adequately and are not obstructed;
- if an indirect refrigerating circuit is being used, the secondary circuit shall be checked for the presence of refrigerant; marking to the equipment continues to be visible and legible.
- markings and signs that are illegible shall be corrected;
- refrigerating pipe or components are installed in a position where they are unlikely to be exposed to any substance which may corrode refrigerant containing components, unless the components are constructed of materials which are inherently resistant to being corroded or are suitably protected against being so corroded.

9) Checks to electrical devices

Repair and maintenance to electrical components shall include initial safety checks and component inspection procedures. If a fault exists that could compromise safety, then no electrical supply shall be connected to the circuit until it is satisfactorily dealt with. If the fault cannot be corrected immediately but it is necessary to continue operation, an adequate temporary solution shall be used. This shall be reported to the owner of the equipment so all parties are advised.

Initial safety checks shall include:

- that capacitors are discharged: this shall be done in a safe manner to avoid possibility of sparking;
- that no live electrical components and wiring are exposed while charging, recovering or purging the system;
- that there is continuity of earth bonding.

10) Repairs to sealed components

a. During repairs to sealed components, all electrical supplies shall be disconnected from the equipment being worked upon prior to any removal of sealed covers, etc. If it is absolutely necessary to have an electrical supply to equipment during servicing, then a permanently operating form of leak detection shall be located at the most critical point to warn of a potentially hazardous situation.

b. Particular attention shall be paid to the following to ensure that by working on electrical components, the casing is not altered in such a way that the level of protection is affected. This shall include damage to cables, excessive number of connections, terminals not made to

original specification, damage to seals, incorrect fitting of glands, etc.

- Ensure that apparatus is mounted securely.
- Ensure that seals or sealing materials have not degraded such that they no longer serve the purpose of preventing the ingress of flammable atmospheres. Replacement parts shall be in accordance with the manufacturer's specifications.

NOTE: The use of silicon sealant may inhibit the effectiveness of some types of leak detection equipment. Intrinsically safe components do not have to be isolated prior to working on them.

11) Repairs to intrinsically safe components

Do not apply any permanent inductive or capacitance loads to the circuit without ensuring that this will not exceed the permissible voltage and current permitted for the equipment in use. Intrinsically safe components are the only types that can be worked on while live in the presence of a flammable atmosphere. The test apparatus shall be the correct rating.

Replace components only with parts specified by the manufacturer. Other parts may result in the ignition of refrigerant in the atmosphere from a leak.

12) Cabling

Check that cabling will not be subject to wear, corrosion, excessive pressure, vibration, sharp edges or any other adverse environmental effects. The check shall also take into account the effects of aging or continual vibration from sources such as compressors or fans.

13) Detection of flammable refrigerants

Under no circumstances shall potential sources of ignition be used in the searching for or detection of refrigerant leaks. A halide torch (or any other detector using a naked flame) shall not be used.

14) Leak detection methods

The following leak detection methods are deemed acceptable for systems containing flammable refrigerants. Electronic leak detectors shall be used to detect flammable refrigerants, but the sensitivity may not be adequate, or may need re-calibration. (Detection equipment shall be calibrated in a refrigerant-free area.) Ensure that the detector is not a potential source of ignition and is suitable for the refrigerant. Leak detection equipment shall be set at a percentage of the LFL of the refrigerant and shall be calibrated to the refrigerant employed and the appropriate percentage of gas (25% maximum) is confirmed. Leak detection fluids are suitable for use with most refrigerants but the use of detergents containing chlorine shall be avoided as the chlorine may react with the refrigerant and corrode the copper pipe-work.

If a leak is suspected, all naked flames shall be removed or extinguished. If a leakage of refrigerant is found which requires brazing, all of the refrigerant shall be recovered from the system, or isolated (by means of shut off valves) in a part of the system remote from the leak. For appliances containing FLAMMABLE REFRIGERANTS, oxygen free nitrogen (OFN) shall then be purged through the system both before and during the brazing process.

15) Removal and evacuation

When breaking into the refrigerant circuit to make repairs - or for any other purpose-

conventional procedures shall be used, However, for FLAMMABLE REFRIGERANTS it is important that best practice is followed since flammability is a consideration. Opening of the refrigerant systems shall not be done by brazing. The following procedure shall be adhered to:

- remove refrigerant;
- purge the circuit with inert gas;
- evacuate;
- purge again with inert gas;
- open the circuit by cutting or brazing

The refrigerant charge shall be recovered into the correct recovery cylinders. For appliances containing FLAMMABLE REFRIGERANTS, the system shall be “flushed” with OFN to render the unit safe. This process may need to be repeated several times. Compressed air or oxygen shall not be used for pouring refrigerant systems.

For appliances containing FLAMMABLE REFRIGERANTS, flushing shall be achieved by breaking the vacuum in the system with OFN and continuing to fill until the working pressure is achieved, then venting to atmosphere, and finally pulling down to a vacuum. This process shall be repeated until no refrigerant is within the system. When the final OFN charge is used, the system shall be vented down to atmospheric pressure to enable work to take place. This operation is absolutely vital if brazing operations on the pipe-work are to take place.

Ensure that the outlet for the vacuum pump is not closed to any ignition sources and there is ventilation available.

16) Charging procedures

In addition to conventional charging procedures, the following requirements shall be followed.

- Works shall be undertaken with appropriate tools only (In case of uncertainty, please consult the manufacturer of the tools for use with flammable refrigerants).
- Ensure that contamination of different refrigerants does not occur when using charging equipment. Hoses or lines shall be as short as possible to minimize the amount of refrigerant contained in them.
- Cylinders shall be kept upright.
- Ensure that the refrigeration system is earthed prior to charging the system with refrigerant.
- Label the system when charging is complete (if not already).
- Extreme care shall be taken not to overfill the refrigeration system.
- Prior to recharging the system it shall be pressure tested with OFN. The system shall be leak tested on completion of charging but prior to commissioning. A follow up leak test shall be carried out prior to leaving the site.

17) Decommissioning

Before carrying out this procedure, it is essential that the technician is completely familiar with the equipment and all its details. It is recommended good practice that all refrigerants are

recovered safely or safely vented (For R290 refrigerant models). Prior to the task being carried out, an oil and refrigerant sample shall be taken.

In case analysis is required prior to re-use of reclaimed refrigerant. It is essential that electrical power is available before the task is commenced.

a) Become familiar with the equipment and its operation.

b) Isolate system electrically.

c) Before attempting the procedure, ensure that:

- Mechanical handling equipment is available, if required, for handling refrigerant cylinders;
- All personal protective equipment is available and being used correctly;
- The recovery process is supervised at all times by a competent person;
- Recovery equipment and cylinders conform to the appropriate standards.

d) Pump down refrigerant system, if possible.

e) If a vacuum is not possible, make a manifold so that refrigerant can be removed from various parts of the system.

f) Make sure that cylinder is situated on the scales before recovery takes place.

g) Start the recovery machine and operate in accordance with instructions.

h) Do not overfill cylinders. (No more than 70% liquid volume. The liquid density of the refrigerant with a reference temperature of 50°C).

i) Do not exceed the maximum working pressure of the cylinder, even temporarily.

j) When the cylinders have been filled correctly and the process completed, make sure that the cylinders and the equipment are removed from site promptly and all isolation valves on the equipment are closed off.

k) Recovered refrigerant shall not be charged into another refrigeration system unless it has been cleaned and checked.

18) Labeling

Equipment shall be labeled stating that it has been de-commissioned and emptied of refrigerant. The label shall be dated and signed. Ensure that there are labels on the equipment stating the equipment contains flammable refrigerant.

19) Recovery

When removing refrigerant from a system, either for service or decommissioning, it is recommended good practice that all refrigerants are removed safely.

When transferring refrigerant into cylinders, ensure that only appropriate refrigerant recovery cylinders are employed. Ensure that the correct numbers of cylinders for holding the total system charge are available. All cylinders to be used are designated for the recovered refrigerant and labeled for that refrigerant (i.e special cylinders for the recovery of refrigerant). Cylinders shall be complete with pressure relief valve and associated shut-off valves in good working order.

Empty recovery cylinders are evacuated and, if possible, cooled before recovery occurs. The recovery equipment shall be in good working order with a set of instructions concerning the

equipment that is at hand and shall be suitable for the recovery of flammable refrigerants. In addition, a set of calibrated weighing scales shall be available and in good working order.

Hoses shall be complete with leak-free disconnect couplings and in good condition. Before using the recovery machine, check that it is in satisfactory working order, has been properly maintained and that any associated electrical components are sealed to prevent ignition in the event of a refrigerant release. Consult manufacturer if in doubt.

The recovered refrigerant shall be returned to the refrigerant supplier in the correct recovery cylinder, and the relevant Waste Transfer Note arranged. Do not mix refrigerants in recovery units and especially not in cylinders.

If compressors or compressor oils are to be removed, ensure that they have been evacuated to an acceptable level to make certain that flammable refrigerant does not remain within the lubricant. The evacuation process shall be carried out prior to returning the compressor to the suppliers. Only electric heating to the compressor body shall be employed to accelerate this process. When oil is drained from a system, it shall be carried out safely.

20) Transportation, marking and storage for units

a. Transport of equipment containing flammable refrigerants

Compliance with the transport regulations

b. Marking of equipment using signs

Compliance with local regulations

c. Disposal of equipment using flammable refrigerants

Compliance with national regulations

d. Storage of equipment/appliances

The storage of equipment should be in accordance with the manufacturer's instructions.

e. Storage of packed (unsold) equipment

Storage package protection should be constructed such that mechanical damage to the equipment inside the package will not cause a leak of the refrigerant charge.

The maximum number of pieces of equipment permitted to be stored together will be determined by local regulations.

SAFETY PRECAUTIONS

- Place the dehumidifier on a flat surface to minimize vibration and noise.
- Before use, check the power cord for any damage. Do not operate the dehumidifier if the power cord or plug is damaged.
- Insert the three-prong plug into a matching electrically grounded outlet (120V/60Hz, at least 10A). Do not cut off the third prong or modify the power cord length.
- Avoid operating the dehumidifier in standing water and ensure the motor and wiring stay dry.
- Never immerse the dehumidifier in water or other liquids.
- Keep the dehumidifier away from heat-generating devices, flammable materials, or hazardous substances.
- Turn off and unplug the power supply before cleaning or storing the dehumidifier.
- Always grasp the plug (not the cord) to unplug.
- Do not insert fingers or other objects into the air inlet or outlet.
- Avoid sitting, standing, or placing heavy objects on the dehumidifiers.
- Disconnect the power if you notice strange sounds, odors, or smoke coming from the dehumidifier.
- Do not operate or turn off the dehumidifier by plugging in or unplugging it. Use the control panel instead.
- This dehumidifier should only be used by adults who have read the manual and understand its operation.
- This dehumidifier is not intended for use by individuals (including children) with reduced physical, sensory or mental capabilities, unless supervised or instructed by someone responsible for their safety.
- Children should be supervised to ensure that they do not play with the dehumidifier.
- Do not tilt the dehumidifier while it is operating to prevent water overflow.

PARTS IDENTIFICATION

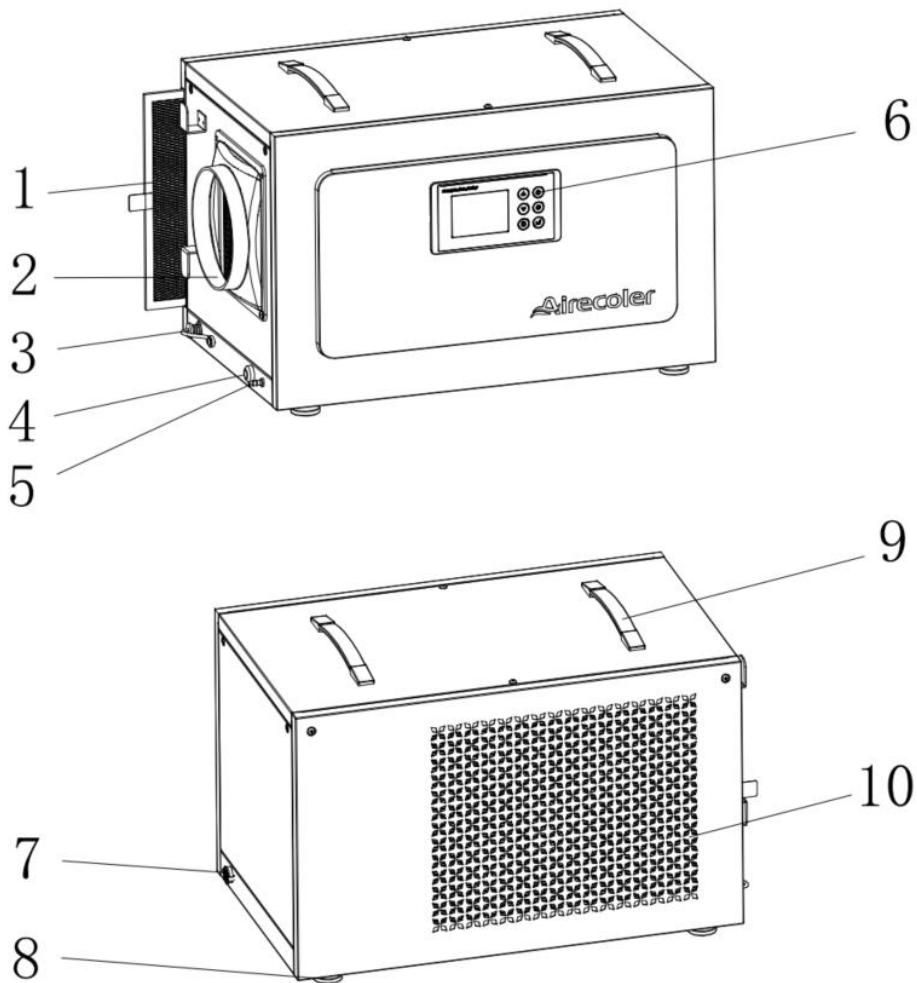

- | | |
|-------------------------|------------------------|
| 1. Filter | 6. Control Panel |
| 2. Air Outlet | 7. Remote Control Port |
| 3. Gravity Drain Outlet | 8. Foot |
| 4. Power Cord Port | 9. Handle |
| 5. Pump Drain Outlet | 10. Air Inlet |

NOTE: DO NOT OBSTRUCT THE AIR INLET OR OUTLET.

INSTALLATION INSTRUCTIONS

1. Incorrect Installations

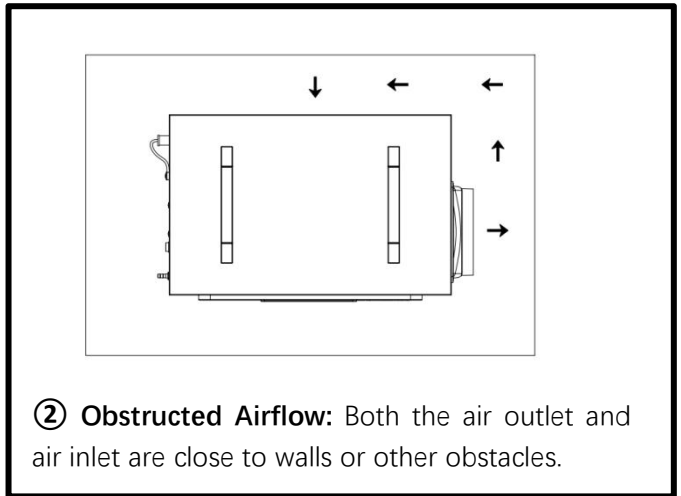
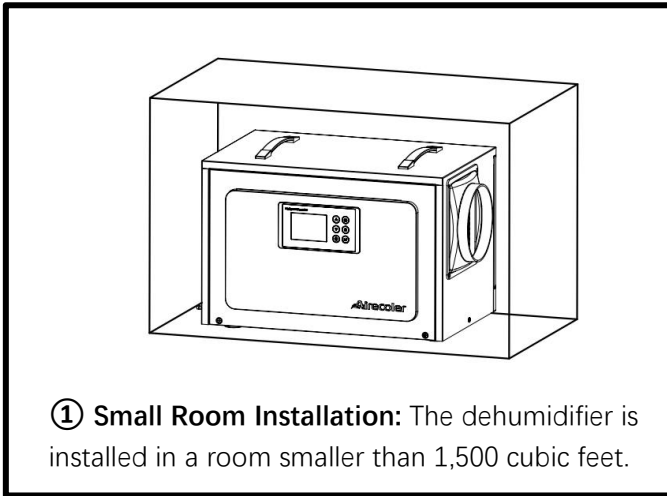

In either of the above 2 situations, the dry, hot air discharged by the dehumidifier would be quickly drawn back into the unit. This can interfere with the humidity sensor, leading to inaccurate or fluctuating humidity readings. As a result, the dehumidifier may cycle on and off frequently or may not operate properly.

Note: If the dehumidifier needs to be installed in a small space, set the target humidity level to 10. This will help the dehumidifier run continuously to ensure its effectiveness, regardless of the inlet humidity reading.

2. Recommended Installations

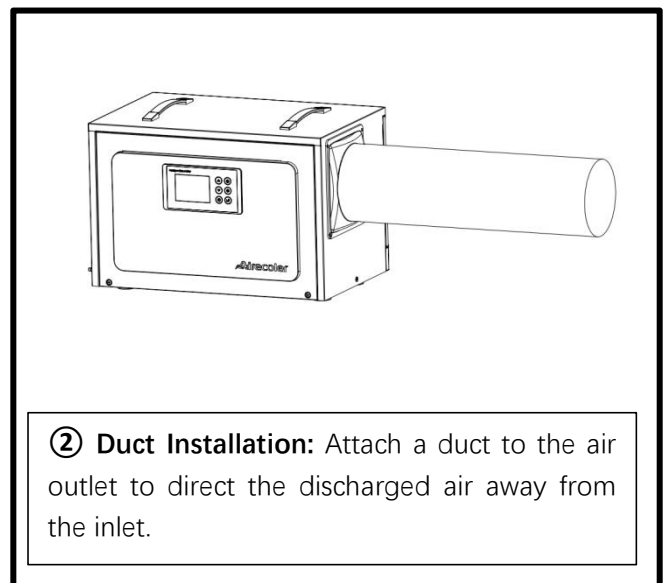
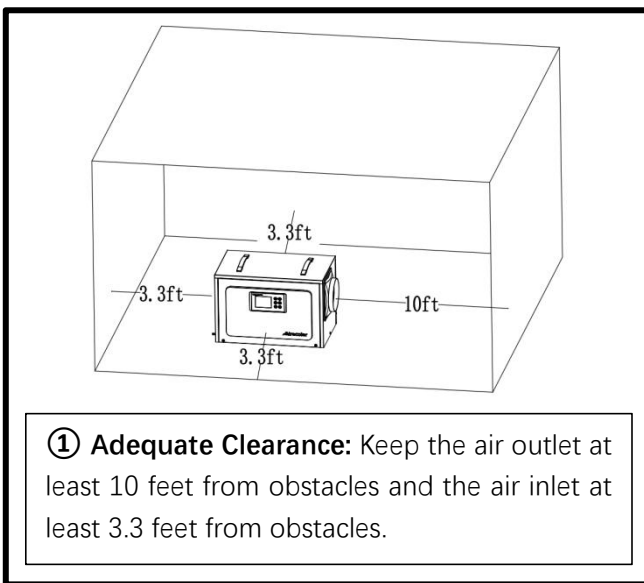

Following either of the above recommendations will help prevent the discharged air from being drawn back into the unit, ensuring the dehumidifier operates effectively.

3. Position Your Dehumidifier

- Position the dehumidifier horizontally during installation to minimize vibrations and noise.
- For optimal performance, operate the dehumidifier in an enclosed area with all doors and windows closed to maximize water removal efficiency.
- Keep the dehumidifier away from obstructions and ensure ample space for airflow into and out of the unit.

4. Set up the Drainage System

Before turning on the dehumidifier, ensure the drain hose is securely connected to the correct drain outlet. The dehumidifier offers two drainage options: internal pump or gravity. Choose the method that best suits your needs.

4.1 Drain by Internal Pump

Use the internal pump for draining over long distances or upward. Follow these steps:

- ① Seal the Gravity Drain Outlet with the included stopper;
- ② Uncoil the 5m hose and connect it to the pump drain outlet;
- ③ Direct the hose to a sink, drain, bucket or outdoors—anywhere that water can drain safely.
- ④ Ensure there are no kinks or other obstructions that could impede water flow.

NOTE:

- This dehumidifier includes a built-in pump that **automatically activates** when the internal water level reaches a certain level.
- The **Purge** button allows you to manually activate the pump when necessary.
- If using a bucket or container for drainage, check it regularly to avoid overflow.
- The pump can drain water vertically up to 16.4 ft. Exceeding this distance may cause water backup and leakage.
- Avoid using a hose that is too long, as it may lead to incomplete drainage and mould growth.
- Before moving the dehumidifier, please remove the stopper from the Gravity Drain Outlet to completely drain the condensation in the internal water tray to avoid water leakage.

4.2 Drain by Gravity

If the drainage point is below the gravity drain outlet and located nearby, with no upward lift required, you may use gravity drainage.

When using gravity to drain:

- Attach the gravity drain hose to the Gravity Drain Outlet.
- Direct the hose to a suitable drainage facility, ensuring it is positioned lower than the dehumidifier's drain outlet and free from kinks or blockages.

OPERATION INSTRUCTIONS

1. Plug in the Electrical Cord

IMPORTANT

Please allow the dehumidifier to sit outside the box for **24** hours before initial use.

The dehumidifier needs to be plugged into a properly grounded 120-volt outlet rated for at least 10 amps. Uncoil the power cord and firmly plug it into a suitable outlet.

NOTE: When the dehumidifier is plugged in, the  icon on the control panel display will illuminate.

2. Control Panel Instructions

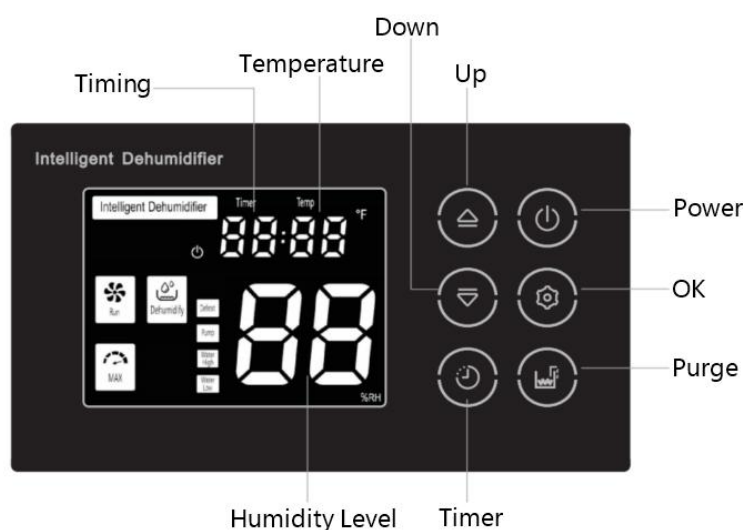

2.1 The Control Buttons

- **Power Button:** Press to toggle the dehumidifier on/off.
- **OK Button:** Press to confirm settings for humidity and/or timer.
- **Up Button:** Press to increase humidity or timer settings.
- **Down Button:** Press to decrease humidity or timer settings.
- **Timer Button:** Press to set a timer.
- **Purge Button:** Press to manually activate the pump.

Note: If you use the internal pump for drainage (with the gravity drainage port sealed), the dehumidifier will automatically drain condensation when the internal water tray is near full. There is no need to press any button to activate the pump during normal operation.

The Purge function is intended for specific situations only:

Before moving the dehumidifier, to prevent leaks

Before storing the unit, to remove residual water and prevent mold

2.2 The LCD Displays

 Lights up when the dehumidifier is plugged in but not yet turned on.

 Lights up when the dehumidifier is turned on; off when it's turned off.

 The steady %RH display represents the current room humidity percentage. When adjusting the target humidity percentage value by pressing the Up or Down button, this number flashes the previous setting and updates according to your adjustments until the new setting is confirmed.

 **Run Icon:** Lights up when the fan is running; off when the fan stops.

 **Dehumidify Icon:** Flickers when the compressor has not activated, typically during: ① 3-minute compressor delay status; or ② Delay-start programmed (AUTO ON TIMER).

 **MAX Icon:** Lights up in Continuous Mode with a set humidity value of 10%.

 **Defrost Icon:** Flashes during the defrosting process. During defrosting, the fan operates, but the compressor does not. Once defrosting is complete, the icon disappears and dehumidification resumes.

NOTE: Frequent defrosting may occur when the room temperature is too low, which can reduce dehumidification efficiency. For optimal performance, keep the room temperature above 65 °F. If the temperature is below 60 °F, consider adding heat to maintain proper drying.



 **Pump Icon:** Lights up once the dehumidifier is turned on, indicating the pump is in good condition. It flashes when the pump is actively draining condensate.

 **Water High Icon:** Lights up when the pump is automatically draining water.

 **Water Low Icon:** Lights up when the pump's water level is low and hasn't reached the threshold for automatic drainage yet.

3. Operate the Dehumidifier

3.1 Turn on the Dehumidifier

Press the **Power** button to turn the dehumidifier on. When turned on, the  icon will turn off, and the  icon will illuminate.

3.2 Check Room Humidity

Refer to the  on the control panel to check the current room humidity percentage.

3.3 Set Desired Humidity

Press the **Up** or **Down** button to set your desired humidity between 10% and 90%, in 1% increments. Recommended settings typically range between 40% and 60%. The  digital number will turn to display the previous target humidity set point and blink to indicate the setting is being adjusted.

Ensure the set humidity is at least 5% lower than the room humidity. After selecting your target value, press the OK Button to confirm your setting or wait for automatic registration after 5 seconds.

Once a target humidity is set, the dehumidifier will automatically cycle on and off to maintain humidity within $\pm 3\%$ of the set level:

- The unit will run until the humidity drops to 3% below the target, then enter standby mode — the compressor and fan stop, and the display begins blinking.
- When the humidity rises to 3% above the target, the dehumidifier will automatically restart and run until it again reaches 3% below the set level.

Note 1: The target humidity needs to be at least 3% lower than the current room humidity. If not, the unit will remain in standby mode with a blinking display until the room humidity rises 3% above the target.

Note 2: To run the unit continuously, set the target humidity to 10% to activate Continuous Mode.

3.4 Set Auto On/Off Timer

The TIMER function allows scheduling the dehumidifier to turn on (AUTO-ON) or off (AUTO-OFF) after a delay of 1 to 24 hours.

- **To set AUTO-ON timer:** When the dehumidifier is off, selecting Timer activates it after the set hours.
- **To set AUTO-OFF timer:** When the dehumidifier is on, selecting Timer turns it off after the set hours.

Follow these steps to set the TIMER:

- Press the Timer Button, the Timer icon illuminates and the timer digital number changes into 00 H, flashing.
- Adjust the timer setting by pressing the Up or Down button for 1-hour increments, up to 24 hours.
- After selecting the target timer value, press the OK Button to confirm your setting or wait for automatic confirmation after 5 seconds.
- The timer countdown displays remaining time until the dehumidifier starts or stops.
- To disable the timer function, manually turn ON/OFF the dehumidifier, or set the timer to 00.

NOTE:

- Ensure power is supplied to the dehumidifier before setting AUTO ON TIMER.
- For AUTO ON setting, turn on the dehumidifier to select a desired humidity level first; otherwise, it maintains the previous setting.
- You can only set AUTO ON timer when the dehumidifier is off or set AUTO OFF timer when it's on, but not be able to set both AUTO ON and AUTO OFF timer simultaneously.
- TIMER functions only once, not cycling the dehumidifier indefinitely.
- TIMER is disabled if the dehumidifier is manually powered on/off.

3.5 Turn the Dehumidifier off

Press the **Power** button to turn off the dehumidifier. When the dehumidifier is turned off, the  icon illuminates, and the  icon turns off.

NOTE: To protect the compressor, the fan runs for 5 seconds after the dehumidifier shuts off. So please do not disconnect the power cord to force the dehumidifier to stop. Always use the **Power** button.

4. Water Drainage

4.1 Drain by Internal Pump

If you seal the gravity drain and connect the pump drain hose, the dehumidifier will automatically drain the condensate when the internal reservoir is full. No manual intervention required!

The Pump icon blinks when the pump is draining. The pump stops automatically after 170 seconds, and the blinking Pump icon stops when the internal water tray is nearly empty.

NOTE: If the unit does not drain or fails to drain automatically after setting up the pump drainage as instructed above, please contact service@airecoler.com for assistance.

4.2 Drain by Gravity

If you connect the gravity drain hose, you are choosing to drain by gravity. In this case, the dehumidifier will automatically drain condensation through the gravity drain outlet. However, the drain hose needs to slope downward to a lower drainage facility. If the hose does not slope downward, the water may not drain properly, potentially causing leakage.

NOTE: If the drain hose is directed to a bucket, regularly check and empty the bucket to prevent overflowing.

SMART FUNCTIONS

1. Compressor 3-Minute Delay

To prevent any potential damage, the dehumidifier incorporates a 3-minute delay after a complete cycle. Following this interval, the compressor automatically starts operation. In essence, if you power off and restart the dehumidifier immediately, the compressor initiates after a 3-minute delay. During this period, you can see the Dehumidify icon flashing on the LCD screen until the compressor starts.

2. Auto Defrost

If the temperature drops below 60°F, frost may form on the coils. When this happens, the unit will automatically pause the compressor and run the fan to defrost. The Defrost icon will illuminate during this process. Once the frost has cleared, the unit will resume normal operation.

3. Auto-Restart

If a power outage occurs while the dehumidifier is running, it will automatically restart with the previous settings (excluding the timer) once power is restored.

4. Temperature Protection Function

- If the room temperature exceeds 100°F, the dehumidifier will automatically enter into HIGH-TEMPERATURE PROTECTION SYSTEM, displaying "-H" on the LCD screen, and the compressor stops.
- If the room temperature falls below 40°F, the dehumidifier will automatically enter into LOW-TEMPERATURE PROTECTION SYSTEM, displaying "-L" on the LCD screen, and the compressor stops.

NOTE: Contact Airecoler customer service at service@airecoler.com for technical support if encountering "-H" or "-L" messages in normal circumstances.

CARE & MAINTENANCE

WARNING:

Ensure the dehumidifier is turned OFF and unplugged before performing any cleaning or maintenance.

1. Cleaning the Dehumidifier

- Wipe the dehumidifier housing with a soft damp cloth.
- Avoid submerging or applying water directly to the dehumidifier or control panel to prevent damage to electronic components.
- Do not use chemical solvents such as benzene, alcohol, gasoline or other heavy-duty cleaners, as they may harm the surface.

2. Cleaning the Air Filter

A blocked filter can impede performance. Clean the air filter every 2 weeks or more frequently in dusty or pet-fur-laden environments. The air filter is located behind the inlet grill.

Follow the steps below to clean the filter:

- Pull to the left to take the filter out.
- Use a vacuum cleaner with a soft brush attachment to remove large debris or dust.
- Wash the filter in lukewarm, soapy water (below 104°F) or use a neutral cleaning agent.
- Rinse the filter with clean water and thoroughly dry it.
- Re-install the filter.

NOTE: DO NOT operate the dehumidifier without a filter, as dirt and lint may clog it, reducing performance.

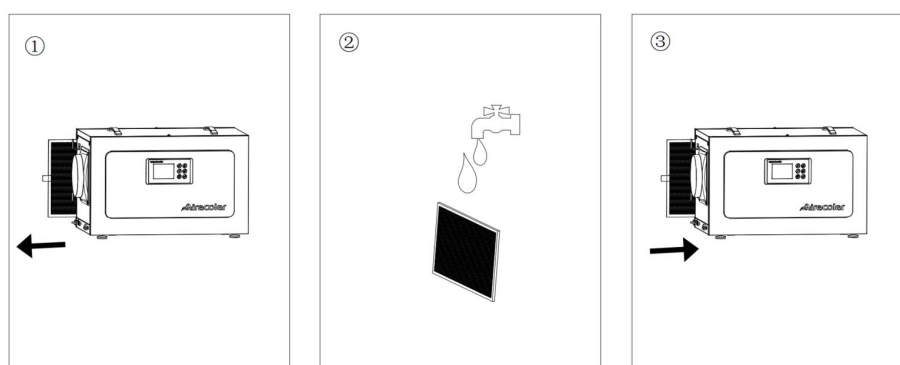

3. Storage Guidelines

- Turn off the unit, disconnect power, and remove the gravity drainage plug.
- Let the unit sit for 24 hours to allow all internal water to drain completely.
- Clean the dehumidifier and air filter thoroughly, ensuring everything is clean and dry.
- Wrap the cord and hose, bundling them for safekeeping.
- Cover the dehumidifier with a plastic bag to protect it from dust and debris.
- Store the dehumidifier upright in a dry, well-ventilated place.

TROUBLESHOOTING TIPS

The following chart provides solutions for common problems that may arise. If the issue persists after troubleshooting, or if it's not addressed in the chart below, please contact Airecoler customer service for professional support at service@airecoler.com.

Problem	Possible Causes	Solutions
Dehumidifier does not operate	No power to dehumidifier	Plug it into a working outlet
	Not turned on	Turn the dehumidifier on
	Error code displays	Contact customer service
Dehumidifier collects little water	Insufficient working time	Allow more working time
	Filter is blocked	Clean the filter
	Air Inlet or Outlet is blocked	Clear the obstructions
	Room temperature is low	Heat up the room
	Condensate hose is blocked	Check the hose for restrictions
Dehumidifier operating, but room not dry	Doors and windows are open	Seal room from external areas
	Insufficient working time	Allow more working time
Abnormal Noise	Dehumidifier not placed properly	Place the dehumidifier in a horizontal position
	Filter is blocked	Clean the filter

NOTE: It is normal that the dehumidifier pulls warm air out.

ERROR CODES AND SOLUTIONS

Codes	Solutions
E1,E4	Replace the temperature and humidity sensor
E2	Replace the defrost temperature sensor
E3	Contact customer service
E6	Eliminate the abnormality of the display panel connection line, and ensure that the DISPLAY interface is connected
-H	Non-faulty, the dehumidifier will automatically resume operation after the room temperature drops
-L	Non-faulty, the dehumidifier will automatically resume operation after the room temperature rises

NOTE:

When E1, E2 and E4 error occur, the dehumidifier can operate normally but it cannot be controlled intelligently. The dehumidifier will automatically resume operation after the fault is eliminated. If the problems persist, please turn off and unplug the dehumidifier, and contact Airecoler customer service at service@airecoler.com

WARRANTY

This warranty applies only to products purchased from Airecoler or its authorized dealers and must be installed, operated, and maintained according to the provided instructions.

2 Years Full Warranty (1 year standard + 1 year with product registration)

Airecoler warrants to the original purchaser that this product is free from defects in materials and workmanship for 2 years from the date of purchase. During this period, Airecoler will, at its discretion, repair or replace any defective parts or units. In rare cases where repair or replacement is not feasible, a refund may be issued as a last resort.

5-Year Limited Warranty on Refrigeration System

The refrigeration system—including compressor, condenser, and evaporator—is warranted against defects in materials or workmanship for five years from the purchase date. Labor and shipping costs are excluded after the initial two-year full warranty period.

Note: If the dehumidifier is replaced, the warranty period for the replacement dehumidifier continues from the original purchase date.

Exclusions

This warranty does not cover:

(1) Damage resulting from:

- Normal wear and tear
- Misuse, abuse, accidents, or failure to follow the operating instructions
- Exposure to liquids or foreign particles
- Unauthorized servicing or modifications

(2) Second-hand products or products purchased through liquidation sales.

(3) Products purchased from unauthorized dealers.

While these terms define our warranty, we encourage customers to contact us with any concerns, regardless of warranty status. We are committed to delivering the best possible support.

For assistance, please contact Airecoler Customer Service as follows:

 **Website:** www.airecoler.com

 **Phone:** [Available via our website](#)

 **Email:** service@airecoler.com

 **Live Chat:** [Available via our website](#)



www.airecoler.com