

5282011

Digital Weather Forecaster



Thank you for purchasing a Taylor digital weather forecaster. This weather instrument is an example of superior design and craftsmanship. Please read instructions thoroughly to ensure that you have the full benefit of all the unit's features. Keep these instructions handy for future reference.

BATTERY INSTALLATION AND INITIAL SET UP

The weather forecaster can operate on either two (2) 1.5V AAA batteries (not included) or USB cord (included).

- The battery compartment is located on the back of the weather forecaster. Insert 2 AAA batteries into the battery compartment according to the "+" and "-" polarity symbols. Replace the battery compartment cover.

OR

Insert the small end of the USB cord into the port located on the back of the weather forecaster. Then plug the USB (larger end) into a wall outlet converter and into the wall outlet. Please note, you will need to use your own wall outlet converter to plug the cord into.

- The weather forecaster will beep and the LCD will light up.
- Open the battery compartment located on the front of the wireless sensor. Insert two (2) AAA batteries according to the "+" and "-" polarity symbols. Replace the battery compartment cover.
- The weather forecaster will begin connecting to the wireless sensor. The outdoor temperature and humidity will display a flashing "--.-".
- Once the weather forecaster and wireless sensor have been successfully connected, the outdoor temperature and humidity readings will be displayed on the forecaster along with the selected Channel number (1, 2, or 3). To change channels on the wireless sensor, open the battery compartment and manually switch to the desired channel.
- If the wireless sensor does not pair with the forecaster within 3 minutes, "--.-" will appear on the display. Check the batteries on the wireless sensor and if there is any source of interference nearby (for example, computer monitors, television sets, etc).

- To manually pair the wireless sensor and weather forecaster, press and hold the **▲CHANNEL** button located on the back of the forecaster for 3 seconds and "--.-" appears on the display. Press the **TX** button located in the battery compartment of the wireless sensor. The forecaster will beep and receive the readings from the wireless sensor. Replace the battery compartment cover on the wireless sensor.

Change the batteries in the weather forecaster when the battery symbol appears on the indoor values display. Change the batteries in the wireless sensor when the battery symbol appears on the outdoor values display. When batteries are changed, the connection between weather forecaster and wireless sensor(s) must be restored so always insert new batteries into both units or start a manual transmitter search.

NOTE: The LCD display will automatically dim while using battery power to conserve energy, press the **LIGHT** button on the back of the forecaster to illuminate the LCD. The LCD display will remain fully lit while being powered by the USB cord.

Do not mix old and new batteries. Do not mix alkaline, standard (carbon-zinc) or rechargeable (nicad, ni-mh, etc.) batteries.

NOTE: Please recycle or dispose of batteries per local regulations.

WARNING: Batteries may pose a choking hazard. As with all small items, do not let children handle batteries. If swallowed, seek medical attention immediately.

PRECAUTION: Do not dispose of batteries in fire. Batteries may explode or leak. Remove the batteries if the scale will not be used for a long period of time

DESCRIPTION OF PARTS

A11 A10

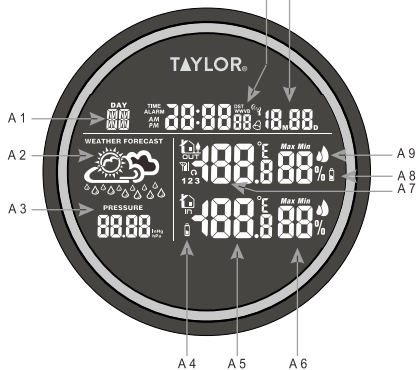

- A1:** Day of the Week
- A2:** Weather Forecast
- A3:** Barometric Pressure
- A4:** Forecaster Battery Icon
- A5:** Indoor Temperature
- A6:** Indoor Humidity
- A7:** Outdoor Temperature
- A8:** Wireless sensor battery icon
- A9:** Outdoor Humidity
- A10:** Date, Month/Day
- A11:** Time

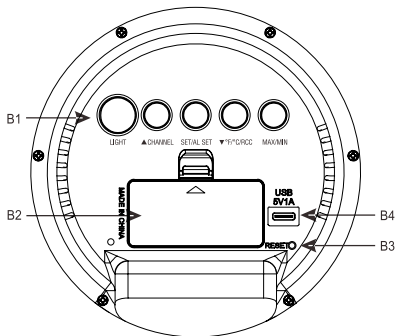

- B1:** Control Buttons (LIGHT, ▲CHANNEL, SET/AL SET, ▼°F/°C/RCC, MAX/MIN)
- B2:** Battery Compartment
- B3:** Reset Button
- B4:** USB port (Type-C input plug)
- B5:** Support Foot

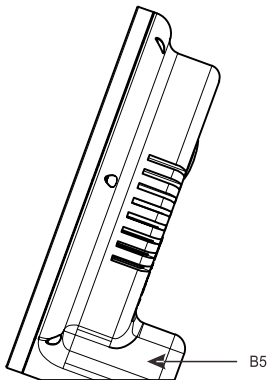

C1: Wall Mounting Hole

C2: LED Index

C3: Battery Compartment

C4: Channel Switch (1-2-3)

C5: TX Button

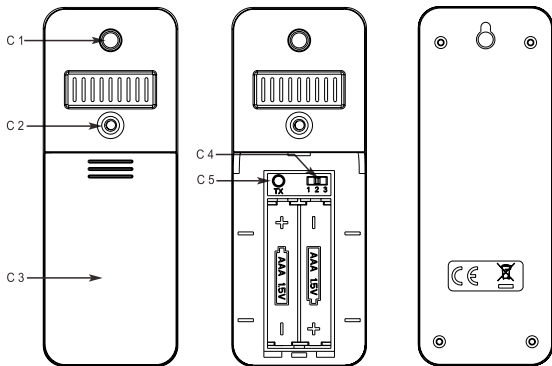

RADIO SIGNAL RECEPTION

Once the weather forecaster receives the outdoor temperature and humidity readings, it will scan the RCC frequency signal and the RCC symbol will flash on the display. During the Radio Control receiving mode, only the ▼F/°C/RCC button will operate. All other button operations will not function.

When the time code is successfully received (this will take between 2 – 12 minutes), the radio controlled time and RCC symbol are steadily displayed on the LCD and all of the control buttons are activated again.

To manually start signal reception, press and hold the ▼F/°C/RCC button for 3 seconds. The RCC symbol will flash. To stop searching radio signal during Radio Control reception, press the ▼F/°C/RCC button again and the DCF symbol disappears.

The RCC reception always occurs hourly between 2:00am and 5:00am. If the reception is not successfully received until 5:00am, the next reception will take place again at 2:00am.

There are four different reception symbols:



flashing - reception is active



stays - reception is very good



just tower - RCC function ON
no reception

no symbol - RCC function OFF
time is manually set

If the clock cannot detect the RCC signal due to disturbances, transmitting distance, etc., the time can be set manually. The RCC symbol disappears and the clock will work as a normal quartz clock (see Manual Settings). If RCC is not needed, the function can be turned off (see Manual Settings).

NOTE: It is recommended to have a minimum distance of 5 to 6.5ft. (1.5 to 2 meters) to all sources of interference, such as televisions or computer monitors. Radio reception is weaker in rooms with concrete walls (e.g.: in cellars) and in offices. In such extreme circumstances, place the system close to a window. During night time, the atmospheric interference is usually less severe and reception is possible in most cases. A single daily reception is adequate to keep the accuracy deviation under 1 second.

MANUAL TIME SETTING

Press and hold **SET/AL SET** for 3 seconds while in normal mode to enter the setting mode.

The Time Zone starts to flash. Press **▲CHANNEL** or **▼°F/°C/RCC** to select the desired time zone (06=HAT, 05=AKT, 04=PST, 03=MST, 02=CST, 01=EST, 00=AST). Press **SET/AL SET** to confirm.

NOTE: The default time zone is set to PST (04).

The Daylight Savings Time (DST) display starts to flash. Press **▲CHANNEL** or **▼°F/°C/RCC** to set DST on or off. Press **SET/AL SET** to confirm.

The 12/24 hour mode starts to flash. Press **▲CHANNEL** or **▼°F/°C/RCC** to select between 12 or 24 hour format. Press **SET/AL SET** to confirm.

The hour display starts to flash. Press **▲CHANNEL** or **▼°F/°C/RCC** to set the correct hour. Press **SET/AL SET** to confirm.

The minute display starts to flash. Press **▲CHANNEL** or **▼°F/°C/RCC** to set the correct minutes. Press **SET/AL SET** to confirm.

The year 2019 display starts to flash. Press **▲CHANNEL** or **▼°F/°C/RCC** to set the correct year. Press **SET/AL SET** to confirm.

The month display starts to flash. Press **▲CHANNEL** or **▼°F/°C/RCC** to set the correct month. Press **SET/AL SET** to confirm.

The date display starts to flash. Press **▲CHANNEL** or **▼°F/°C/RCC** to set the correct date. Press **SET/AL SET** to confirm.

The day display starts to flash. Press **▲CHANNEL** or **▼°F/°C/RCC** to set the correct day and language. There are 7 languages of weekday: English, German, Italian, French, Dutch, Spanish, and Danish.

Press **SET/AL SET** to confirm.

MANUAL TIME SETTING (cont.)

Language	German	English	Italian	French	Dutch	Spanish	Danish
Abbreviation	GER	ENG	ITA	FRE	DUT	SPA	DAN
Sunday	SON	SUN	DOM	DIM	ZON	DOM	SON
Monday	MON	MON	LUN	LUN	MAA	LUN	MAN
Tuesday	DIE	TUE	MAR	MAR	DIN	MAR	TIR
Wednesday	MIT	WED	MER	MER	WOE	MIE	ONS
Thursday	DON	THU	GIO	JEU	DON	JUE	TOR
Friday	FRE	FRI	VEN	VEN	VRI	VIE	FRE
Saturday	SAM	SAT	SAB	SAM	ZAT	SAB	LOR

NOTE: The weather forecaster will automatically exit setting mode if buttons have not been pressed after a period of time. Press and hold the ▲CHANNEL or ▼°F/°C/RCC buttons during set up to scroll through settings faster.

SETTING DAILY ALARMS

Press SET/AL SET to enter alarm mode, "ALARM" is displayed and 12:00am is the default time. Press ▲CHANNEL or ▼°F/°C/RCC to turn the alarm on or off. If the 📞 symbol is displayed, the alarm function is activated.

While in alarm setting mode, press and hold SET/AL SET for 3 seconds. The hour display starts to flash. Press ▲CHANNEL or ▼°F/°C/RCC to set the desired hour.

Press SET/AL SET and the minutes display starts to flash. Press ▲CHANNEL or ▼°F/°C/RCC to set the desired minutes. Press SET/AL SET to confirm the alarm setting and the forecaster returns to normal mode.

The alarm will sound and the 📞 symbol will flash once the designated time has been reached.

NOTE: Press any button to stop the alarm. If any buttons are not pressed, the alarm will automatically shut off after 2 minutes.

WEATHER FORECAST

The weather forecast function indicates a general weather trend over a span of 12 hours with about a 70% accuracy level.

The weather forecaster has 4 different weather symbols:



sunny



partly cloudy



cloudy



rainy

The weather forecast symbols will become more defined throughout use. The weather forecast function is active from initial set up however the reliability increases with the amount of data collected over time. The forecast function does not indicate the current weather at the moment, it forecasts the weather trend over the span of 12 hours.

NOTE: If the current weather is cloudy and the rain symbol is displayed yet not raining outside, it does not mean the weather forecaster is malfunctioning. This means the air pressure has dropped and the weather is expected to worsen but not necessarily rain. Also, the sun symbol appears at night if it is a clear, starry night.

THERMOMETER & HYGROMETER

Press **MAX/MIN** to display the maximum and minimum values on the LCD. Press and hold **MIN/MAX** for 3 seconds to clear the maximum and minimum memory.

During normal mode, press **▼°F/°C/RCC** to switch between Celsius (°C) and Fahrenheit (°F) temperature units.

NOTE: If the measured values are above the range, the temperature will display "HH.H" and humidity will display "HH%". If the measured values are below the range, the temperature will display "LL.L" and humidity will display "LL%".

ADDITIONAL WIRELESS SENSORS

You may register additional wireless sensors to the weather forecaster. Select the channel by using the 1/2/3 switch inside the battery compartment of the wireless sensor. The reception of the new wireless sensor will be transmitted automatically to the weather forecaster. Press and hold ▲CHANNEL on the weather forecaster or restart it completely.

The outdoor temperature and humidity readings will appear on the display. If more than one wireless sensor is paired with the weather forecaster, press ▲CHANNEL on the forecaster to change between channels 1, 2 or 3.

To have alternating channels displayed, press ▲CHANNEL after the third channel and the cycle symbol " " appears.

Press ▲CHANNEL again to deactivate the alternating channel display and it defaults to channel 1.

To delete registered channels, press and hold ▲CHANNEL for 3 seconds.

NOTE: Each channel can be individually registered. For example, hold ▲CHANNEL for 3 seconds in channel 1, then channel 1 will be deleted and re-registered (channels 2 and 3 will remain unchanged). After changing batteries in the wireless sensors, press and hold ▲CHANNEL for 3 seconds to re-register the sensor.

SPECIFICATIONS

- Indoor temperature range: 14°F to 122°F (-10°C to 50°C)
- Outdoor temperature range: -40°F to 140°F (-40°C to 60°C)

Accuracy:

- Temperature +/-1°C(2°F) between 0°C to 50°C, otherwise +/-2°C(4°F)
- Humidity +/-5% between 30% to 70%, otherwise +/-8%

- Indoor humidity range: 20% to 95%
- Outdoor humidity range: 1% to 99%
- Air pressure measuring
- Radio control clock
- Transmission distance: 200 ft (60m) in free field
- Transmission frequency:433.92MHz
- Transmission time: CH1, 50 seconds; CH2, 53 second; CH3, 56 seconds
- Weather forecast: sunny, partly cloudy, cloudy, rainy

Power:

- Receiver: (2) 1.5V AAA batteries (not included) or Type-C USB cord 5V/1A (included)
- Wireless sensor: (2) x 1.5V AAA batteries (not included)

TROUBLESHOOTING

Weather forecaster is not displaying readings

- Double check batteries are inserted correctly according to the polarity symbols
- Change the batteries

No RCC reception

- Press and hold ▼°F/°C/RCC for 3 seconds and manually start the initialization
- Wait for attempted reception during the night
- Choose another location for the weather forecaster and/or wireless sensor
- Set the clock manually
- Check for any sources of interference
- Restart the weather forecaster according to the instructions

Low battery symbol or incorrect readings displayed

- Change the batteries

PRECAUTIONS

1. The weather forecaster is intended for indoor use only. It is not sealed against moisture and could be damaged if used outdoors. Do not immerse it in water or allow snow to accumulate on it. Do not leave it outdoors in extreme weather conditions. Otherwise, permanent damage to the unit's internal circuits may occur.
2. The wireless sensor is protected against water splashes, but it is not watertight. Choose a shady and dry position outside for the wireless sensor(s).
3. Do not immerse the units in water. If you spill liquid on one, dry immediately with a soft, lint-free cloth.
4. Do not clean the units with abrasive or corrosive materials. This may scratch plastic parts and corrode electronic circuits.
5. Do not subject unit to excessive force, shock, dust, temperature or humidity. This may result in malfunction, shorter electronic life span, damaged batteries or distorted parts.
6. Do not tamper with the units' internal components. Doing so will invalidate the warranty on this product and may cause damage. The units contain no user serviceable parts.
7. Do not mix old and new batteries. Do not mix alkaline, standard (carbon-zinc) or rechargeable (ni-cad, ni-mh, etc.) batteries. Do not dispose of batteries in fire. Batteries may explode or leak. Remove the batteries/charger if the units will not be used for a long period of time.
8. Never dispose of empty batteries and rechargeable batteries in household waste. As a consumer, you are legally required to take them to your retail store or to an appropriate collection site depending on national or local regulations in order to protect the environment. The symbols for the heavy metals contained are: Cd=cadmium, Hg = mercury; Pb=lead. This instrument is labelled in accordance with the EU Waste Electrical and Electronic Equipment. Directive (WEEE).
9. Please do not dispose of this instrument in household waste. The user is obligated to take end-of-life devices to a designated collection point for the disposal of electrical and electronic equipment, in order to ensure environmentally-compatible disposal.
10. This product is for measuring weather temperatures only. DO NOT PLACE UNITS INTO OVENS, GRILLS, FREEZERS or MICROWAVE OVENS.
11. Keep the base station out of direct sunlight and away from sources of heat.
12. Always read the instruction manual before operating this product.

**Party issuing Supplier's Declaration of Conformity &
Responsible party – U.S. Contact information:**

Taylor
2311 W. 22nd Street, Suite 200
Oak Brook, IL 60523

Equipment:

Product Name: Digital Weather Forecaster
Model No.: 5282011
Trade Name: Taylor

We declare under our sole responsibility that the above referenced product has been tested according to FCC requirements and this device complies with part 15 of the FCC Rules. Operation is subject to the following two conditions: (1) this device may not cause harmful interference, and (2) this device must accept any interference received, including interference that may cause undesired operation.

Caution: Changes or modifications not expressly approved by the party responsible for compliance could void the user's authority to operate the equipment.

Note: This equipment has been tested and found to comply with the limits for a Class B digital device, pursuant to part 15 of the FCC rules. These limits are designed to provide reasonable protection against harmful interference in a residential installation. This equipment generates, uses and can radiate radio frequency energy and, if not installed and used in accordance with the instructions, may cause harmful interference to radio communications. However, there is no guarantee that interference will not occur in a particular installation. If this equipment does cause harmful interference to radio or television reception, which can be determined by turning the equipment off and on. The user is encouraged to try to correct the interference by one or more of the following measures:

- Reorient or relocate the receiving antenna.
- Increase the separation between the equipment and receiver.
- Connect the equipment into an outlet on a circuit different from that to which the receiver is connected.
- Consult the dealer or an experienced radio/TV technician for help.

LIMITED WARRANTY

This product is warranted against defects in materials or workmanship (excluding batteries, USB cord, adapters) for one (1) year from date of original purchase for the original purchaser. It does not cover damages or wear resulting from accident, misuse, abuse, commercial use, or unauthorized adjustment and/or repair. Should this product require service (or replacement at our option) while under warranty, do not return to retailer. Please pack the item carefully and return it prepaid, along with store receipt showing date of purchase and a note explaining reason for return to:

TAYLOR

2220 Entrada Del Sol, Suite A | Las Cruces, New Mexico | 88001 USA

Email: taylorusa@lifetimebrands.com | www.taylorusa.com

There are no expressed warranties except as listed above. This warranty gives you specific legal rights, and you may have other rights which vary from state to state. For additional product information, or warranty information outside the USA, please contact us through www.taylorusa.com.

©2021 Taylor division of Lifetime Brands Inc. All rights reserved.

**Made to our exact specifications in China.
Not legal for trade.**