



## 30-INCH DOUBLE WALL OVEN

HWO230 | HERITAGE COLLECTION



### AVAILABLE MODELS

HWO230ES	Heritage 30" Double Wall Oven - Stainless Steel with Epicure Style Handle
HWO230PS	Heritage 30" Double Wall Oven - Stainless Steel with Pro Style Handle
HWO230FS	Heritage 30" Double Wall Oven - Stainless Steel with Flush Handle
HWO230EB	Heritage 30" Double Wall Oven - Black Glass with Epicure Style Black Handle
HWO230PB	Heritage 30" Double Wall Oven - Black Glass with Pro Style Stainless Steel Handle
HWO230EC	Heritage 30" Double Wall Oven - DacorMatch Color System with Epicure Style Color Matching Handle
HWO230PC	Heritage 30" Double Wall Oven - DacorMatch Color System with Pro Style Color Matching Handle (End Caps in Stainless Steel)
HWO230FC	Heritage 30" Double Wall Oven - DacorMatch Color System with Flush Handle

### FEATURES & BENEFITS

- Four-Part Pure Convection System provides superior heat distribution, and eliminates flavor transfer.
- RapidHeat™ Broil Element uses an 8-pass radiant ribbon element to broil food quickly and evenly.
- 4.8 cu. ft. oven capacity.
- 7 rack positions for multi-rack cooking.
- SoftShut™ doors.
- GlideRacks
- Self-Cleaning mode.
- Sabbath mode.

### ACCESSORIES (INCLUDED)

GLIDERACK™	2 (UPPER) / 2 (LOWER)
STANDARD RACK	1 (UPPER) / 1 (LOWER)
TEMPERATURE PROBE	1

### ACCESSORIES (OPTIONAL)

COOKIE SHEETS (SET OF 3)	ACSRO303
BROIL-ROASTING PAN SET	AORPVR
PIZZA STONE	ABS16

### GENERAL PROPERTIES

COOKING MODES BOTH CAVITIES	PURE CONVECTION™ CONVECTION BAKE CONVECTION BROIL CONVECTION ROAST BAKE BROIL
--------------------------------	--

### ADDITIONAL FEATURES

CLEANING TYPE	SELF CLEAN & GREENCLEAN™
RACK POSITIONS	7
CONVECTION TYPE	PURE CONVECTION™
LIGHTING	HALOGEN

### OVEN PERFORMANCE

BAKE ELEMENT	3,000W - 8 PASS
BROIL ELEMENT	3,500W - 8 PASS
CONVECTION ELEMENT	2,200W

### CONTROL FEATURES

DELAY TIME COOKING	YES
TIMED COOKING	YES
AUTOMATIC HOLD	YES
10-KEY PAD	YES
CLOCK	YES
TWO TIMERS	YES
SABBATH MODE	YES
CHILD LOCK	YES

### ADDITIONAL MODES

KEEP WARM	YES
PROOF	YES
DEHYDRATE	YES
TEMPERATURE PROBE	YES

### TECHNICAL DETAILS

CIRCUIT BREAKER (A)	50
VOLTS (V)	240
FREQUENCY (HZ)	60
ENERGY SOURCE	ELECTRIC

### DIMENSIONS & WEIGHT

APPLIANCE DIMENSIONS (H X W X D) (IN.)	50 1/8" X 29 7/8" X 24"
REQUIRED CUTOUT SIZE (H X W X D) (IN.)	49 1/8" X 25 5/8" X 24"
OVEN CAPACITY (CUBIC FEET)	4.8

### WARRANTY

LIMITED, PARTS AND LABOR	1 YEAR
--------------------------	--------

# dacor

## 30-INCH DOUBLE WALL OVEN

### APPLIANCE DIMENSIONS

30"

A	29 7/8" (75.9 CM)	WIDTH (FACE)
B	28 1/2" (72.4 CM)	WIDTH (CHASSIS)
C	50 1/8" (127.3 CM)	HEIGHT (OVERALL)
D	49" (124.5 CM)	HEIGHT (CHASSIS)
E	1 1/8" (2.9 CM)	TOP OF CHASSIS TO TOP OF CONTROL PANEL
F	6 1/2" (16.5 CM)	UTILITY CUTOUT (WIDTH)
G	5" (12.7 CM)	UTILITY CUTOUT (HEIGHT)
H	7 7/8" (20.0 CM)	UTILITY CUTOUT (DEPTH)
J	1 1/8" (3.2 CM)	CONTROL PANEL (DEPTH)
K	23 5/8" (60 CM)	DEPTH (CHASSIS)

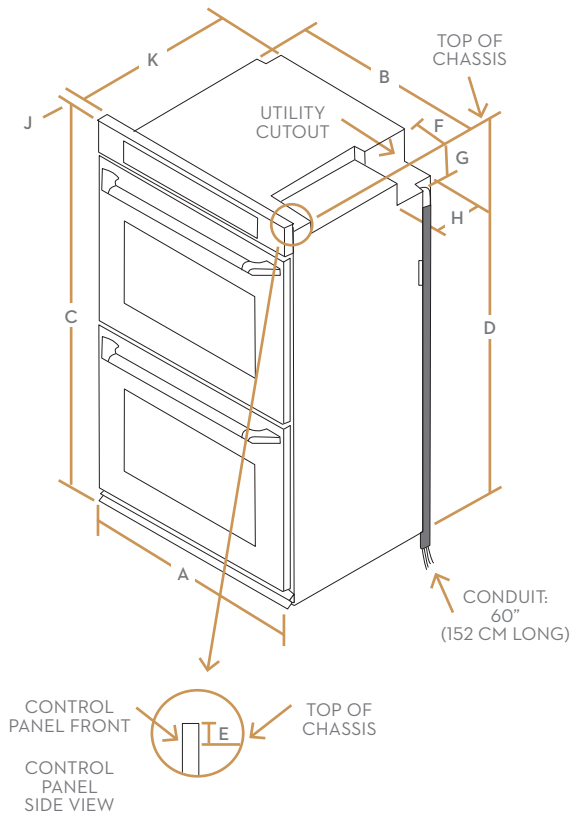

### INSTALLATION CUTOUT DIMENSIONS

CABINET	INSTALL DIMENSION
N	30" (76.2 CM)
P	MIN. 28 5/8" (72.7 CM) RECOMMENDED MAX. 29 1/8" (74.0 CM)
R	MIN. 49 1/8" (124.8 CM) RECOMMENDED MAX. 50" (127.0 CM)

### WALL CABINET

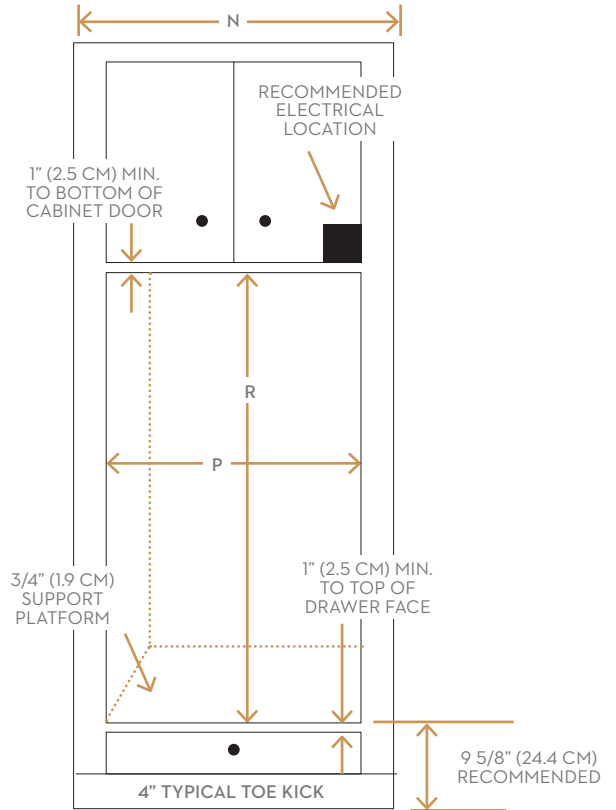

### HANDLE DIMENSIONS

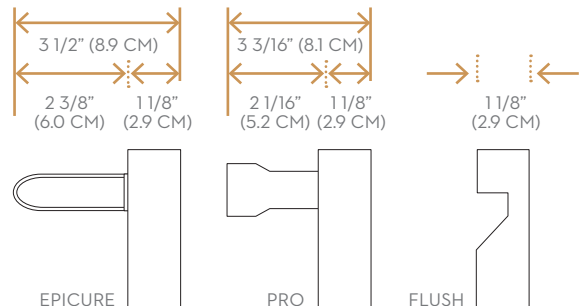

All tolerances:  $\pm 1/16$  (+/-1.6MM) unless otherwise stated.