

MODEL: MS-174
 INSTRUCTION MANUAL (BACK)
 DATE : Sept 13, 2019
 SIZE: 180 L x 230 H mm
 COLOR : PRINT BLACK
 Fook Key

Installing the Batteries

ATTENTION: Batteries should only be installed by an adult.

The unit comes with batteries already installed. These batteries are meant for in-store demonstration use only, and should be replaced with fresh batteries. To replace the batteries at home, follow these instructions for each blaster:

- 1 Use a Philips screwdriver to open the battery compartment door.
- 2 Install 3 "AA" size batteries into the compartment, making sure that the + and - polarities match the diagram printed inside.
- 3 Close the battery compartment door and tighten the battery door screw. Don't over tighten.

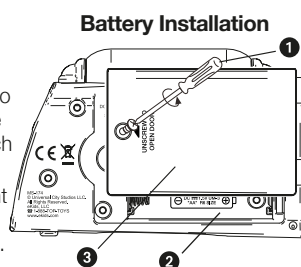

For the Best Possible Performance

- Only use the recommended/supplied batteries or equivalent.
- Use alkaline batteries for longer life.
- Do not mix old and new batteries, and do not mix alkaline, carbon-zinc or rechargeable nickel-cadmium batteries.
- Insert batteries with proper polarity (+/-) as indicated.
- Remove exhausted batteries from product.
- Recharge rechargeable batteries under adult supervision.
- Do not attempt to recharge non-rechargeable batteries.
- Do not open batteries or heat them beyond normal ambient temperatures.
- To prevent battery leakage or damage remove batteries from a product if it will not be used for a month or longer.
- Use extreme caution handling leaking batteries (avoid direct contact with eyes and skin). If battery leakage comes in contact with eyes, IMMEDIATELY flush the eye with lukewarm and gently flowing water for at least 30 minutes. If skin contact occurs, wash skin with clear water for at least 15 minutes. Seek medical attention if any symptoms occur.
- Store in cool, dry, ventilated area away from hazardous or combustible material.
- Do not dispose of batteries in the household trash or fire.
- Follow applicable laws and local regulations for the disposal and transportation of batteries.
- Rechargeable batteries are to be removed from the toy before being charged;
- The supply terminals are not to be short-circuited.
- Do not dispose of batteries in fire; batteries may leak or explode.
- Batteries should be replaced by an adult.
- Remove all packaging before giving to your child.

Troubleshooting

The blasters support a range of approximately 70 feet outdoors and 120 feet indoors. For best performance, aim at your opponent's blaster. Direct sunlight may affect the range and performance of the blasters. Please keep in mind that this product does not transmit well through obstacles such as trees, buildings, and metal structures. If the signal range of the blasters decreases notably, you may have to change your location. If the signal range is still shorter than expected, replace the batteries.

ON/OFF/DEMO Mode

This unit ships in Demo Mode for in-store demonstration purposes. When ready to play, slide the ON/OFF/DEMO Switch to ON Mode.

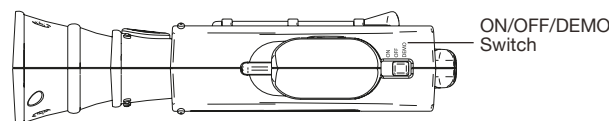

Questions or Comments

For questions or comments regarding this or other eKids products, please call our toll-free number: 1-888-TOP-TOYS. Please also visit our website: www.ekids.com

Maintenance

It is important to keep the unit as dry and clean as possible. Clean the unit with a soft cloth moistened only with mild soap and water. Stronger cleaning agents, such as thinner or similar materials are not recommended, as they may damage the surface of the case.

Limited One-Year Warranty

eKids warrants this product to be free from defects in workmanship and materials, under normal use and conditions, for a period of one (1) year from the date of original purchase.

Should this product fail to function in a satisfactory manner, it is best to first return it to the store where it was originally purchased. Should this fail to resolve the matter and service still be required by reason of any defect or malfunction during the warranty period, eKids will repair or, at its discretion, replace this product without charge. This decision is subject to verification of the defect or malfunction upon delivery of this product to the Factory Service Center authorized by Customer Service. If service is required, please call Customer Service at 1-888-TOP-TOYS (867-8697) to obtain a Return Authorization Number and shipping instructions. A copy of the sales receipt is required to validate in-warranty coverage.

Disclaimer of Warranty

NOTE: This warranty is valid only if the product is used for the purpose for which it was designed. It does not cover (i) products which have been damaged by negligence or willful actions, misuse or accident, or which have been modified or repaired by unauthorized persons; (ii) cracked or broken cabinets, or units damaged by excessive heat; (iii) damage to digital media players, CD's or tape cassettes (if applicable); (iv) the cost of shipping this product to the Factory Service Center and its return to the owner.

This warranty is valid only in the United States of America and does not extend to owners of the product other than to the original purchaser. In no event will eKids or any of its affiliates, contractors, resellers, their officers, directors, shareholders, members or agents be liable to you or any third party for any consequential or incidental damages, any lost profits, actual, exemplary or punitive damages. (Some states do not allow limitations on implied warranties or exclusion of consequential damages, so these restrictions may not apply to you.) This warranty gives you specific legal rights, and you may also have other rights which vary from state to state. Your acknowledgement and agreement to fully and completely abide by the above mentioned disclaimer of warranty is contractually binding to you upon your transfer of currency (money order, cashier's check, or credit card) for purchase of your eKids product.

© 2019 eKids, LLC. All Rights Reserved.
 1299 Main Street Rahway NJ 07065

MODEL: MS-174
 INSTRUCTION MANUAL (FRONT)
 DATE : Sept 13, 2019
 SIZE: 180 L x 230 H mm
 COLOR : PRINT BLACK
 Fook Key

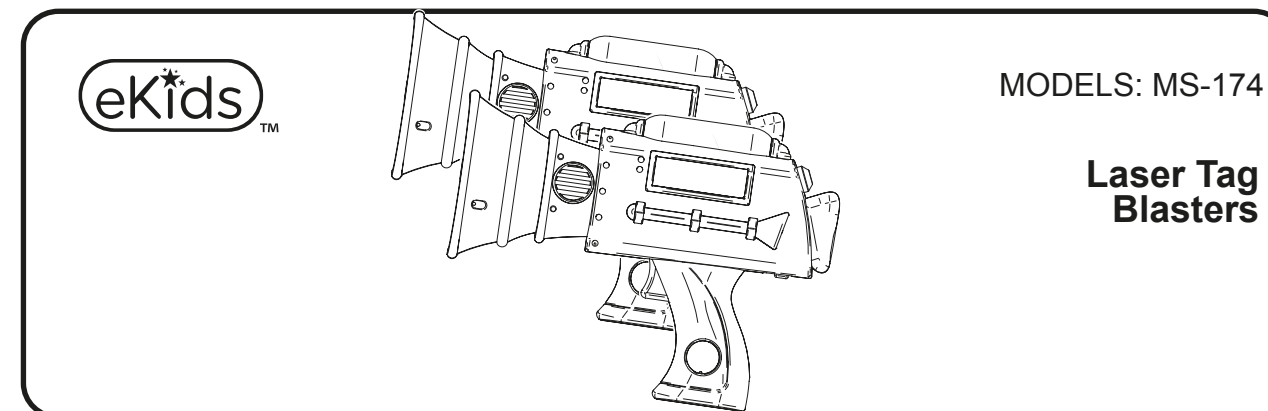

Important Message to Customers

Thank you for purchasing one of our many top-quality electronic products. Please take a moment to read through these instructions to help you understand the safe and proper way to use this toy to extend its usability.

FCC Information

This device complies with Part 15 of the FCC Rules. Operation is subject to the following two conditions: (1) This device may not cause harmful interference, and (2) this device must accept any interference received, including interference that may cause undesired operation.

NOTE: This equipment has been tested and found to comply with the limits for a Class B digital device, pursuant to Part 15 of the FCC Rules. These limits are designed to provide reasonable protection against harmful interference in a residential installation. This equipment generates, uses and can radiate radio frequency energy and, if not installed and used in accordance with the instructions, may cause harmful interference to radio communications. However, there is no guarantee that interference will not occur in a particular installation. If this equipment does cause harmful interference to radio or television reception, which can be determined by turning the equipment off and on, the user is encouraged to try to correct the interference by one or more of the following measures:

- Reorient or relocate the receiving antenna.
- Increase the separation between the equipment and receiver.
- Connect the equipment into an outlet on a circuit different from that to which the receiver is connected.
- Consult the dealer or an experienced radio/TV technician for help.

WARNING: Changes or modifications to this unit not expressly approved by the party responsible for compliance could void the user's authority to operate the equipment.

CAN ICES-3 (B)/NMB-3(B)

Laser Tag Features

LED Indicators

There is an **LED Life Meter** on the top of each blaster that will keep score of shots fired and 'hits' received. When a game begins, each player starts with six 'Life Points'. Each time a player is 'hit', the **LED Damage Indicator** on their blaster will glow, and the **LED Life Meter** will react according to the type of ammo used. View the chart to the right for details.

3 Lights = 6 Life Points 2 Lights = 4 Life Points 1 Blinking Light = 1 Life Point

Switching Ammo

Press and hold the **Reload Button** for 1 second to switch to the next ammo type during game play.

End Game

If a player runs out of Life Points, they are temporarily out of the game. Press and hold the **Reload Button** to reset and start a new game.

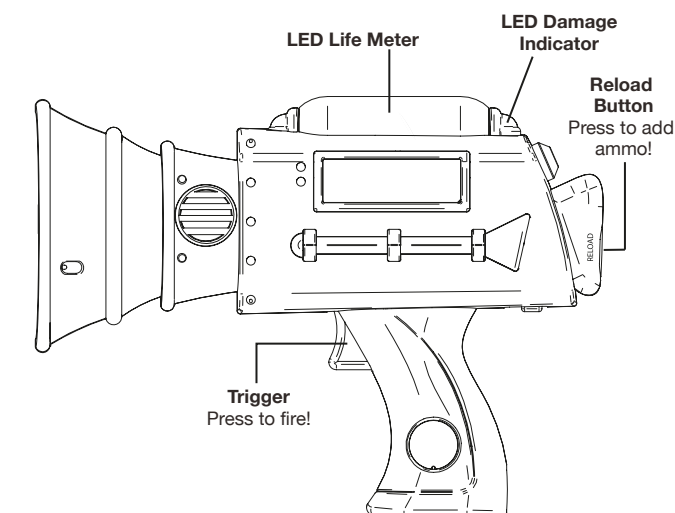

Ammo Type	Shot Power*	Shot Speed	# of Shots**	Reload Time
Single Shot	2 Life Point	Slow	6	Medium
Rapid Shot	1 Life Points	Fast	12	Fast
Big Blast	3 Life Points	Slow	2	Slow

* Number of Life Points taken from opponent after a 'hit'
 ** Number of shots per game for each ammo type