

## INCLUDED ACCESSORIES

Remote control and two AAA batteries

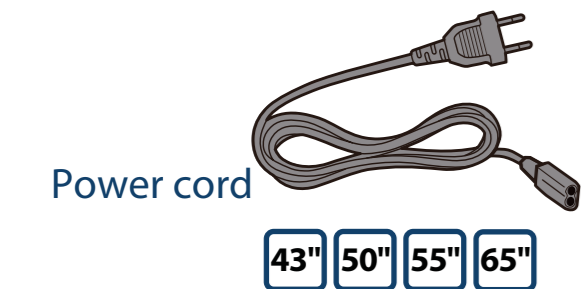

43" 50" 55" 65"

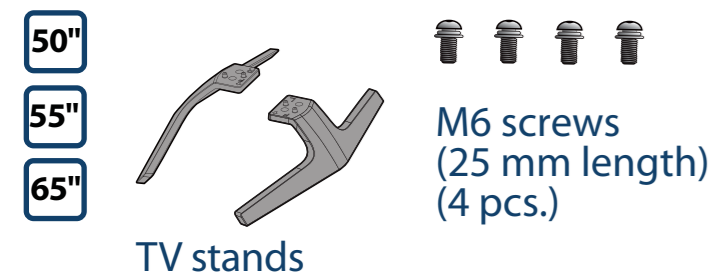
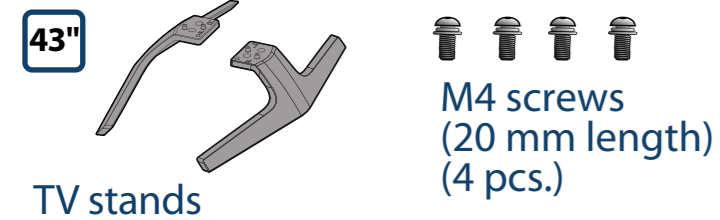

## WHAT YOU NEED (not included)



**FIND YOUR USER GUIDE ONLINE!**  
On a computer, go to [www.insigniaproducts.com](http://www.insigniaproducts.com), enter your model in the search box, then press **ENTER**. Next to *Features*, click **Support & Downloads**, then next to *User Manual*, click the language you want.

**STOP**  
Do not plug your power cord in until all other devices have been connected.

Before using your new product, please read these instructions to prevent any damage.

## 1 START HERE

How do I attach the stand to my TV? (not for wall mounting)

**You'll need:** Soft surface and Phillips screwdriver

**A** Place your TV face-down on a cushioned, clean surface.

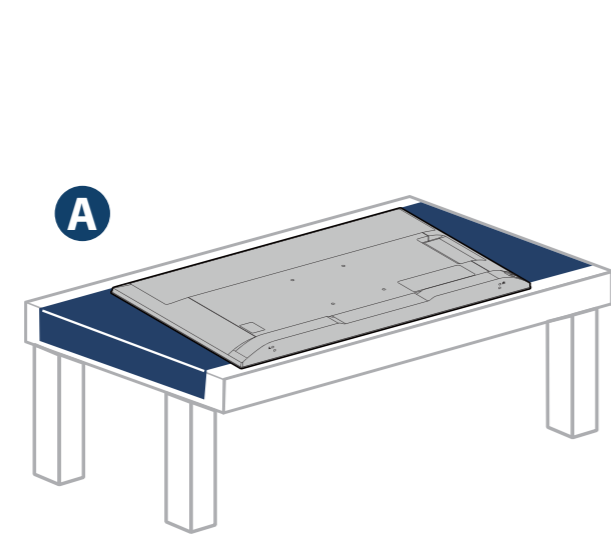

(55" model shown)

**B** Align the screw holes on the TV stands with the holes on the bottom of your TV, then secure each stand to your TV with the provided screws.

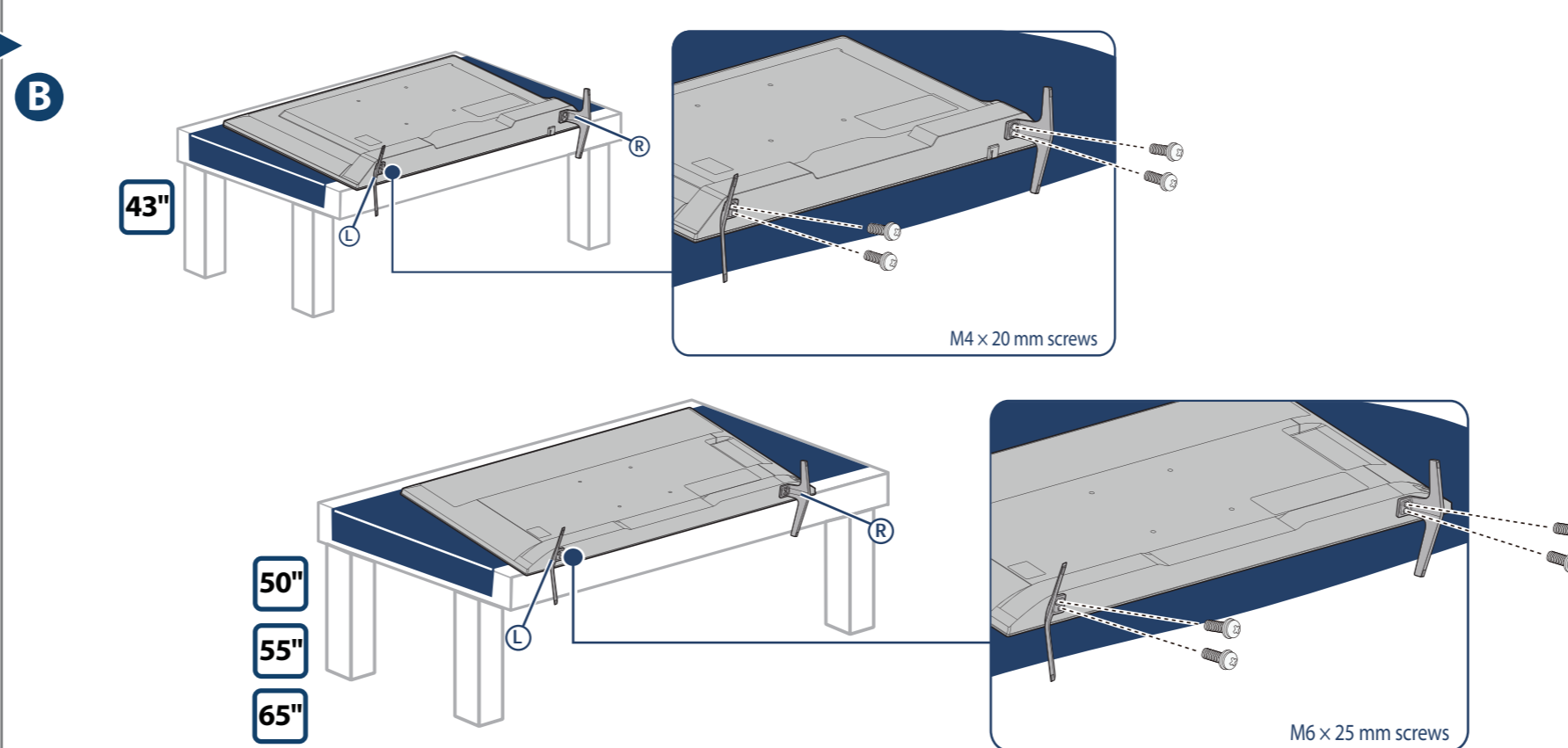

## WALL MOUNT

How do I prepare my TV for wall mounting? (not for use with a TV stand)

**You'll need:** Soft surface and Phillips screwdriver

**OR**

**A** Carefully place your TV face-down on a cushioned, clean surface.  
**B** See the instructions that came with your wall mount for more information about how to correctly mount your TV.  
**C** Your TV has wall-mount screws installed in the VESA mounting holes on the back of your TV. Remove the screws, place the wall-mount bracket (not included) over the screws holes, then replace the screws to secure the bracket to your TV.

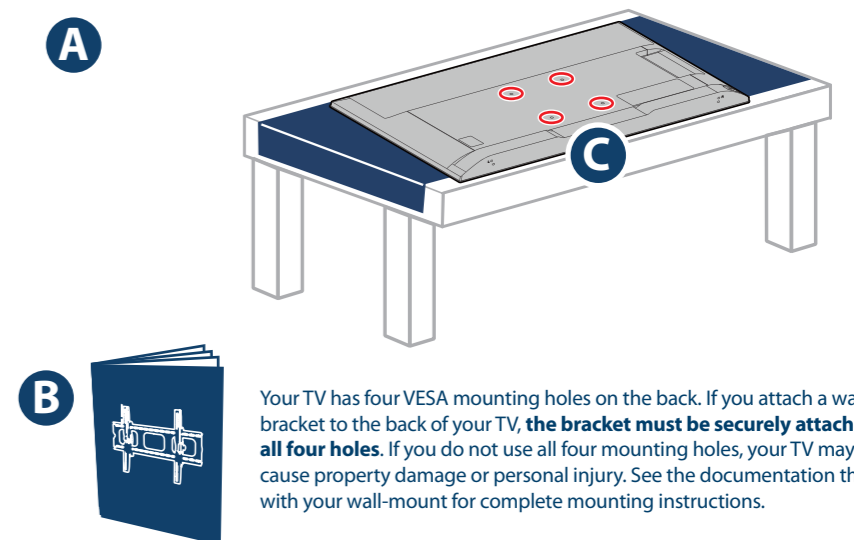

## FEATURES

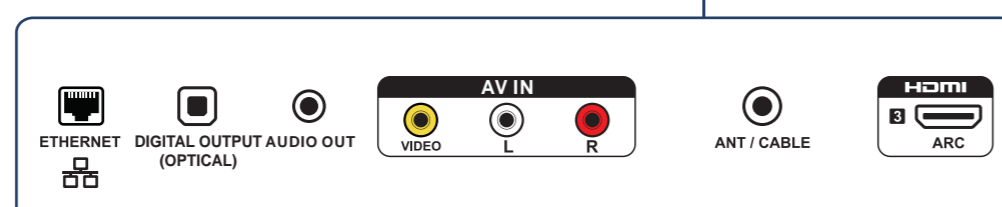
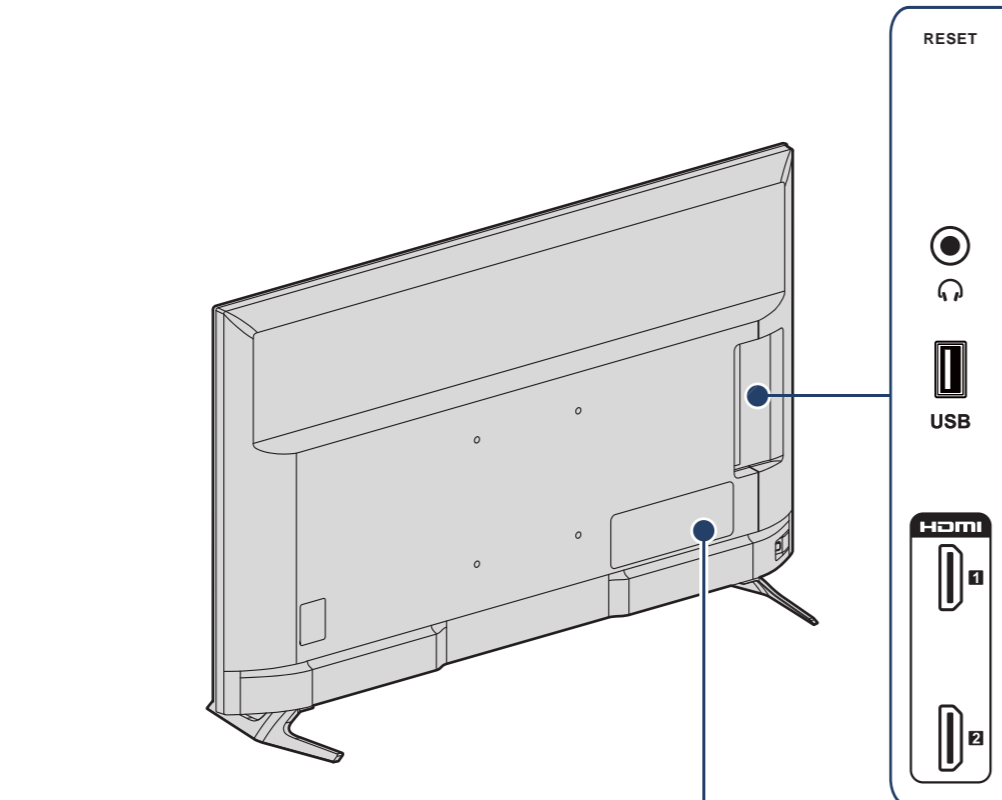

## 2 MAKING CONNECTIONS

How do I watch TV (cable, satellite, or antenna) or connect a device, such as a DVD or Blu-ray disc player, game console, or tablet?

### WHICH CABLES DO YOU HAVE?

**HDMI (BEST)**  
Best video quality

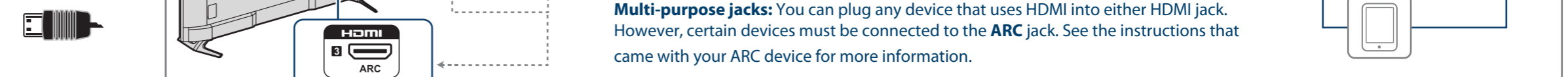

**AV (GOOD)**

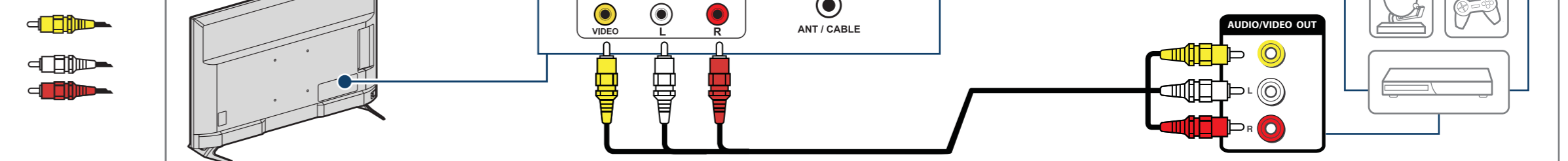

**COAXIAL (GOOD)**



## 3 CONNECTING AUDIO DEVICES

How do I connect my TV to external speakers?

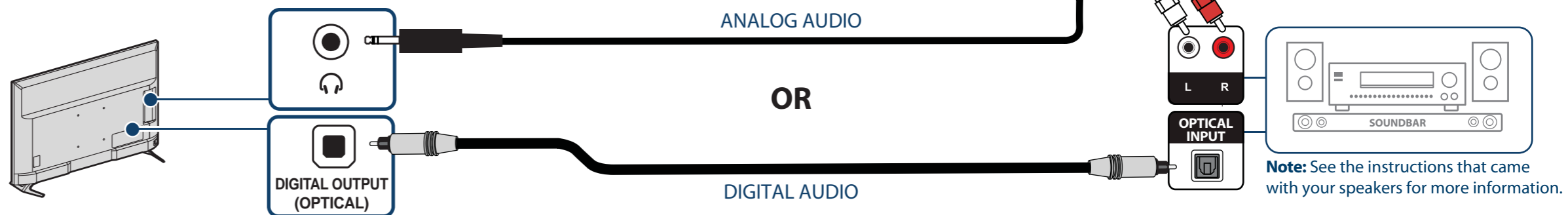



## 4 TURNING ON MY TV

When can I turn on my TV?

### WHEN YOUR TV IS IN PLACE:

- 1 Plug the power cord into the **AC IN** jack on the back of your TV, then plug the other end into a power outlet.
- 2 Remove the remote control cover and install the batteries.
- 3 Press  (power) on your remote control.
- 4 Follow the on-screen instructions.

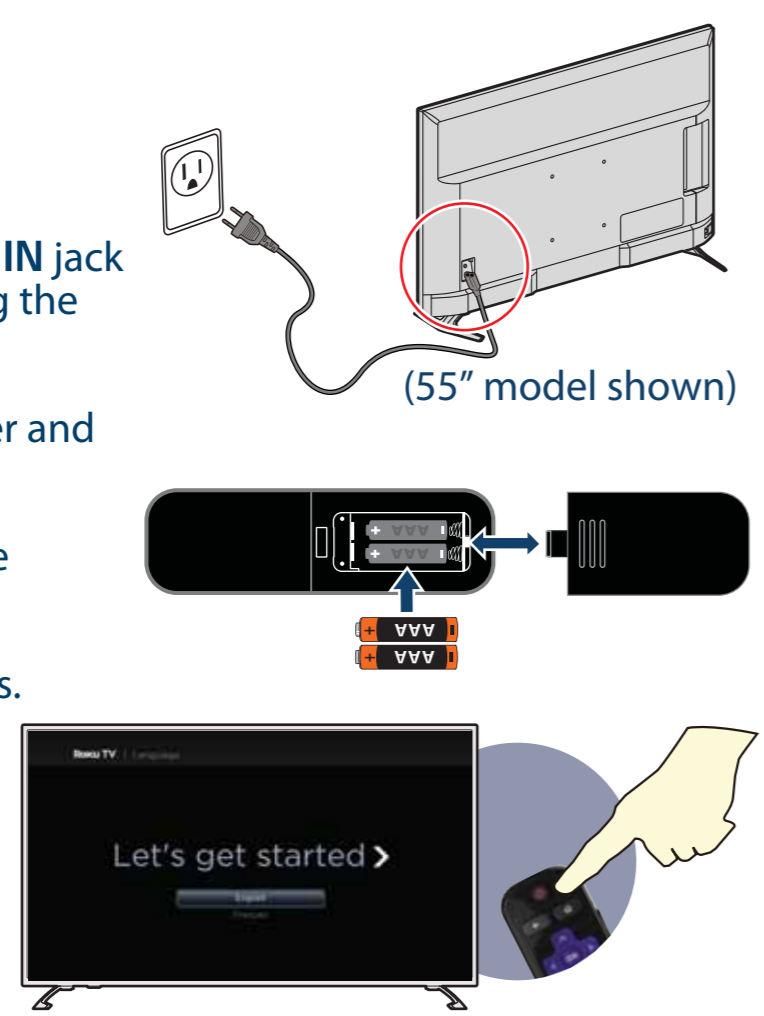

## 5 COMPLETE GUIDED SETUP (OPTIONAL)

Establish your network connection.

- 1 Your TV automatically detects your wireless network, so have your network name and password handy and follow the easy on-screen instructions.
- 2 You'll be prompted to create your Roku account online at <https://my.roku.com/link>. Your TV will generate a unique code that links your TV to your new account.
- 3 **Note:** Roku accounts are free, and while a valid credit card number is not required, providing your card information makes renting and purchasing entertainment a breeze.
- 4 Once connected to your account, your TV will automatically update with the latest software, and you can start streaming immediately.
- 5 If you aren't ready to connect your TV to a wireless network, you can still use it as a regular TV.

## 6 OPTIONAL

Watching local broadcast TV  
How do I scan for channels?

If you connected a cable or satellite box, skip this step.

If you connected your TV to an antenna or cable wall jack (no box):

- 1 When the setup wizard is complete, select the **ANTENNA TV** tile  from the Home screen.
- 2 Follow the on-screen instructions.
- 3 Whenever you want to watch local broadcast TV, select this tile.



## CONNECTING BRINGS OUT YOUR TV'S FULL POTENTIAL!

You'll have access to more than thousands of streaming channels\*.



**Make any night a movie night**  
Access more than 450,000 movies and TV episodes across major streaming services like Netflix, Hulu, Amazon Video, VUDU, and more. Choose from free, rental, and subscription services.\*

**Stream sports on the big screen.**  
Choose from over 140 sports channels like Watch ESPN, FOX Sports Go, NBA, NFL, MLB, WWE, CBS Sports, and more.\*

**Explore your passions**  
In addition to popular streaming channels like HBO NOW, SHOWTIME, PBS KIDS, and FOX NOW, your Insignia • Roku TV also offers hundreds of streaming channels to fuel your passions – including fitness, cooking, religion, outdoors, international programming, and much more.

**Enjoy tons of free channels and free trials**  
Your Insignia Roku TV has hundreds of popular free channels like Crackle, CBS News, PBS, VEVO, and more. Plus, free trials\*\* to popular subscription services like HBO NOW, SHOWTIME, Netflix, Amazon Video, and Hulu.

\*Subscription or other payment may be required to access certain channels. Content may not be available in all areas in which the Insignia Roku TVs are sold and channel availability is subject to change.

\*\*Cancel before your free trial ends to avoid subscription fees. Credit card may be required.

ROKU, ROKU TV, and the ROKU logo are trademarks and the property of Roku, Inc. Other channel logos, brand, and product names are trademarks or registered trademarks of their respective holders.

## USING YOUR REMOTE CONTROL

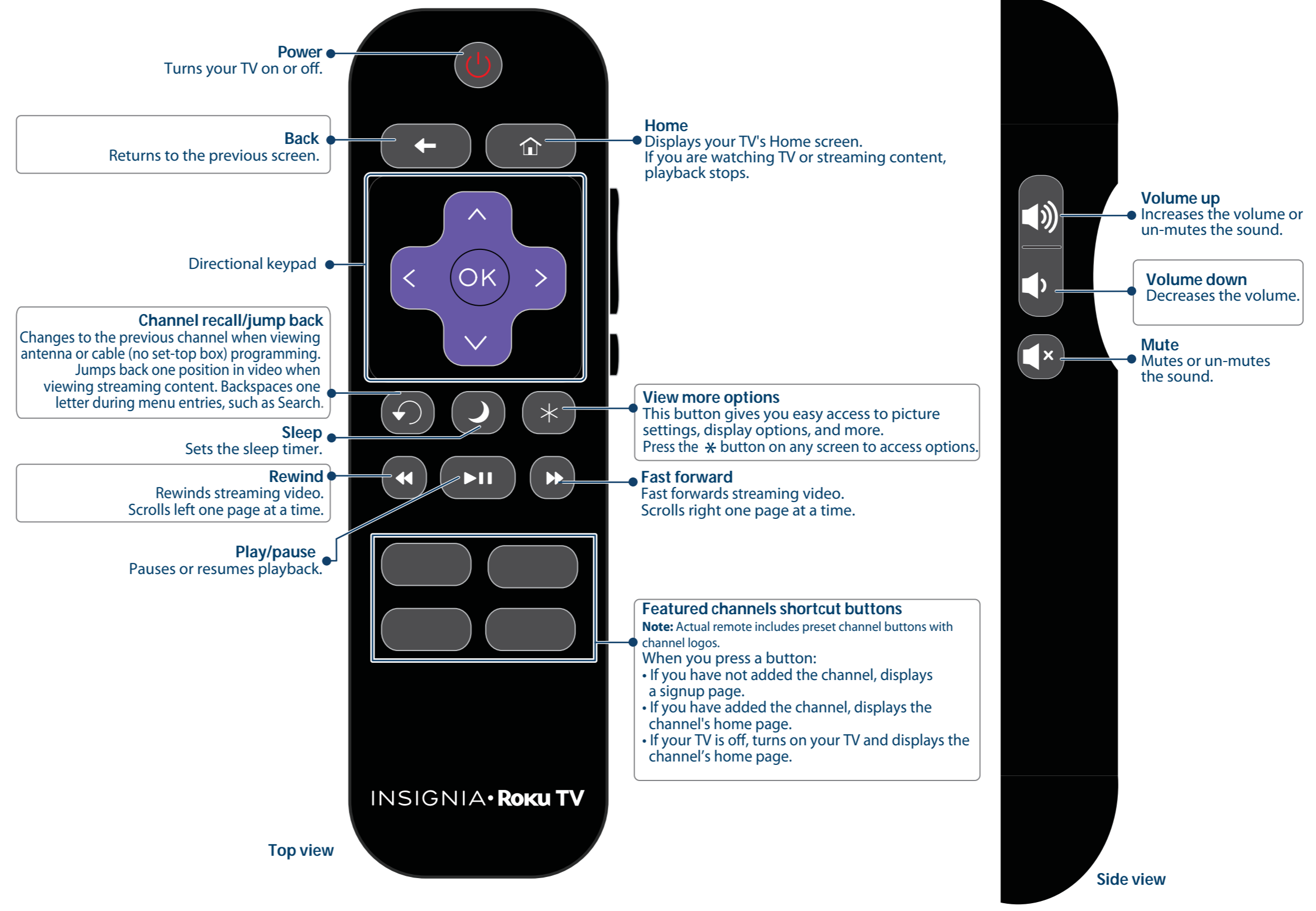

**Using your Cable Set-top Box or Satellite Receiver Remote as a universal remote.**  
If you prefer to use your cable set-top box or satellite receiver remote as a Universal Remote, please refer to the manual that your cable or satellite service provided. It includes instructions on how to program their remote to your television. You can find codes that work with your Insignia • Roku TV and the most common cable and satellite providers' universal remote controls at [www.roku.com/universalremote](http://www.roku.com/universalremote).

## INSIGNIA • Roku TV

### TROUBLESHOOTING

**Having trouble completing the guided setup?**  
**Don't worry, it's usually an easy fix.**  
**If you cannot see a picture on your TV:**

- Make sure your TV and the device you want to watch (cable box, Blu-ray player, game console, etc.) are turned on and plugged into a working wall outlet.
- Make sure your power cable is connected.

**If you cannot connect to your wireless home network during guided setup**

- Make sure the correct wireless network name is selected.
- Make sure the wireless network password is correctly entered (password is case sensitive).
- Improve wireless signal by rotating the router slightly (even a few inches can help).

**If you cannot hear sound:**

- Make sure TV volume is turned up and not on mute.
- Try only the TV speakers by disconnecting any connection to audio devices (like headphones or audio video receivers).

**If the TV remote control isn't working:**

- Remove any obstruction and point the remote at the TV's remote control sensor (FEATURES).
- Try a fresh set of batteries.
- If the status light on the front of your TV flashes once each time you press a remote button, the problem is not with the remote.
- Unplug the TV and plug it back in.

**ONE-YEAR LIMITED WARRANTY**  
Visit [www.insigniaproducts.com](http://www.insigniaproducts.com) for details.

**NEED ADDITIONAL HELP?**  
See your online **User Guide!** This comprehensive guide includes everything from basic how-to steps to more advanced features. A copy of your **User Guide** is not provided in the box but is available online.  
**FIND YOUR USER GUIDE ONLINE!**  
On a computer, go to [www.insigniaproducts.com](http://www.insigniaproducts.com), enter your model in the search box, then press **ENTER**. Next to **Features**, click **Support & Downloads**, then next to User Manual, click the language you want.

Check out our **Support Community** <http://community.insigniaproducts.com/> for helpful information from other Insignia TV owners.

**WE'RE HERE FOR YOU**  
[www.insigniaproducts.com](http://www.insigniaproducts.com)  
For customer service, call: **877-467-4289** (U.S./Canada)

INSIGNIA is a trademark of Best Buy and its affiliated companies  
Distributed by Best Buy Purchasing, LLC  
7601 Penn Ave South, Richfield, MN 55423 U.S.A.  
©2017 Best Buy. All rights reserved  
**Made in China**