

Job Name:	
Submitted By:	



Submittal Sheet For: FB018GMSILDFHG / YN018GMSI24RPG

Date _____
 Ref. _____

Floor-Mounted Console 24SEER Inverter Heat Pump

System Full Set Model: **FYB018GMSI24RL**

AHRI Reference Number: **218010990**

Cooling Mode Performance

Rated Cooling	16,000 BTU/hr
Ambient Range	5~131°F
SEER2 Rating	23.8 BTU/W·h
EER2 Rating	12.5 BTU/W·h

* 100% Capacity @ Indoor DB 80°F / WB 67°F

Heating Mode Performance

Rated Heating	17,000 BTU/hr
Ambient Range	-13~86°F
HSPF2 IV (V)	13.5 (9.4) BTU/W·h
COP2 (47°F)	3.4 W/W

Heating (17°F) = 14,100 BTU / Heating (5°F) = 13,100 BTU / COP2 (5°F) = 2.16 W/W



Floor-Mounted Indoor Unit



Outdoor Condensing Unit



User-Selected Installation Kit



Handheld Remote Controller

Electrical Information

Rated Input (W)	Cooling	Heating
	1,280	1,478
Rated Current (A)	5.8	6.7
Breaker Needed	20A (Double-Pole)	
Power Supply	208~230V, 60Hz, 1Ph	

Piping and Refrigerant

Liquid Line (OD)	1/4 in
Suction Line (OD)	1/2 in
Refrigerant Precharge	R-454b(Supports 10-50 ft.)
Max Length/Height Diff.	65 ft. / 50 ft.

This combination is Energy-Star certified.



Interior Unit (Air Handler) Specifications

Type	Heat Pump
Sound Level (dBA)	41.5 (Hi) / 39 (Med) / 28.5 (Lo)
Auto Air Circulation	2 Air Outlets / 4 Air Inlets
Dimensions (WDH)	31-1/4 in x 7-7/8 in x 24-1/2 in
Weight (lbs)	32.9

Exterior Unit (Condenser) Specifications

Sound Level (dBA)	57
Recommended Room Size	500~750 Sq. ft.
Minimum Room Size	227 Sq. ft.
Compressor	Inverter-Driven Rotary
Dimensions (WDH)	35 in x 13-1/2 in x 26-1/2 in
Weight (lbs)	92.6

All dimensions are in Inches (mm)

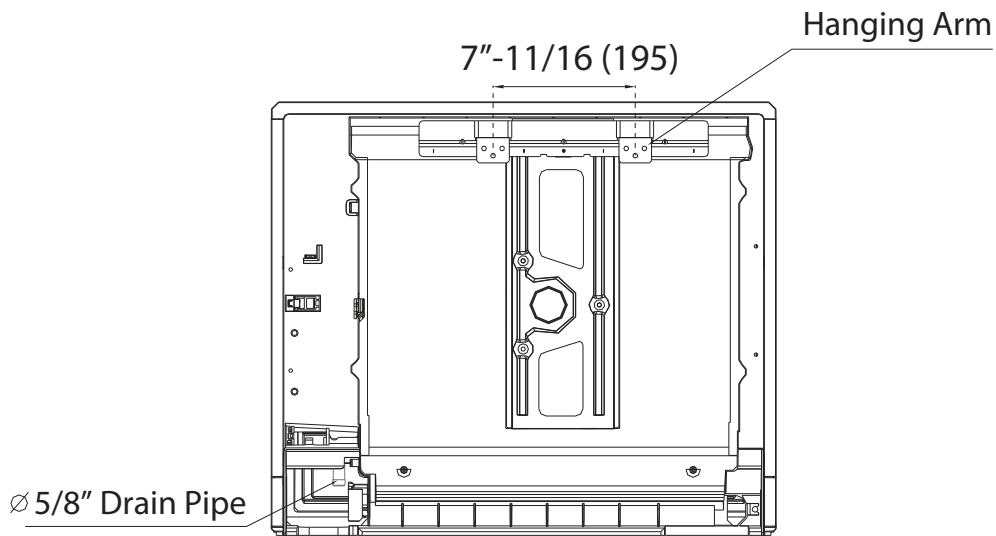
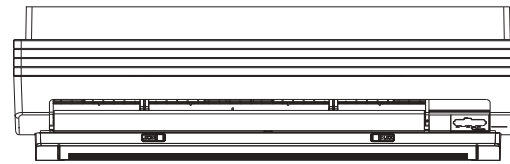
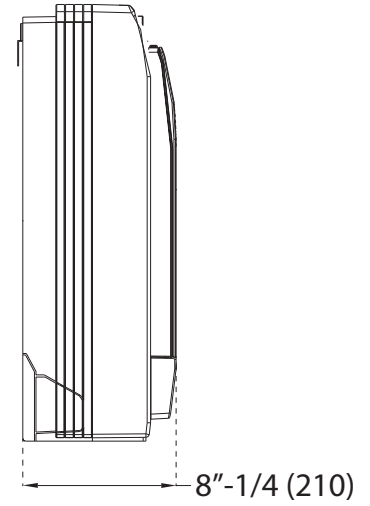
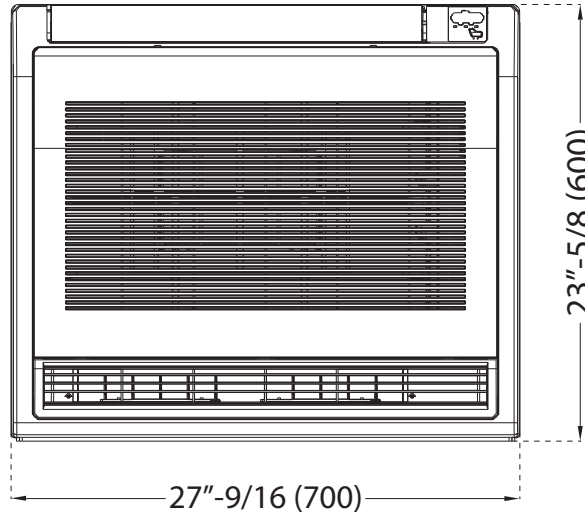
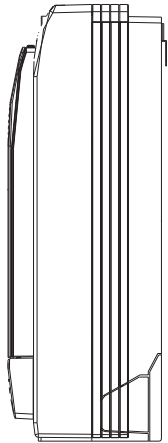
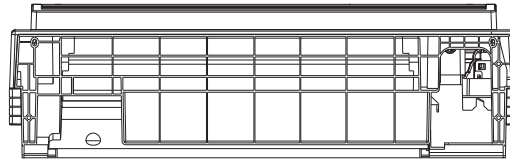

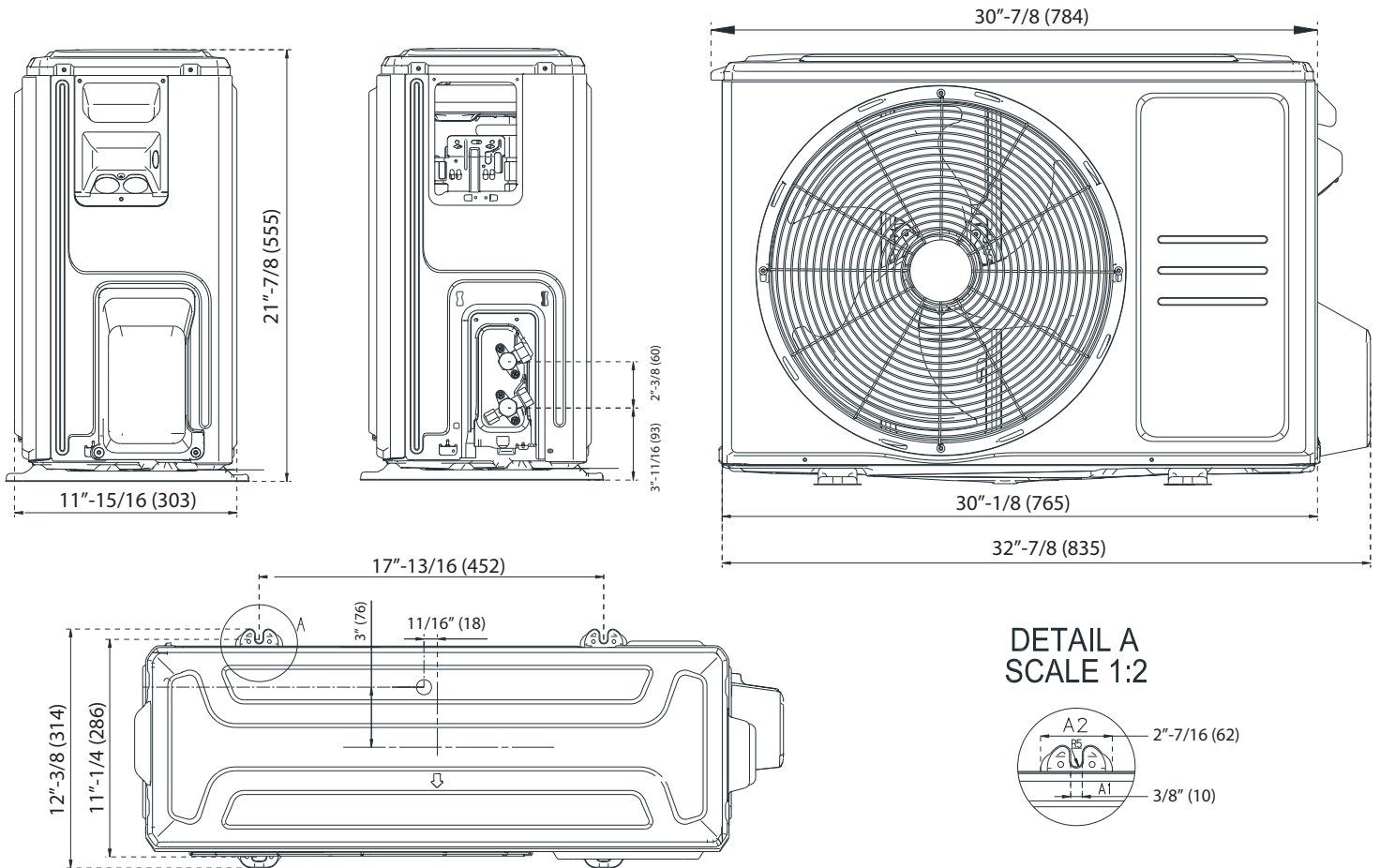

Warranty Information and Length



Complete warranty details are available with the vendor or online at <https://www.pdhvac.com/support/warranty/>. This high quality system is eligible for up to 10 years limited warranty on the compressor, and 7 years on other internal parts. To qualify for this warranty, the system must be installed within 90 days by a registered technician. All other installations that are registered default to 5 years parts/compressor. Products unregistered qualify for only 1 year parts/compressor warranty.

Outstanding Features

- LED Display
- Energy Saving
- Ultra-Thin Design
- Dual Drain Options
- Customizable Timer
- Eco-Friendly Refrigerant
- Whisper-Quiet Operation
- Power Loss Memory Recovery



Available Accessories

Part Number	Description
IKT-LCVR4P-KIT	Decorative PVC Line Cover Kit
IKT-LNBR-1/4-3/8	BendAid Flexible Easy Bender Kit
BRK-FRM-C-2P	Folding Mounting Bracket w/ Leveler
IKT-UVL32UL-AG	UVC Bacterial Disinfection Kit
IKT-SURPRK-DV2	Ultimate Surge and Power Protection