

Job Name:	
Submitted By:	



Submittal Sheet For: **FB012GMSILDFHG / YN012GMSI24RPG**

Date _____
 Ref. _____

Floor-Mounted Console 24SEER Inverter Heat Pump

System Full Set Model: **FYB012GMSI24RL**

AHRI Reference Number: **218010989**

Cooling Mode Performance

Rated Cooling	12,000 BTU/hr
Ambient Range	5~131°F
SEER2 Rating	24.6 BTU/W·h
EER2 Rating	12.7 BTU/W·h

* 100% Capacity @ Indoor DB 80°F / WB 67°F

Heating Mode Performance

Rated Heating	12,000 BTU/hr
Ambient Range	-13~86°F
HSPF2 IV (V)	11.0 (8.2) BTU/W·h
COP2 (47°F)	3.9 W/W

Heating (17°F) = 9,000 BTU / Heating (5°F) = 8,900 BTU / COP2 (5°F) = 2.5 W/W



Floor-Mounted Indoor Unit



Outdoor Condensing Unit



User-Selected Installation Kit



Handheld Remote Controller

Electrical Information

	Cooling	Heating
Rated Input (W)	960	897
Rated Current (A)	4.2	4.0
Breaker Needed	15A (Double-Pole)	
Power Supply	208~230V, 60Hz, 1Ph	

Piping and Refrigerant

Liquid Line (OD)	1/4 in
Suction Line (OD)	3/8 in
Refrigerant Precharge	R-454b(Supports 10-50 ft.)
Max Length/Height Diff.	50 ft. / 33 ft.

This combination is Energy-Star certified.



Interior Unit (Air Handler) Specifications

Type	Heat Pump
Sound Level (dBA)	39 (Hi) / 34.5 (Med) / 29.5 (Lo)
Auto Air Circulation	2 Air Outlets / 4 Air Inlets
Dimensions (WDH)	31-1/4 in x 7-7/8 in x 24-1/2 in
Weight (lbs)	32.9

Exterior Unit (Condenser) Specifications

Sound Level (dBA)	55
Recommended Room Size	350~500 Sq. ft.
Minimum Room Size	154 Sq. ft.
Compressor	Inverter-Driven Rotary
Dimensions (WDH)	30-1/8 in x 12 in x 21-7/8 in
Weight (lbs)	62.1

All dimensions are in Inches (mm)

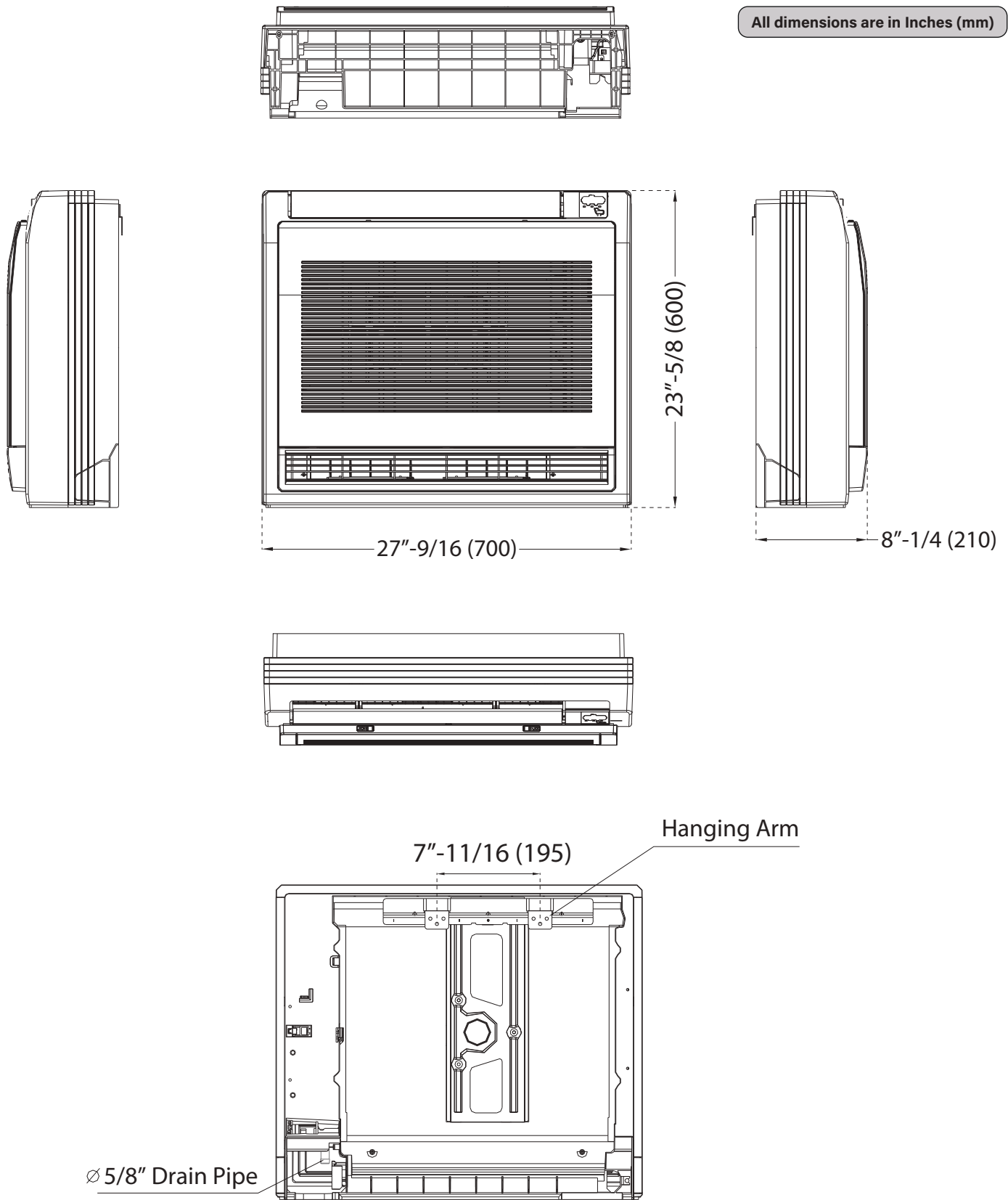

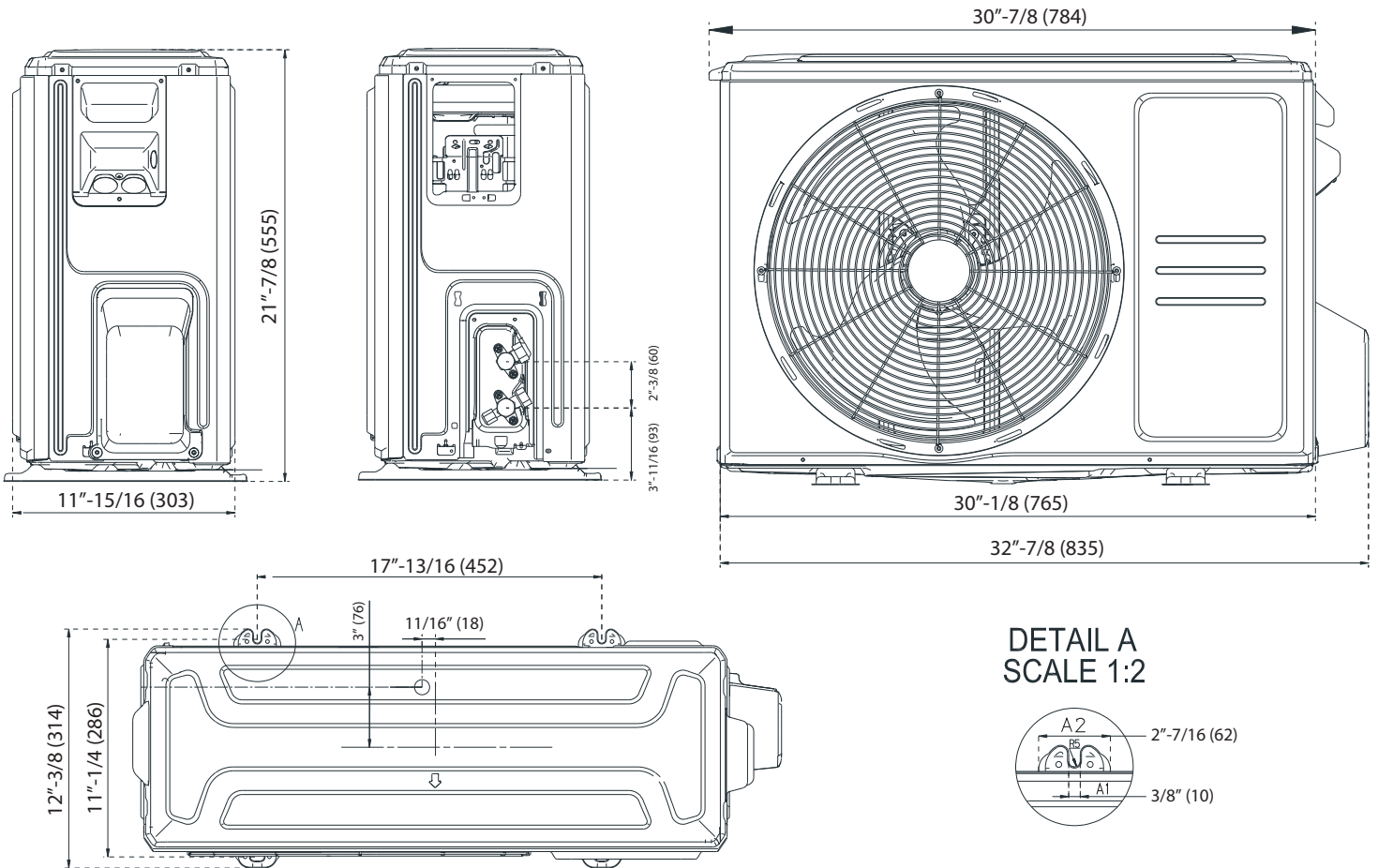

Warranty Information and Length



Complete warranty details are available with the vendor or online at <https://www.pdhvac.com/support/warranty/>. This high quality system is eligible for up to 10 years limited warranty on the compressor, and 7 years on other internal parts. To qualify for this warranty, the system must be installed within 90 days by a registered technician. All other installations that are registered default to 5 years parts/compressor. Products unregistered qualify for only 1 year parts/compressor warranty.

Outstanding Features

- LED Display
- Energy Saving
- Ultra-Thin Design
- Dual Drain Options
- Customizable Timer
- Eco-Friendly Refrigerant
- Whisper-Quiet Operation
- Power Loss Memory Recovery



Available Accessories

Part Number	Description
IKT-LCVR4P-KIT	Decorative PVC Line Cover Kit
IKT-LNBR-1/4-3/8	BendAid Flexible Easy Bender Kit
BRK-FRM-C-2P	Folding Mounting Bracket w/ Leveler
IKT-UVL32UL-AG	UVC Bacterial Disinfection Kit
IKT-SURPRK-DV2	Ultimate Surge and Power Protection