

netvue

User Manual

Peekababy Baby Camera

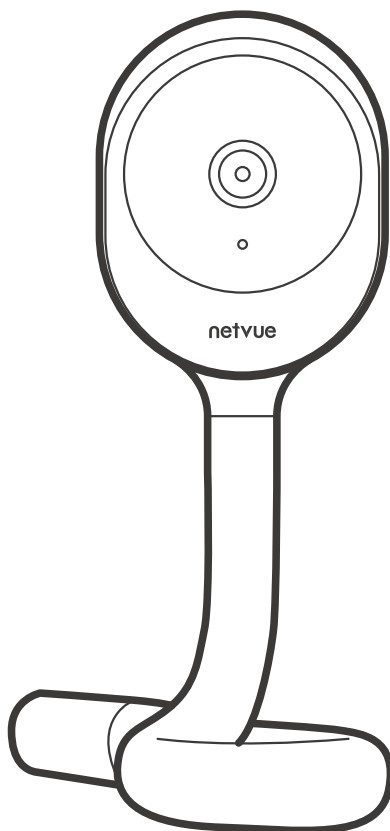

EN

ES

FR

DE

IT

Warning



Warning--Strangulation Hazard--Children have STRANGLED in cords. Always use protective covering when used within 3 feet of crib. Check before each use to ensure that the cord is not exposed to your child. Immediately discontinue use if protective covering is damaged or broken. Do not remove this tag.

Warning--Strangulation Hazard--Children have STRANGLED in cords. When using without protective covering, keep this cord out of the reach of children (more than 3ft (0.9 m) away). Do not remove this tag.



Keep away from fire.

Von Feuer fernhalten.

Tenir à l'écart du feu.

Tenere lontano dal fuoco.

Mantener alejado del fuego.

Read Before Installing

1. Keep Peekababy and all accessories out of the reach of children and pets.
2. Use the provided charger or a standard charger and cable (DC5V / 1A); otherwise, it may trigger overload or low voltage protection, preventing proper charging.
3. Ensure the device is within the range of your Wi-Fi signal.
4. Working temperature: 0°C to 40°C (32°F to 104°F). Working relative humidity: 0-95%.
5. Keep the camera away from appliances such as heaters or humidifiers, as close proximity may affect temperature and humidity readings.
6. Avoid placing the camera behind furniture or near a microwave oven.

Leer antes de instalar

1. Mantenga Peekababy y todos los accesorios fuera del alcance de los niños y las mascotas.
2. Use el cargador proporcionado o un cargador y cable estándar (DC5V / 1A); de lo contrario, puede activar la protección contra sobrecarga o baja tensión, lo que impedirá la carga adecuada.
3. Asegúrese de que el dispositivo esté dentro del alcance de la señal Wi-Fi.
4. Temperatura de funcionamiento: 0°C a 40°C. Humedad relativa de trabajo: 0-95%.
5. Mantenga la cámara alejada de aparatos como calentadores o humidificadores, ya que la proximidad puede afectar las lecturas de temperatura y humedad.

6. Evite colocar la cámara detrás de muebles o cerca de un horno microondas.

Lire avant l'installation

1. Gardez Peekababy et tous les accessoires hors de portée des enfants et des animaux domestiques.
2. Utilisez le chargeur fourni ou un chargeur et un câble standard (DC5V / 1A); sinon, cela pourrait déclencher une surcharge ou une protection contre les basses tensions, empêchant une charge correcte.
3. Assurez-vous que l'appareil est à portée de votre signal Wi-Fi.
4. Température de fonctionnement : 0°C à 40°C. Humidité relative de fonctionnement : 0-95%.
5. Gardez la caméra éloignée des appareils comme les radiateurs ou les humidificateurs, car une proximité peut affecter les relevés de température et d'humidité.
6. Évitez de placer la caméra derrière des meubles ou près d'un four à micro-ondes.

Vor der Installation lesen

1. Halten Sie Peekababy und alle Zubehörteile außerhalb der Reichweite von Kindern und Haustieren.
2. Verwenden Sie das mitgelieferte Ladegerät oder ein Standardladegerät und Kabel (DC5V / 1A); andernfalls kann eine Überlastung oder ein Niederspannungsschutz ausgelöst werden, was das ordnungsgemäße Laden verhindert.
3. Stellen Sie sicher, dass sich das Gerät im Bereich Ihres WLAN-Signals befindet.

4. Betriebstemperatur: 0°C bis 40°C. Betriebliche relative Luftfeuchtigkeit: 0-95%.
5. Halten Sie die Kamera von Geräten wie Heizgeräten oder Luftbefeuchtern fern, da diese die Temperatur- und Feuchtigkeitsmessungen beeinträchtigen können.
6. Vermeiden Sie es, die Kamera hinter Möbeln oder in der Nähe eines Mikrowellenofens zu platzieren.

Leggere prima di installare

1. Tenere Peekababy e tutti gli accessori fuori dalla portata di bambini e animali domestici.
2. Utilizzare il caricatore fornito o un caricatore e un cavo standard (DC5V / 1A); in caso contrario, potrebbe attivarsi la protezione da sovraccarico o bassa tensione, impedendo la corretta carica.
3. Assicurarsi che il dispositivo sia entro la portata del segnale Wi-Fi.
4. Temperatura di funzionamento: 0°C - 40°C. Umidità relativa di funzionamento: 0-95%.
5. Tenere la telecamera lontana da elettrodomestici come riscaldatori o umidificatori, poiché la vicinanza potrebbe influenzare le letture di temperatura e umidità.
6. Evitare di posizionare la telecamera dietro mobili o vicino a forni a microonde.

Catalog

What's in the Box	1-3
About the Product	4-5
Status Light	6-8
Common Settings	9-14
Cloud Services	15-16
Warning	17-19
Contact Us	20-21

Catálogo

Qué hay en la caja	1-3
Acerca del producto	4-5
Luz de estado	6-8
Configuraciones comunes	9-14
Servicio en la nube	15-16
Advertencia	17-19
Contáctenos	20-21

Catalogue

Contenu de la boîte	1-3
À propos du produit	4-5
Voyant d'état	6-8
Paramètres courants	9-14
Service cloud	15-16
Avertissement	17-19
Contactez-nous	20-21

Katalog

Was ist in der Box	1-3
Über das Produkt	4-5
Statusleuchte	6-8
Allgemeine Einstellungen	9-14
Cloud-Dienst	15-16
Warnung	17-19
Kontaktieren Sie uns	20-21

Catalogo

Cosa c'è nella scatola	1-3
Informazioni sul prodotto	4-5
Spia di stato	6-8
Impostazioni comuni	9-14
Servizio cloud	15-16
Avvertenze	17-19
Contattaci	20-21

What's in the Box

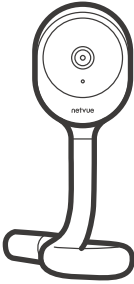

Camera
Cámara
Caméra
Kamera
Telecamera

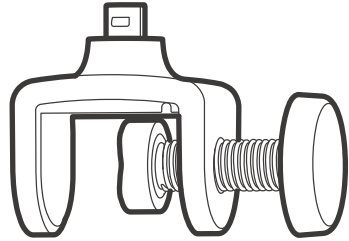

Mounting clamp
Abrazadera de montaje
Pince de montage
Befestigungsklammer
Morsetto di montaggio



Mounting pole
Poste de montaje
Poteau de montage
Befestigungspol
Palo di montaggio



Extension pole
Poste de extensión
Poteau d'extension
Verlängerungspol
Palo di prolunga



Disassembly tool

Herramienta de desmontaje

Outil de démontage

Demontagewerkzeug

Strumento di smontaggio



Wall-mount box

Caja de montaje en pared

Boîte de montage mural

Wandmontagebox

Scatola a parete

Wall-mount screw kit

Kit de tornillos para montaje en pared

Kit de vis pour montage mural

Wandmontage-Schraubenset

Kit viti per montaggio a parete

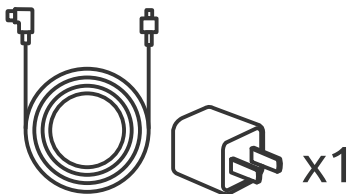
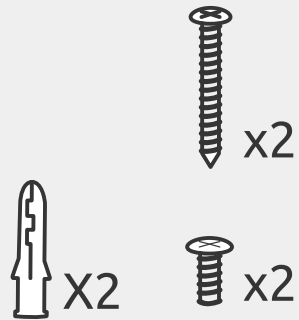

Cable & adapter x 1

Cable y adaptador x 1

Câble & adaptateur x 1

Kabel & Adapter x 1

Cavo e adattatore x 1

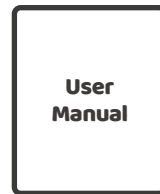

User Manual

Manual del usuario

Manuel de l'utilisateur

Benutzerhandbuch

Manuale utente



Quick Start Guide

Guía de inicio rápido

Guide de démarrage rapide

Schnellstartanleitung

Guida rapida

About the Product

Camera Structure

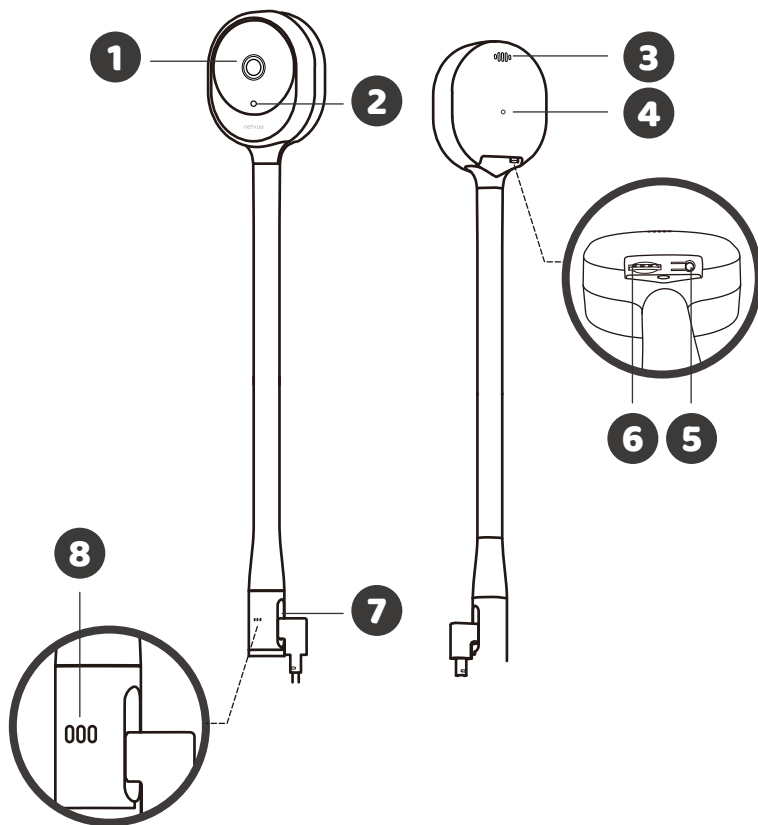

- 1** Lens
Lente
Objectif
Linse
Obiettivo

- 2** Microphone
Micrófono
Microphone
Mikrofon
Microfono

- 3** Speaker
Altavoz
Haut-parleur
Lautsprecher
Altoparlante
- 4** Status light
Luz de estado
Le voyant d'état
Statusleuchte
Luce di stato
- 5** Config button
Botón Config
Bouton config
Konfigurationstaste
Pulsante config
- 6** MicroSD card slot
Ranura microSD
Emplacement microSD
MicroSD-Kartensteckplatz
Slot microSD
- 7** Charging port
Puerto de carga
Port de charge
Ladeanschluss
Porta di ricarica
- 8** Temp / RH sensor
Sensor Temp / RH
Capteur temp / RH
Temperatur- / RH-Sensor
Sensore Temp / RH

Status Light

Operation	Light	Description	Sound
No Power	None	Powered-Off	-
Power Connected	Solid Red	Powered On, Not Paired Yet	Start-Up Tone
Long Press Config Button	Flashing Red	Waiting for Monitor Pairing*	-
Press Config Button Briefly	Flashing Yellow	Waiting for App Pairing	Periodic Chimes
-	Solid Yellow	Camera Online	-

*This product set does not include a monitor.

Operación	Luz	Descripción	Sonido
Sin alimentación	Ninguna	Apagada	-
Alimentación conectada	Rojo fijo	Encendida, no emparejada aún	Tono de inicio
Presionar Config prolongadamente	Parpadeo rojo	Esperando emparejamiento con el monitor*	-
Presionar Config brevemente	Parpadeo amarillo	Esperando emparejamiento con la app	Tono periódico
-	Amarillo fijo	Cámara en línea	-

*Este conjunto de productos no incluye un monitor.

Operación	Luz	Descripción	Sonido
Pas d'alimentation	Aucune	Hors tension	-
Alimentation connectée	Rouge fixe	Allumée, non encore appairée	Ton de démarrage
Appuyer longuement sur Config	Clignotement rouge	En attente d'appairage avec le moniteur*	-
Appuyer brièvement sur Config	Clignotement jaune	En attente d'appairage avec l'application	Carillons périodiques
-	Jaune fixe	Caméra en ligne	-

*Cet ensemble de produits n'inclut pas de moniteur.

Betrieb	Licht	Beschreibung	Ton
Keine Stromversorgung	Keine	Ausgeschaltet	-
Strom angeschlossen	Dauerrot	Eingeschaltet, noch nicht gekoppelt	Start-Ton
Lange Konfig-Taste drücken	Blinkend Rot	Wartet auf Monitorkopplung*	-
Kurze Konfig-Taste drücken	Blinkend Gelb	Wartet auf App-Kopplung	Periodische Signaltöne
-	Dauerhaft Gelb	Kamera online	-

*Dieses Produktset enthält keinen Monitor.

Operazione	Luce	Descrizione	Suono
Nessuna alimentazione	Nessuna	Spento	-
Alimentazione collegata	Rosso fisso	Acceso, non ancora associato	Suono di avvio
Premere a lungo Config	Lampeggiante Rosso	In attesa di accoppiamento monitor*	-
Premere brevemente Config	Lampeggiante Giallo	In attesa di accoppiamento app	Segnali acustici periodici
-	Giallo fisso	Telecamera online	-

*Questo set di prodotti non include un monitor.

Common Settings

How to Power On & Off the Camera

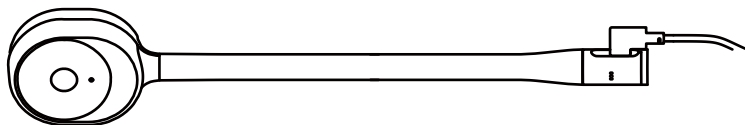

1. Simply plug in or unplug the power cable to turn the camera on or off; no buttons are required.
2. The camera does not have a built-in battery and must be connected to power at all times during use.

Notes:

1. Please use the provided charger or a standard charger (DC5V / 1A) and charging cable. Using other chargers may trigger overload or low voltage protection, preventing charging.
2. If you experience charging issues, please contact customer support: support@netvue.com

1. Simplemente conecte o desconecte el cable de alimentación para encender o apagar la cámara; no se requieren botones.
2. La cámara no tiene una batería incorporada y debe estar conectada a la corriente en todo momento durante su uso.

Notas:

1. Utilice el cargador proporcionado o un cargador estándar (DC5V / 1A) y el cable de carga. Usar otros cargadores puede activar la

protección contra sobrecarga o baja tensión, lo que impide la carga.
2. Si tiene problemas de carga, comuníquese con el soporte al cliente: **support@netvue.com**

1. Il suffit de brancher ou débrancher le câble d'alimentation pour allumer ou éteindre la caméra; aucun bouton n'est nécessaire.
2. La caméra n'a pas de batterie intégrée et doit être connectée à l'alimentation en permanence pendant l'utilisation.

Remarques :

1. Veuillez utiliser le chargeur fourni ou un chargeur standard (DC5V / 1A) et le câble de charge. L'utilisation d'autres chargeurs peut déclencher une surcharge ou une protection contre les basses tensions, empêchant la charge.
2. En cas de problème de charge, veuillez contacter le support client : **support@netvue.com**

1. Stecken Sie einfach das Stromkabel ein oder aus, um die Kamera ein- oder auszuschalten; Tasten sind nicht erforderlich.
2. Die Kamera hat keinen eingebauten Akku und muss während des Gebrauchs ständig an die Stromversorgung angeschlossen sein.

Hinweise:

1. Bitte verwenden Sie das mitgelieferte Ladegerät oder ein Standardladegerät (DC5V / 1A) und das Ladekabel. Die Verwendung anderer Ladegeräte kann eine Überlastung oder Niederspannungsschutz auslösen und das Laden verhindern.
2. Bei Ladeproblemen wenden Sie sich bitte an den Kundendienst: **support@netvue.com**

1. Basta collegare o scollegare il cavo di alimentazione per accendere o spegnere la telecamera; non sono necessari pulsanti.
2. La telecamera non ha una batteria integrata e deve essere collegata alla corrente in ogni momento durante l'uso.

Note:

1. Si prega di utilizzare il caricabatterie fornito o un caricatore standard (DC5V / 1A) e il cavo di ricarica. L'uso di altri caricabatterie potrebbe attivare la protezione da sovraccarico o bassa tensione, impedendo la ricarica.
2. In caso di problemi di ricarica, contattare l'assistenza clienti: support@netvue.com

App Pairing

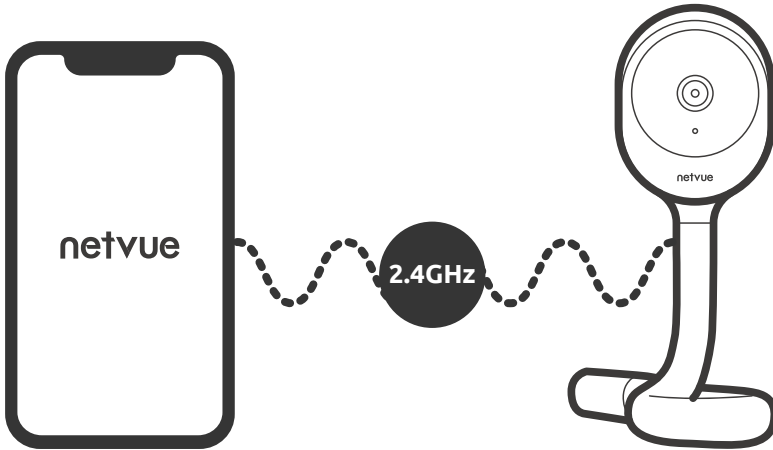

1. Download the Netvue Next app on your phone.
2. Connect the camera to a power source. It should turn on with a short, one-off chime.
3. Briefly press the "Config" button. The yellow light will start flashing, and you will hear periodic chimes.
4. Follow the instructions in the app to complete the pairing.

1. Descargue la aplicación Netvue Next en su teléfono.
2. Conecte la cámara a una fuente de alimentación. Debería encenderse con un sonido corto.
3. Presione brevemente el botón "Config". La luz amarilla comenzará a parpadear y escuchará sonidos periódicos.
4. Siga las instrucciones en la aplicación para completar el emparejamiento.

1. Téléchargez l'application Netvue Next sur votre téléphone.
2. Connectez la caméra à une source d'alimentation. Elle devrait s'allumer avec un court signal sonore.
3. Appuyez brièvement sur le bouton "Config". Le voyant jaune commencera à clignoter et vous entendrez des carillons périodiques.
5. Suivez les instructions dans l'application pour terminer l'appairage.

1. Laden Sie die Netvue Next App auf Ihr Telefon herunter.
2. Schließen Sie die Kamera an eine Stromquelle an. Sie sollte sich mit einem kurzen einmaligen Ton einschalten.
3. Drücken Sie kurz die "Konfig"-Taste. Das gelbe Licht beginnt zu blinken und Sie hören periodische Signaltöne.
4. Folgen Sie den Anweisungen in der App, um die Kopplung abzuschließen.

1. Scarica l'app Netvue Next sul tuo telefono.
2. Collega la telecamera a una fonte di alimentazione. Dovrebbe accendersi con un breve segnale acustico.
3. Premi brevemente il pulsante "Config". La luce gialla inizierà a lampeggiare e sentirai segnali acustici periodici.
4. Segui le istruzioni nell'app per completare l'associazione.

Cloud Services

Continuous Video Recording

Continuous Video Recording (CVR) is a cloud service that allows you to get 24/7 video footage of your baby.

Moment Video Recording

Moment Video Recording (MVR) is a cloud service that allows you to increase the duration of your your motion videos.

You can subscribe to one or both services. For more information, please visit my.netvue.com.

Grabación de video continua

La grabación de video continua (CVR) es un servicio en la nube que te permite obtener grabaciones de video 24/7 de tu bebé.

Grabación de momentos

Moment Video Recording (MVR) es un servicio en la nube que te permite aumentar la duración de tus videos de movimiento.

Puedes suscribirte a uno o ambos servicios. Para obtener más información, visita my.netvue.com.

Enregistrement vidéo continu

L'enregistrement vidéo continu (CVR) est un service cloud qui vous permet d'obtenir des séquences vidéo 24h/24 et 7j/7 de votre bébé.

Enregistrement des moments

Moment Video Recording (MVR) est un service cloud qui vous permet d'augmenter la durée de vos vidéos de mouvement.

Vous pouvez vous abonner à l'un ou aux deux services. Pour plus d'informations, veuillez visiter my.netvue.com.

Kontinuierliche Videoaufzeichnung

Die kontinuierliche Videoaufzeichnung (CVR) ist ein Cloud-Dienst, der Ihnen ermöglicht, 24/7 Videoaufnahmen Ihres Babys zu erhalten.

Momentaufzeichnung

Moment Video Recording (MVR) ist ein Cloud-Service, der es Ihnen ermöglicht, die Dauer Ihrer Bewegungsvideos zu erhöhen.

Sie können einen oder beide Dienste abonnieren. Für weitere Informationen besuchen Sie bitte my.netvue.com.

Registrazione video continua

La registrazione video continua (CVR) è un servizio cloud che ti consente di ottenere riprese video 24/7 del tuo bambino.

Registrazione dei momenti

Moment Video Recording (MVR) è un servizio cloud che ti consente di aumentare la durata dei tuoi video di movimento.

Puoi abbonarti a uno o entrambi i servizi. Per ulteriori informazioni, visita my.netvue.com.

Warning

Note: This equipment has been tested and found to comply with the limits for a Class B digital device, pursuant to part 15 of the FCC Rules. These limits are designed to provide reasonable protection against harmful interference in a residential installation. This equipment generates, uses and can radiate radio frequency energy and, if not installed and used in accordance with the instructions, may cause harmful interference to radio communications. However, there is no guarantee that interference will not occur in a particular installation. If this equipment does cause harmful interference to radio or television reception, which can be determined by turning the equipment off and on, the user is encouraged to try to correct the interference by one or more of the following measures:

- Reorient or relocate the receiving antenna.
- Increase the separation between the equipment and receiver.
- Connect the equipment into an outlet on a circuit different from that to which the receiver is connected.
- Consult the dealer or an experienced radio/TV technician for help.

This device complies with part 15 of the FCC Rules. Operation is subject to the following two conditions: (1) This device may not cause harmful interference, and (2) this device must accept any interference received, including interference that may cause undesired operation.

Any changes or modifications made without explicit approval from the responsible party in compliance may result in the user being unauthorized to operate the device.

This device meets the FCC radiation exposure limits for uncontrolled environments. To ensure safe installation and operation, maintain a minimum distance of 20cm between the radiator and your body.

FCC ID: 2AO8RNI-9000

CE Statement

The information provided on the packaging is allowed to identify geographical areas within the member states where restrictions on use or requirements for authorized use exist, if applicable. The structure of the product allows it to be used in at least one member state without violating applicable requirements for the use of radio spectrum.

NETVUE INC.

1055 East Colorado Boulevard 5th Floor
Pasadena, CA, 91106

IC Statement

This device contains licence-exempt transmitter(s)/receiver(s) that comply with Innovation, Science and Economic Development Canada's licence-exempt RSS(s). Operation is subject to the following two Economic Development Canada's licence-exempt RSS(s). Operation is subject to the following two conditions:

1. This device may not cause interference.
2. This device must accept any interference, including interference that may cause undesired operation of the device.

L'émetteur/récepteur exempt de licence contenu dans le

présent appareil est conforme aux CNR d'Innovation, Sciences et Développement économique Canada applicables aux appareils radio exempts de licence. L'exploitation est autorisée aux deux conditions suivantes:

3. L'appareil ne doit pas produire de brouillage;
4. L'appareil doit accepter tout brouillage radioélectrique subi, même si le brouillage est susceptible d'en compromettre le fonctionnement.

This equipment complies with IC radiation exposure limits set forth for an uncontrolled environment. This transmitter must not be co-located or operating in conjunction with any other antenna or transmitter. This equipment should be installed and operated with a minimum distance of 20cm between the radiator and your body.

Cet équipement respecte les limites d'exposition au rayonnement IC établies pour un environnement non contrôlé. Cet émetteur ne doit pas être localisé ou fonctionner en conjonction avec une autre antenne ou un autre émetteur. Cet équipement doit être installé et utilisé à une distance minimale de 20cm entre le radiateur et votre corps.

Manufacturer: NETVUE INC.

1055 East Colorado Boulevard 5th Floor, Pasadena, CA, 91106

+1 (866) 749-0567 support@netvue.com

Made in China

Designed in USA

Model: NI-9001



Icamera International Trading Co., Ltd

Unit G25 Waterfront Studios

1 Dock Road, London, United Kingdom

Support@netvue.com



eVatmaster Consulting GmbH

Raiffeisen Street 2B11, 63110, Rodgau, Hessen, Germany

Support@netvue.com



NETVUE INC.

1055 East Colorado Boulevard, 5th Floor, Pasadena, CA, 91106

+1(866)749-0567

Support@netvue.com



Contains batteries, keep away from fire.

Enthält Batterien, von Feuer fernhalten.

Contient des piles, tenir à l'écart du feu.

Contiene batterie, tenere lontano dal fuoco.

Contiene baterías, mantener alejado del fuego.

netvue

Contact us at:



support@netvue.com



In-App Chat



1(866)749-0567
Mon-Fri, 9am-5pm, PST

www.netvue.com

© Netvue Inc.



产品名称:	Netvue Peekababy(无屏幕)	印刷颜色:	单色黑	装帧:	骑马钉	日期:	2025-04-17
说明书尺寸:	150mm*210mm	材质:	哑粉纸105g		设计师:	刘星然	

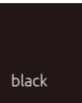

该页不要印刷出来

设计文件须知

- 1.此文件为Birdfy设计部出品,请勿修改相关设计文件,如有修改请联系设计师
- 2.所有的文件需经相关部门负责人审核校对
- 2.设计师在交稿之前应对文件仔细校对以确保图纸准确性
- 3.生产过程中涉及的纸张、色彩等需与设计沟通