



TXJWB12



**12" TAILGATE MOUNTED ENCLOSURE
FOR JEEP® WRANGLER JL / JLU / JK / JKU**

INSTALLATION GUIDE

NOTE! Read this installation guide thoroughly before disassembling or modifying the vehicle. Installation of this product requires technical skill, experience and specialized tools. If in doubt, it's recommended to have it professionally installed by an authorized **Stinger** or **AudioControl** Dealer.

INSTALLATION NOTES

The TXJWB12 is designed to mount to both Wrangler JK and Wrangler JL tailgates. There are two different hardware packs included and this guide covers both types of mounting.

- For JK/JKU models equipped with a factory subwoofer on the right side of the cargo area, only compatible if removed.
- For JL models equipped with a Cargo TrailRail, the TrailRail will no longer be accessible with the speaker enclosure installed.
- For models equipped with a factory subwoofer, unplugging the factory subwoofer is recommended.
- Some installation steps are more easily completed with a second person.
- Speaker wire is required before the enclosure is mounted.
- Recommended amplifier rating: 200-600 watts @ 2ohms.

GETTING STARTED

1.1

Remove the four Philips screws from the speaker and remove the speaker. Set speaker and screws in a safe place.

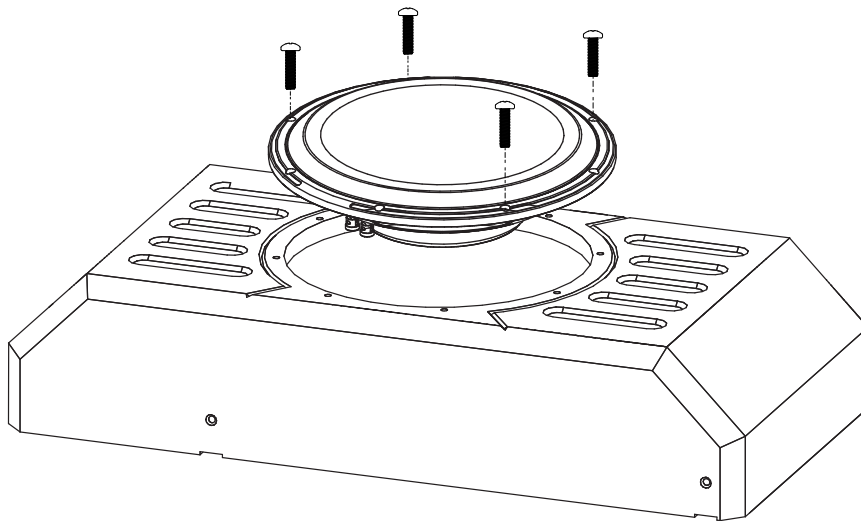

Remove the JK Paper Template from inside the enclosure. Select the correct hardware pack for your installation and confirm hardware quantities and tools required using the guides on the following pages.

JL HARDWARE

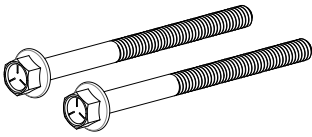
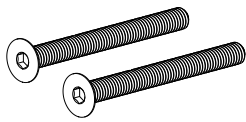
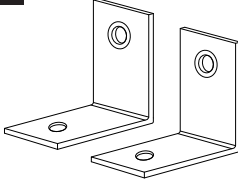
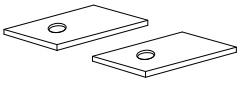
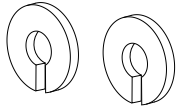
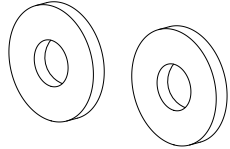
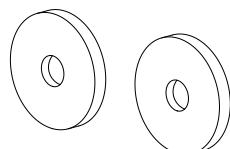
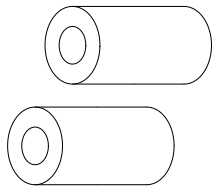
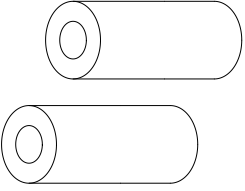
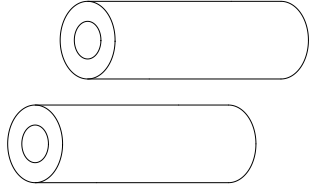
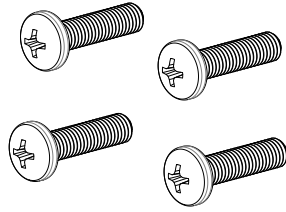
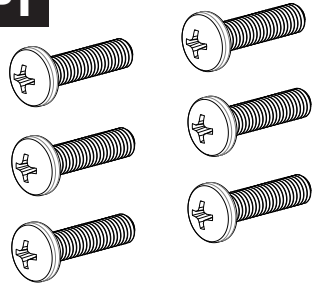
| | | | |
|--|--|---|---|
| <p>B1</p>  | <p>B2</p>  | <p>L1</p>  | <p>L2</p>  |
| <p>M6 FLANGED HEX HEAD BOLT (2) 75mm / 2.95in Length</p> | <p>M6 FLAT HEAD BOLT (2) 60mm / 2.36in Length</p> | <p>BOTTOM L BRACKETS (2)</p> | <p>FOAM BRACKET PAD (2)</p> |
| <p>W1</p>  | <p>W2</p>  | <p>W3</p>  | <p>S1</p>  |
| <p>M6 SPLIT LOCK WASHER (2)</p> | <p>M6 METAL WASHER (2) 18mm / .71in Diameter</p> | <p>M6 RUBBER WASHERS (2) 18mm / .71in Diameter</p> | <p>SPACER - 13mm Diameter (2) 27mm / 1.06in Length</p> |
| <p>S2</p>  | <p>S3</p>  | <p>P1</p>  | <p>P1</p>  |
| <p>SPACER - 13mm Diameter (2) 30mm / 1.18in Length</p> | <p>SPACER - 13mm Diameter (2) 45mm / 1.77in Length</p> | <p>M5 PHILIPS HEAD SCREW (4) 30mm / .78in Length (Removed from speaker)</p> | <p>M5 PHILIPS HEAD SCREW (6) 30mm / .78in Length (Included in JK Hardware)</p> |

NOTE: Hardware images not to scale. There will be hardware left over depending on the installation

JL RECOMMENDED TOOLS

#2 Philips Screwdriver
4mm Allen Wrench
5mm Allen Wrench
Nylon Panel Tool
10mm Socket
Ratchet
Socket Extension
Torx T40

Pilot Hole Drill Bit
13mm Drill Bit (Included)
Drill
Wire Strippers

JK HARDWARE

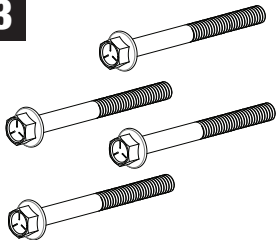
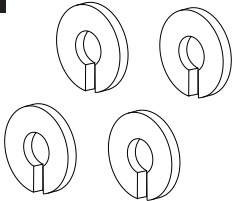
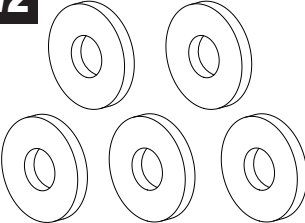
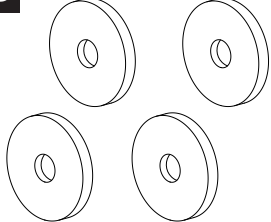
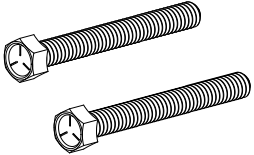
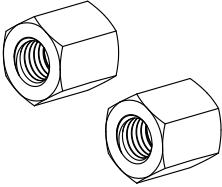
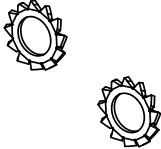
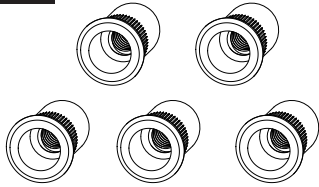
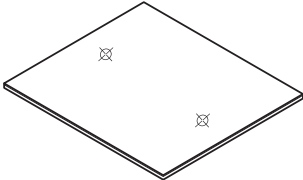
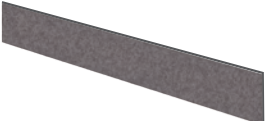
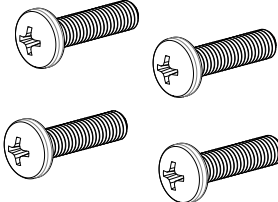
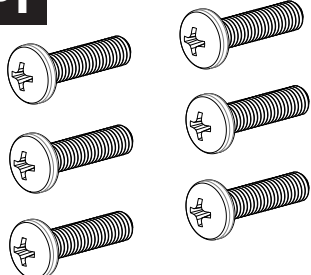
| | | | |
|---|---|--|--|
| B3  | W1  | W2  | W3  |
| M6 FLANGED HEX HEAD BOLT (5) 40mm / 1.57in Length | M6 SPLIT LOCK WASHER (4) | M6 METAL WASHER (4) 18mm / .71in Diameter | M6 RUBBER WASHERS (4) 18mm / .71in Diameter |
| B4  | N1  | W4  | R1  |
| M6 HEX HEAD BOLT (2) 40mm / 1.57in Length | M8 HEX HEAD NUT (2) | M6 TOOTH LOCK WASHER (2) | M6 RIVET NUT INSERTS (5) |
| S2  | F1  | P1  | P1  |
| TEMPLATE (1) JK Hole Positions | FOAM (1) JK Wire Covering | M5 PHILIPS HEAD SCREW (4) 30mm / .78in Length (Removed from speaker) | M5 PHILIPS HEAD SCREW (6) 30mm / .78in Length (Included in JK Hardware) |

NOTE: Hardware images not to scale. Additional hardware has been provided in the event it is required.

JK RECOMMENDED TOOLS

#2 Philips Screwdriver
5mm Allen Wrench
13mm Wrench
10mm Socket
Ratchet
Socket Extension

9mm Drill Bit (Included)
Drill
Center Punch
Hammer
Tape
Wire Strippers

Rivet Nut Setter (Optional)

| Contents | Section | Page |
|-----------------------------------|---------|------|
| JL Installation without TrailRail | 2.1 | 5 |
| JL Installation with TrailRail | 3.1 | 9 |
| JK Installation | 4.1 | 14 |
| Specifications | 5.1 | 19 |

JL INSTALLATION (WITHOUT TRAILRAIL)

2.1

With the speaker removed and the enclosure face down, remove the two 4mm allen hex screws from the bottom panel. These screws will be reused to install the enclosure.

Remove the two silver 5mm allen hex screws from the top of the back panel and discard.

NOTE: The remaining four screws need to remain installed in the back panel.

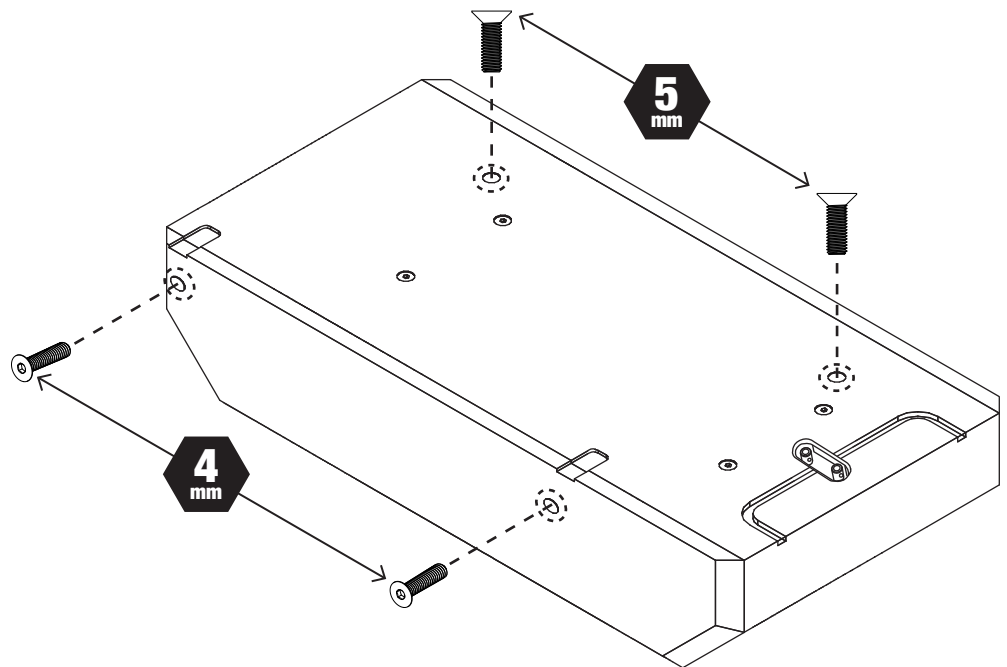

JL INSTALLATION (WITHOUT TRAILRAIL)

2.2

Using a nylon panel tool or similar, remove the tailgate door panel.

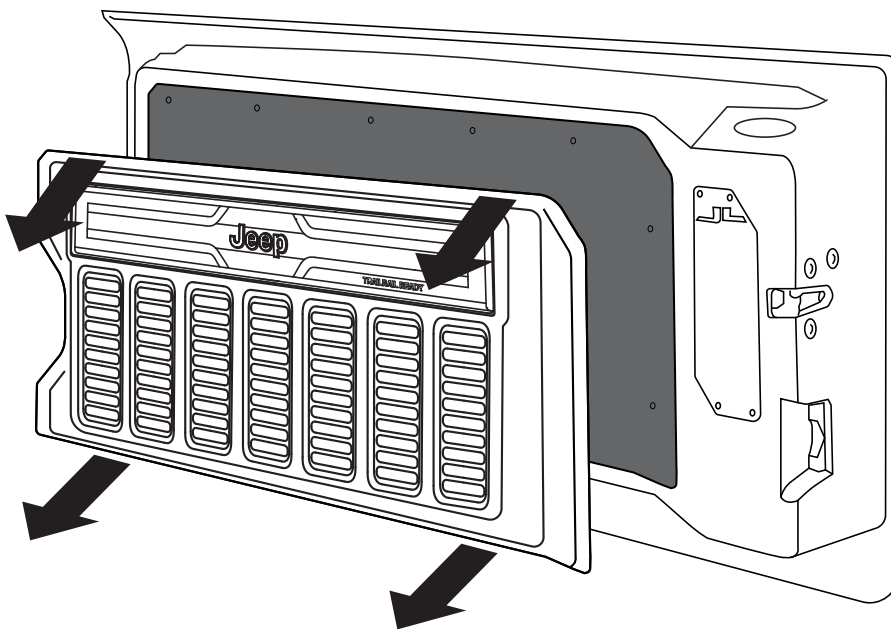

2.3

With the door panel face down on a soft surface, drill four 13mm holes at the locations indicated.

NOTE: The marks shown are molded into the plastic. Drill center of markings.

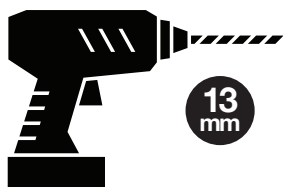
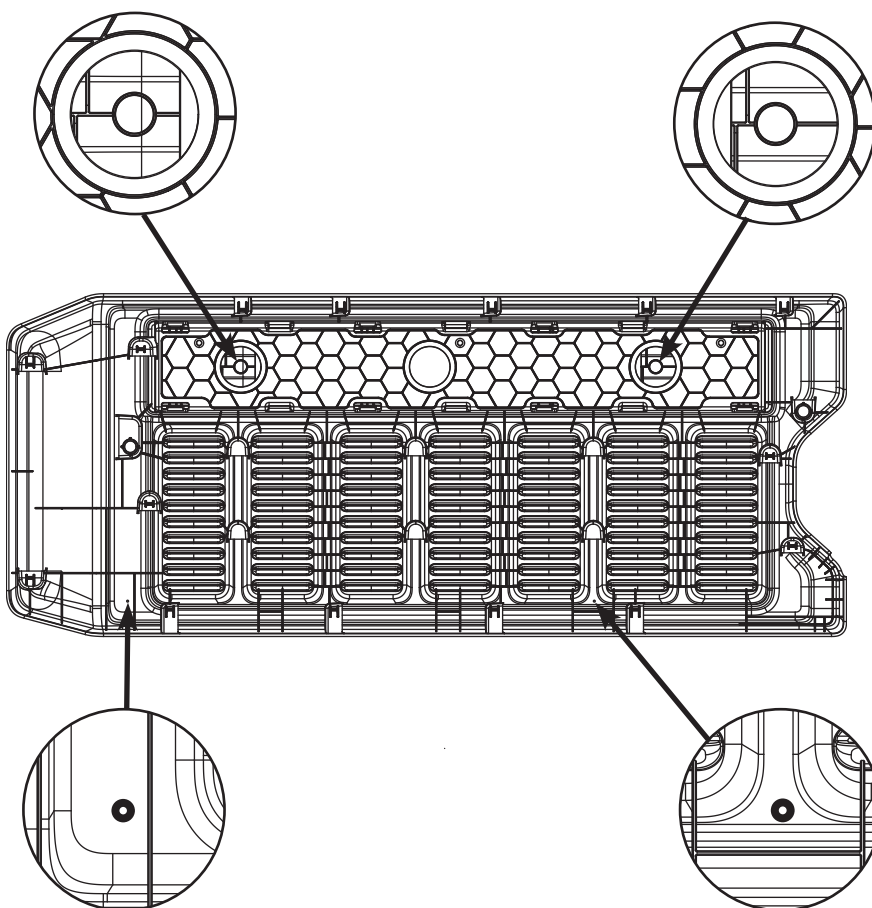

JL INSTALLATION (WITHOUT TRAILRAIL)

2.4

Run a suitable length of speaker wire into the tailgate following the factory wire harness.

Route the speaker wire through a vent opening on the left side of the door panel.

Reinstall the door panel by aligning the retaining clips and then pushing to fully seat all the clips

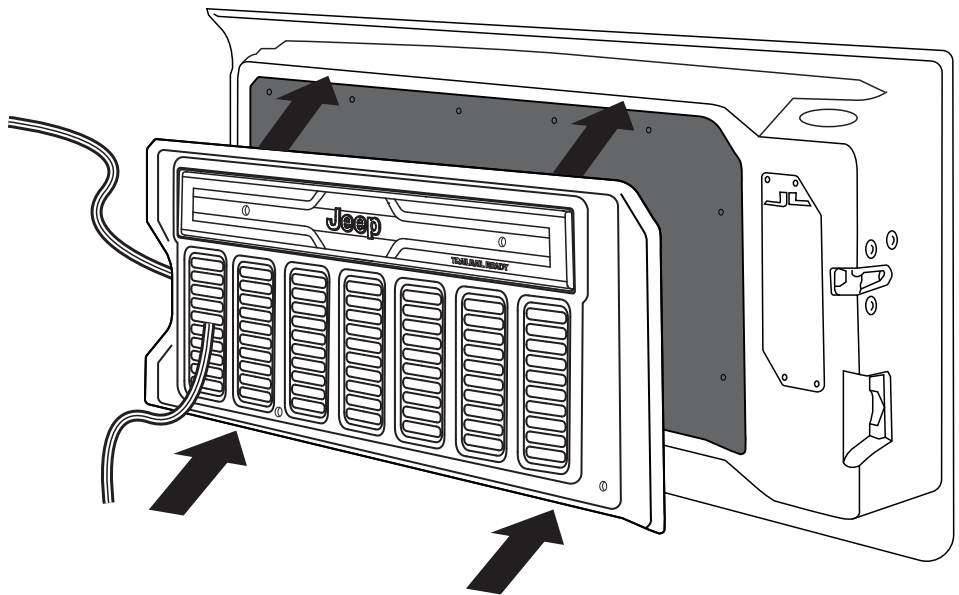

2.5

Install two **S2** 30mm Spacers in the top hole locations.

Install two **S3** 45mm Spacers in the bottom hole locations. Using a **B2** 4mm allen bolt, attach the L Brackets with the tapered hole facing the mounting bolt.

Apply the two **L2** foam pads to the L Brackets.

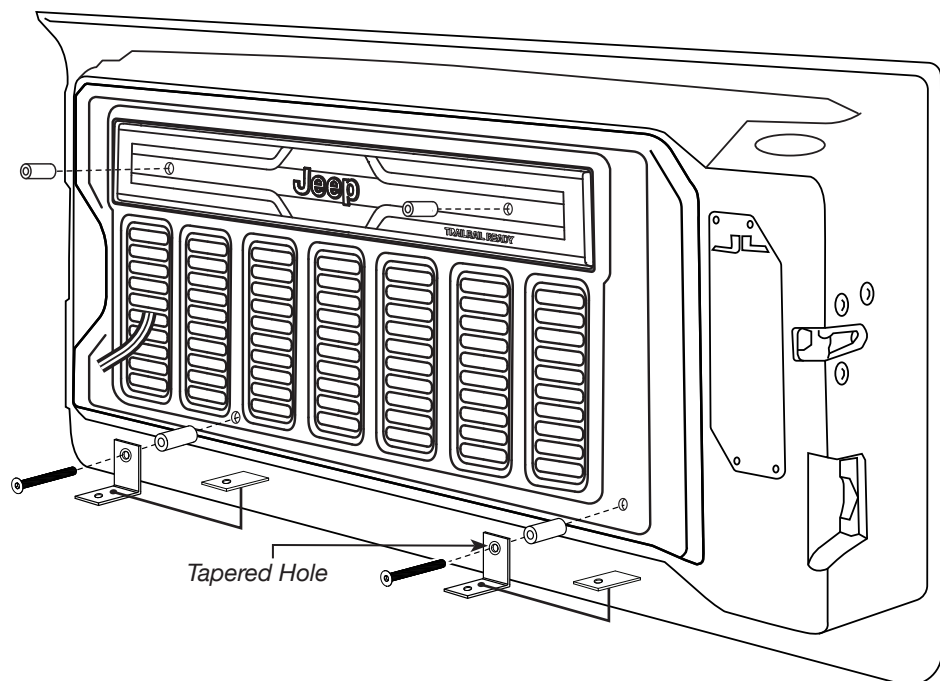

JL INSTALLATION (WITHOUT TRAILRAIL)

2.6

Connect the speaker wire to the terminals. Positive (+) is Red and Negative (-) is Black.

Route the speaker wire in the lower channel.

NOTE: This step is most easily accomplished with help, or another means of supporting the enclosure at the correct elevation.

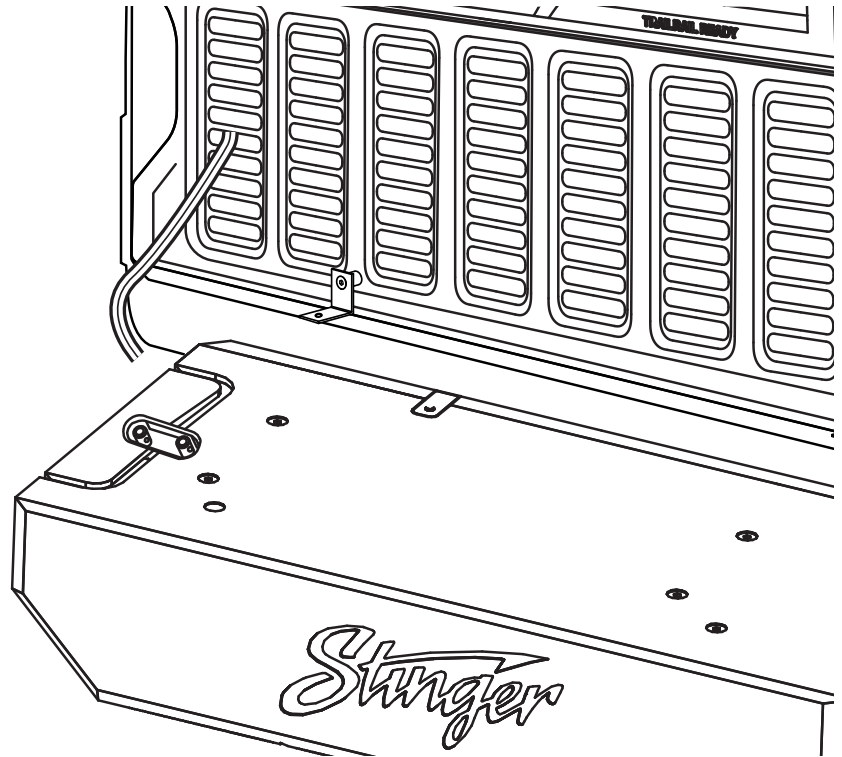

2.7

With the speaker enclosure aligned and resting on the L Brackets, loosely install the indicated hardware in the top mounting locations inside the enclosure.

Install the two 4mm allen hex screws removed in Step 2.1 into the bottom locations.

Tighten all hardware.

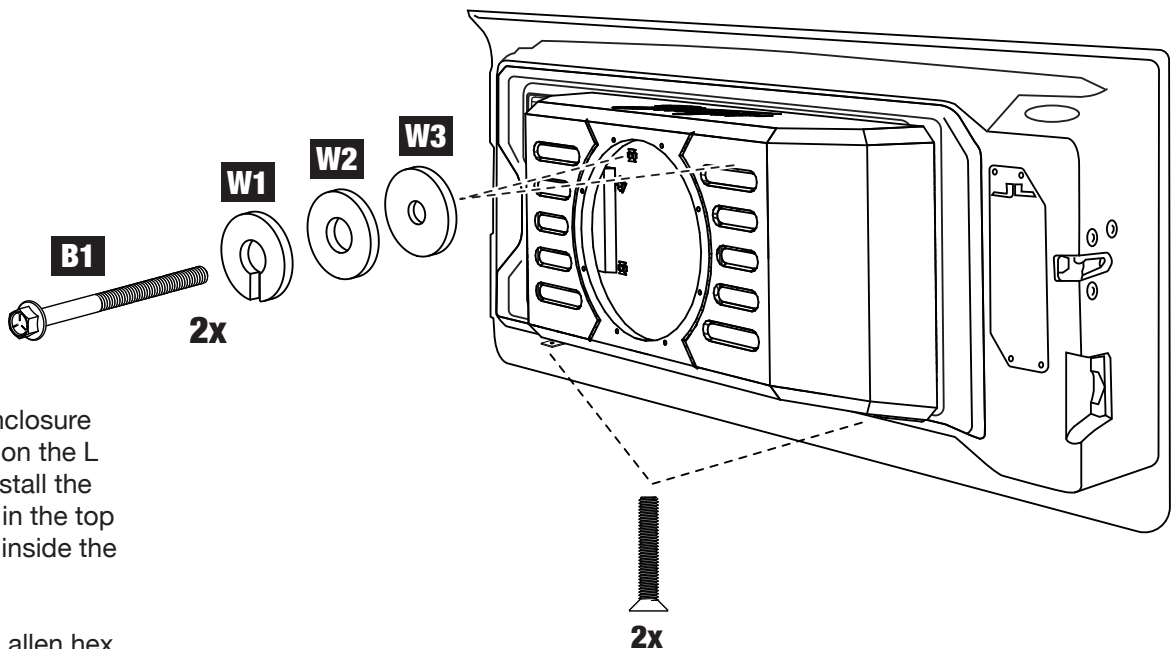

JL INSTALLATION (WITHOUT TRAILRAIL)

2.8

A. Place the sheet of poly-fill inside the enclosure along the back and side areas.

B. Connect the speaker leads inside the enclosure to either of the speaker terminals on the speaker. Positive (+) is Red and Negative (-) is Black.

NOTE: Ensure the pre-installed speaker terminal jumper wires stay connected when connecting the wires to the speaker terminal.

C. Align the speaker and install eight **P1** screws securing the speaker.

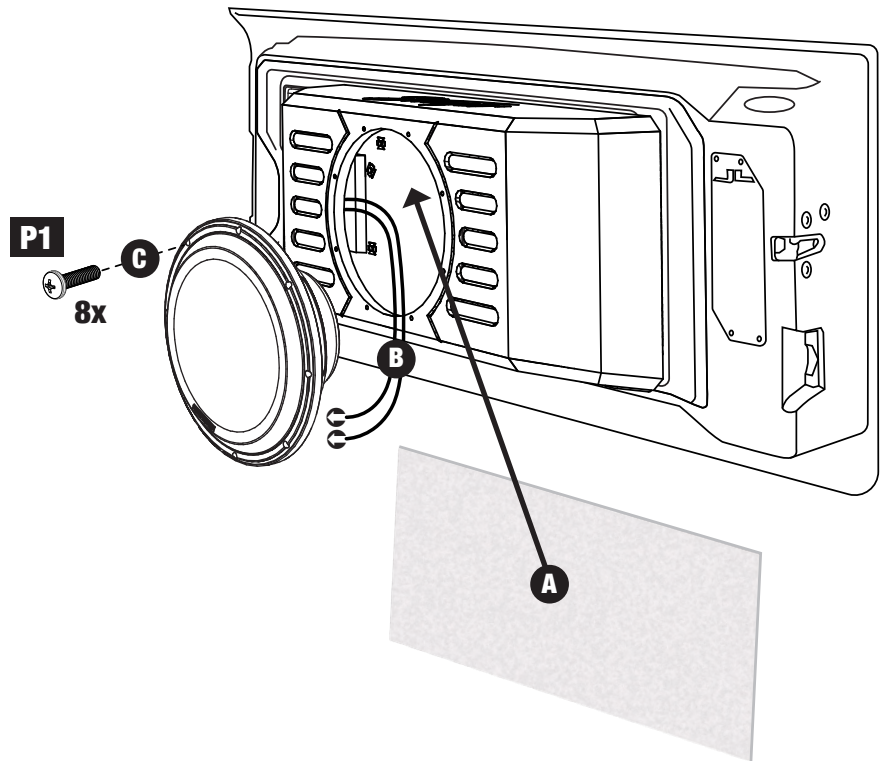

JL INSTALLATION (WITH TRAILRAIL)

3.1

With the speaker removed and the enclosure face down, remove the two 4mm allen hex screws from the bottom panel. These screws will be reused to install the enclosure.

Remove the two silver 5mm allen hex screws from the top of the back panel and discard.

NOTE: The remaining four screws need to remain installed in the back panel.

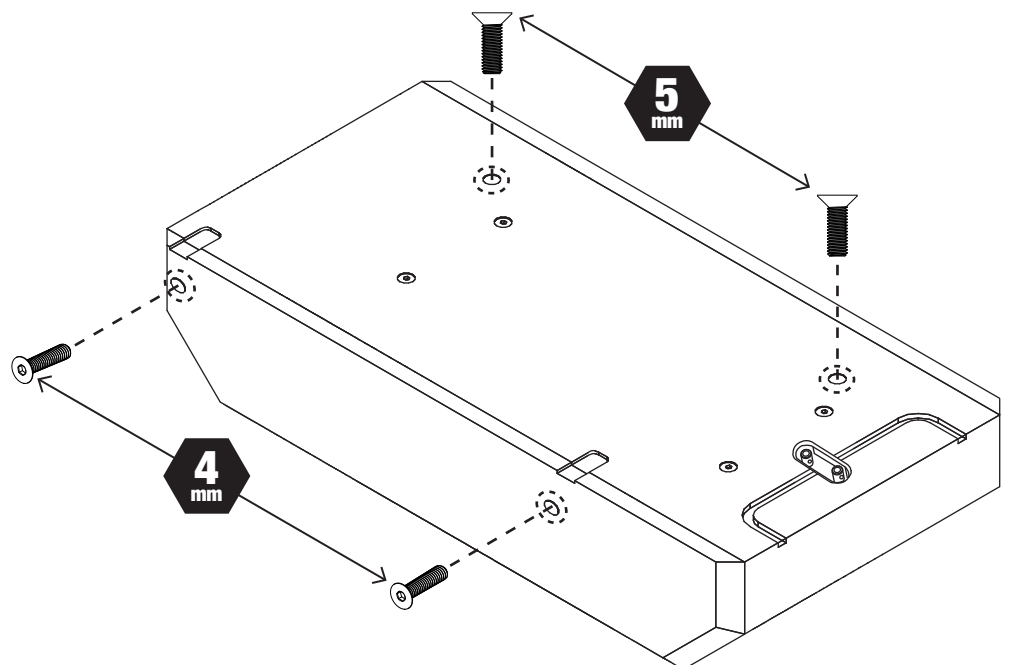

JL INSTALLATION (WITH TRAILRAIL)

3.2

Remove the three Torx T40 screws from the Trail Rail and remove the Trail Rail.

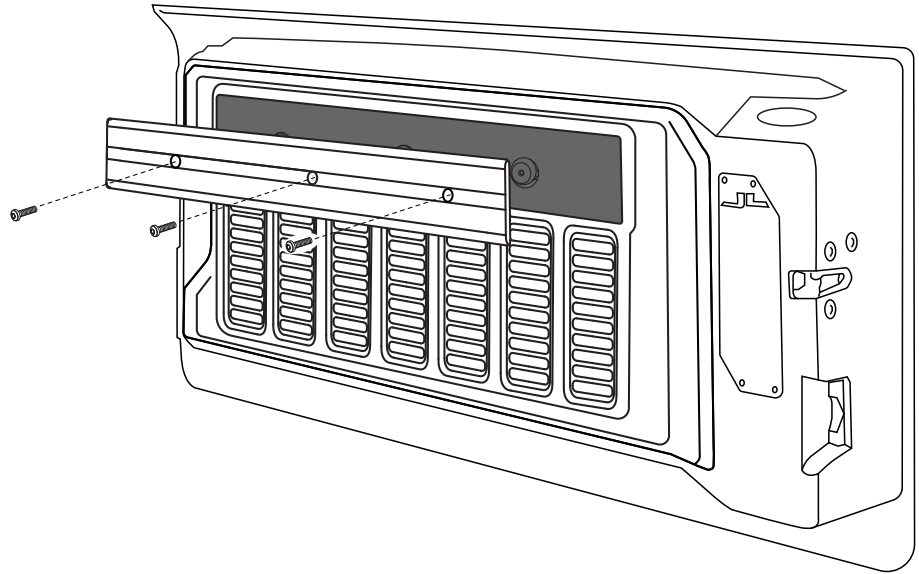

3.3

Using a nylon panel tool or similiar, remove the tailgate door panel.

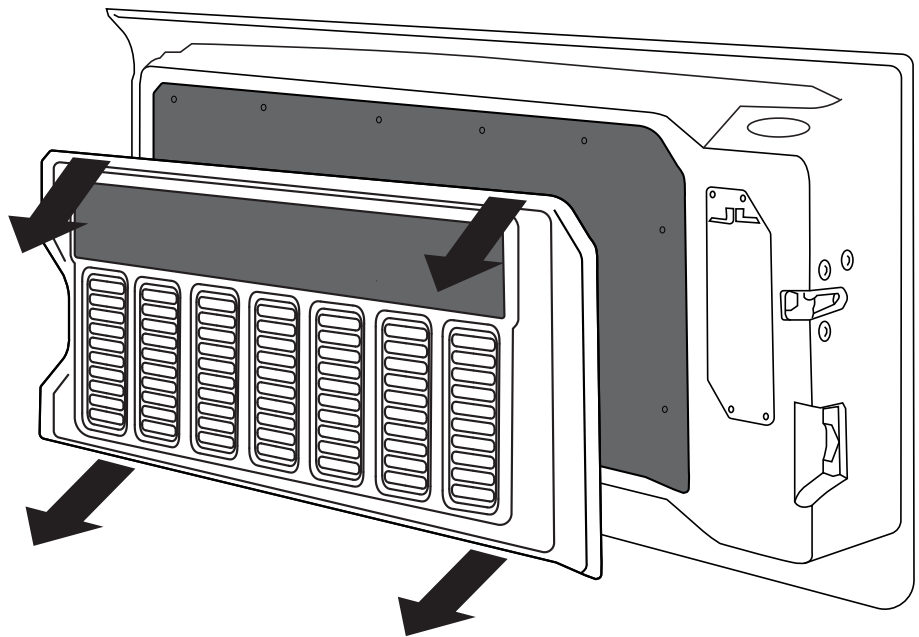

JL INSTALLATION (WITH TRAILRAIL)

3.4

With the door panel face down on a soft surface, drill two 13mm holes at the locations indicated.

NOTE: The marks shown are molded into the plastic. Drill center of markings.

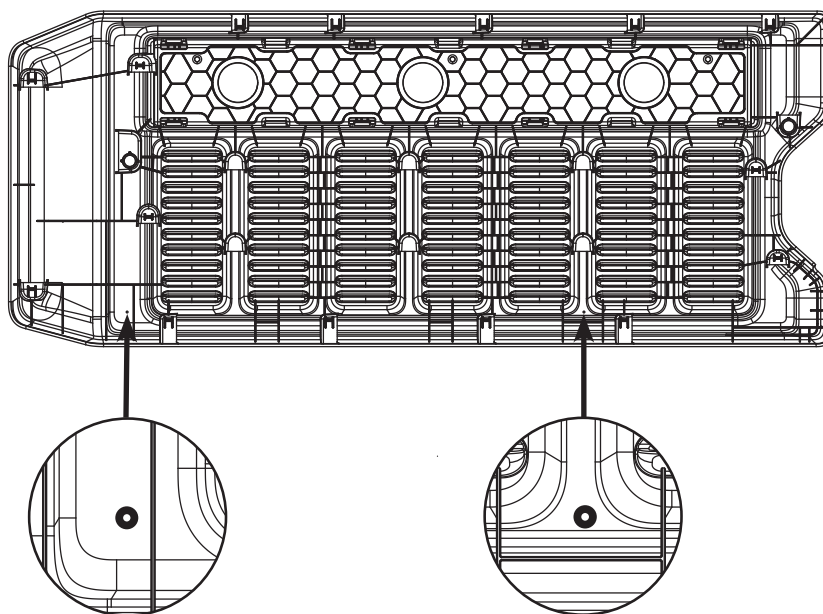
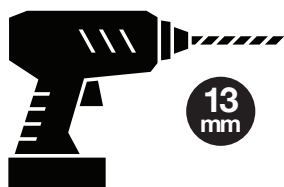

3.5

Run a suitable length of speaker wire into the tailgate following the factory wire harness.

Route the speaker wire through a vent opening on the left side of the door panel.

Reinstall the door panel by aligning the retaining clips and then pushing to fully seat all the clips.

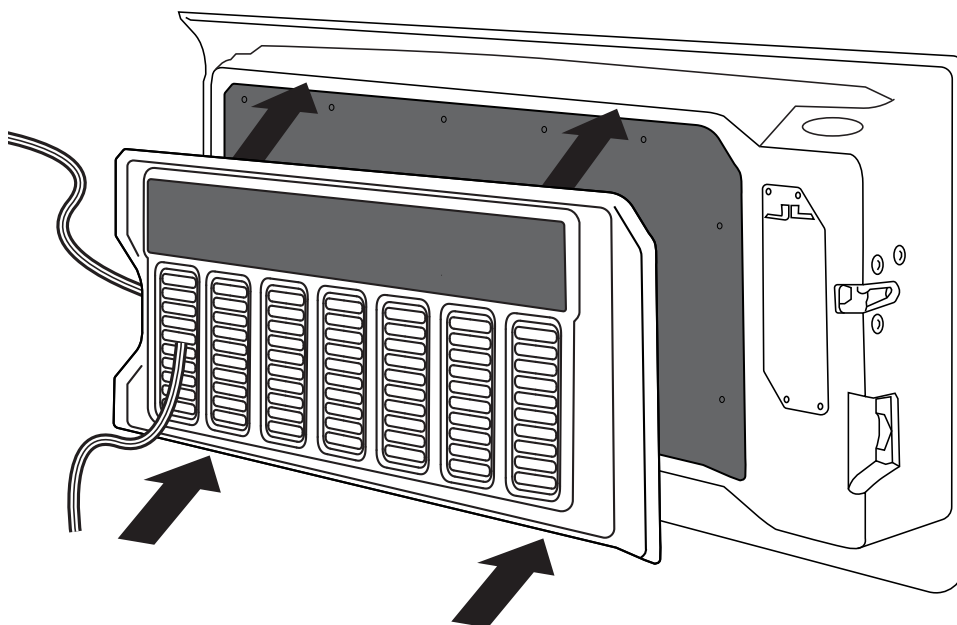

JL INSTALLATION (WITH TRAILRAIL)

3.6

Install the Trail Rail using one of the removed Torx T40 screws in the center mounting hole.

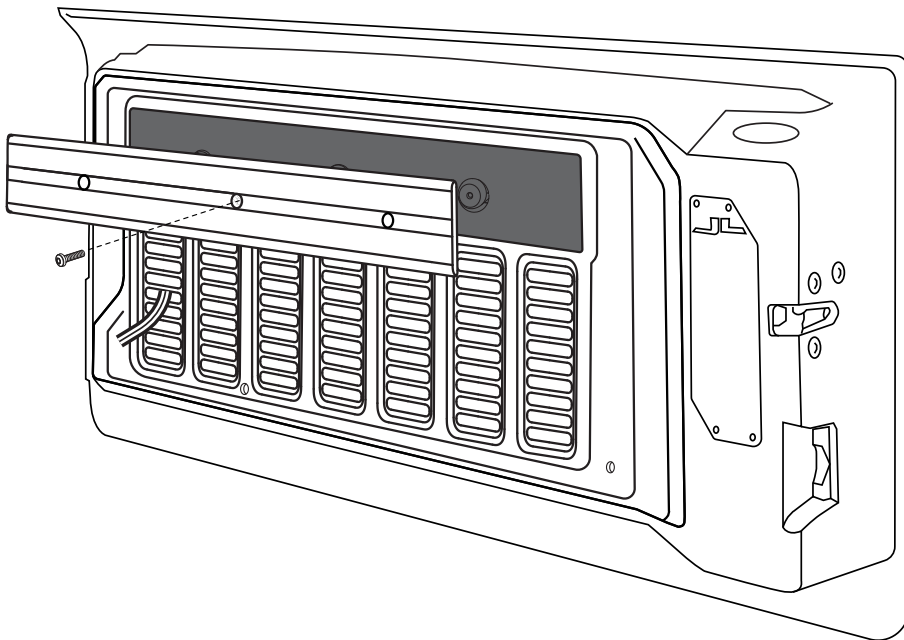

3.7

Install two **S1** 27mm Spacers in the top hole locations.

Install two **S3** 45mm Spacers in the bottom hole locations. Using a **B2** 4mm allen bolt, attach the L Brackets with the tapered hole facing the mounting bolt.

Apply the two **L2** foam pads to the L Brackets.

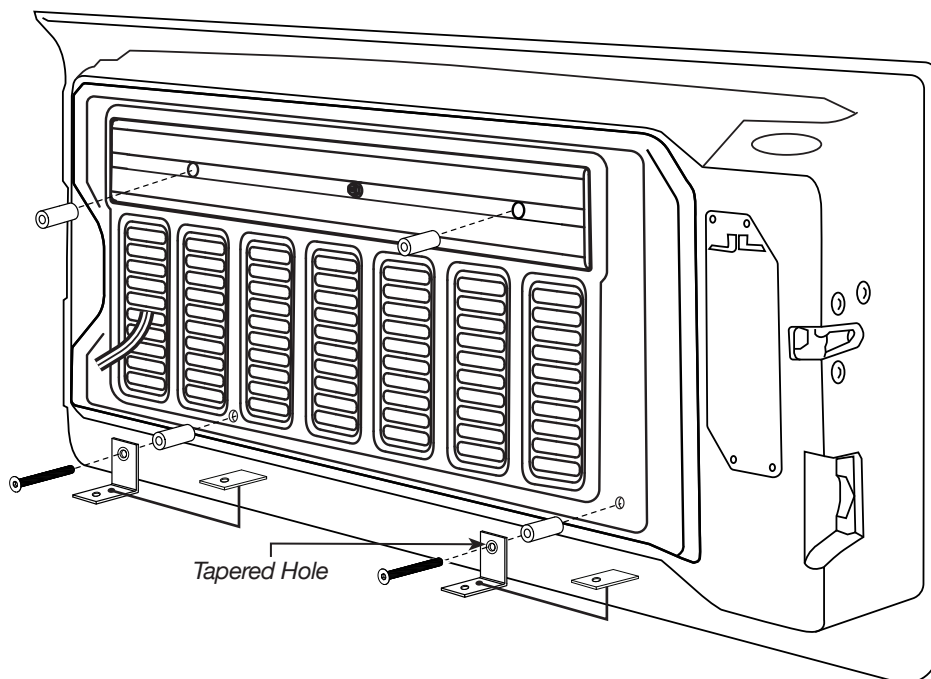

JL INSTALLATION (WITH TRAILRAIL)

3.8

Connect the speaker wire to the terminals. Positive (+) is Red and Negative (-) is Black.

Route the speaker wire in the lower channel.

NOTE: This step is most easily accomplished with help, or another means of supporting the enclosure at the correct elevation.

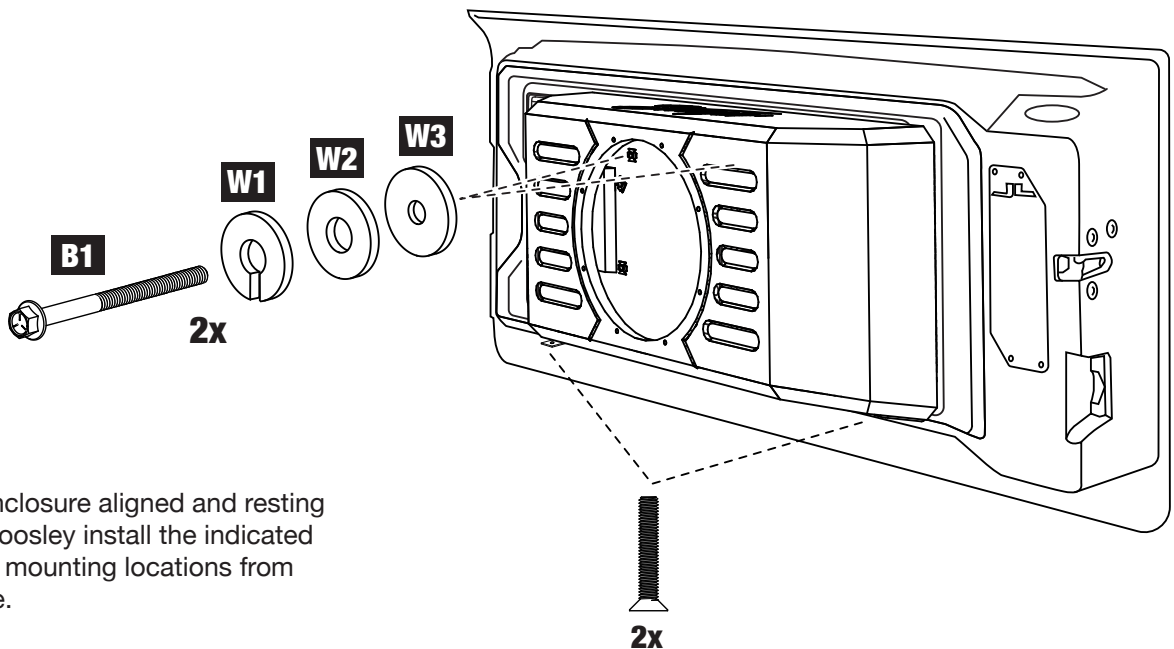
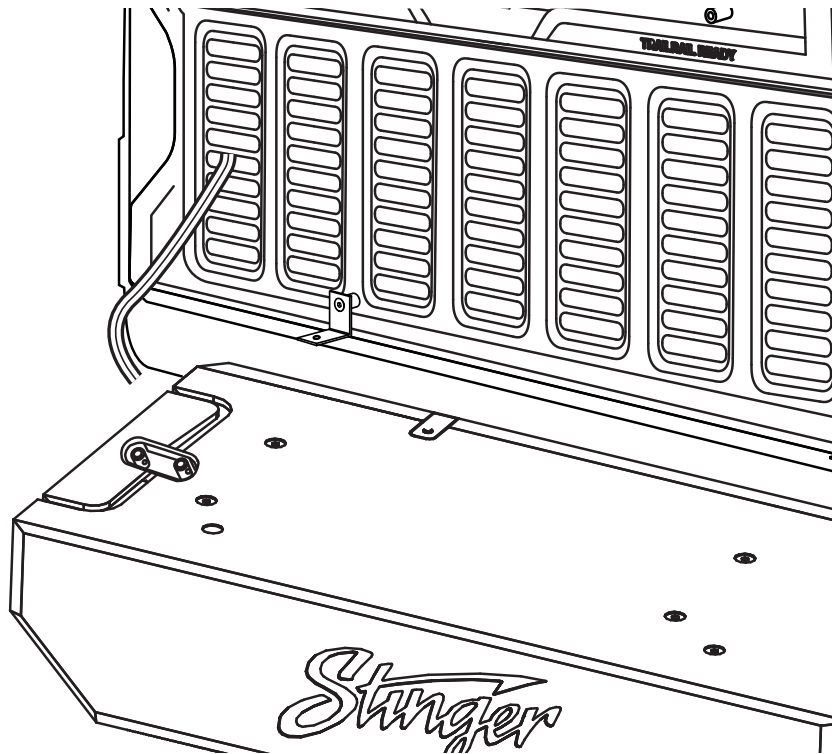

3.9

With the speaker enclosure aligned and resting on the L Brackets, loosely install the indicated hardware in the top mounting locations from inside the enclosure.

Install the two 4mm allen hex screws removed in Step 3.1 into the bottom locations.

Tighten all hardware.

JL INSTALLATION (WITH TRAILRAIL)

3.10

A. Place the sheet of poly-fill inside the enclosure along the back and side areas.

B. Connect the speaker leads inside the enclosure to either of the speaker terminals on the speaker. Positive (+) is Red and Negative (-) is Black.

NOTE: Ensure the pre-installed speaker terminal jumper wires stay connected when connecting the wires to the speaker terminal.

C. Align the speaker and install eight **P1** screws securing the speaker.

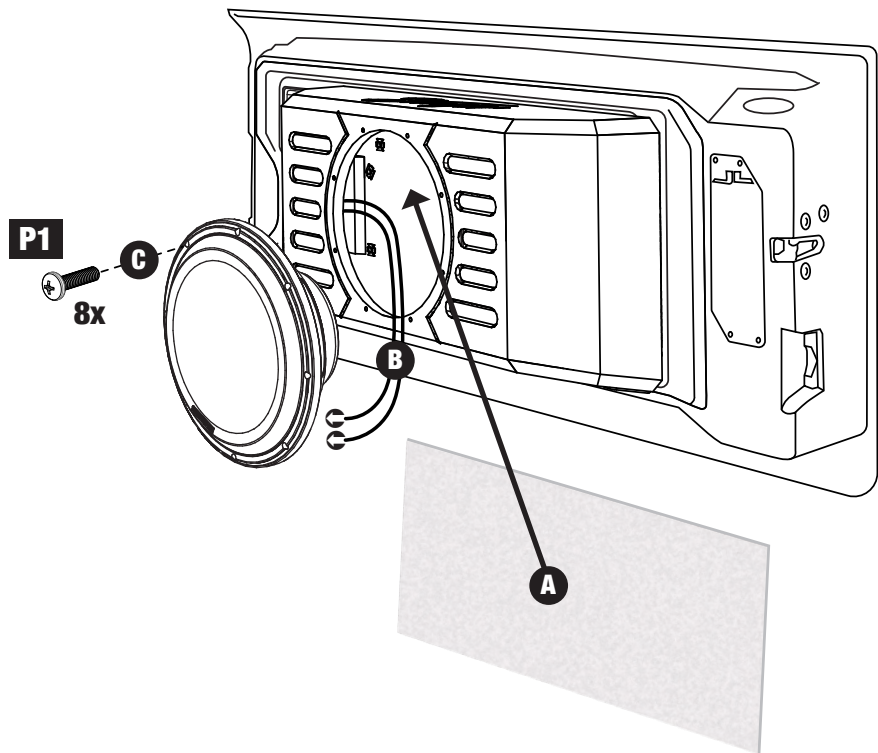

JK INSTALLATION

4.1

With the speaker removed and the enclosure face down, remove the four black 5mm allen hex screws from the back panel.

NOTE: The remaining four screws need to remain installed in the back and bottom panels.

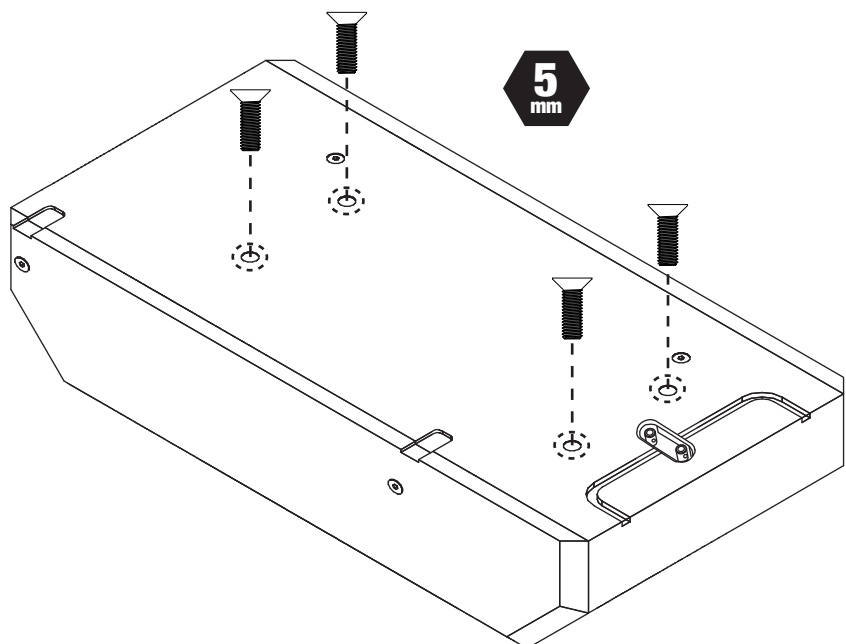

JK INSTALLATION

4.2

Starting along the bottom, use a nylon panel tool or similar to remove the trim panel from the tailgate.

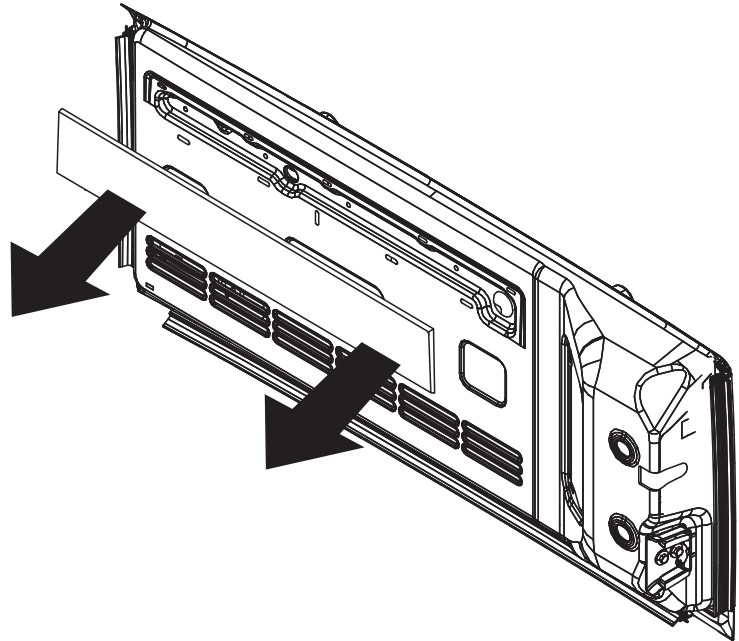

4.3

Align and tape the template to the tailgate panel using the four reference points indicated.

Center punch the four hole locations and remove the template.

CAUTION: To prevent the drill bit from hitting the outer side of the tailgate, wrap a significant amount of tape around the drill bit leaving only 1/2" of the bit exposed.

Drill 9mm holes at the four marked locations.

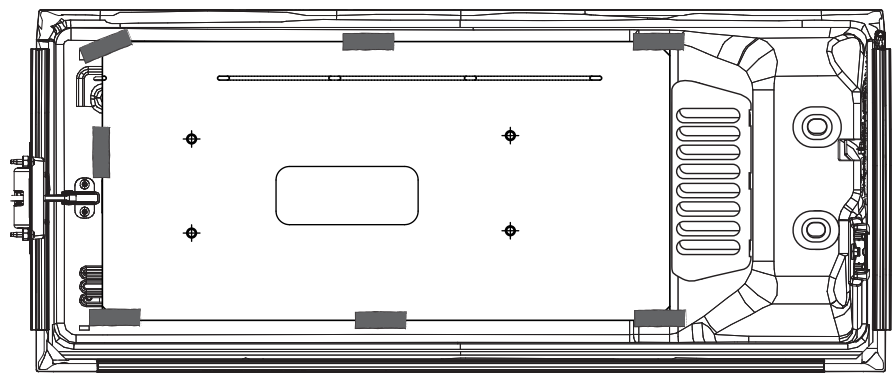
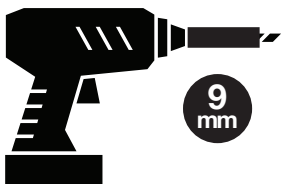
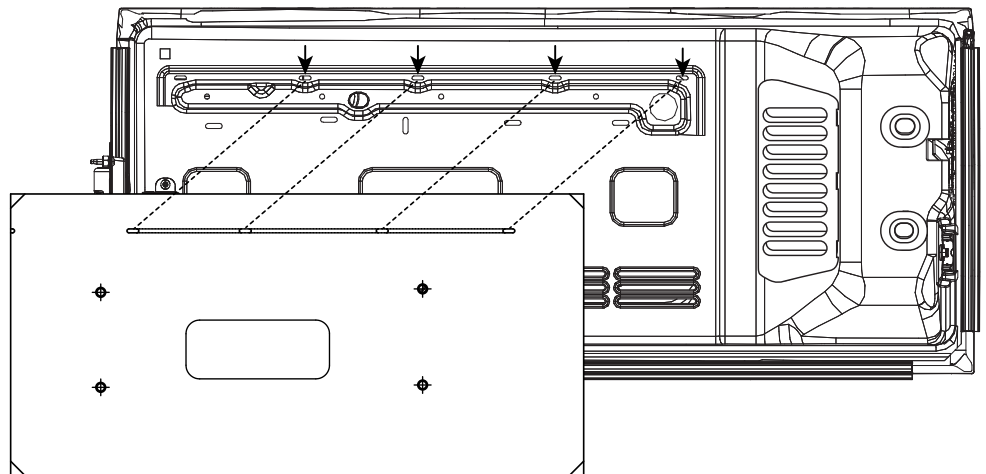

JK INSTALLATION

4.4

If a rivet nut setter is not available, follow the directions below for each of the four holes:

- A. Insert a **R1** rivet nut into the hole.
 - B. Slide an **W2** metal washer, a **N1** spacer nut and a **W4** tooth lock washer onto one of the **B4** bolts.
 - C. Hand thread the bolt into the rivet nut until it is hand tight.
 - D. Using a 14mm wrench to hold the spacer nut, start tightening the bolt with a 10mm socket.
- Ensure the the rivet nut remains fully inserted and flat against the panel surface while tightening.
- The wrench and spacer nut should be held in place; do not rotate.
- The rivet nut takes approximately 12-13 quarter turns to properly seat. The bolt will get harder to turn when the rivet nut is seated.
- E. Once installed, loosen and remove the 10mm bolt while continuing to hold the spacer nut in place with the wrench.

NOTE: After installing the first rivet nut, ensure the side of the spacer nut that was positioned against the tooth lock washer is the same for the remaining installations.

There are two bolts, spacer nuts and washers provided in the event they are needed.

TIP: Having a second person hold the wrench in place and using two hands to tighten with the ratchet will allow you to apply more forward pressure while tightening, keeping the insert flush against the panel.

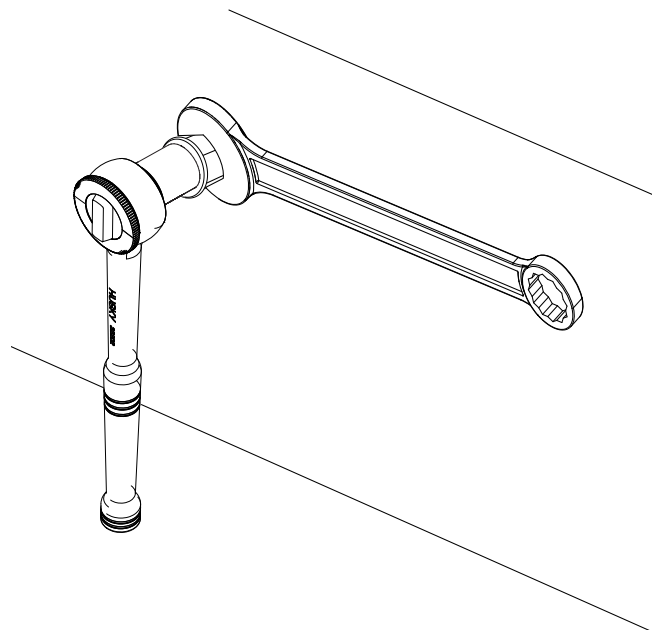
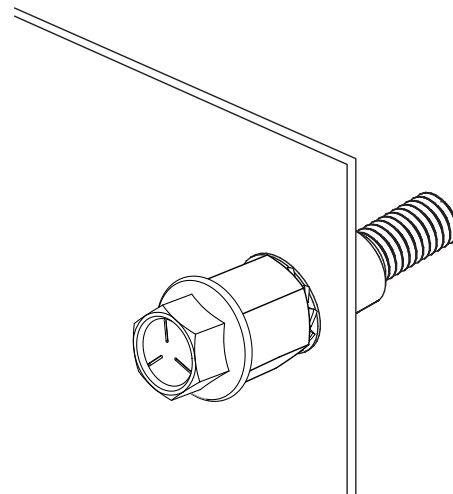
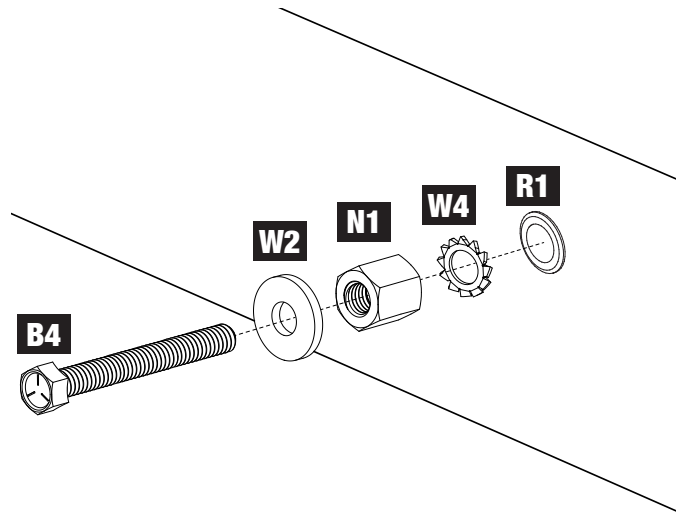

JK INSTALLATION

4.5

A. Apply the Foam Strip over the factory wire harness running across the tailgate using the double sided tape.

B. Run a suitable length of speaker wire into the tailgate following the factory wire harness.

Connect the speaker wire to the terminals. Positive (+) is Red and Negative (-) is Black. Route the speaker wire in the top channel.

NOTE: Connecting the speaker wire and mounting the enclosure is most easily accomplished with help, or another means of supporting the enclosure at the correct elevation. Alternatively, the speaker enclosure can be positioned inside the cargo area and the tailgate closed.

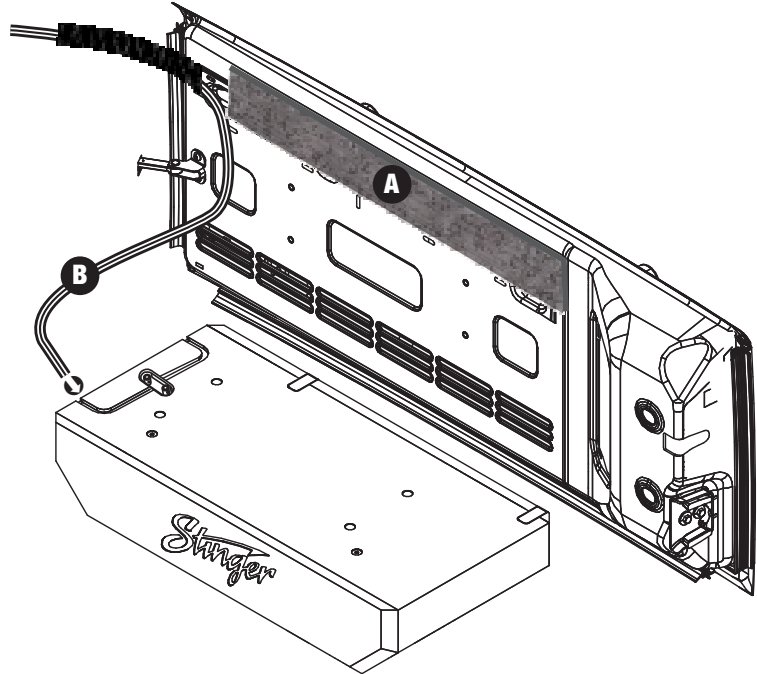

4.6

Align the speaker enclosure to the mounting points on the tailgate. Loosely install the indicated hardware from inside the enclosure.

Once all the bolts are threaded, tighten all hardware.

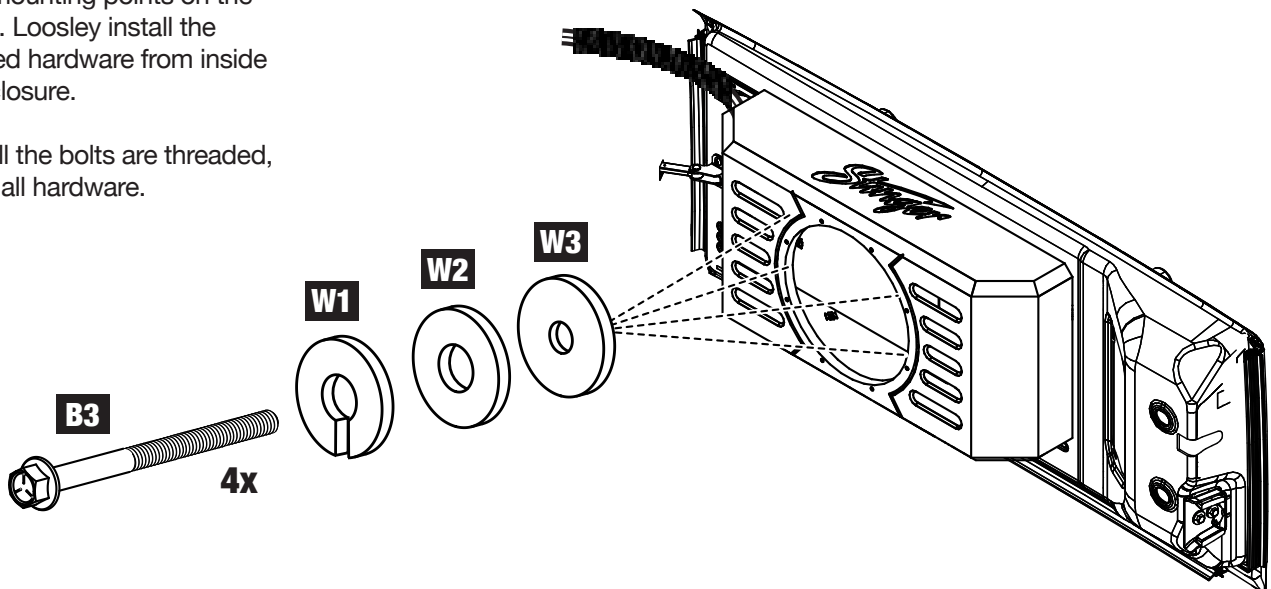

JK INSTALLATION

4.7

A. Place the sheet of poly-fill inside the enclosure along the back and side areas.

B. Connect the speaker leads inside the enclosure to either of the speaker terminals on the speaker. Positive (+) is Red and Negative (-) is Black.

NOTE: Ensure the pre-installed speaker terminal jumper wires stay connected when connecting the wires to the speaker terminal.

C. Align the speaker and install eight **P1** screws securing the speaker.

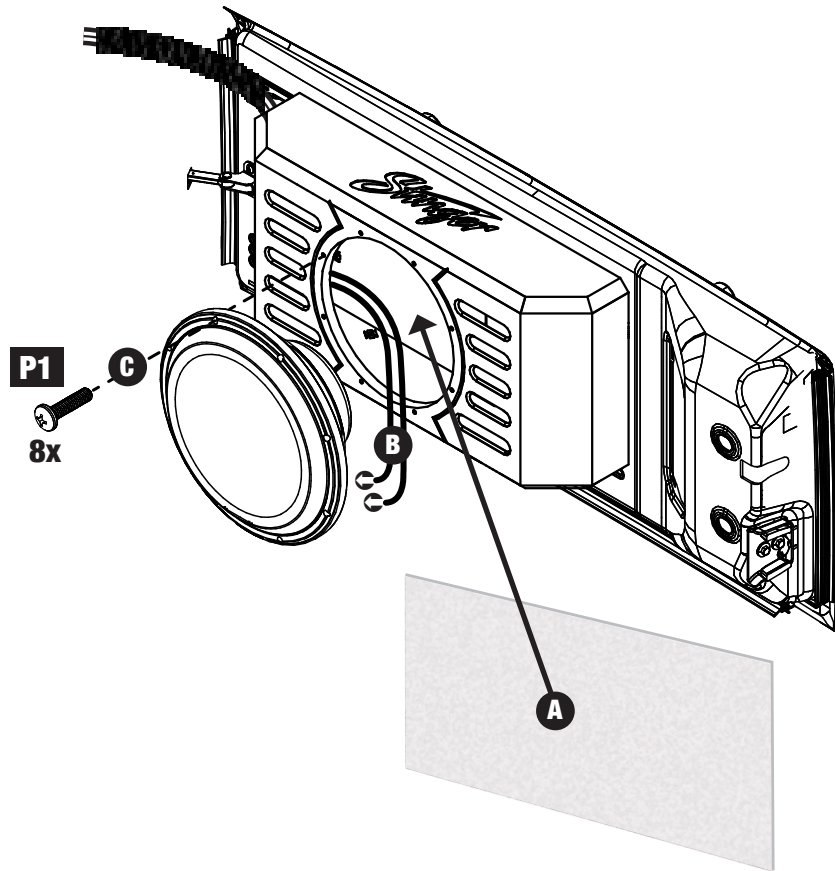

SPECIFICATIONS

| | |
|---------------------------------|----------------------------------|
| Model Number | TXJWB12 |
| Speaker Model | SPC-12S2 |
| Subwoofer Size | 12" |
| Voice Coil | Single 2 ohm |
| DC Resistance (Re) | 2 ohm |
| Sensitivity 1W/M (SPL) | 87 dB |
| Frequency Response | 20Hz - 250Hz |
| RMS Power | Min 200w - Ideal 400w - Max 600w |
| Speaker Displacement | 0.06 cu ft / 1.82 Ltr |
| Speaker Weight | 12.5 lbs |
| Enclosure Specifications | |
| Internal Volume | 0.87 cu ft. / 24.7 Ltr |
| Enclosure Weight | 17.5 lbs |
| Height | 14in / 35.56cm |
| Width | 28.5in / 72.39cm |
| Depth | 6.1in / 15.5cm |
| Depth (with Speaker & Grill) | 7.3in / 18.59cm |

Height
14in / 35.56cm

Width
28.5in / 72.39cm

Depth
6.1in / 15.5cm

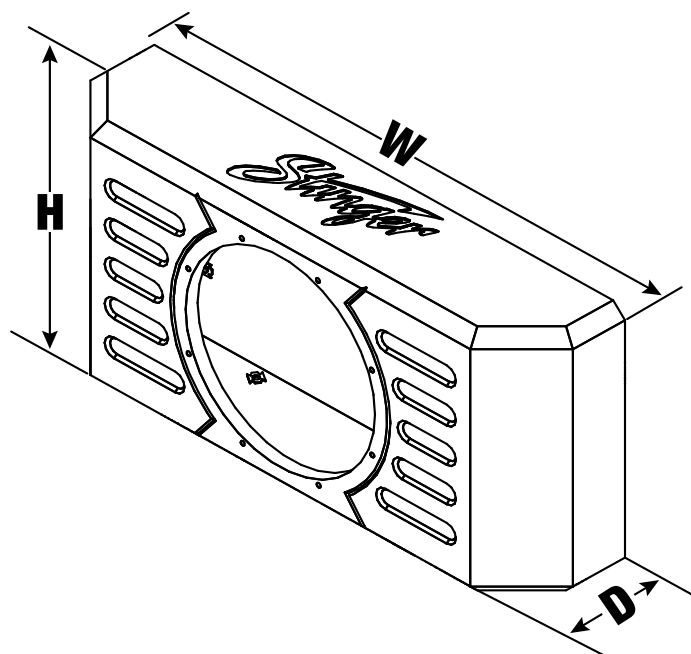

Limited Warranty

Stinger warrants this product to be free of defects in materials and workmanship for a period of one (1) years from the original date of purchase. This warranty is not transferable and applies only to the original purchaser from an authorized Stinger dealer in the United States of America only. Should service be necessary under this warranty for any reason due to manufacturing defect or malfunction, Stinger will (at its discretion), repair or replace the defective product with new or remanufactured product at no charge. Damage caused by the following is not covered under warranty: accident, misuse, abuse, product modification or neglect, failure to follow installation instructions, unauthorized repair attempts, misrepresentations by the seller. This warranty does not cover incidental or consequential damages and does not cover the cost of removing or reinstalling the unit(s). Cosmetic damage due to accident or normal wear and tear is not covered under warranty.

INTERNATIONAL WARRANTIES:

Products purchased outside the United States of America are covered only by that country's Authorized Stinger reseller and not by Stinger. Consumers needing service or warranty information for these products must contact that country's reseller for information.



Stinger is a Power Brand of AAMP Global
15500 Lightwave, Clearwater, Florida 33760
Phone: 888-228-5560

Technical Support

Phone: 727-592-5991

Email: support@stingerelectronics.com

Chat: [stingerelectronics.com](https://www.stingerelectronics.com)

Stinger and the Stinger logo are trademarks or registered trademarks of AAMP Global in the United States and other countries.

AAMP Global is not affiliated with FCA US LLC. Jeep® is a registered trademark of FCA US LLC. The terms OEM, Jeep, Wrangler, and Gladiator all terms are used strictly for identification purposes only. It is not implied that any part listed is a product of, or approved by, Fiat Chrysler Automobiles.