

SRT484F



FEATURES

Maintain control with four dual-stacked burners that go from 20,000 Btu down to a mere breath of flame

Simmer and melt sauces, soups, and marinades easily with the lower tier of the dual-stacked burner

Match other Sub-Zero, Wolf, and Cove products with heavy-gauge stainless steel and signature red infinite control knobs

Control temperature by seamlessly sliding pots or pans across the French top

Cleanup is a snap as sealed, seamless burner pans contain splashes and spills

Move pots and pans effortlessly across the continuous cast-iron grates

Reignites flame automatically with spark ignition system

ACCESSORIES

2-Burner Wok Grate

Filler Trim

S-Grates

Stainless steel, brass or chrome bezels

High altitude conversion kits available

5" and 10" stainless steel risers, and 20" riser with shelf

Signature red, black or stainless steel control knobs

Accessories available through an authorized dealer.

For local dealer information, visit subzero-wolf.com/locator.



KNOB OPTIONS



TOP CONFIGURATION

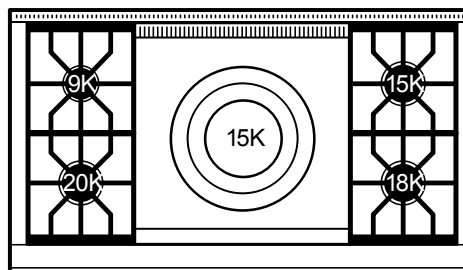

RANGETOP SPECIFICATIONS

- Stainless-steel island trim (included)
- Stainless-steel bezels
- 1 - 9,200 Btu burner
- 1 - 15,000 Btu burner
- 1 - 18,000 Btu burner
- 1 - 20,000 Btu burner
- 1 - French top 15,000 Btu

PRODUCT SPECIFICATIONS

Model	SRT484F
Dimensions	47 7/8"W x 8 1/2"H x 28 1/2"D
Electrical Supply	120 VAC, 60 Hz
Electrical Service	15 amp dedicated circuit
Gas Supply	3/4" ID line
Gas Inlet	1/2" NPT female
Receptacle	3-prong grounding-type

ELECTRICAL

GAS

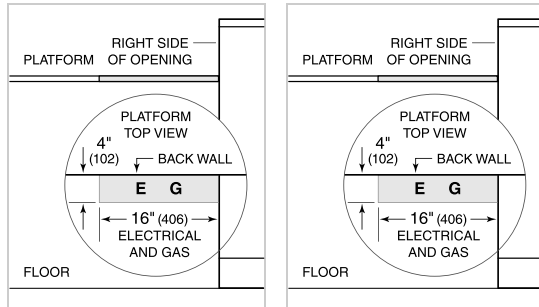

NOTE: Dimensions in parenthesis are in millimeters unless otherwise specified

DIMENSIONS

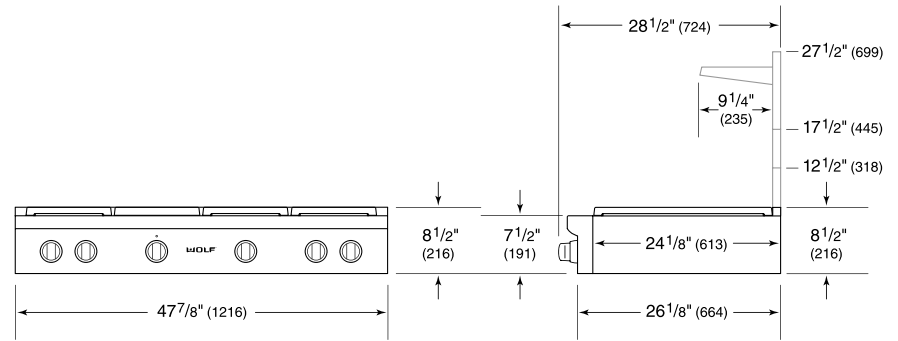

STANDARD INSTALLATION

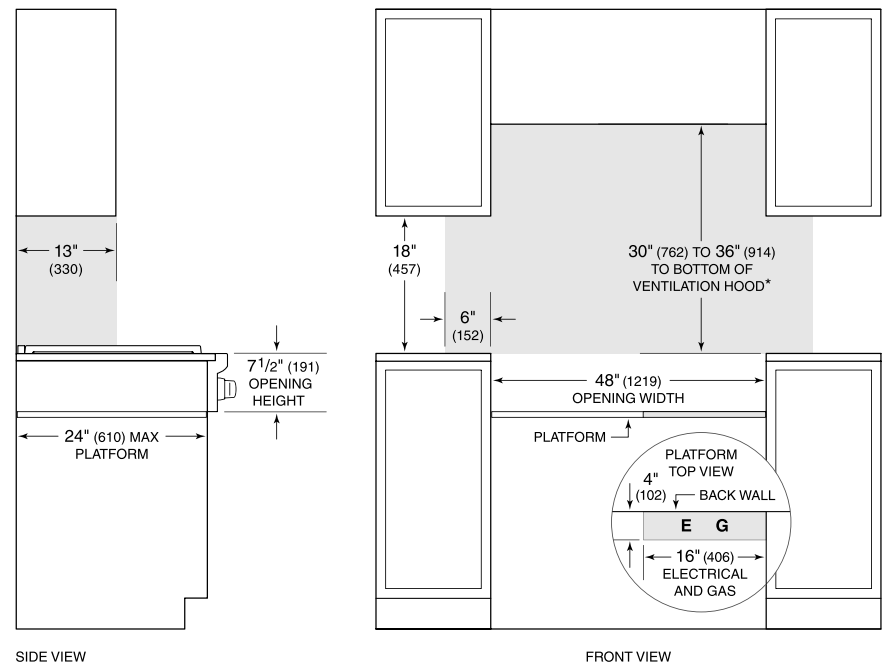

SIDE VIEW

FRONT VIEW

**Without ventilation hood, 36" (914) minimum clearance countertop to combustible materials, 44" (1118) for charbroiler.*

NOTE: Shaded area above countertop indicates minimum clearance to combustible surfaces, combustible materials cannot be located within this area.

Electrical and gas supply located through bottom of platform.

For island installation, 12" (305) minimum clearance back of range to combustible rear wall above countertop.