

The Hisense logo is rendered in a bold, black, sans-serif font. The letters 'H', 's', 'e', and 's' are lowercase, while 'i' and 'n' are uppercase. The logo is positioned in the upper left quadrant of the page, with a large, light gray curved graphic element behind it that sweeps from the top right towards the bottom left.

Hisense

USE AND INSTALLATION MANUAL

**For questions about features, operation / performance,
parts or service, call: 1-877-465-3566**

**Operating hours (EST):
Monday - Friday from 9 a.m. to 9 p.m.
Saturday - Sunday from 9 a.m. to 6 p.m.**

Language: English and Spanish

Table of Contents

Safety Information	3
Pre-Installation	8
Installation	14
Operation	19
Care and Cleaning	24
Troubleshooting	25

Safety Information

We have provided many important safety messages in this manual and on your appliance. Always read and obey all safety messages.



DANGER: This symbol alerts you to a potential hazard, that if not avoided, will result in death or serious injury.



WARNING: This symbol alerts you to a potential hazard, that if not avoided, could result in death or serious injury.



CAUTION: This symbol alerts you to a potential hazard, that if not avoided, may result in minor or moderate injury.



WARNING: Risk of Fire or Explosion. This unit contains flammable refrigerant. Additional safety precautions must be followed.

1. Do not use means to accelerate the defrosting process or to clean, other than those recommended by the manufacturer.
2. The appliance shall be stored in a room without continuously operating ignition sources (for example: open flames, an operating gas appliance or an operating electric heater).
3. Do not pierce or burn refrigerant tubing. Be aware that refrigerants may not contain an odor.
4. Compliance with national gas regulations shall be observed.
5. Keep ventilation openings clear of obstruction.
6. When handling, installing, and operating the appliance, care should be taken to avoid damage to the refrigerant tubing.
7. The maximum refrigerant charge amount is shown on nameplate on the air conditioner.
8. Do not drill holes in the unit.
9. Maintenance, cleaning, and service should only be performed by technicians properly trained and qualified in the use of flammable refrigerants.
10. Dispose of air conditioner in accordance with Federal and Local Regulations. Flammable refrigerants require special disposal procedures. Contact your local authorities for the environmentally safe disposal of your air conditioner.
11. The appliance shall be stored so as to prevent mechanical damage from occurring.
12. The appliance shall be stored in a well-ventilated area where the room size corresponds to the room area as specified for operation.
13. This product contains small parts such as (batteries, battery cover and screws) that may cause suffocation if swallowed by children.
14. Do not place items on the air conditioner or bracket.
15. Do not play with the air conditioner or bracket, especially for children.
16. Do not drink water discharged from the air conditioner, it may contain mold and bacteria that can lead to death if ingested.
17. When the air filter is to be removed, do not touch the metal parts of the unit, it may cause injury.

Explanation of symbols displayed on the unit.

	<p>WARNING This symbol shows that this appliance uses a flammable refrigerant. If the refrigerant is leaked and exposed to an external ignition source, there is a risk of fire.</p>
	<p>CAUTION This symbol shows that the operation manual should be read carefully.</p>
	<p>CAUTION This symbol shows that a service personnel should be handling this equipment with reference to the installation manual.</p>
	<p>CAUTION This symbol shows that information is available such as the operating manual or installation manual.</p>

Safety Information (continued)

IMPORTANT SAFETY INSTRUCTIONS

To reduce the risk of fire, electrical shock or injury when using your air conditioner, follow these basic precautions:

1. Plug into a grounded 3-prong outlet.
2. Do not remove ground prong.
3. Do not use an adapter.
4. Do not use an extension cord.
5. Unplug air conditioner before servicing.
6. Use two or more people to move and install air conditioner.
7. If the SUPPLY CORD is damaged, it must be replaced by the manufacturer, its service agent or similarly qualified persons in order to avoid a hazard.

DISPOSING OF THE UNIT

1. Before throwing out the device, it is necessary to remove the battery cells and dispose or recycle them properly.
2. When you need disposal of the unit consult our dealer. If pipes are removed incorrectly, refrigerant may blow out and come into contact with your skin, causing injury. Releasing refrigerant into the atmosphere also damages the environments.
3. Please recycle or dispose of the product packaging material in an environmentally responsible manner.
4. Never store or ship the air conditioner upside down or sideways to avoid damage to the compressor.
5. This appliance is not intended for use by persons (including children) with reduced physical, sensory or mental capabilities, or lack of experience and knowledge, unless they have been given supervision or instruction concerning use of the appliance by a person responsible for their safety. Children should be supervised to ensure that they do not play with the appliance.
6. The wiring diagram is shown on nameplate on the air conditioner.

At least 10cm air space between left/right sides of window air conditioner and adjacent obstacle, at least 50 cm air space between front/rear sides of window air conditioner and adjacent obstacle, and at least 10 cm air space between top side of window air conditioner and adjacent obstacle should be maintained during normal operation.

Maintenance, service, and repair personnel must be trained according to UL/CSA 60335-2-40 Ed 4.0 Annex HH and possess the required qualifications. Every working procedure that affects safety means shall only be carried out by competent persons according to "Competence of service personnel".

Examples for such working procedures are:

- breaking into the refrigerating circuit;
- opening of sealed components;
- opening of ventilated enclosures.

PRECAUTIONS FOR USING R32 REFRIGERANT

The basic installation work procedures are the same as the conventional refrigerant (R22 or R410A).

However, pay attention to the following:

1. Transport of equipment containing flammable refrigerants

Attention is drawn to the fact that additional transportation regulations may exist with respect to equipment containing flammable gas. The maximum number of pieces of equipment or the configuration of the equipment permitted to be transported together will be determined by the applicable transport regulations.

2. Marking of equipment using signs

Signs for similar appliances used in a work area are generally addressed by local regulations and give the minimum requirements for the provision of safety and/or health signs for a work location.

All required signs are to be maintained and employers should ensure that employees receive suitable and sufficient instruction and training on the meaning of appropriate safety signs and the actions that need to be taken in connection with these signs. The effectiveness of signs should not be diminished by too many signs being placed together. Any pictograms used should be as simple as possible and contain only essential details.

3. Disposal of equipment using flammable refrigerants

See national regulations.

4. Storage of equipment/appliances

The storage of the appliance should be in accordance with the applicable regulations or instructions, whichever is more stringent.

5. Storage of packed (unsold) equipment

Storage package protection should be constructed in such a way that mechanical damage to the equipment inside the package will not cause a leak of the refrigerant charge.

The maximum number of pieces of equipment permitted to be stored together will be determined by local regulations.

Safety Information (continued)

6. Information on servicing

Where electrical components are being changed, they shall be fit for the purpose and to the correct specification. At all times the manufacturer's maintenance and service guidelines shall be followed. If in doubt, consult the manufacturer's technical department for assistance.

The following checks shall be applied to installations using **FLAMMABLE REFRIGERANTS**:

- the actual REFRIGERANT CHARGE is in accordance with the room size within which the refrigerant containing parts are installed;
- the ventilation machinery and outlets are operating adequately and are not obstructed;
- if an indirect refrigerating circuit is being used, the secondary circuit shall be checked for the presence of refrigerant;
- marking to the equipment continues to be visible and legible. Markings and signs that are illegible shall be corrected;
- refrigerating pipe or components are installed in a position where they are unlikely to be exposed to any substance which may corrode refrigerant containing components, unless the components are constructed of materials which are inherently resistant to being corroded or are suitably protected against being so corroded.

For Models employing Flammable Refrigerant, the user instruction shall also contain the following information:

1. Prior to beginning work on systems containing FLAMMABLE REFRIGERANTS, safety checks are necessary to ensure that the risk of ignition is minimised.
2. For repair to the REFRIGERATING SYSTEM, the following shall be completed prior to conducting work on the system.
 - Work shall be undertaken under a controlled procedure so as to minimise the risk of a flammable gas or vapour being present while the work is being performed.
 - All maintenance staff and others working in the local area shall be instructed on the nature of work being carried out. Work in confined spaces shall be avoided.
 - The area shall be checked with an appropriate refrigerant detector prior to and during work, to ensure the technician is aware of potentially toxic or flammable atmospheres. Ensure that the leak detection equipment being used is suitable for use with all applicable refrigerants, i.e. non-sparking, adequately sealed or intrinsically safe.
 - If any hot work is to be conducted on the refrigerating equipment or any associated parts, appropriate fire extinguishing equipment shall be available to hand. Have a dry powder or CO₂ fire extinguisher adjacent to the charging area.
 - No person carrying out work in relation to a REFRIGERATING SYSTEM which involves exposing any pipe work shall use any sources of ignition in such a manner that it may lead to the risk of fire or explosion. All possible ignition sources, including cigarette smoking, should be kept sufficiently far away from the site of installation, repairing, removing and disposal, during which refrigerant can possibly be released to the surrounding space. Prior to work taking place, the area around the equipment is to be surveyed to make sure that there are no flammable hazards or ignition risks. "No Smoking" signs shall be displayed.

Repair and maintenance to electrical components shall include initial safety checks and component inspection procedures. If a fault exists that could compromise safety, then no electrical supply shall be connected to the circuit until it is satisfactorily dealt with. If the fault cannot be corrected immediately but it is necessary to continue operation, an adequate temporary solution shall be used. This shall be reported to the owner of the equipment so all parties are advised.

Initial safety checks shall include:

- that capacitors are discharged: this shall be done in a safe manner to avoid possibility of sparking;
- that no live electrical components and wiring are exposed while charging, recovering or purging the system;
- that there is continuity of earth bonding.

7. Sealed electrical components shall be replaced.

8. Intrinsically safe components must be replaced.

9. Cabling

Check that cabling will not be subject to wear, corrosion, excessive pressure, vibration, sharp edges or any other adverse environmental effects. The check shall also take into account the effects of aging or continual vibration from sources such as compressors or fans.

10. Detection of flammable refrigerants

Under no circumstances shall potential sources of ignition be used in the searching for or detection of refrigerant leaks. A halide torch (or any other detector using a naked flame) shall not be used.

Safety Information (continued)

11. Leak detection methods

The following leak detection methods are deemed acceptable for all refrigerant systems.

Electronic leak detectors may be used to detect refrigerant leaks but, in the case of FLAMMABLE REFRIGERANTS, the sensitivity may not be adequate, or may need re-calibration. (Detection equipment shall be calibrated in a refrigerant-free area.) Ensure that the detector is not a potential source of ignition and is suitable for the refrigerant used. Leak detection equipment shall be set at a percentage of the LFL of the refrigerant and shall be calibrated to the refrigerant employed, and the appropriate percentage of gas (25% maximum) is confirmed.

Leak detection fluids are also suitable for use with most refrigerants but the use of detergents containing chlorine shall be avoided as the chlorine may react with the refrigerant and corrode the copper pipe-work.



NOTE: Examples of leak detection fluids are

- bubble method,
- fluorescent method agents.

If a leak is suspected, all naked flames shall be removed / extinguished.

If a leakage of refrigerant is found which requires brazing, all of the refrigerant shall be recovered from the system, or isolated (by means of shut off valves) in a part of the system remote from the leak.

12. Removal and evacuation

When breaking into the refrigerant circuit to make repairs - or for any other purpose - conventional procedures shall be used.

However, for flammable refrigerants it is important that best practice be followed, since flammability is a consideration.

The following procedure shall be adhered to:

- safely remove refrigerant following local and national regulations;
- evacuate;
- purge the circuit with inert gas (optional for A2L);
- evacuate (optional for A2L);
- continuously flush or purge with inert gas when using flame to open circuit;
- open the circuit.

The refrigerant charge shall be recovered into the correct recovery cylinders if venting is not allowed by local and national codes. For appliances containing flammable refrigerants, the system shall be purged with oxygen - free nitrogen to render the appliance safe for flammable refrigerants. This process might need to be repeated several times. Compressed air or oxygen shall not be used for purging refrigerant systems.

For appliances containing flammable refrigerants, refrigerants purging shall be achieved by breaking the vacuum in the system with oxygen - free nitrogen and continuing to fill until the working pressure is achieved, then venting to atmosphere, and finally pulling down to a vacuum (optional for A2L). This process shall be repeated until no refrigerant is within the system (optional for A2L). When the final oxygen - free nitrogen charge is used, the system shall be vented down to atmospheric pressure to enable work to take place.

The outlet for the vacuum pump shall not be close to any potential ignition sources, and ventilation shall be available.

13. Charging procedures

In addition to conventional charging procedures, the following requirements shall be followed.

- Ensure that contamination of different refrigerants does not occur when using charging equipment. Hoses or lines shall be as short as possible to minimise the amount of refrigerant contained in them.
- Cylinders shall be kept in an appropriate position according to the instructions.
- Ensure that the REFRIGERATING SYSTEM is earthed prior to charging the system with refrigerant.
- Label the system when charging is complete (if not already).
- Extreme care shall be taken not to overfill the REFRIGERATING SYSTEM.

Prior to recharging the system, it shall be pressure-tested with the appropriate purging gas. The system shall be leak-tested on completion of charging but prior to commissioning. A follow up leak test shall be carried out prior to leaving the site.

Safety Information (continued)

14. Decommissioning

Before carrying out this procedure, it is essential that the technician is completely familiar with the equipment and all its detail. It is recommended good practice that all refrigerants are recovered safely. Prior to the task being carried out, an oil and refrigerant sample shall be taken in case analysis is required prior to re-use of recovered refrigerant. It is essential that electrical power is available before the task is commenced.

- a) Become familiar with the equipment and its operation.
- b) Isolate system electrically.
- c) Before attempting the procedure, ensure that:
 - mechanical handling equipment is available, if required, for handling refrigerant cylinders;
 - all personal protective equipment is available and being used correctly;
 - the recovery process is supervised at all times by a competent person;
 - recovery equipment and cylinders conform to the appropriate standards.
- d) Pump down refrigerant system, if possible.
- e) If a vacuum is not possible, make a manifold so that refrigerant can be removed from various parts of the system.
- f) Make sure that cylinder is situated on the scales before recovery takes place.
- g) Start the recovery machine and operate in accordance with instructions.
- h) Do not overfill cylinders (no more than 80% volume liquid charge).
- i) Do not exceed the maximum working pressure of the cylinder, even temporarily.
- j) When the cylinders have been filled correctly and the process completed, make sure that the cylinders and the equipment are removed from site promptly and all isolation valves on the equipment are closed off.
- k) Recovered refrigerant shall not be charged into another REFRIGERATING SYSTEM unless it has been cleaned and checked.

15. Labelling

Equipment shall be labelled stating that it has been de-commissioned and emptied of refrigerant. The label shall be dated and signed. For appliances containing FLAMMABLE REFRIGERANTS, ensure that there are labels on the equipment stating the equipment contains FLAMMABLE REFRIGERANT.

16. Recovery

When removing refrigerant from a system, either for servicing or decommissioning, it is recommended good practice that all refrigerants are removed safely.

When transferring refrigerant into cylinders, ensure that only appropriate refrigerant recovery cylinders are employed. Ensure that the correct number of cylinders for holding the total system charge is available. All cylinders to be used are designated for the recovered refrigerant and labelled for that refrigerant (i.e. special cylinders for the recovery of refrigerant). Cylinders shall be complete with pressure-relief valve and associated shut-off valves in good working order. Empty recovery cylinders are evacuated and, if possible, cooled before recovery occurs.

The recovery equipment shall be in good working order with a set of instructions concerning the equipment that is at hand and shall be suitable for the recovery of the flammable refrigerant. If in doubt, the manufacturer should be consulted. In addition, a set of calibrated weighing scales shall be available and in good working order. Hoses shall be complete with leak-free disconnect couplings and in good condition.

The recovered refrigerant shall be processed according to local legislation in the correct recovery cylinder, and the relevant waste transfer note arranged. Do not mix refrigerants in recovery units and especially not in cylinders.

If compressors or compressor oils are to be removed, ensure that they have been evacuated to an acceptable level to make certain that flammable refrigerant does not remain within the lubricant. The compressor body shall not be heated by an open flame or other ignition sources to accelerate this process. When oil is drained from a system, it shall be carried out safely.

Pre-Installation

ELECTRICAL REQUIREMENTS



DANGER: ELECTRICAL SHOCK HAZARD

1. Plug into a grounded 3-prong outlet.
2. Do not remove ground prong.
3. Do not use an adapter.
4. Do not use an extension cord.
5. Failure to follow these instructions can result in death, fire, or electrical shock.



RECOMMENDED GROUNDING METHOD

This air conditioner must be grounded. This air conditioner is equipped with a power supply cord with a three-prong grounding plug. The cord must be plugged into a three-prong outlet, grounded in accordance with all local codes and ordinances. If a grounded outlet is not available, it is the customer's responsibility to have a properly grounded three-prong outlet installed by a qualified electrical installer.

It is the customer's responsibility:

1. To contact a qualified electrical installer.
2. To assure that the electrical installation is adequate and conforms to the Nation Electrical Code, ANSI/NFPA 70-last edition, and all local codes and ordinances.

Copies of the standards listed may be obtained from:

National Fire Protection Association

1 Batterymarch Park

Quincy, Massachusetts U.S.

02169-7471

www.nfpa.org

WIRING REQUIREMENT

Power supply	Model	Time-delay fuse (or circuit breaker)
115V 103.5V min. 126.5V max.	8K BTU cooling only	13A
	12K BTU cooling only	15A

ELECTRONIC WORK



WARNING: Before performing any electrical or wiring work, turn off the main power to the system.





NOTE: The cographs are for explanation purpose only. You machine may be slightly different. The actual shape shall prevail.

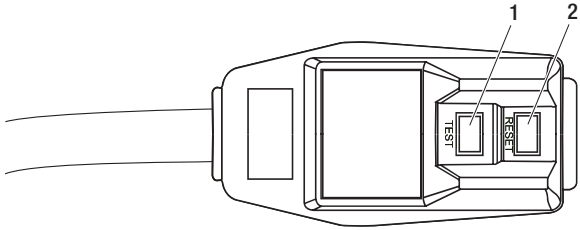

Pre-Installation (continued)

POWER SUPPLY CORD



 **NOTE:** Your air conditioner's device may differ from the one shown. This room air conditioner is equipped with a power supply cord required by UL. This power supply cord contains state-of-the-art electronics that sense leakage current. If the cord is crushed, the electronics detect leakage current and power will be disconnected in a fraction of a second.

To test your power supply cord:

1. Plug power supply cord into a grounded 3-prong outlet.
2. Press RESET (2) (on some devices, a green light will turn on).
3. Press TEST (1) and listen for click. The RESET button will trip and on some devices, a green light will turn off.
4. Press and release RESET (2) and listen for click. The RESET button will latch, and on some devices, a green light will turn on. The power supply cord is ready for operation.

NOTE:

The RESET button must be pushed in for proper operation.

-  1. The power supply cord must be replaced if it fails to trip when the test button is pressed or fails to reset.
2. Do not use the power supply cord as an off/on switch. The power supply cord is designed as a protective device.
3. A damaged power supply cord must be replaced with a new power supply cord obtained from the product manufacturer and must not be repaired.
4. The power supply cord contains no user serviceable parts. Opening the tamper-resistant case voids all warranty and performance claims.

PLANNING INSTALLATION

Gather the required tools and parts before starting installation. Read and follow the instructions provided with any tools listed here.

TOOLS REQUIRED

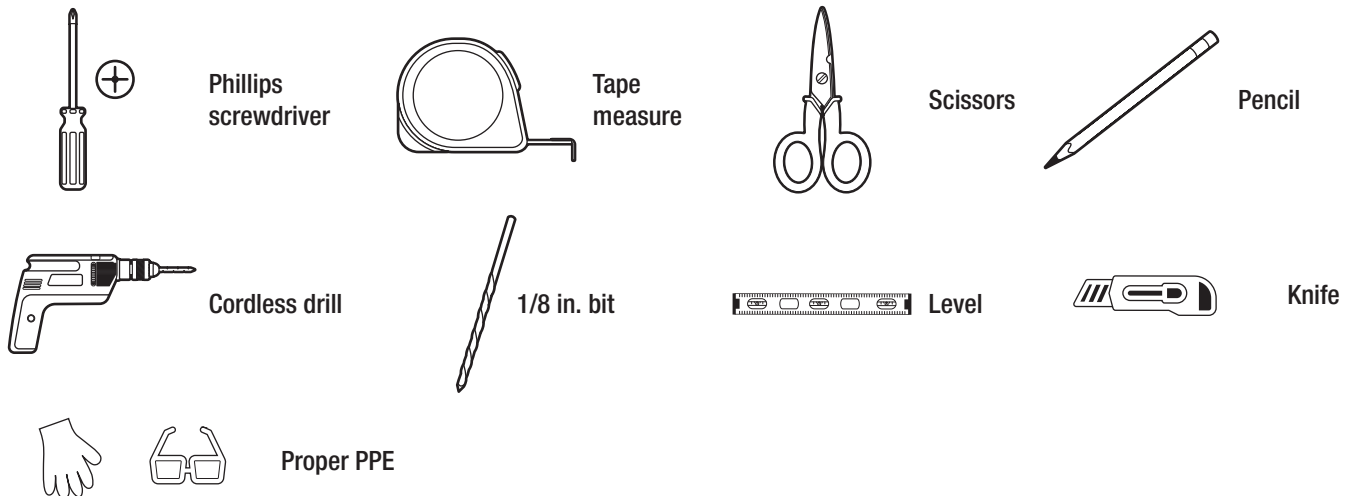

Pre-Installation (continued)

HARDWARE INCLUDED

Part	Description	Quantity	Sketch Map
A1	Adhesive seal (gray)	1	
A2	Adhesive seal (black-long)	1	
A3	Adhesive seal (black-short)	1	
BB	Foam seal (gray)	1	
CC	Screw bolt	2	
DD	1/2" screw	6	
EE	3/8" screw	6	
FF	3/4" screw	11	
GG	Short side curtain (left/right)	1+1	
G1	Wide side curtain (left/right)	1+1	
G2	Spare curtain (left/right)	1	
G3	Eva foam (white)	2	

Part	Description	Quantity	Sketch Map
H1	Main bracket	1	
H2	Extension arm (short)	1	
H3	Extension arm (long)	2*	
H4	Sash lock (for air conditioner)	2	
H5	Back plate	2	
II	Wooden window adapter	1	
JJ	Sash lock (for window)	1	
KK	Air conditioner	1	
LL	Remote control	1	
MM	Batteries (standard AAA 1.5Volt)	2	

* One of the Extension arm (long) has been installed on the Main bracket to demonstrate how to insert or remove. Indicates additional hardware provided in separate bags for certain models.

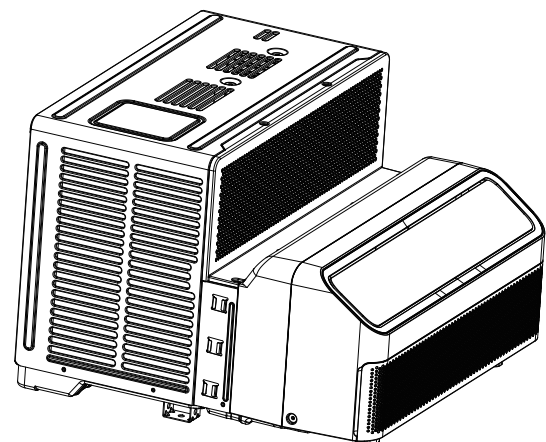
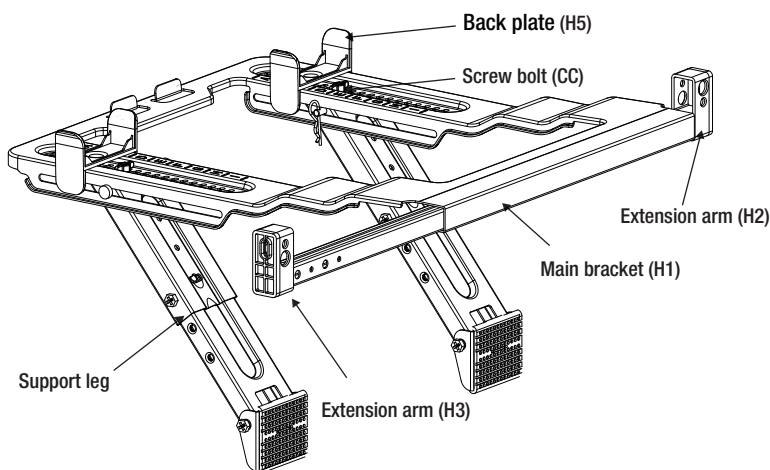

NOTE: All the illustrations in the manual are for explanation purpose only. The actual installation may vary.

Pre-Installation (continued)

UNPACK THE AIR CONDITIONER



WARNING

Excessive Weight Hazard

1. Use two or more people to move and install air conditioner. Failure to do so can result in back or other injury.
2. You must use the supplied parts and use proper installation procedures as described in these instructions when installing the air conditioner.
3. Be careful to avoid cuts from sharp metal edge. Please wear cut-resistant gloves. Support bracket should only be used for its intended purpose. If not, the warranty will be voided.

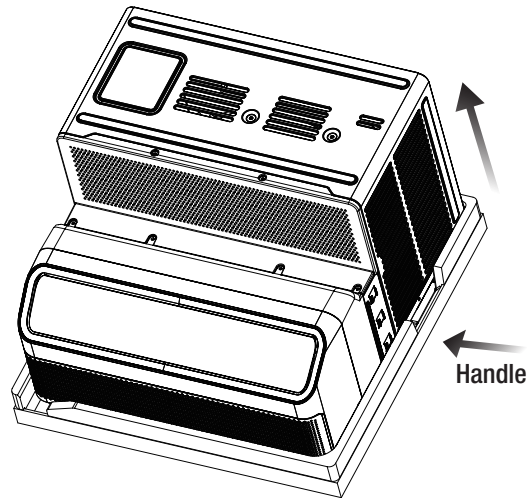
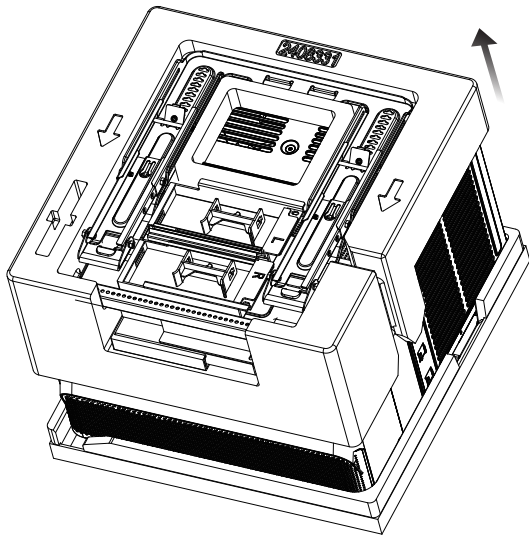

Remove packaging materials

1. Remove and dispose of recycle packaging materials. Remove tape and glue residue from surfaces before turning on the air conditioner. Rub a small amount of liquid dish soap over the adhesive with your fingers. Wipe with warm water and dry.
2. Do not use sharp instruments, rubbing alcohol, flammable fluids, or abrasive cleaners to remove tape or glue. These products can damage the surface of your air conditioner.
3. Remove main bracket and other hardware from the packaging material.
4. Tack out the power supply cord, then move the packaging on the top of the air conditioner.
5. Place both hands in the positions indicated by the arrows and remove the air conditioner from the base of the package.

Pre-Installation (continued)

LOCATION REQUIREMENTS

Before You Begin

Read these instructions completely and carefully.



IMPORTANT: Save these instructions for local inspector's use. Observe all governing codes and ordinances.



NOTE: Installer, be sure to leave these instructions with the Consumer.
Consumer, keep these instructions for future reference.

1. Completion time: Around 20 min.
2. We recommend that two people install this product.
3. Proper installation is the responsibility of the installer.
4. Product failure due to improper installation is not covered under the warranty.
5. You **MUST** use all supplied parts and use proper installation procedures as described in these instructions when installing this air conditioner.

Check the location where air conditioner will be installed. Proper installation is your responsibility. Make sure you have everything necessary for correct installation.

The location should provide:

1. Do not use an extension cord. The appliance shall be installed in accordance with national wiring regulations.
2. Keep the air outlet unobstructed to allow cool air to circulate freely throughout the room.
3. Check and ensure the window opening is large enough to properly accommodate the air conditioner.



NOTE: Cabinet louvers (A-B-C-D) must not be obstructed. Air must be able to pass freely through the cabinet louvers.

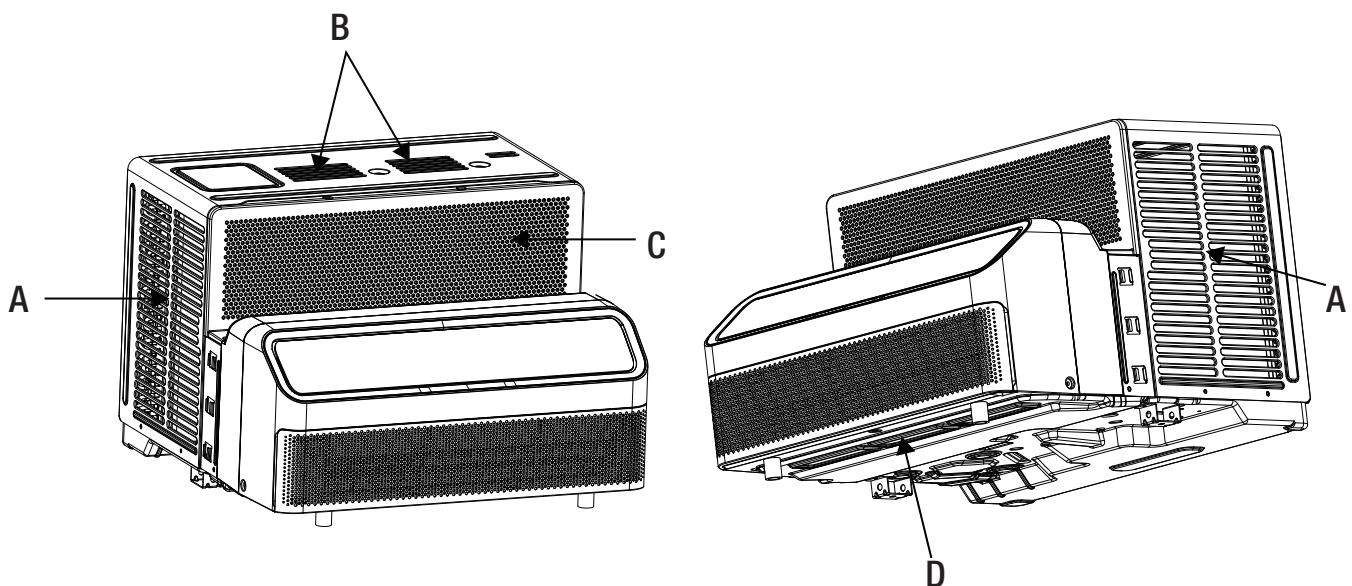

Pre-Installation (continued)

WINDOW OPENING MEASUREMENTS

1. These instructions are for a standard single or double-hung window.
2. All supporting parts must be secured to firm wood, masonry or vinyl-clad.
3. Aluminum house wiring may present special problems-consult a qualified electrician.
4. The electrical outlet must be within reach of the power cord.
5. Follow the dimensions in the table and illustration for your model.

Different type of Windows:

Determine whether the windowsill is flat or has a lip.

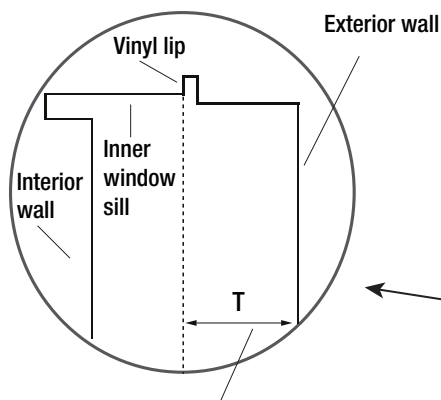

NOTE: Hisense bracket works on walls with thickness 3 to 10.9 inches from inside of window to outside wall.

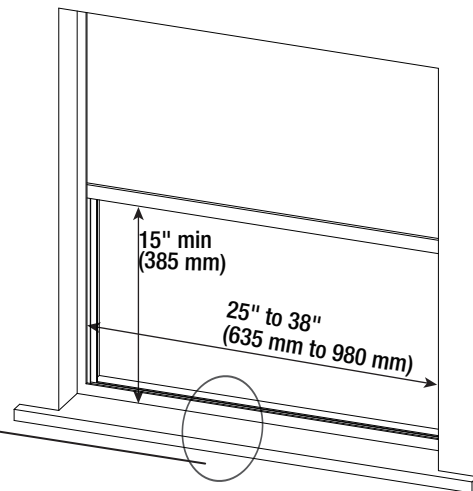

Lip window

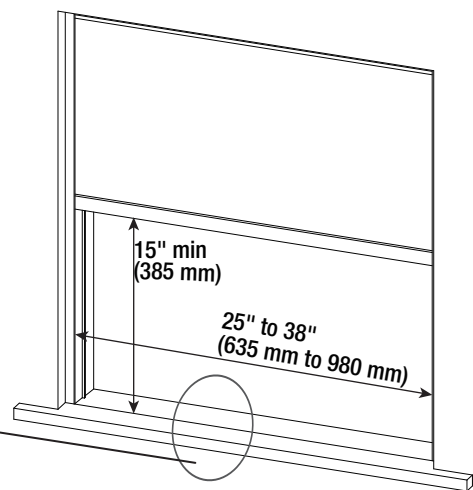
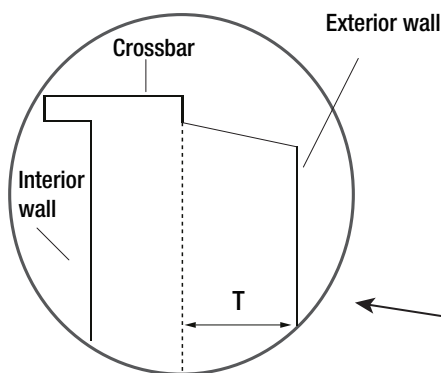

Wooden window



NOTE:
Install the bracket according to the type of window sill.

Installation

1 Install Support Bracket (for Lip Window)

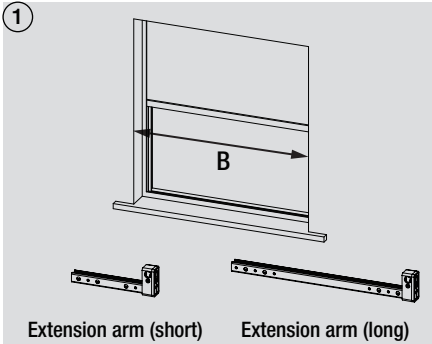

Select the proper extension arm based on the width (B) of the window. Use Extension arm (short) for 25-30.7" windows, and Extension arm (long) for 30.7-38" windows.

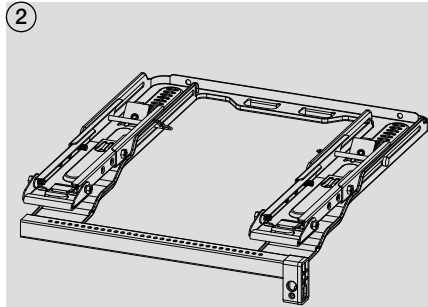

Remove the tape from the bracket (H1) and flip it over.

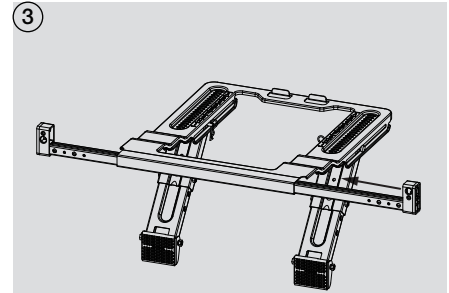

Insert the proper extension arm in the bracket.

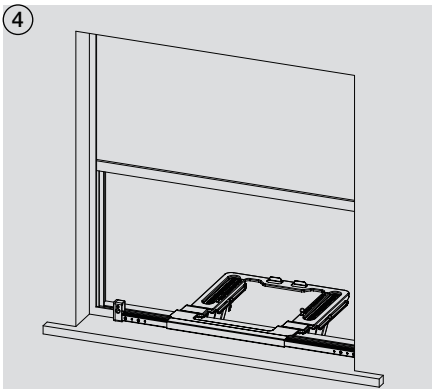

Install support bracket into the opening window. Ensure the main support is on the interior side of the lip.

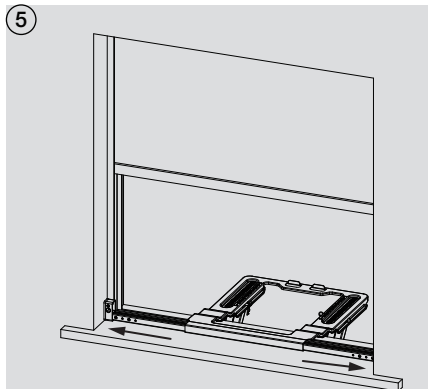

Slide the extension arm out until it contacts the window casing. Repeat on the other side.

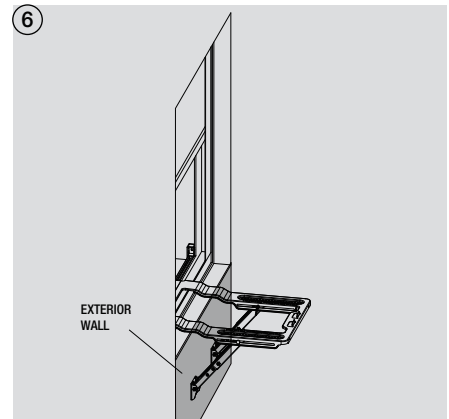

Adjust the legs until they rest against the wall on the outside.

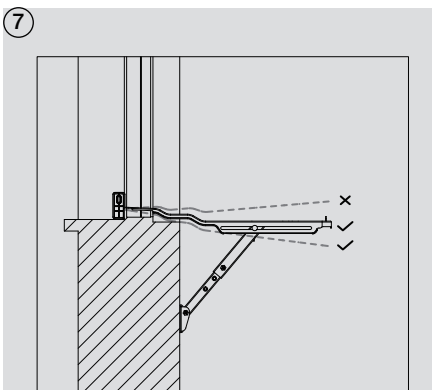

Ensure the bracket is level or angled slightly towards the outside.

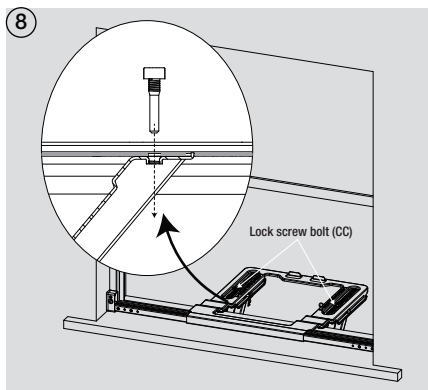

Align the two support legs according to the markings on the support bracket. lock screw bolts (CC) and fasten the legs to the bracket.

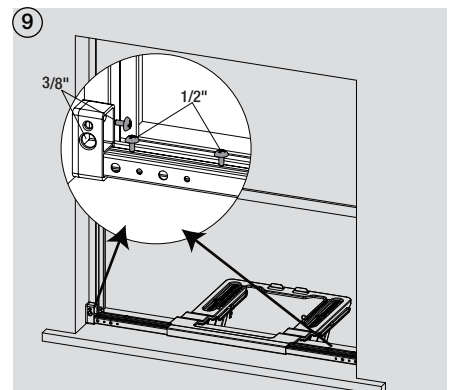

Secure support bracket to the windowsill by drilling 3/8" and 1/2" type screws (DD and EE).

Installation (continued)

1 Install Support Bracket (for wooden window)

1

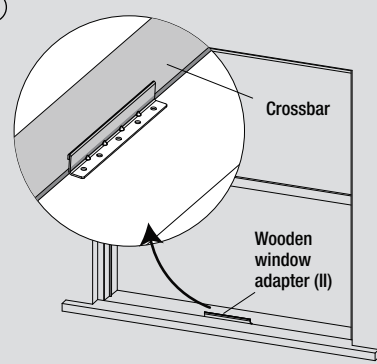

Crossbar
Wooden window adapter (II)

The wooden window adapter is backed against the crossbar of the window sill, flush with the inside of the window frame on both sides.

2

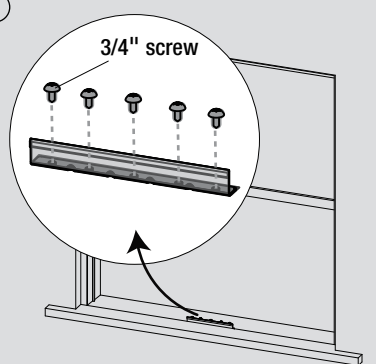

3/4" screw

Secure the wooden window adapter to the window sill using 3/4" (FF) screws.

3

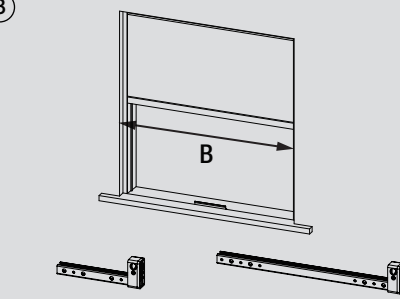

Extension arm (short) Extension arm (long)

Select the proper extension arm based on the width (B) of the window. Use Extension arm (short) for 25-30.7" windows, and Extension arm (long) for 30.7-38" windows.

4

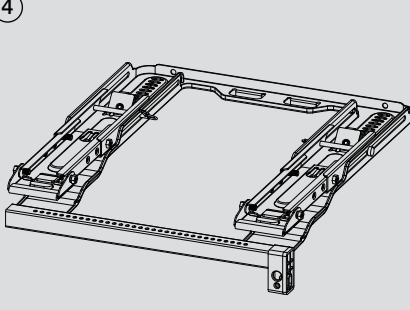

Remove the tape from the bracket (H1) and flip it over.

5

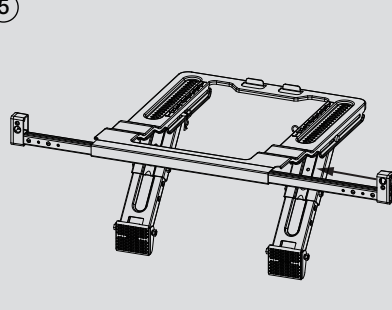

Insert the proper extension arm in the bracket.

6

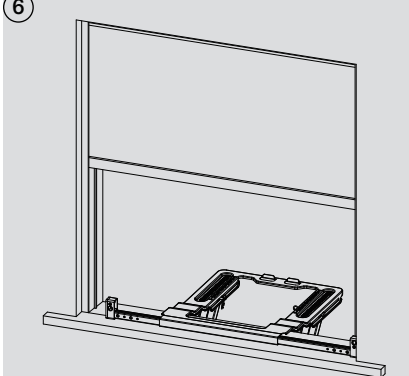

Install support bracket into the opening window. Ensure the main support is on the interior side of the adapter.

7

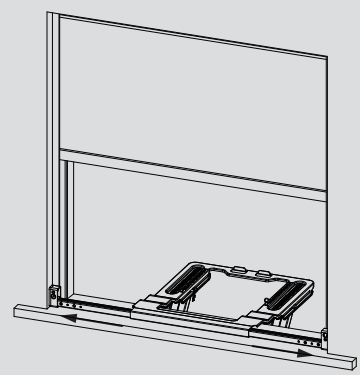

Slide the extension arm out until it contacts the window casing. Repeat on the other side.

8

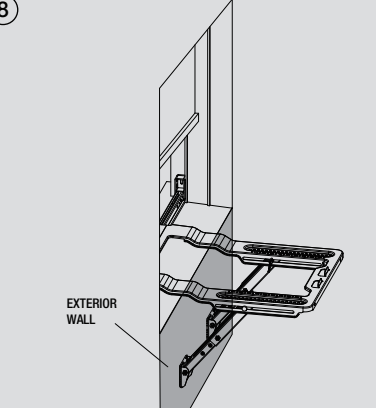

EXTERIOR WALL

Adjust the legs until they rest against the wall on the outside.

9

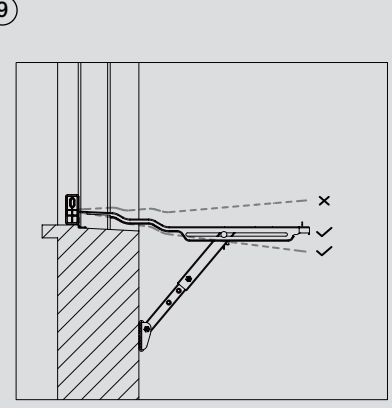

Ensure the bracket is level or angled slightly towards the outside.

Installation (continued)

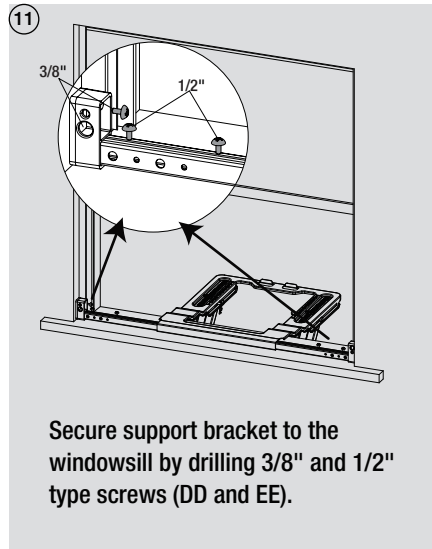
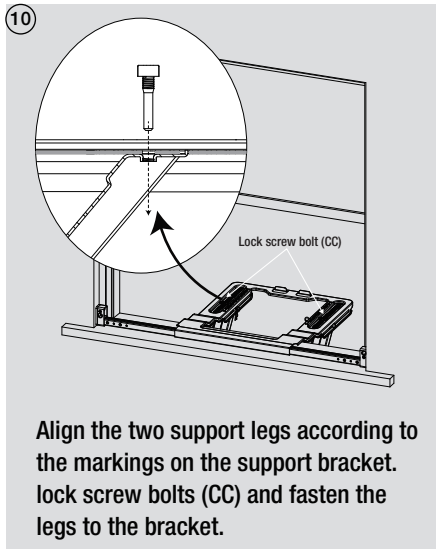

1 Install Support Bracket (for Thick Walls)

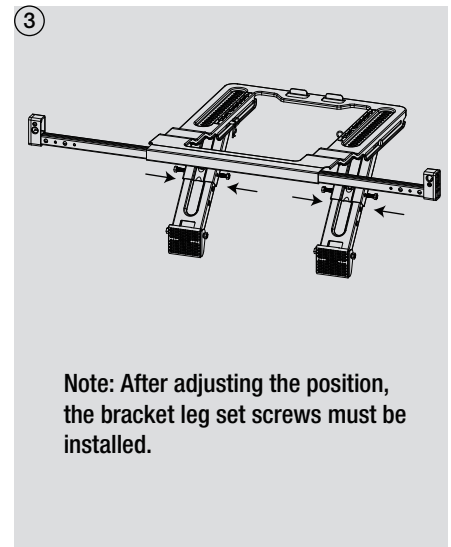
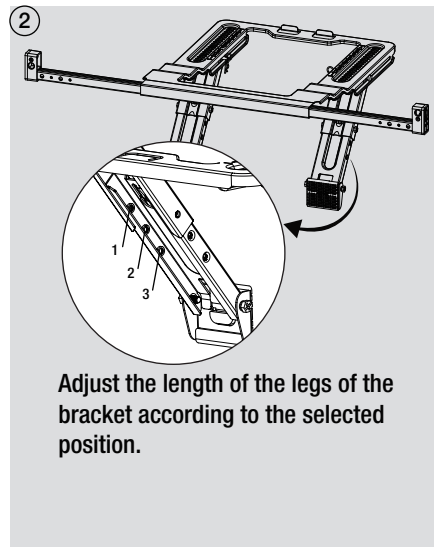
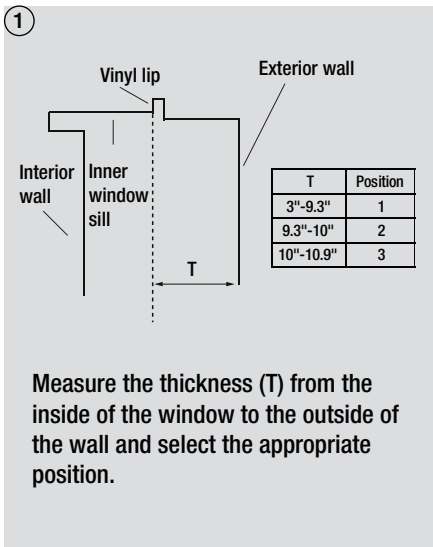

Installation (continued)

2 Placing Air Conditioner in Window

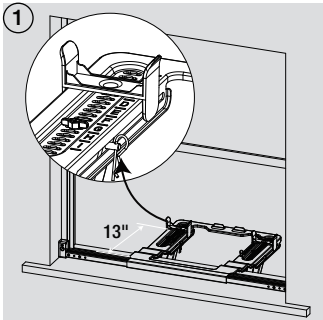

Back plates (H5) mount to both sides of the support bracket, positioned >13" from its indoor edge.

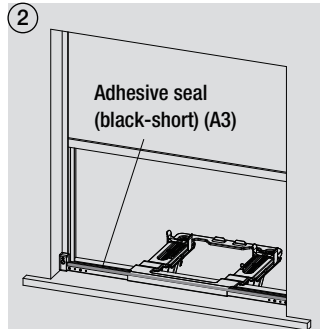

Attach the adhesive seal (black-short) (A3) to the top of the extension arms.

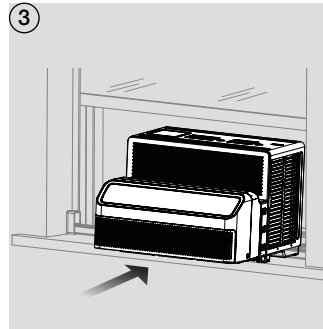

Place the AC unit on the bracket. Ensure it is centered in the support bracket.

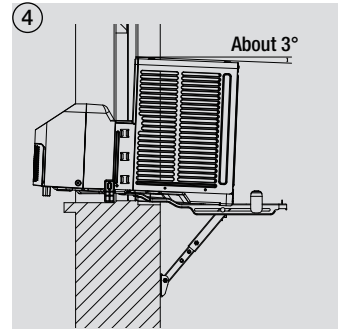

The air conditioner is tilted about 3° toward outside of the room.

NOTES:



1. Handle air conditioner gently.
2. Be sure your air conditioner does not fall out of the opening during installation or removal.
3. Do not block the louvers in the front panel.
4. Do not block the louvers on the outside of the air conditioner.
5. Your model may differ from the one shown.

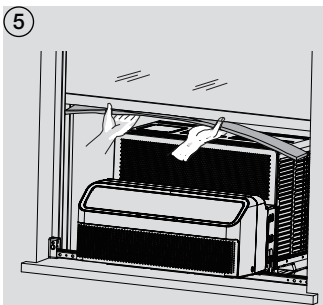

Remove the backing from the adhesive seal (gray) (A1) and attach the seal to the bottom of the lower window sash.

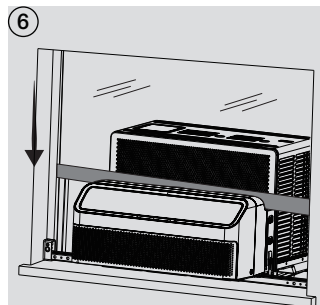

Carefully close the window down into the top groove of the air conditioner.

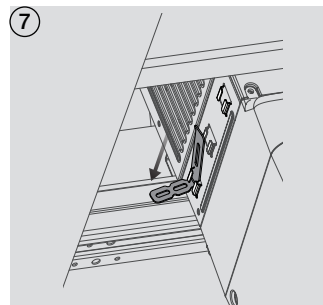

Insert the Sash lock (for air conditioner) into both sides of the air conditioner.

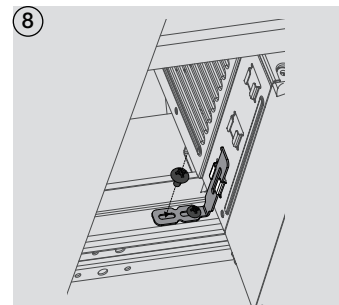

Secure it with 3/8" or 3/4" type screws (EE or FF).

3 Attaching Side Curtains to Window

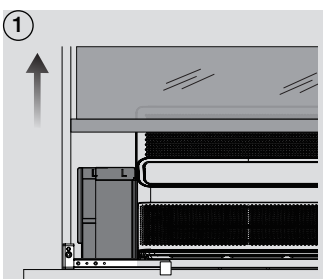

Install Short side curtain (left and right) into the air conditioner, from top to bottom. Repeat for the right curtain.

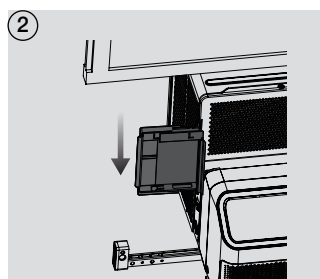

Measure the gap between the unit and the window frame. Select the appropriate side curtain according to the table below:

Less than 3.5" (90 mm):	Spare curtain (G2)
3.5" – 6.5" (90–165 mm):	Short side curtain (GG)
Greater than 6.5" (165 mm):	Wide side curtain (G1)

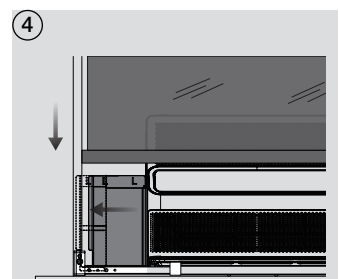
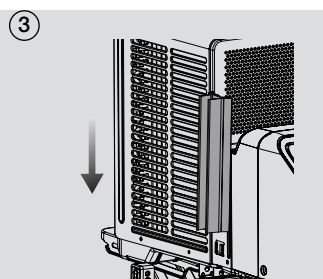

Open side curtains (left and right) until touch the side of window. Carefully close the window down.

Installation (continued)

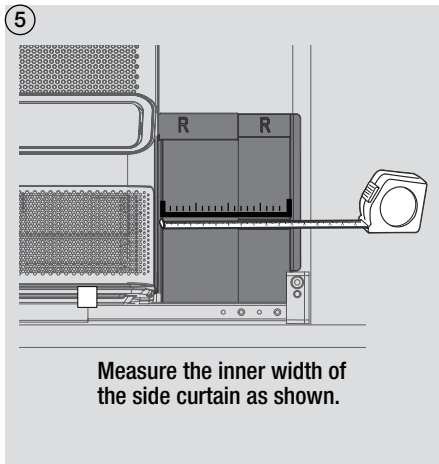

Measure the inner width of the side curtain as shown.

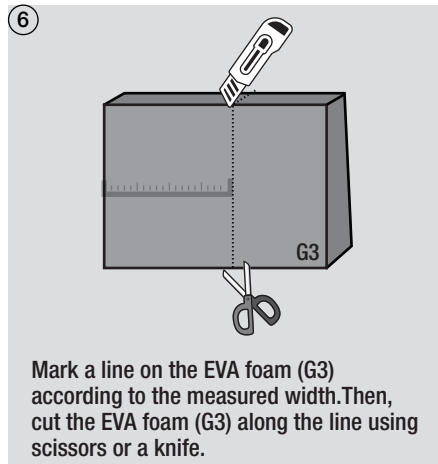

Mark a line on the EVA foam (G3) according to the measured width. Then, cut the EVA foam (G3) along the line using scissors or a knife.

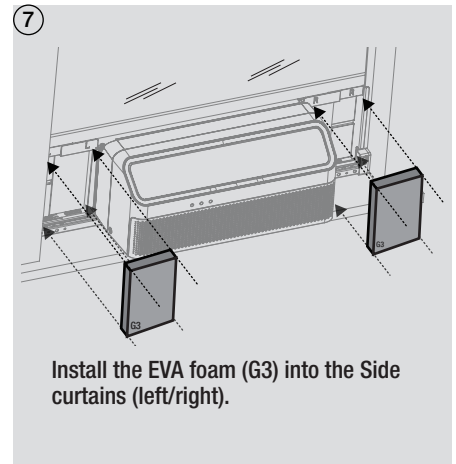

Install the EVA foam (G3) into the Side curtains (left/right).

4 Completing Installation

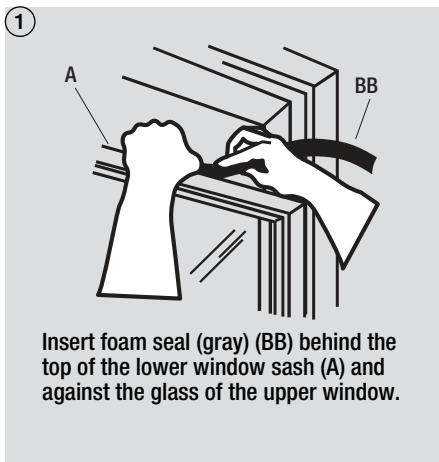

Insert foam seal (gray) (BB) behind the top of the lower window sash (A) and against the glass of the upper window.

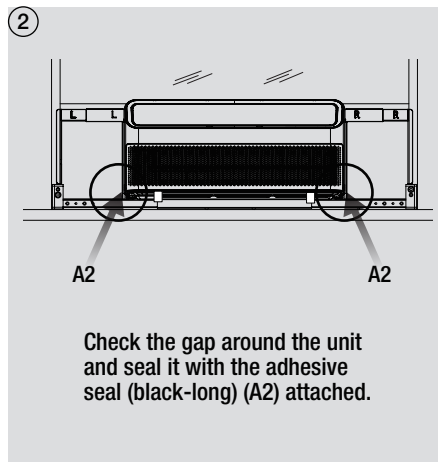

Check the gap around the unit and seal it with the adhesive seal (black-long) (A2) attached.

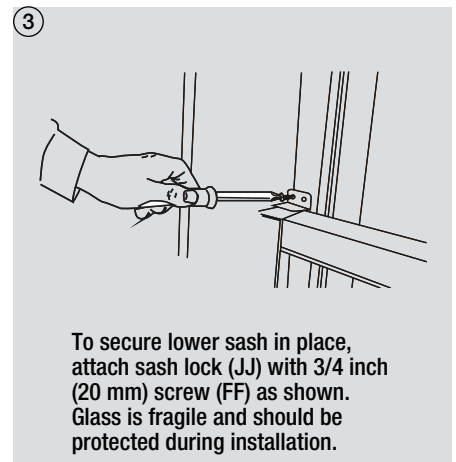

To secure lower sash in place, attach sash lock (JJ) with 3/4 inch (20 mm) screw (FF) as shown. Glass is fragile and should be protected during installation.

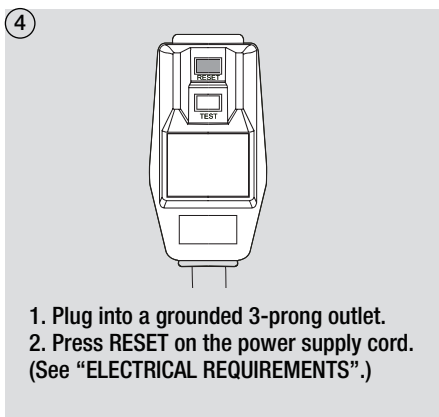

DANGER: ELECTRICAL SHOCK HAZARD

1. Plug into a grounded 3-prong outlet.
2. Do not remove ground prong.
3. Do not use an adapter.
4. Do not use an extension cord.
5. Failure to follow these instructions can result in death, fire, or electrical shock.

Operation

AIR CONDITIONER USE

IMPORTANT:



1. If you turn off the air conditioner, wait at least 3 minutes before turning it back on. This prevents the air conditioner from blowing a fuse or tripping a circuit breaker.
2. In the event of a power failure, your air conditioner will operate at the previous settings when the power is restored.

Optimal operating limits for the air conditioner in Cool mode:

Cool mode operation	Indoor: 62.6-89.6 °F (17-32 °C), ≤ 80% RH
	Outdoor: 64.4-109.4 °F (18-43 °C), ≤ 80% RH

1. Operating your air conditioner properly helps you to obtain the best possible results.
2. This section explains proper air conditioner operation.

1 Using the Control Panel

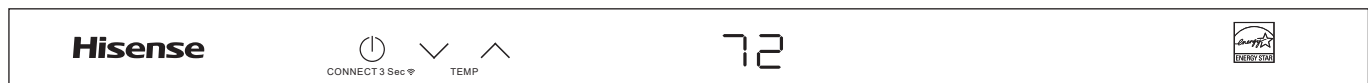

ON/OFF SETTINGS

1. Press the POWER button to turn on the air conditioner.
2. Press and hold for three seconds to activate WiFi pairing mode. (with WIFI model only)







NOTE:

When the air conditioner is turned on for the first time after it is plugged in, the display will show the current set temperature and will run in the ECO control.

Press and hold the POWER button for 3 seconds to enter WiFi pairing mode. (valid for some models)



TEMPERATURE SETTINGS

1. Press the UP  button to raise the temperature. Each time you press or hold the UP  button, the temperature will go up 1 °F (1 °C) until it reaches 86 °F (30 °C).
2. Press the DOWN  button to lower the temperature. Each time you press or hold the DOWN  button, the temperature will go down 1 °F (1 °C) until it reaches 61 °F (16 °C).

Operation (continued)

2 Using the Remote Control

INSERT THE BATTERIES

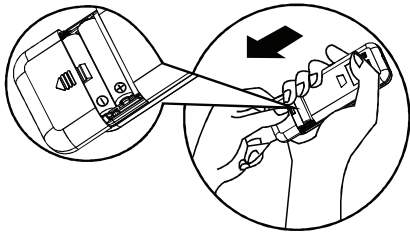

1. Remove the battery cover along the arrow direction.

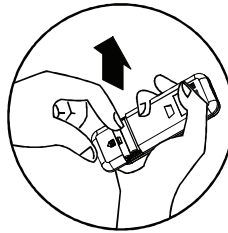

2. Insert new batteries making sure that the (+) and (-) of battery are matched correctly.

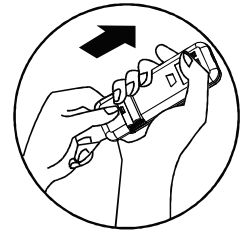

3. Re-attach the cover by sliding it back into position.

NOTE: 1. Use 2 standard AAA (1.5 volt) batteries. Do not use rechargeable batteries.

2. Replace batteries with new ones of the same type when the display becomes dim, or after 6 months.

3. When replacing batteries, always replace both batteries with new batteries. Do not mix old and new batteries.

4. Do not mix alkaline, standard (carbon-zinc), or rechargeable (ni-cd, ni-mh, etc) batteries.

5. If the air conditioner will not be used for an extended period of time, remove the batteries from the remote.



1. Do not use the remote if the batteries have leaked.

2. The chemicals in batteries could cause burns or other health hazards.

3. Do not dispose of batteries in a fire. Batteries may explode or leak.

HOW TO USE

1. To operate the room air conditioner, aim the remote control at the signal receptor. The remote control will operate the air conditioner at a distance of up to 23' (7m) when pointed at the signal receptor.

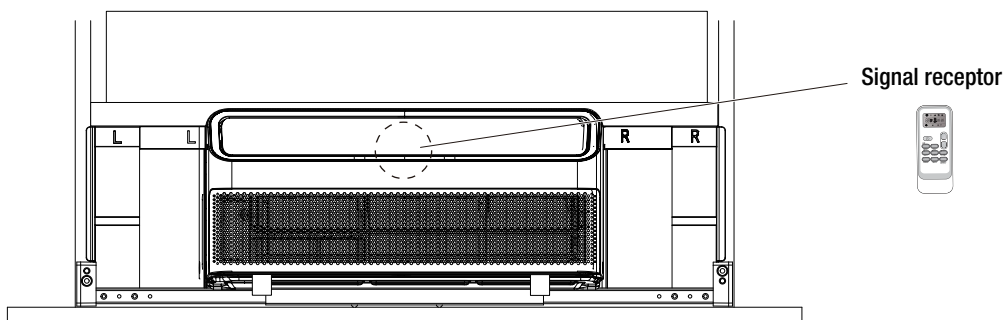

Operation (continued)

BUTTON AND FUNCTION

NOTE: Remote control may differ in appearance.
Heating indicator is not available on this models.

NOTE: Press and hold the MODE button on the remote for 5 seconds to switch the temperature display from degrees Fahrenheit (°F) to degrees Celsius (°C).

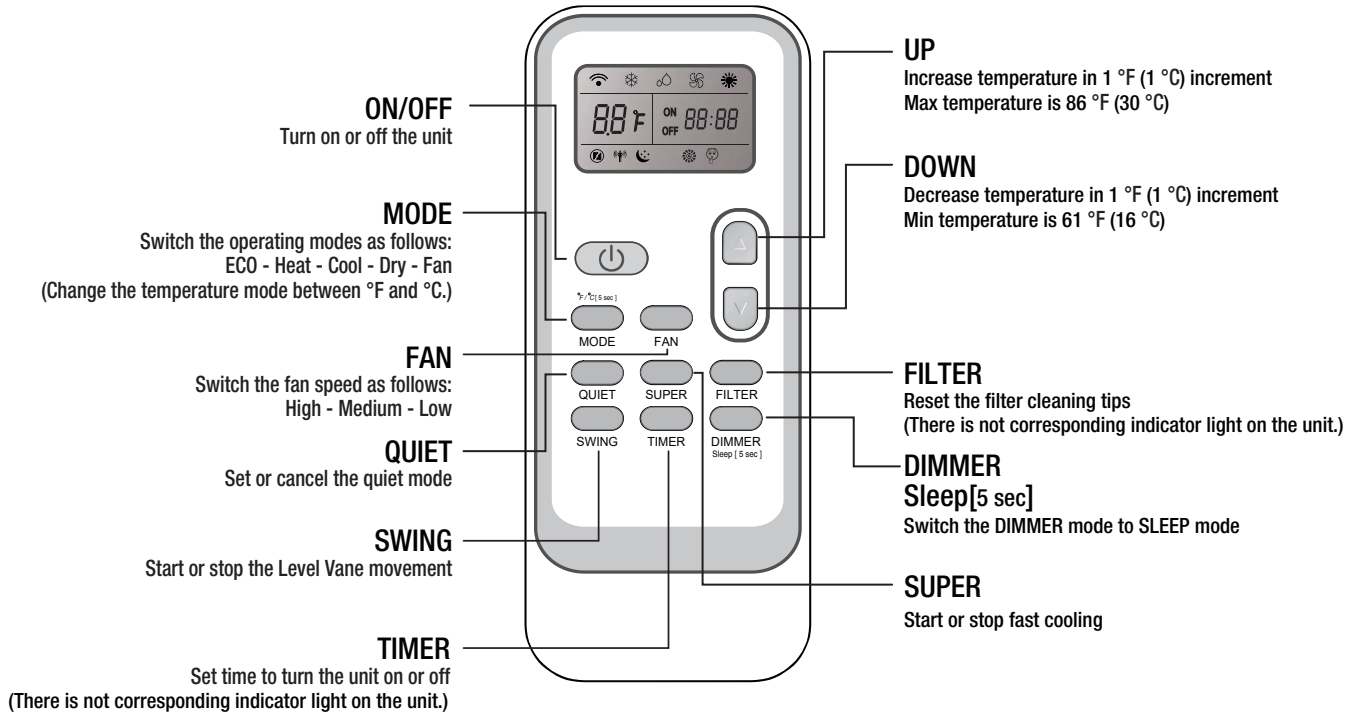

INDICATION SYMBOLS

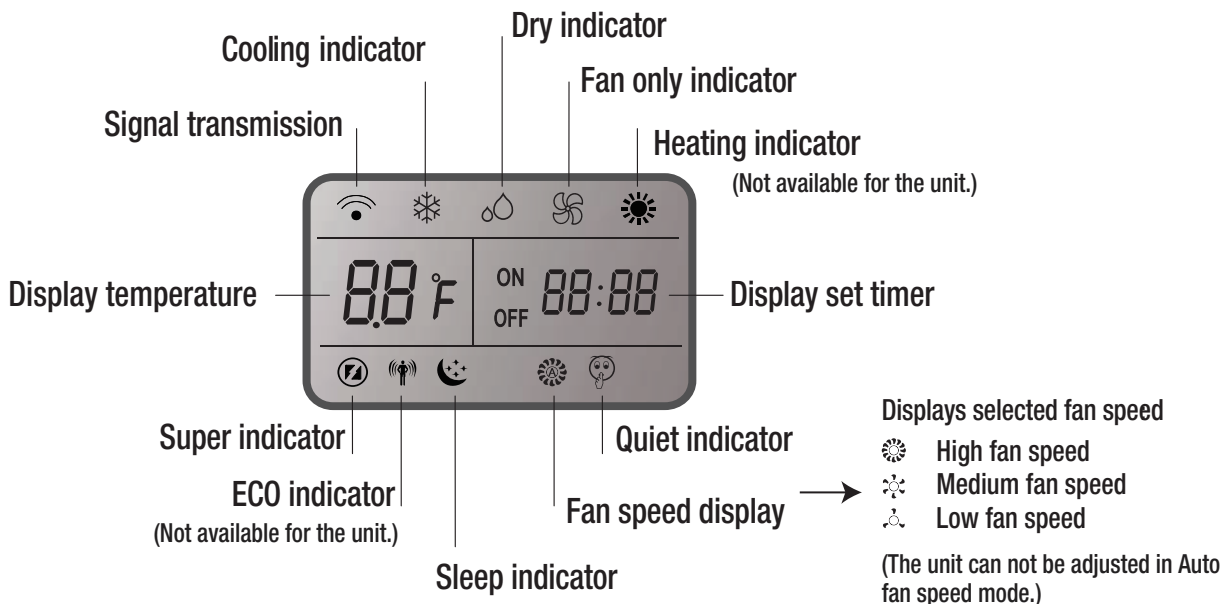

Operation (continued)



QUIET

1. Press the Quiet button to set or cancel the Quiet Mode operation.



- NOTE:**
1. It takes about 2 to 3 minutes to fully enter the quiet mode.
 2. Sometimes it cannot enter the quiet mode because of some protection.
 3. The QUIET button is disabled in dry mode.



SUPER

The SUPER button is used to start or stop fast cooling.

1. Press the SUPER button. The air conditioner automatically sets the fan speed to High and the temperature to 61 °F (16 °C).
2. To turn off Super control, press MODE, FAN, QUIET or SUPER button on the remote control.



- NOTE:**
1. In the SUPER mode, you can set the timer.
 2. SUPER button is ineffective in ECO mode.



FILTER (valid for some models)

1. When "FC" appears on the air conditioner display, please clean or replace the air filter. See "CLEANING THE AIR FILTER".
2. Press Power button on the machine or FILTER button on remote to reset the filter after cleaning and replacing the air filter.



- NOTE:** FC display will switch to normal display after 5 seconds.



DIMMER

1. Press the DIMMER button to turn off the control panel display.



- NOTE:** When in DIMMER mode, new control inputs will return display to normal.



DIMMER sleep [5 sec]

1. Press and hold the DIMMER button on the remote for 5 seconds to switch the DIMMER mode to SLEEP mode.
2. After 10 seconds, the light on the control panel display will dim.
3. To turn off Sleep control, press MODE, FAN, SLEEP or wait 8 hours for Sleep control to turn off automatically



NOTE: When you press sleep button

1. The appliance will stop operation automatically after operating for 8 hours.
2. Fan speed is automatically set at low speed.
3. In the Cooling mode, Dry mode, and ECO mode, the set temperature will increase by 4 °F (2 °C) at most, during 2 hours, and continues running at that temperature until auto shut off.
4. Sleep control cannot be selected in Fan mode.

Operation (continued)



TIMER

Use the TIMER function to turn the air conditioner ON/OFF automatically.

Setting the Air Conditioner to Turn On:

1. Plug in the air conditioner and use the remote to power it ON.
2. Use the remote to set the desired mode, temperature, fan speed, etc.
3. Use the remote to power OFF the air conditioner.
4. Press TIMER on the remote and use the UP/ DOWN buttons to set the desired delay time.
The delay time can be set from 0 to 24 hours in one-hour increments.
5. Press TIMER again to confirm the delay time. The Timer light on the unit will be on.

Setting the Air Conditioner to Turn Off:

1. Plug in the air conditioner and use the remote to power it ON.
2. Use the remote to set the desired mode, temperature, fan speed, etc.
3. Press TIMER on the remote and use the UP/ DOWN buttons to set the desired delay time.
The delay time can be set from 0 to 24 hours in one-hour increments.
4. Press TIMER again to confirm the delay time. The Timer light on the unit will be on.

To Cancel Timer:

1. Press the TIMER button again. Once a “beep” is heard and the indicator disappears, the Timer mode has been canceled.



NOTE: The TIMER function can only be set using the remote.

3 Changing Air Direction

1. Use the Vertical Vane to direct the air right or left.
2. Use the Level Vane to direct air up, down or straight ahead.

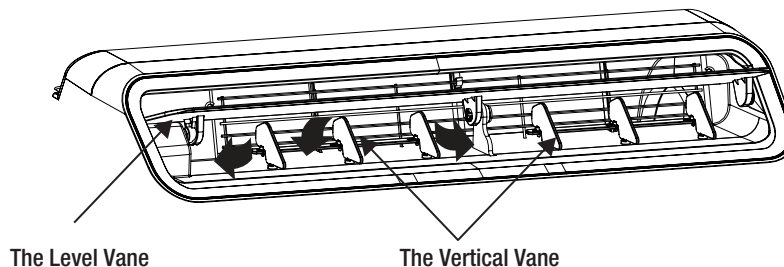

4 Normal Sounds

When your air conditioner is operating normally, you may hear sounds such as:

1. Droplets of water hitting the condenser, causing a pinging or clicking sound. The water droplets help cool the condenser.
2. Air movement from the fan.
3. Clicks from the thermostat cycle.
4. A high-pitched hum or pulsating noise caused by the modern high-efficiency compressor cycling on and off.

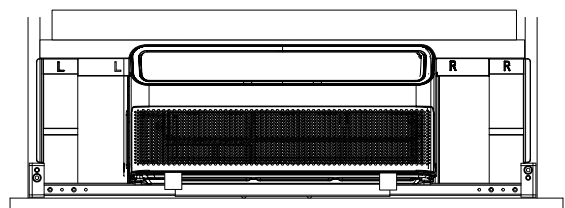

Care and Cleaning

Your new air conditioner is designed to give you many years of dependable service. This section tells you how to clean and care for your air conditioner properly. Call your local authorized dealer for an annual checkup. Remember the cost of this service call is your responsibility.

CLEANING THE AIR FILTER

The air filter is removable for easy cleaning. A clean filter helps remove dust, lint, and other particles from the air and is important for best cooling and operating efficiency. Check the filter every 2 weeks to see whether it needs cleaning.



NOTE: 1. Do not operate the air conditioner without the filter in place.
2. Do not touch the metal parts of the unit, when the air filter is to be removed. It may cause injury.

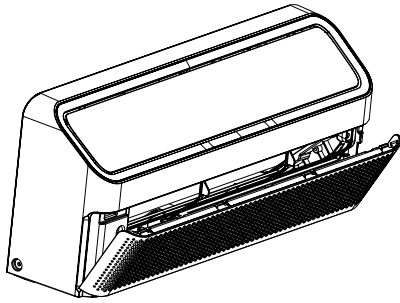

1. Turn off the air conditioner.
2. Open the front panel. Grasp the filter by the handle and pull it out.

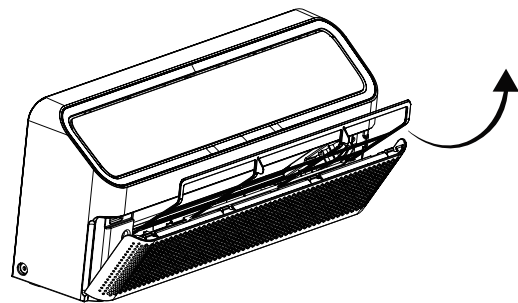

3. Use a vacuum cleaner to clean the air filter. If the air filter is very dirty, wash it in warm water with a mild detergent. Do not wash the air filter in the dishwasher or use any chemical cleaners. Air dry the filter completely before replacing to ensure maximum efficiency.
4. Replace the air filter back into the air conditioner.

CLEANING THE FRONT PANEL

1. Turn off the air conditioner.
2. Clean the front panel with a soft, damp cloth.
3. Air dry the front panel completely.



ANNUAL MAINTENANCE

Your air conditioner needs annual maintenance to help ensure steady, top performance throughout the year. Call your local authorized dealer to schedule an annual checkup. The expense of an annual inspection is your responsibility.

REMOVING AC FROM WINDOW

1. Turn AC off, and disconnect power cord.
2. Remove the EVA foam.
3. Remove sash seal from between windows and unscrew safety lock.
4. Remove screws installed through frame and frame lock.
5. Close the curtain housing.
6. Keeping a firm grip on air conditioner, raise sash and carefully remove.
7. Be careful not to spill any standing water while lifting unit from window.
8. Remove the support bracket.
9. Store parts with the AC.

Troubleshooting

Problem	Solution
<p>Air conditioner will not operate</p>	<p>DANGER: ELECTRICAL SHOCK HAZARD</p>  <ol style="list-style-type: none"> 1. Plug into a grounded 3-prong outlet. 2. Do not remove ground prong. 3. Do not use an adapter. 4. Do not use an extension cord. 5. Failure to follow these instructions can result in death, fire, or electrical shock. <ol style="list-style-type: none"> 1. The power supply cord is unplugged. Plug into grounded 3-prong outlet. See “ELECTRICAL REQUIREMENTS”. 2. The power supply cord has tripped (RESET button has popped out). Press and release RESET to resume operation. 3. A household fuse has blown, or circuit breaker has tripped. Replace the fuse or reset the circuit breaker. If the problem continues, call an electrician. See “ELECTRICAL REQUIREMENTS”. 4. The Power button has not been pressed. Press the Power button. 5. The local power has failed. Wait for power to be restored.
<p>Air conditioner blows fuses or trips circuit breakers</p>	<ol style="list-style-type: none"> 1. Too many appliances are being used on the same circuit. Unplug or relocate appliances that share the same circuit. 2. Time-delay fuse or circuit breaker of the wrong capacity is being used. Replace with a time-delay fuse or circuit breaker of the correct capacity. See “ELECTRICAL REQUIREMENTS”. 3. An extension cord is being used. Do not use an extension cord with this or any other appliance. 4. You are trying to restart the air conditioner too soon after turning off the air conditioner. Wait at least 3 minutes after turning off the air conditioner before trying to restart the air conditioner.
<p>Air conditioner power supply cord trips (Reset button pops out)</p>	<ol style="list-style-type: none"> 1. Disturbances in your electrical current can trip (RESET button will pop out) the power supply cord. Press and release RESET to resume operation. 2. Electrical overloading, overheating, cord pinching or aging can trip (RESET button will pop out) the power supply cord. After correcting the problem, press and release RESET to resume operation. <p> NOTE: A damaged power supply cord must be replaced with a new power supply cord obtained from the product manufacturer and must not be repaired.</p>

Troubleshooting

Problem	Solution
<p>Air conditioner seems to run too much</p>	<ol style="list-style-type: none"> 1. The current air conditioner replaced an older model. The use of more efficient components may cause the air conditioner to run longer than an older model, but the total energy consumption will be less. Newer air conditioners do not emit the “blast” of cold air you may be accustomed to from older air conditioners, but this is not an indication of lesser cooling capacity or efficiency. Refer to the efficiency rating (EER) and capacity rating (in Btu/h) marked on the air conditioner. 2. The air conditioner is in a heavily occupied room, or heat producing appliances are in use in the room. Use exhaust vent fans while cooking or bathing and try not to use heat producing appliances during the hottest part of the day. A higher capacity air conditioner may be required, depending on the size of the room being cooled.
<p>Air conditioner cycles on and off too much or does not cool</p>	<ol style="list-style-type: none"> 1. The air conditioner is not properly sized for your room. Check the cooling capabilities of your room air conditioner. Room air conditioners are not designed to cool multiple rooms. 2. The filter is dirty or obstructed by debris. Clean the filter. 3. The inside evaporator and outside condenser coils are dirty or obstructed by debris. See “ANNUAL MAINTENANCE”. 4. There is excessive heat or moisture (open container cooking, showers, etc.) in the room. Use a fan to exhaust heat or moisture from the room. Try not to use heat producing appliances during the hottest part of the day. 5. The louvers are blocked. Install the air conditioner in a location where the louvers are free from curtains, blinds, furniture, etc. 6. The temperature of the room you are trying to cool is extremely hot. Allow extra time for the air conditioner to cool off a very hot room. 7. Windows or doors to the outside are open. Close all windows and doors. 8. The Temp control is not at a cool enough setting. Adjust the Temp control to a cooler setting by pressing the minus button to reduce the temperature. Set the Fan Speed control to the highest setting.
<p>Water drips from cabinet into your house</p>	<p>1. The air conditioner is not properly leveled. The air conditioner should slope slightly downward toward the outside. Level the air conditioner to provide a downward slope toward the outside to ensure proper drainage. See the Installation Instructions.</p> <div style="background-color: #e0e0e0; padding: 10px; margin-top: 10px;">  <p>NOTE: Do not drill a hole in the bottom of the metal base and condensate pan.</p> </div>

