

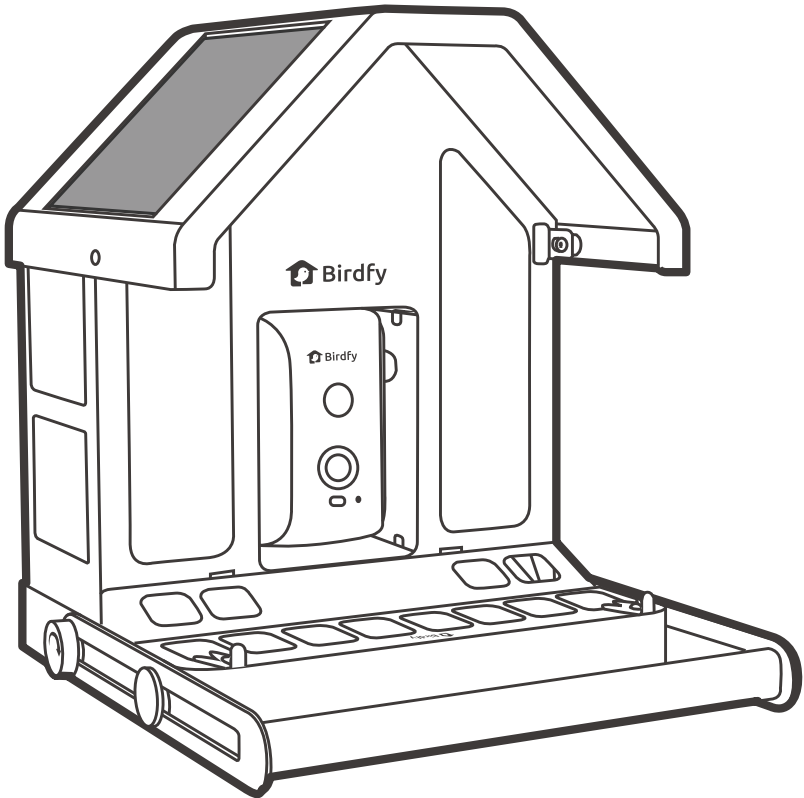

Birdfy

# User Manual

Birdfy Feeder Metal



EN

ES

FR

# Catalog

What's in the Box .....	1-3
About the Product .....	4-6
Charging .....	7-8
Downloading the Birdfy App .....	9-11
Assembly .....	12
Outdoor Installation .....	13-19
Adding Birdseed .....	20-21
Adjusting the Perch .....	22
Cleaning .....	23
Support .....	24-27
The Birdfy Community .....	28
Warning .....	29-32

# Catálogo

Contenido del paquete .....	1-3
Acerca del producto .....	4-6
Carga .....	7-8
Descarga de la aplicación Birdfy .....	9-11
Ensamblaje .....	12
Instalación al aire libre .....	13-19
Añadir comida para pájaros .....	20-21
Ajuste del posadero .....	22
Limpieza .....	23
Apoyo .....	24-27
La comunidad Birdfy .....	28
Advertencia .....	29-32

# Catalogue

Contenu de la boîte .....	1-3
À propos du produit .....	4-6
Chargement .....	7-8
Téléchargement de l'application Birdfy .....	9-11
Assemblage .....	12
Installation extérieure .....	13-19
Ajout de graines pour oiseaux .....	20-21
Réglage du perchoir .....	22
Nettoyage .....	23
Soutien .....	24-27
La communauté Birdfy .....	28
Avertissement .....	29-32

# What's in the Box

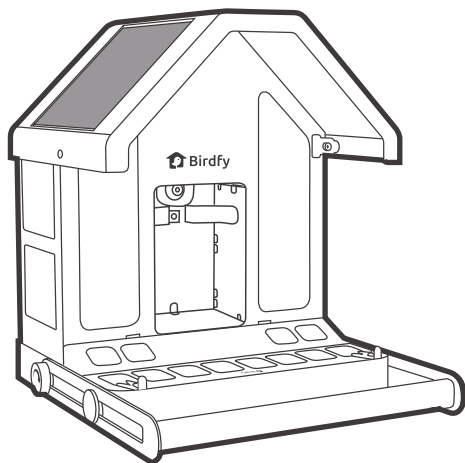

Feeder  
Alimentador  
Mangeoire

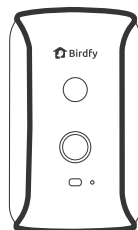

Camera  
Cámara  
Caméra



User Manual  
Manual del usuario  
Manuel d'utilisation



Quick Start Guide  
Guía de inicio rápido  
Guide de démarrage rapide



Installation package  
Paquete de instalación  
Pack d'installation

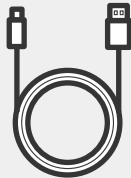

Charging cable  
Cable de carga  
Câble de chargement



Hose clips  
Clips para manguera  
Clips de tuyau

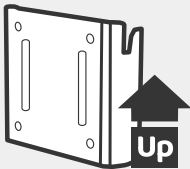

Hanging bracket  
Soporte colgante  
Support de suspension

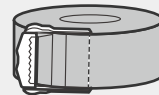

Black strap  
Correa negra  
Sangle noire

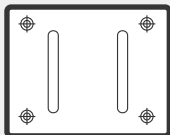

Drilling template  
Plantilla de perforación  
Gabarit de perçage

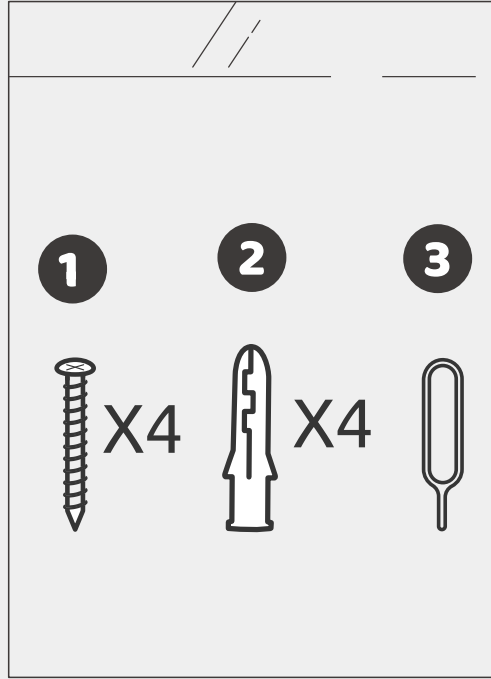

**1** Screws  
Tornillos  
Vis

**2** Anchors  
Anclajes  
Chevilles

**3** Ejector pin  
Pasador expulsor  
Goupille d'éjection

# About the Product

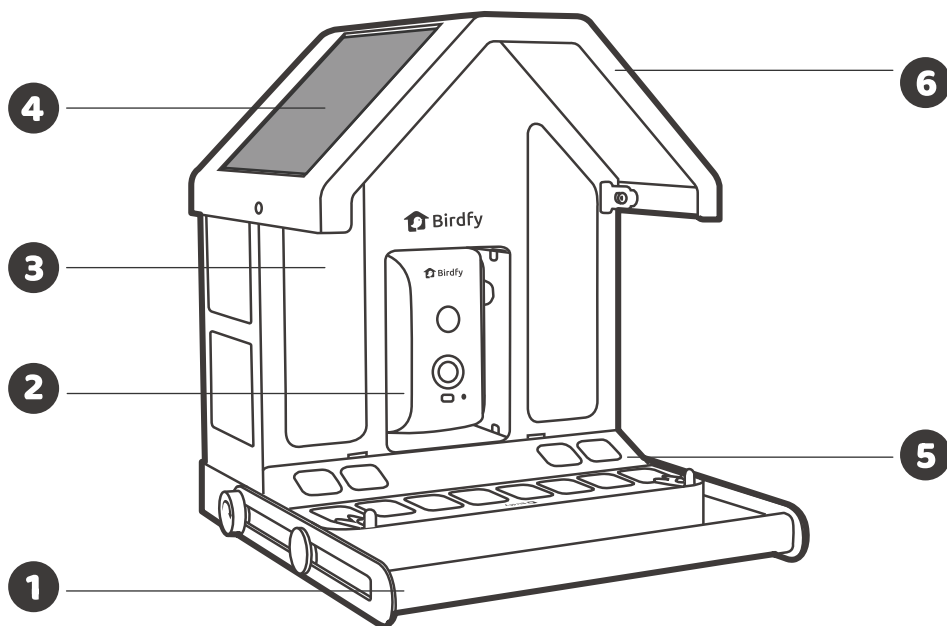

**1** Perch  
Percha  
Perchoir

**2** Camera  
Cámara  
Caméra

**3** Acrylic panel  
Panel acrílico  
Panneau en acrylique

**4** Solar panel  
Panel solar  
Panneau solaire

**5** Seed guard  
Protector de semillas  
Garde-graines

**6** Roof  
Techo  
Toit

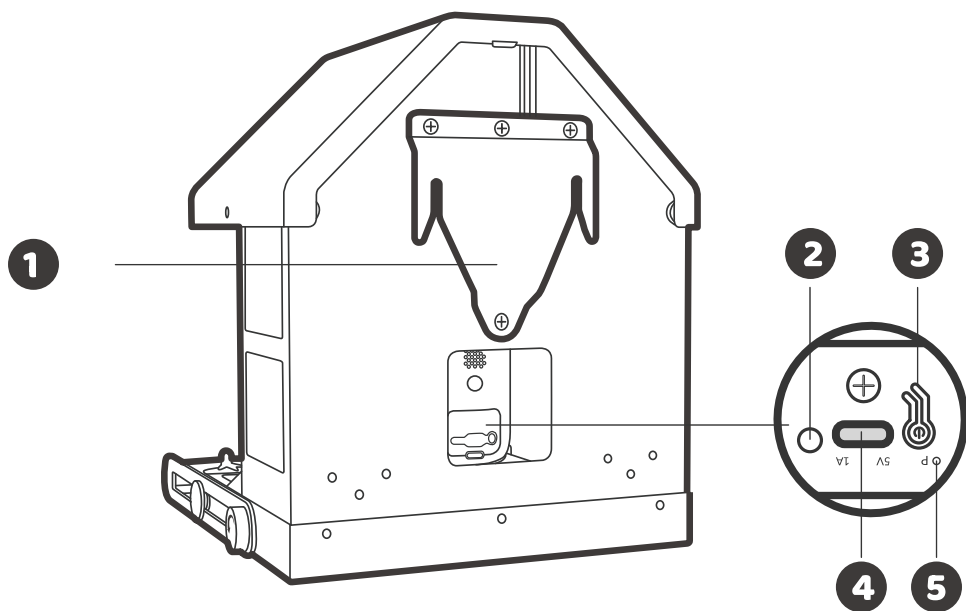

**1** Mounting bracket  
Soporte de montaje  
Soporte de montage

**2** Status light  
Luz de estado  
Le voyant d'état

**3** Power button  
Botón de encendido  
Bouton d'alimentation

**4** Charging port  
Puerto de carga  
Port de charge

**5** Reset hole  
Agujero de reinicio  
Trou de réinitialisation



\*Please note that the microSD card slot on the camera is intended only for manufacturer testing during production. This product does not support microSD card storage.

\*Por favor, ten en cuenta que la ranura para tarjeta microSD en la cámara está destinada únicamente para pruebas de fabricante durante la producción. Este producto no admite almacenamiento en tarjetas microSD.

\*Veuillez noter que le slot de carte microSD sur l'appareil photo est réservé uniquement aux tests du fabricant pendant la production. Ce produit ne prend pas en charge le stockage sur carte microSD.

# Charging

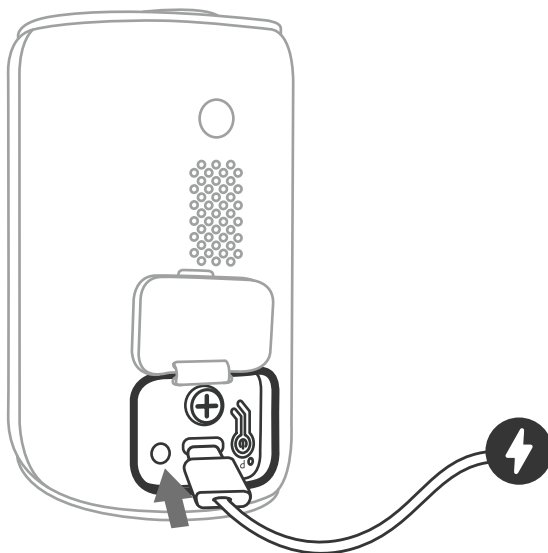

## Fully charge the camera before use

The camera does not come fully charged due to safety regulations. Before using it for the first time, please charge it for 14 hours with the charging cable inside the box (DC5V / 1A).

## Cargue completamente la cámara antes de usarla

La cámara no viene completamente cargada debido a regulaciones de seguridad. Antes de usarla por primera vez, por favor cárguela durante 14 horas con el cable de carga que se encuentra en la caja (DC5V / 1A).

## Chargez complètement la caméra avant utilisation

La caméra n'est pas complètement chargée en raison des réglementations de sécurité. Avant de l'utiliser pour la première fois, veuillez la charger pendant 14 heures avec le câble de chargement fourni dans la boîte (DC5V / 1A).

<b>Status Light</b> <b>Luz de estado</b> <b>Le voyant d'état</b>	<b>Description</b> <b>Descripción</b> <b>Description</b>
Solid red Rojo fijo Rouge fixe	Charging Cargando En charge
Off Apagado Éteint	Fully charged Completamente cargado Complètement chargé
Solid blue Azul fijo Bleu solide	Working Laborable En fonctionnement
Flashing blue Azul intermitente Bleu clignotant	Wi-Fi Config Mode Modo de configuración de Wi-Fi Mode de configuration Wi-Fi



When charging, both the ambient temperature and camera temperature should be above 32°F (0°C).

If the camera has been exposed to low temperatures for an extended period, it should be brought back to room temperature before charging.

Durante la carga, tanto la temperatura ambiente como la temperatura de la cámara deben estar por encima de los 32°F (0°C). Si la cámara ha estado expuesta a bajas temperaturas durante un período prolongado, debe ser llevada a temperatura ambiente antes de cargarla.

Lors de la charge, la température ambiante ainsi que la température de la caméra doivent être supérieures à 32°F (0°C). Si la caméra a été exposée à de basses températures pendant une période prolongée, elle doit être ramenée à température ambiante avant d'être chargée.

# Downloading the Birdfy App



Follow the in-app instructions to set up your Birdfy.

Sigue las instrucciones dentro de la aplicación para configurar tu Birdfy.

Suivez les instructions dans l'application pour configurer votre Birdfy.

Pair your Birdfy device with the app.

Vincula tu dispositivo Birdfy con la aplicación.

Associez votre appareil Birdfy avec l'application.

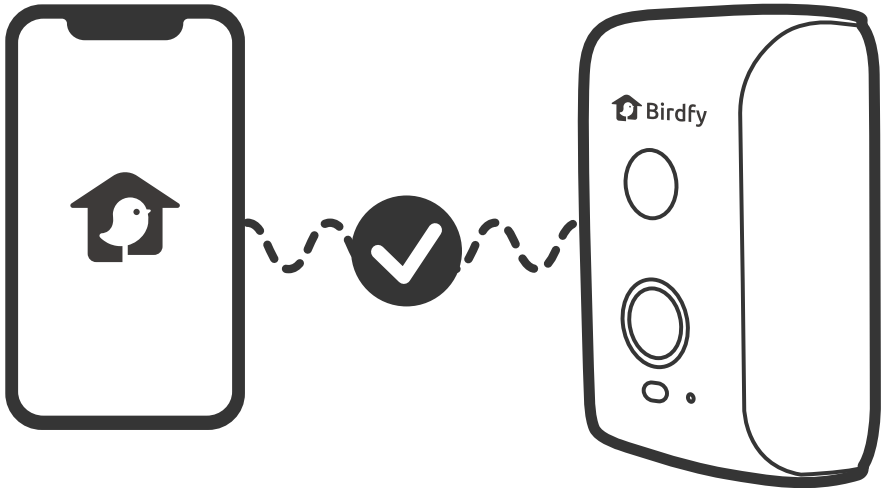

## Bird Identification

- If you have the Birdfy Feeder Metal with Lifetime Free AI, the AI bird identification feature is included and activated automatically, no further action needed.
- If you have the Birdfy Feeder Metal with AI by Subscription, you need to subscribe on **my.birdfy.com** to access this feature.

## Identificación de aves

- Si tienes el Birdfy Feeder Metal con IA gratuita de por vida, la función de identificación de aves mediante IA está incluida y se activa automáticamente, no se requiere ninguna acción adicional.
- Si tienes el Birdfy Feeder Metal con AI por suscripción, debes suscribirte en **my.birdfy.com** para acceder a esta función.

## Identification des oiseaux

- Si vous avez le Birdfy Feeder Metal avec l'IA gratuite à vie, la fonction d'identification des oiseaux par IA est incluse et activée automatiquement, aucune action supplémentaire n'est nécessaire.
- Si vous possédez le Birdfy Feeder Metal avec l'IA par abonnement, vous devez vous abonner sur **my.birdfy.com** pour accéder à cette fonctionnalité.

# Assembly

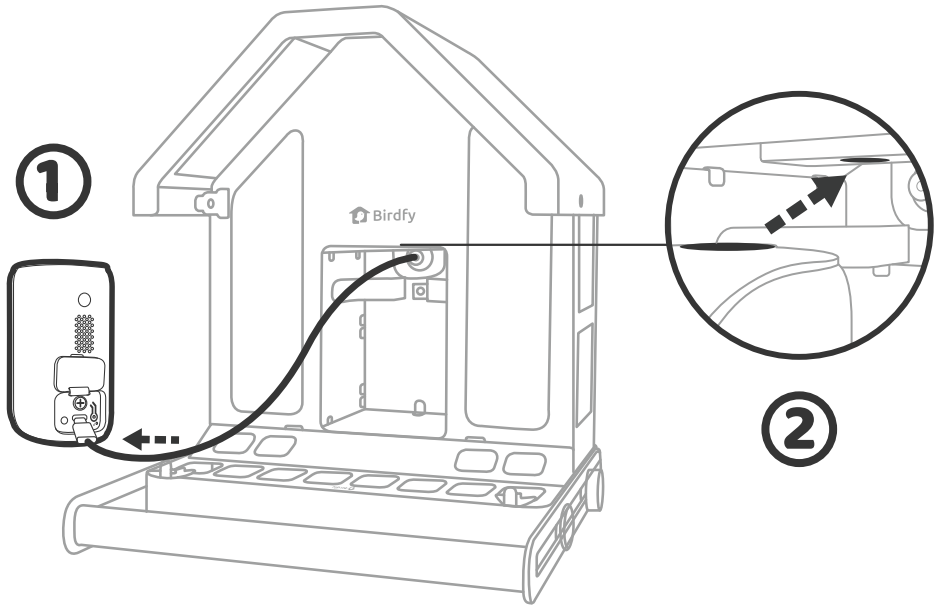

1. Connect the camera to the solar panel, then put it into the camera compartment.

1. Conecte la cámara al panel solar, luego colóquela en el compartimento de la cámara.

1. Connectez la caméra au panneau solaire, puis placez-la dans le compartiment de la caméra.

2. Make sure the camera is properly aligned with the magnetic connector and securely attached.

2. Asegúrese de que la cámara esté correctamente alineada con el conector magnético y bien sujeta.

2. Assurez-vous que la caméra est correctement alignée avec le connecteur magnétique et solidement fixée.

# Outdoor Installation

## A. Pole-mounted



or

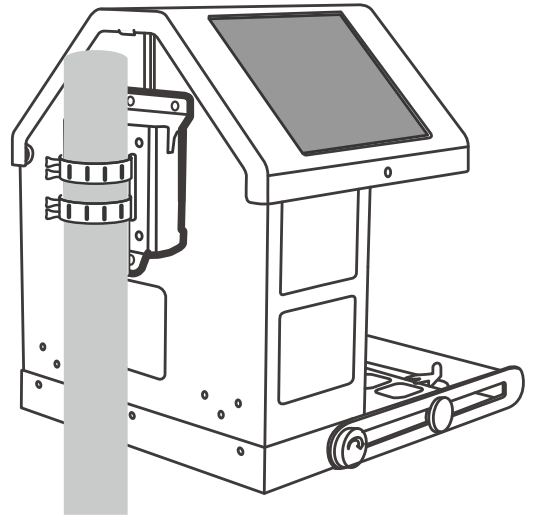
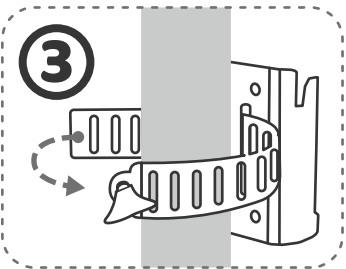
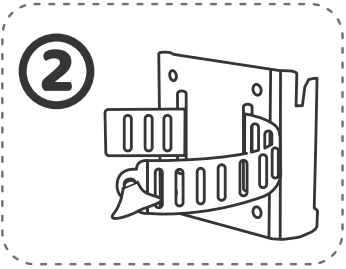
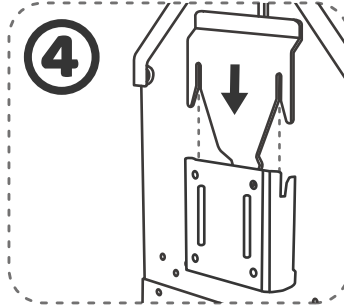
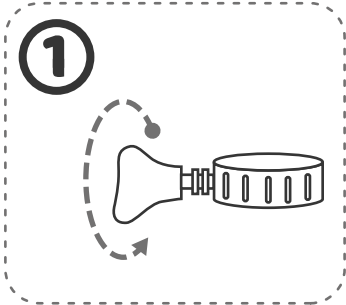
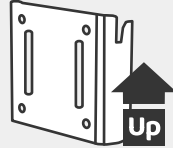

1. Loosen the hose clip.  
1. Afloje la abrazadera de la manguera.  
1. Desserrer le collier de serrage pour tuyau.
  
2. Wrap the hose clip around the hanging bracket.  
2. Envuelva la abrazadera de la manguera alrededor del soporte de suspensión.  
2. Enrouler le collier de serrage autour du support de suspension.
  
3. Attach the hanging bracket to the pole.  
3. Coloque el soporte de suspensión en el poste.  
3. Fixer le support de suspension sur le poteau.
  
4. Hang the feeder on the pole.  
4. Cuelgue el comedero en el poste.  
4. Accrocher le distributeur sur le poteau.

## B. Tree-mounted

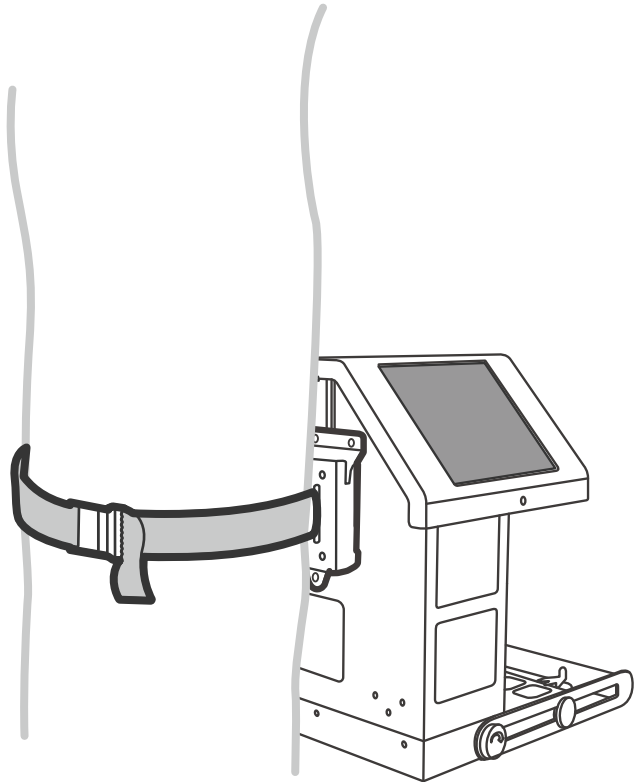
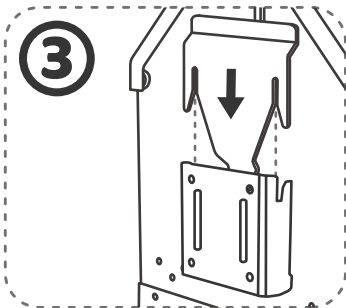
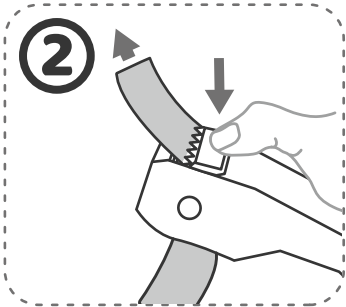
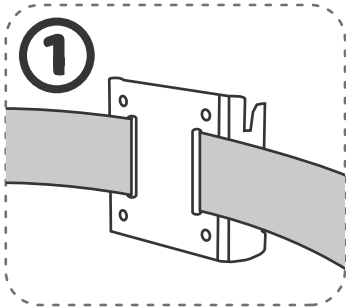
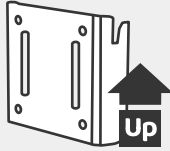
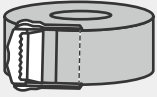

1. Slide the strap through the hanging bracket slots.  
1. Desliza la correa a través de las ranuras del soporte de suspensión.  
1. Faites glisser la sangle à travers les fentes du support de suspension.
2. Wrap the strap around the tree.  
2. Envuelva la correa alrededor del árbol.  
2. Enroulez la sangle autour de l'arbre.
3. Hang the feeder on the tree.  
3. Cuelgue el comedero en el árbol.  
3. Accrochez le distributeur sur l'arbre.

# C. Wall-mounted

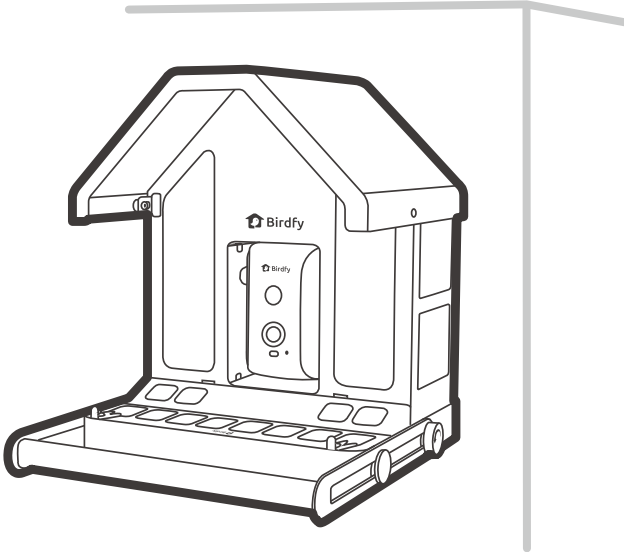
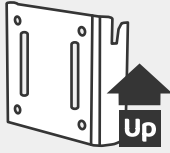
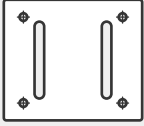

1

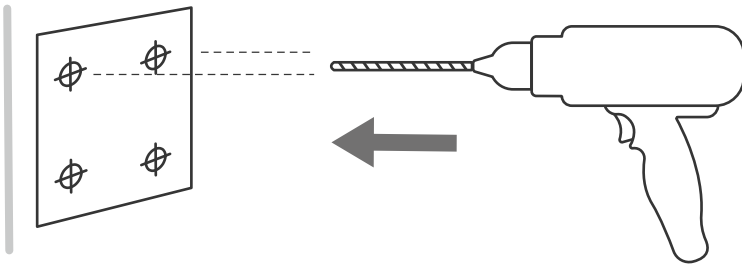

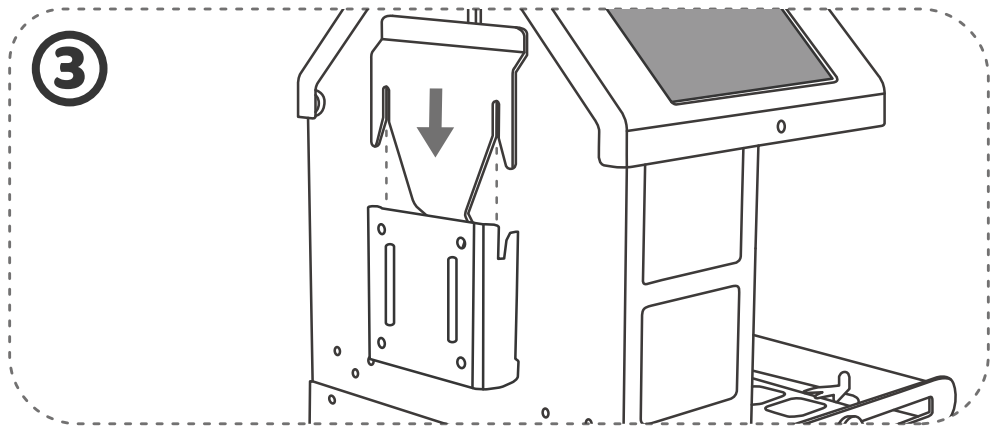
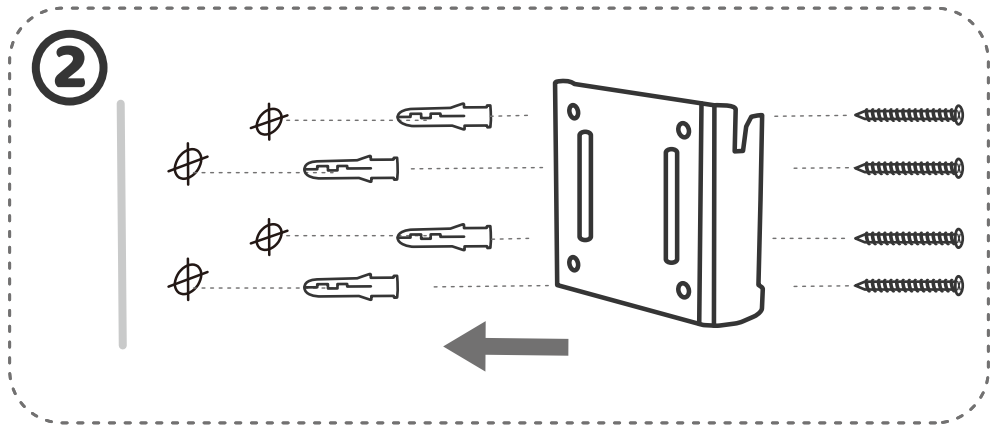

1. Use the drill template and an electric drill (15/64", 6mm) to drill four holes.

1. Utiliza la plantilla de perforación y un taladro eléctrico (15/64", 6mm) para perforar cuatro agujeros.

1. Utilisez le gabarit de perçage et une perceuse électrique (15/64", 6 mm) pour percer quatre trous.

2. Drive the provided plastic anchors into the holes. Skip this step if you are mounting on wood. Next, fasten the hanging bracket on the wall using the screws.

2. Inserta los anclajes de plástico provistos en los agujeros. Omite este paso si vas a montar en madera. A continuación, fija el soporte de suspensión en la pared utilizando los tornillos.

2. Insérez les chevilles en plastique fournies dans les trous. Passez cette étape si vous montez sur du bois. Ensuite, fixez le support de suspension sur le mur à l'aide des vis.

3. Hang the feeder on the wall.

3. Cuelga el comedero en la pared.

3. Accrochez le mangeoire sur le mur.

# Adding Birdseed

①

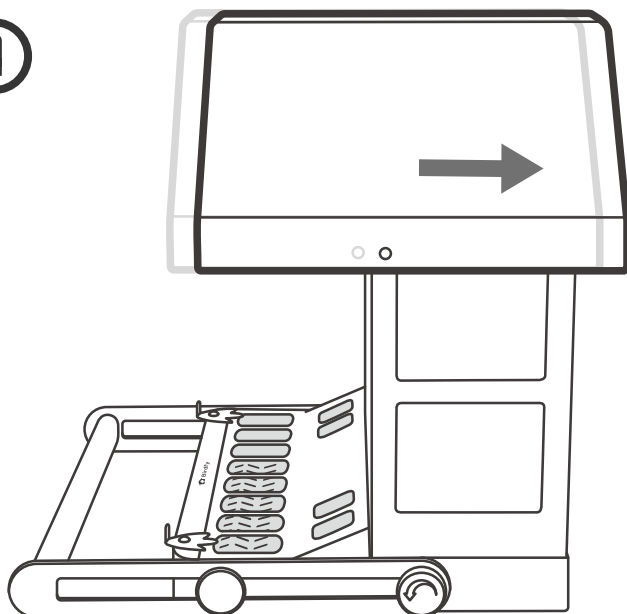

1. Push the roof backward to disengage the magnet and unlock it.

1. Empuje el techo hacia atrás para desenganchar el imán y desbloquearlo.

1. Poussez le toit vers l'arrière pour désengager l'aimant et le déverrouiller.

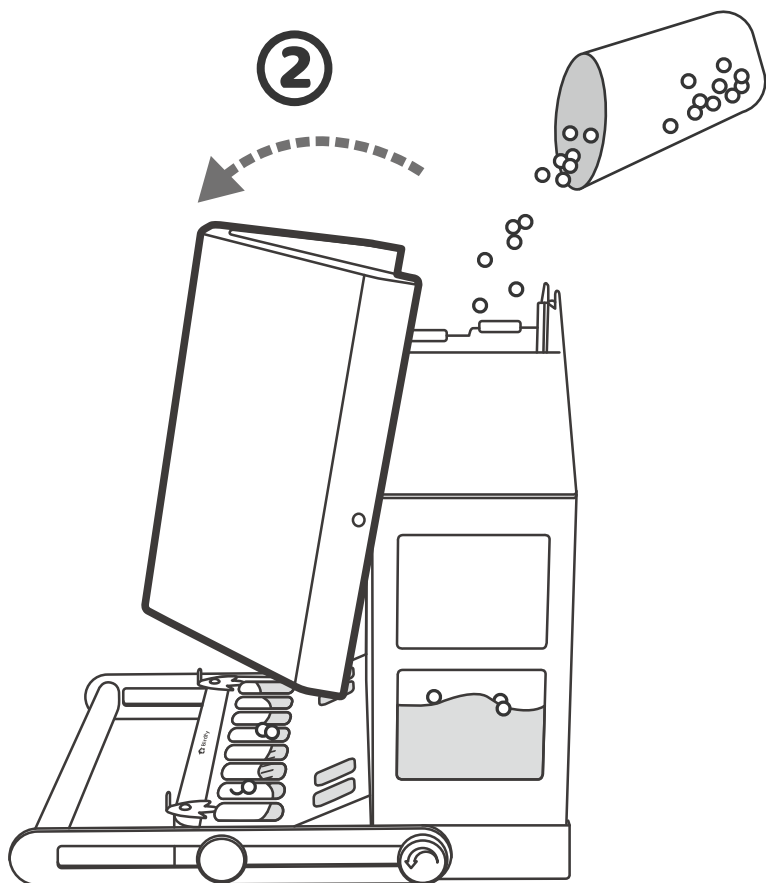

2. Open the roof to add birdseed.

2. Abra el techo para agregar semillas para pájaros.

2. Ouvrez le toit pour ajouter des graines pour oiseaux.

3. Close the roof and pull it forward to secure the magnet.

3. Cierre el techo y tire de él hacia adelante para asegurar el imán.

3. Fermez le toit et tirez-le vers l'avant pour sécuriser l'aimant.

# Adjusting the Perch

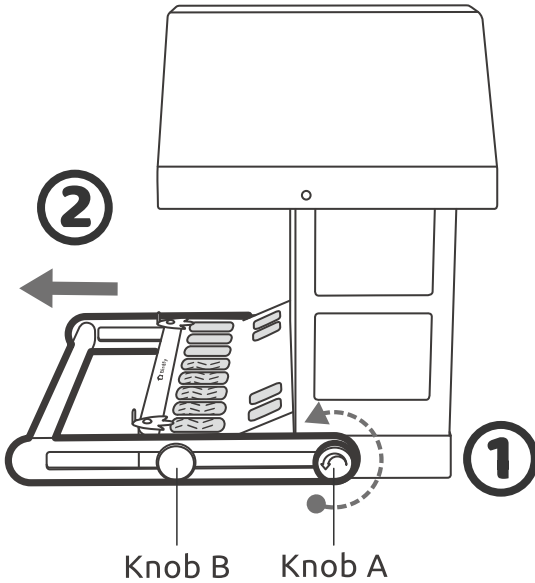

1. Turn Knob A counterclockwise to loosen it.
  1. Gire la perilla A en sentido antihorario para aflojarla.
  1. Tournez le bouton A dans le sens antihoraire pour le desserrer.
  2. Adjust the perch to the desired length.
  2. Ajuste el posadero a la longitud deseada.
  2. Réglez le perchoir à la longueur souhaitée.
  3. Turn Knob A clockwise to tighten it.
  3. Gire la perilla A en sentido horario para apretarla.
  3. Tournez le bouton A dans le sens horaire pour le serrer.
- \*Knob B is not adjustable; there is no need to turn it.  
\*La perilla B no es ajustable; no es necesario girarla.  
\*Le bouton B n'est pas réglable ; il n'est pas nécessaire de le tourner.

# Cleaning

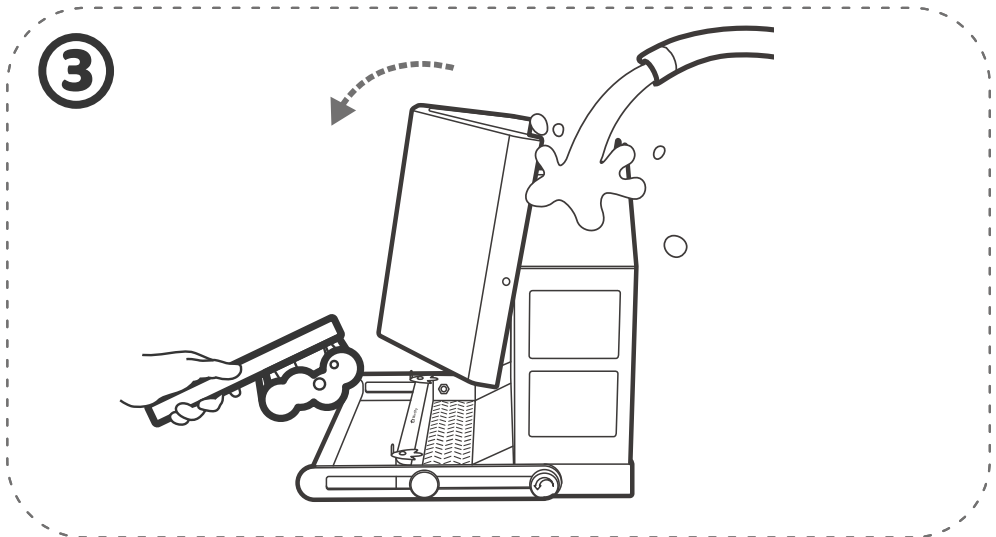
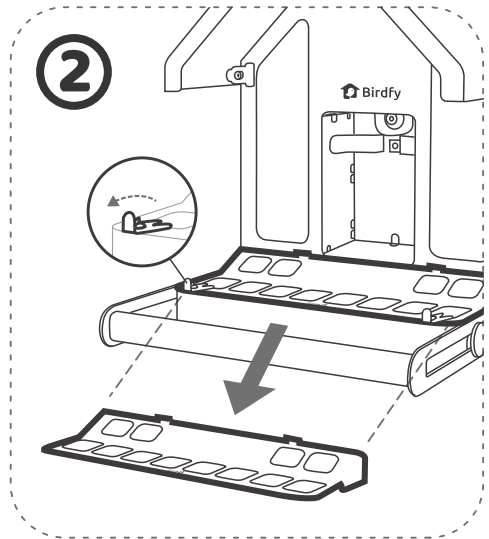
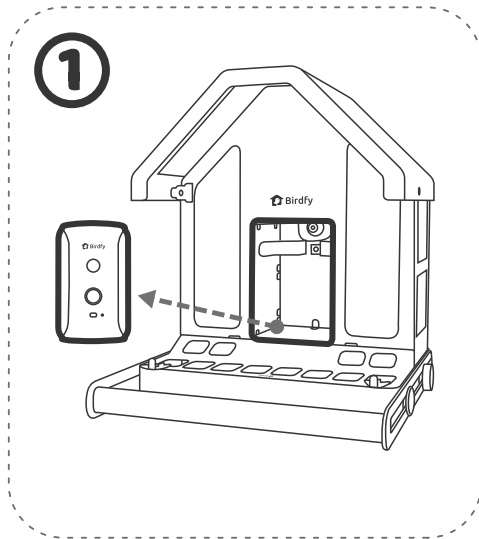

\* Please note that bleach should not be used.

\* Ten en cuenta que no se debe usar lejía.

\* Veuillez noter qu'il ne faut pas utiliser d'eau de Javel.

# Support



Birdfy Help Center



We are dedicated to offering top-notch products and services to our customers. Should you encounter any issues with your Birdfy, please don't hesitate to reach out to us.

- Email: [support@birdfy.com](mailto:support@birdfy.com)
- Phone: 1(866)749-0567 (Mon - Fri, 9am-5pm, PST)
- In-App Live Chat

If your Birdfy camera goes offline or fails to stream, try these troubleshooting steps:

1. Ensure the camera is fully charged.
2. Verify your home Wi-Fi connectivity. Try to reconnect the camera to your Wi-Fi network.

Nos dedicamos a ofrecer productos y servicios de primera calidad a nuestros clientes. Si tiene algún problema con su Birdfy, no dude en contactarnos.

- Correo electrónico: [support@birdfy.com](mailto:support@birdfy.com)
- Teléfono: 1(866)749-0567 (lun - vie, 9am-5pm, PST)
- Chat en vivo en la aplicación

Si tu cámara Birdfy se desconecta o no puede transmitir, prueba estos pasos de resolución de problemas:

1. Asegúrate de que la cámara esté completamente cargada.
2. Verifica la conectividad de tu red Wi-Fi doméstica. Intenta reconectar la cámara a tu red Wi-Fi.

Nous nous engageons à offrir des produits et services de qualité supérieure à nos clients. Si vous rencontrez des problèmes avec votre Birdfy, n'hésitez pas à nous contacter.

- E-mail : [support@birdfy.com](mailto:support@birdfy.com)

- Téléphone : 1(866)749-0567 (lun - ven, 9h-17h, PST)

- Chat en direct dans l'application

Si votre caméra Birdfy se déconnecte ou ne parvient pas à diffuser, suivez ces étapes de dépannage :

1. Assurez-vous que la caméra est complètement chargée.
2. Vérifiez la connectivité de votre réseau Wi-Fi domestique. Essayez de reconnecter la caméra à votre réseau Wi-Fi.

**If the issue persists:**

1. Disconnect the camera from the solar panel or charger.
2. Use the provided ejector pin or a paperclip to press the reboot hole to power down the camera entirely.
3. Press and hold the power button for 3 seconds to restart the camera.

**Si el problema persiste:**

1. Desconecta la cámara del panel solar o del cargador.
2. Usa el pasador de expulsión proporcionado o un clip de papel para presionar el orificio de reinicio y apagar completamente la cámara.
3. Mantén presionado el botón de encendido durante 3 segundos para reiniciar la cámara.

**Si le problème persiste :**

1. Débranchez la caméra du panneau solaire ou du chargeur.
2. Utilisez le poinçon d'éjection fourni ou un trombone pour appuyer sur le trou de réinitialisation et éteindre complètement la caméra.
3. Maintenez le bouton d'alimentation enfoncé pendant 3 secondes pour redémarrer la caméra.

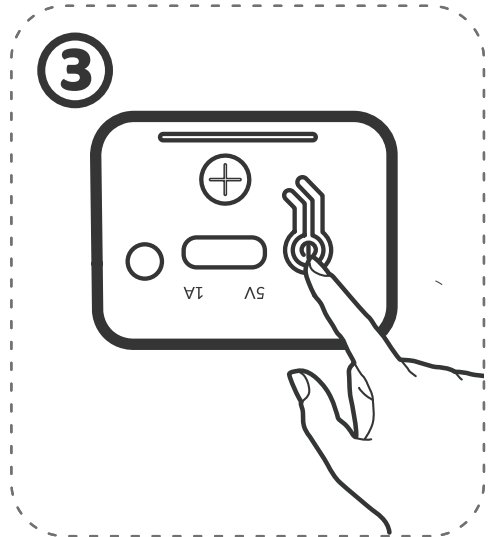
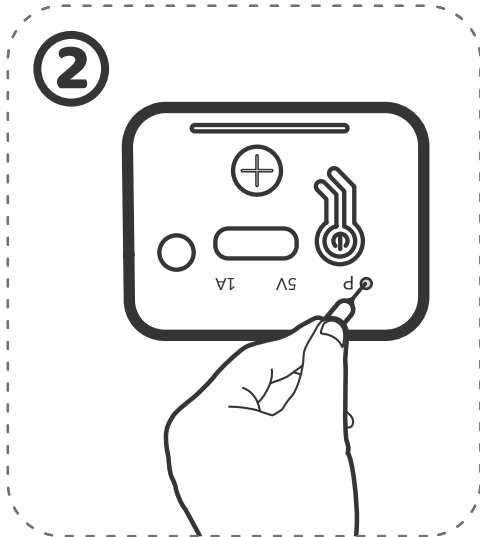
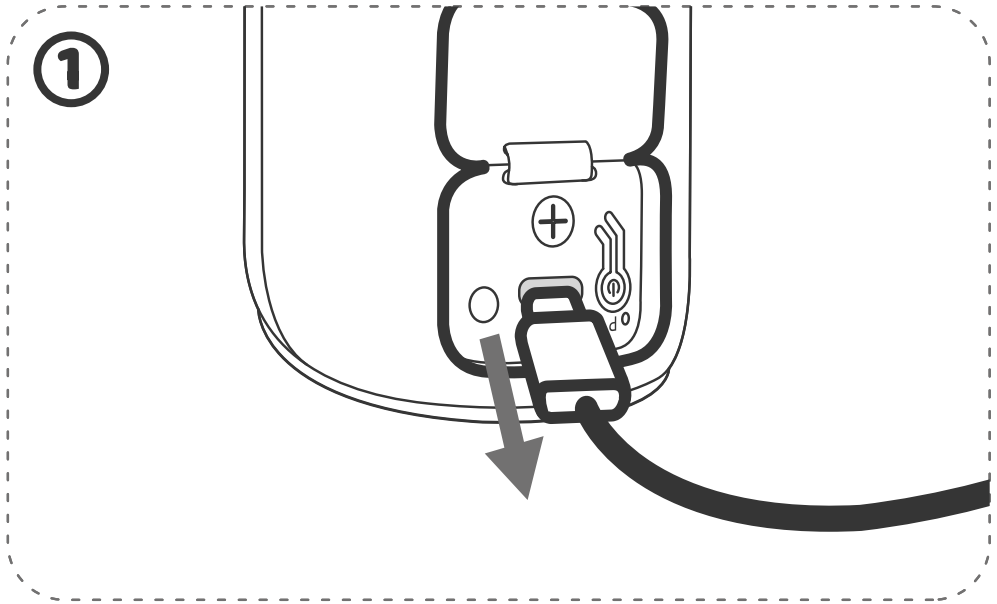

# The Birdfy Community

Scan the QR code to join our vibrant Facebook community and connect with fellow bird enthusiasts! Discover valuable insights on birdwatching and bird feeding techniques, exchange your finest Birdfy captures, and witness exotic birds from around the world!

Escanee el código QR para unirse a nuestra vibrante comunidad de Facebook y conectarse con otros entusiastas de las aves. Descubra información valiosa sobre observación de aves y técnicas de alimentación, intercambie sus mejores capturas de Birdfy y observe aves exóticas de todo el mundo.

Scannez le code QR pour rejoindre notre communauté Facebook dynamique et vous connecter avec d'autres passionnés d'oiseaux ! Découvrez des informations précieuses sur l'observation des oiseaux et les techniques d'alimentation, partagez vos meilleures captures Birdfy et contemplez des oiseaux exotiques du monde entier !



Birdfy FB Community

Join our community!



@birdfy by netvue

# Warning

Note: This equipment has been tested and found to comply with the limits for a Class B digital device, pursuant to part 15 of the FCC Rules. These limits are designed to provide reasonable protection against harmful interference in a residential installation. This equipment generates, uses and can radiate radio frequency energy and, if not installed and used in accordance with the instructions, may cause harmful interference to radio communications. However, there is no guarantee that interference will not occur in a particular installation. If this equipment does cause harmful interference to radio or television reception, which can be determined by turning the equipment off and on, the user is encouraged to try to correct the interference by one or more of the following measures:

- Reorient or relocate the receiving antenna.
- Increase the separation between the equipment and receiver.
- Connect the equipment into an outlet on a circuit different from that to which the receiver is connected.
- Consult the dealer or an experienced radio/TV technician for help.

This device complies with part 15 of the FCC Rules. Operation is subject to the following two conditions: (1) This device may not cause harmful interference, and (2) this device must accept any interference received, including interference that may cause undesired operation.

Any changes or modifications made without explicit approval from the responsible party in compliance may result in the user being unauthorized to operate the device.

This device meets the FCC radiation exposure limits for uncontrolled environments. To ensure safe installation and operation, maintain a minimum distance of 20cm between the radiator and your body.

FCC ID: 2BC96NI-8171

### **CE Statement**

The information provided on the packaging is allowed to identify geographical areas within the member states where restrictions on use or requirements for authorized use exist, if applicable. The structure of the product allows it to be used in at least one member state without violating applicable requirements for the use of radio spectrum.

NETVUE INC.

1055 East Colorado Boulevard 5th Floor  
Pasadena, CA, 91106

### **IC Statement**

This device contains licence-exempt transmitter(s)/receiver(s) that comply with Innovation, Science and Economic Development Canada's licence-exempt RSS(s). Operation is subject to the following two Economic Development Canada's licence-exempt RSS(s). Operation is subject to the following two conditions:

1. This device may not cause interference.
2. This device must accept any interference, including interference that may cause undesired operation of the device.

This device contains licence-exempt transmitter(s)/receiver(s) that comply with Innovation, Science and Economic Develop-

ment Canada's licence-exempt RSS(s). Operation is subject to the following two Economic Development Canada's licence-exempt RSS(s). Operation is subject to the following two conditions:

1. This device may not cause interference.
2. This device must accept any interference, including interference that may cause undesired operation of the device.

This equipment complies with IC radiation exposure limits set forth for an uncontrolled environment. This transmitter must not be co-located or operating in conjunction with any other antenna or transmitter. This equipment should be installed and operated with a minimum distance of 20cm between the radiator and your body.

Cet équipement respecte les limites d'exposition au rayonnement IC établies pour un environnement non contrôlé. Cet émetteur ne doit pas être localisé ou fonctionner en conjonction avec une autre antenne ou un autre émetteur. Cet équipement doit être installé et utilisé à une distance minimale de 20cm entre le radiateur et votre corps.

Manufacturer: NETVUE INC.

1055 East Colorado Boulevard 5th Floor, Pasadena, CA, 91106  
+1 (866) 749-0567 support@birdfy.com

Made in China

Designed in USA

Model: NI-8171/NI-8172



Icamera International Trading Co., Ltd  
Unit G25 Waterfront Studios  
1 Dock Road, London, United Kingdom  
support@birdfy.com



eVatmaster Consulting GmbH  
Raiffeisen Street 2B11, 63110, Rodgau, Hessen, Germany  
support@birdfy.com



NETVUE INC.  
1055 East Colorado Boulevard, 5th Floor, Pasadena, CA, 91106  
+1(866)749-0567  
support@birdfy.com



Contains batteries, keep away from fire.  
Enthält Batterien, von Feuer fernhalten.  
Contient des piles, tenir à l'écart du feu.  
Contiene batterie, tenere lontano dal fuoco.  
Contiene baterías, mantener alejado del fuego.



## Contact us:

---



[support@birdfy.com](mailto:support@birdfy.com)



In-App Chat



1(866)749-0567  
Mon-Fri, 9am-5pm, PST

[www.birdfy.com](http://www.birdfy.com)  
© Netvue Inc.