

INSIGNIA™

fire tv

QUICK SETUP GUIDE

55" 4K UHD 60Hz LED TV

NS-55F502NA27 / NS-55F502CA27

INCLUDED ACCESSORIES

Voice Remote with Alexa
and two AAA batteries



TV stands

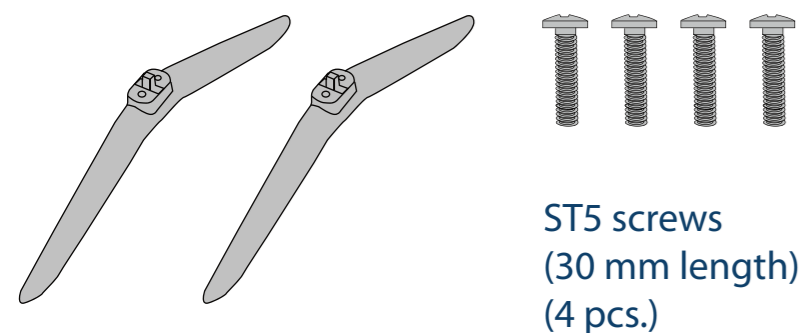

Power cord

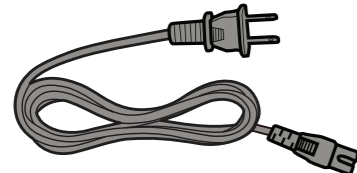

Before using your new TV, read these instructions to prevent any damage. Do not plug your power cord in until all other devices have been connected.

1 INSTALLING THE STANDS OR A WALL MOUNT

Place your TV face-down on a cushioned, clean surface.

STANDS

- 1 Align the TV stand screw holes with the holes on the bottom of your TV.
- 2 Use a Phillips screwdriver and the four screws (included) for your TV to secure the stands to your TV.

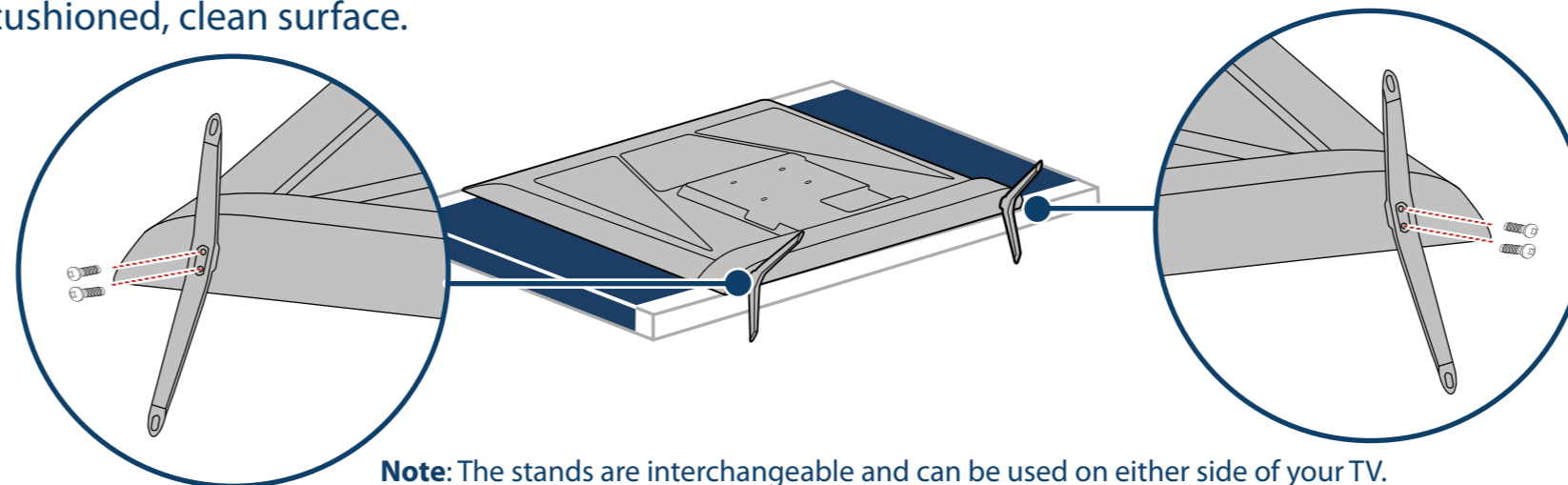

Note: The stands are interchangeable and can be used on either side of your TV.

WALL MOUNT

Before you mount your TV, make sure that:

- Stands are not attached to your TV.
 - The wall-mount bracket supports the weight of your TV.
- See the instructions that came with your wall mount for more information about how to correctly mount your TV.

⚠ WARNING: Your TV has four VESA mounting holes on the back. **You must secure a wall-mount bracket to all four holes.** If you do not use all four holes, your TV may fall and cause property damage or personal injury.

Note: Wall-mount screws are not included.

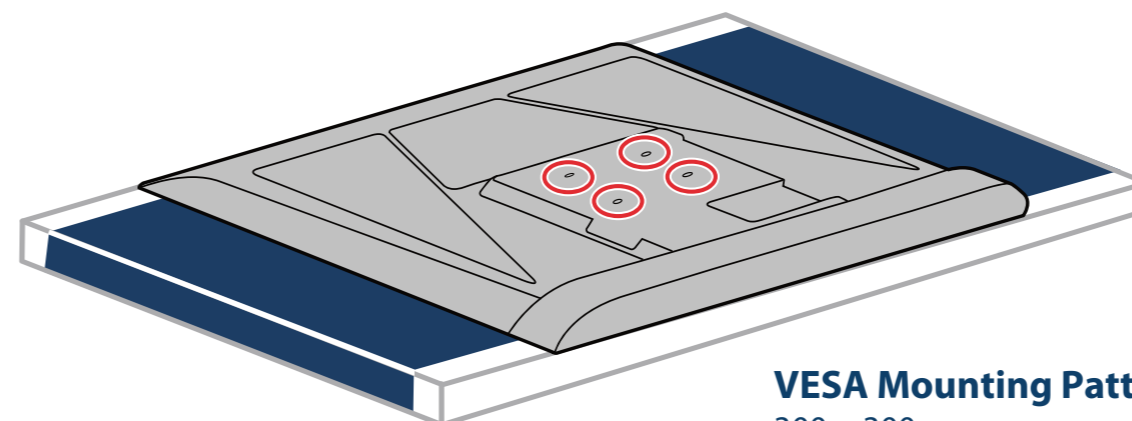

VESA Mounting Pattern

300 × 300 mm
Screws: Type M6,
12 mm to 14 mm length
depending on the wall mount

FEATURES

Power/Input button
Press to turn your TV on or off manually.

Power indicator
Remote control sensor

When your TV is on, a short press changes Power Menu and a long press turns off your TV.

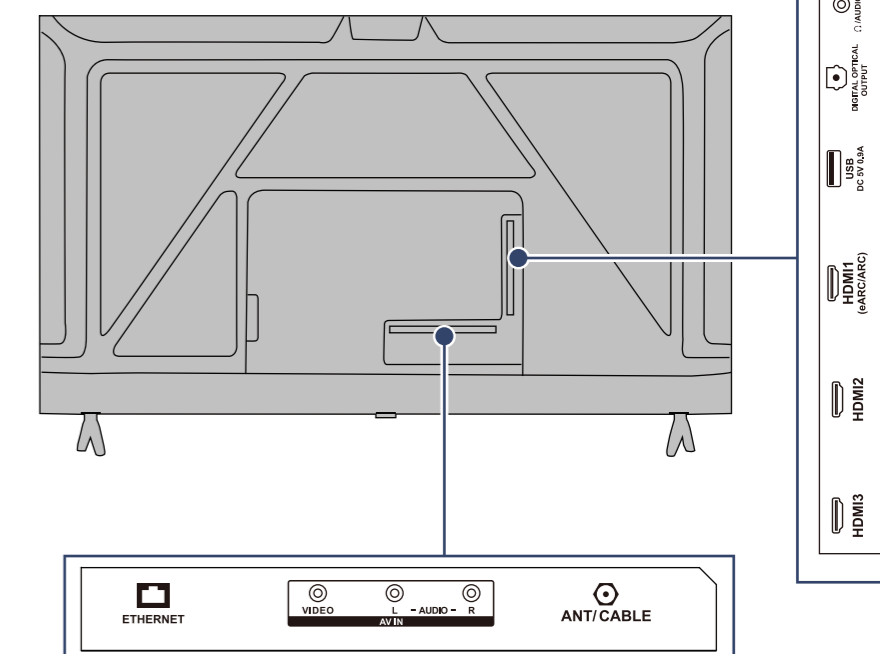
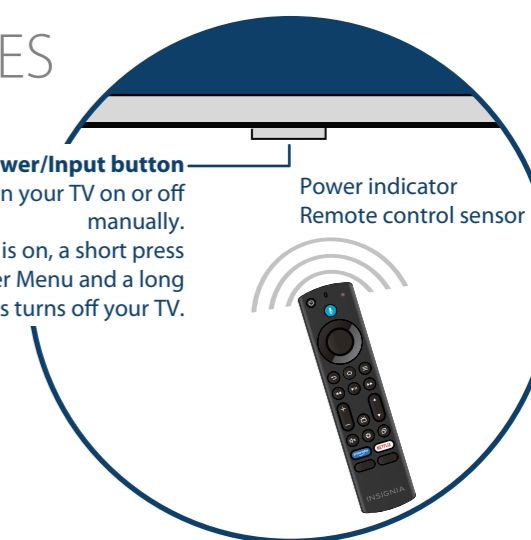

Note: Images do not necessarily represent the exact design of your TV.

2 MAKING CONNECTIONS

HDMI (best video quality)

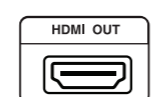

Note: You can use HDMI to connect to other HDMI devices. To use eARC/ARC functionality the connected device must also have HDMI eARC/ARC.

AV (good video quality)



ANT/CABLE (good video quality)

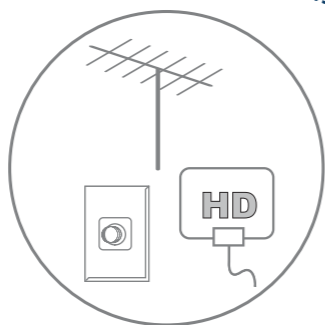

Connect an antenna to access live over-the-air TV.

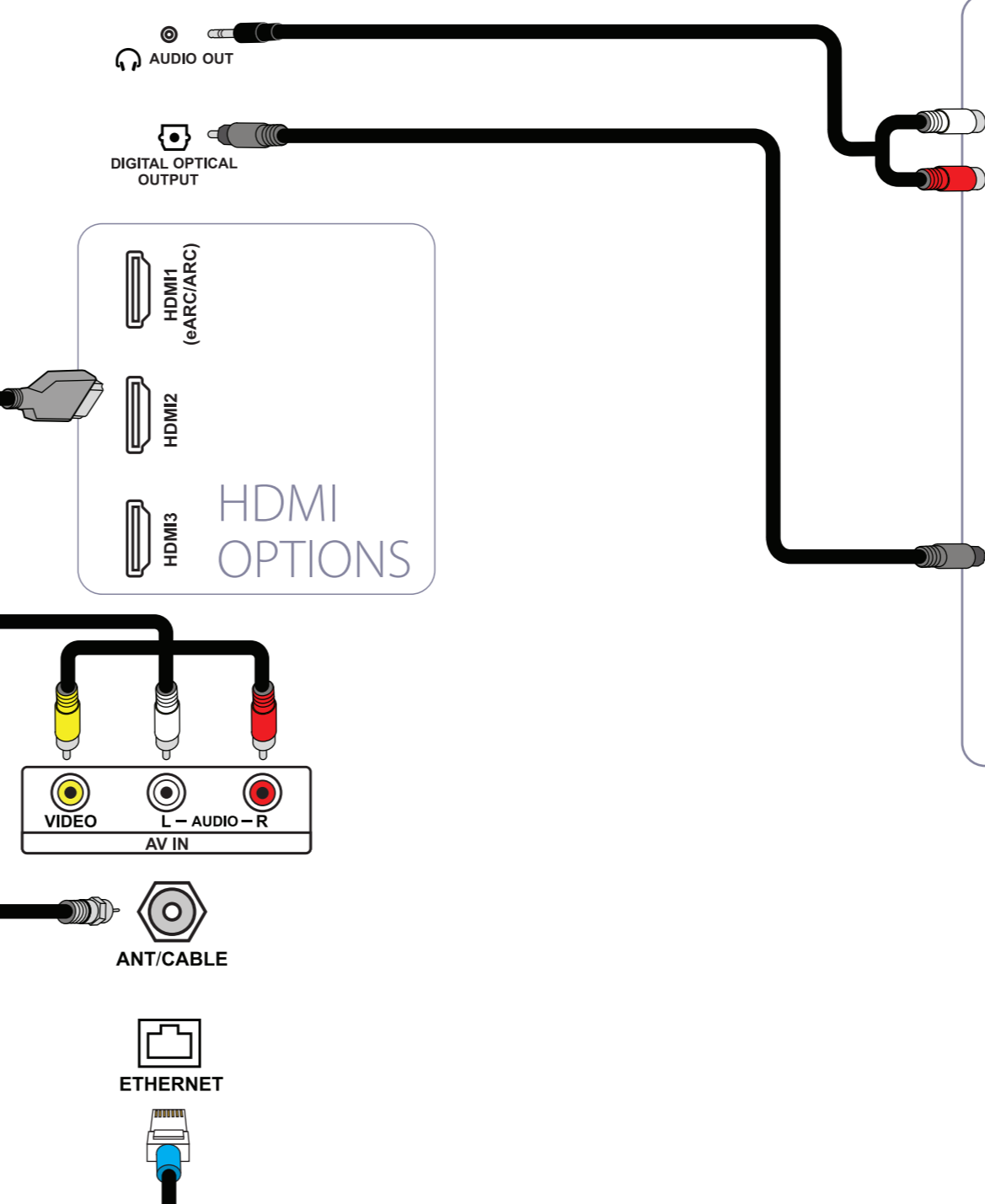

ANALOG

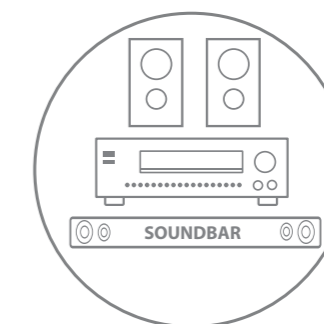
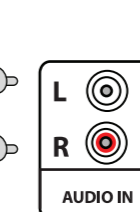

DIGITAL

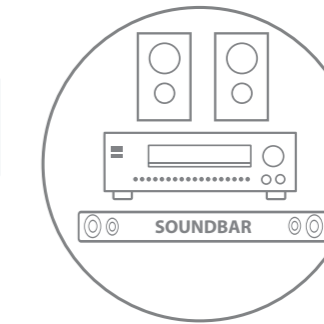
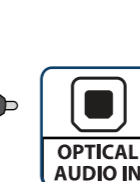

AUDIO OPTIONS

You can use the **DIGITAL OPTICAL OUTPUT** jack or the **HDMI1 (eARC/ARC)** jack. **Note:** If you need to change the digital audio format, go to the **Home** menu, select **Settings**, then select **Display & Sounds**. Select **Audio Output**, then select **Digital Audio Format** and change the setting to **PCM** or your preferred audio format.

ETHERNET (optional)



Note: You can use a wired Ethernet connection to access the internet instead of a Wi-Fi connection. Plug an Ethernet cable into the **ETHERNET** jack on your TV and your Ethernet connection.

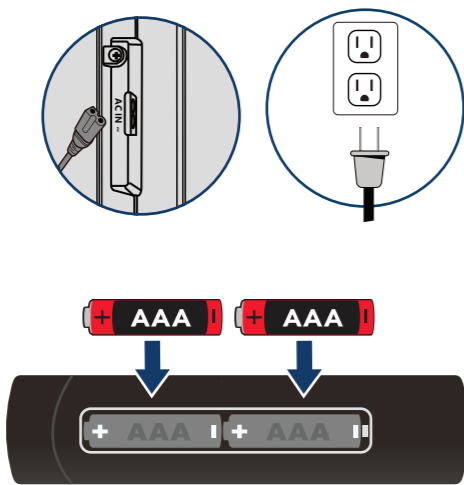

3 TURNING ON YOUR TV

- 1 Plug the power cord (included) into the back of your TV and a power outlet.
- 2 Remove the battery cover on the remote, install two AAA batteries (included), then replace the battery cover.
Tip: Always replace dead batteries with two brand-new AAA batteries from the same manufacturer. Never use damaged batteries. If your remote gets hot during use, stop using and contact customer support immediately.
- 3 Press the  (Power) button on your Voice Remote with Alexa.
- 4 Follow the on-screen instructions.



4 COMPLETING THE ON-SCREEN SETUP

Your TV should automatically pair to your new Voice Remote with Alexa.
Note: A stable internet connection is required in order to complete the on-screen setup.

- 1 If your remote is not paired, long press the  (Home) button for five seconds or until paired. If you continue to have issues, re-insert or replace the batteries and try again.
- 2 Select your Wi-Fi network from the displayed network list.
Note: If your Wi-Fi network is password protected, enter your network password using the on-screen keyboard. If your network is hidden, select the **Join Other Network** tile.*
- 3 Select your experience: **Full** (recommended) or **Basic**.
 - Select **Full** to access live TV, over tens of thousands of streaming movies and TV episodes, thousands of apps, and Alexa skills. To get started, sign into or sign up for a free Amazon account.
 - Select **Basic** to access live TV and the five preset streaming apps. Alexa and the full App Store are not included.
- 4 If you connected your TV to an antenna or cable wall jack:
 - A Go to **Settings > Live TV > Channel Scan**.
 - B Follow the on-screen instructions to scan for channels.**Note:** To browse and watch live TV, use the **On Now** row or press the  (Guide) button on your Voice Remote with Alexa.

USING YOUR VOICE REMOTE WITH ALEXA



FIND YOUR *USER GUIDE* ONLINE

- 1 Go to www.insigniaproducts.com.
- 2 Use the search bar to find **NS-55F502NA27 / NS-55F502CA27**.
- 3 Select **Support & Downloads**.
- 4 Next to *User Guide*, select the language you want.

For Troubleshooting information, see your online *User Guide*.

INSIGNIA™

fire tv

A Smarter TV Is Here
4K Picture Quality, Fire TV Experience Built-in,
Voice Remote with Alexa

 Stream more than 1.8 million movies and TV episodes from Netflix, Prime Video, Disney+, HBO Max, and more.

 Access over 1 million free movies and TV episodes from popular ad-supported streaming apps like Fire TV Channels, Tubi, and Pluto TV.

 Fire TV lets you stream your shows and run your home, all-in-one convenient place without missing a scene.

Full Experience required to access all features described.

ONE-YEAR LIMITED WARRANTY
Visit www.insigniaproducts.com for details.

NEED ADDITIONAL HELP?
Check out our **Support Community** at www.insigniaproducts.com for helpful information from other Insignia TV owners.

WE'RE HERE FOR YOU
www.insigniaproducts.com
For customer service, call: **1-877-467-4289** (U.S./Canada)

CONTACT AMAZON FIRE TV CUSTOMER SERVICE
www.amazon.com/deviceservices/support



Manufactured under license from DTS, Inc. and/or its affiliates. For patents, see <https://xperi.com/dts-patents/>. DTS, the DTS logo, DTS:X, the DTS:X logo, Virtual:X, and the DTS Virtual:X logo are trademarks or registered trademarks of DTS, Inc. and/or its affiliates in the U.S. and/or other countries. © DTS, Inc. and/or its affiliates. All rights reserved.

AMAZON TERMS & POLICIES
Before using Fire TV Edition, please read the terms located at www.amazon.com/deviceservices/support. Please also read all terms and policies for services related to Fire TV Edition, including but not limited to Amazon's Privacy Notice located at www.amazon.com/privacy, Amazon's Conditions of Use located at www.amazon.com/conditionsofuse, and any other terms or usage provisions available at www.amazon.com/deviceservices/support. All terms, rules, notices, policies, and provisions are, collectively, the "Agreements." By using Fire TV Edition, you agree to be bound by the terms of the Agreements.

Amazon, Fire, and all related marks are trademarks of Amazon.com, Inc. or its affiliates.

Certain services are subject to change at any time, may not be available in all areas and languages, or in 4K UHD, and may require separate subscriptions or withdrawal.

Dolby, Dolby Audio, and the double-D symbol are trademarks of Dolby Laboratories Licensing Corporation. Manufactured under license from Dolby Laboratories. Confidential unpublished works. Copyright © 1992-2019 Dolby Laboratories. All rights reserved.

*Wi-Fi signals can be inconsistent the further away from the source, and can be impacted by walls/floors between the TV and source.

U.S. and Canada:
INSIGNIA is a trademark of Best Buy and its affiliated companies.
Distributed by Best Buy Purchasing, LLC
Richfield, MN 55423
©2025 Best Buy. All rights reserved.