

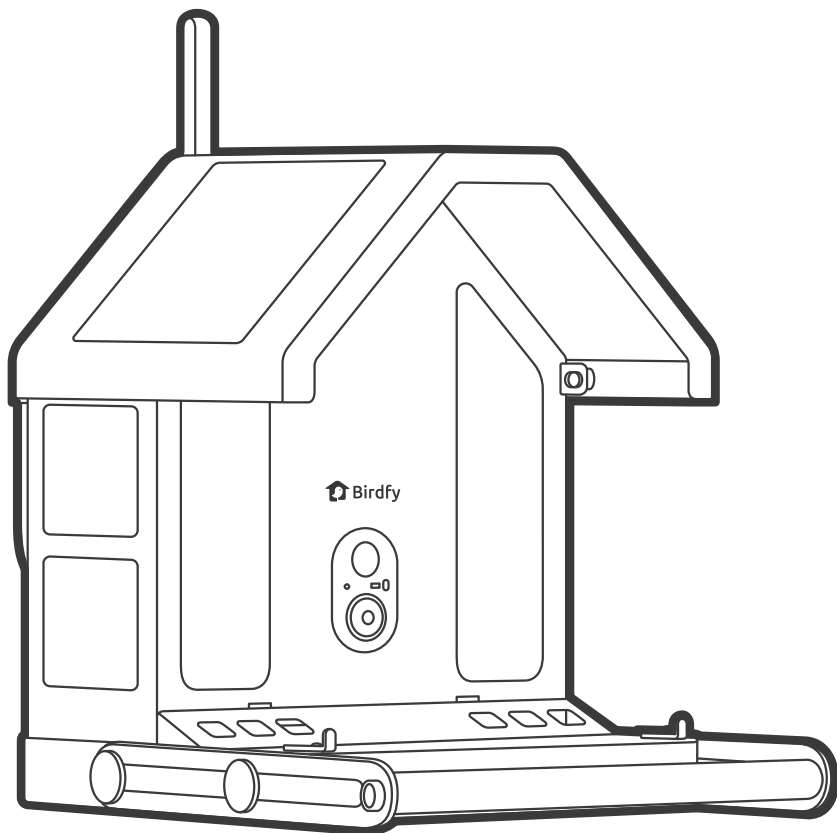

# User Manual

Birdfy Feeder Metal 2 4K



EN

ES

FR

# Catalog

## PRODUCT OVERVIEW

What's in the Box .....	1-4
Product Diagram .....	5-6

## CAMERA GUIDE

Camera Diagram .....	7-8
Charge Before Use .....	9
Button Guidance .....	10-13
Camera Status Light .....	14-16

## INSTALLATION AND USE

Step 1: Download the Birdfy App .....	17
Step 2: Pair the Camera with the App .....	17-18
Step 3: Assemble the Product .....	19-22
Step 4: Outdoor Installation .....	23-31
Step 5: Add Birdseed .....	32
Step 6: Adjust the Perch .....	33

## MAINTENANCE

Cleaning .....	34-35
----------------	-------

## SUPPORT AND COMMUNITY

Support .....	36-37
The Birdfy Community .....	38

<b>WARNING</b> .....	39-41
----------------------	-------

# Catálogo

## DESCRIPCIÓN DEL PRODUCTO

Qué hay en la caja .....	1-4
Diagrama del producto .....	5-6

## GUÍA DE LA CÁMARA

Diagrama de la cámara .....	7-8
Cargar antes de usar .....	9
Guía de botones .....	10-13
Luz de estado de la cámara .....	14-16

## INSTALACIÓN Y USO

Paso 1: Descargar la aplicación Birdfy .....	17
Paso 2: Vincular la cámara con la aplicación .....	17-18
Paso 3: Ensamblar el producto .....	19-22
Paso 4: Instalación en exteriores .....	23-31
Paso 5: Añadir alpiste .....	32
Paso 6: Ajusta el posadero .....	33

## MANTENIMIENTO

Limpieza .....	34-35
----------------	-------

## SOPORTE Y COMUNIDAD

Soporte .....	36-37
La Comunidad Birdfy .....	38

<b>ADVERTENCIA</b> .....	39-41
--------------------------	-------

# Catalogue

## PRÉSENTATION DU PRODUIT

Contenu de la boîte .....	1-4
Schéma du produit .....	5-6

## GUIDE DE LA CAMÉRA

Schéma de la caméra .....	7-8
Charger avant utilisation .....	9
Guide des boutons .....	10-13
Le voyant d'état de la caméra .....	14-16

## INSTALLATION ET UTILISATION

Étape 1 : Télécharger l'application Birdfy .....	17
Étape 2 : Appairer la caméra avec l'application .....	17-18
Étape 3 : Assembler le produit .....	19-22
Étape 4 : Installation en extérieur .....	23-31
Étape 5 : Ajouter des graines pour oiseaux .....	32
Étape 6 : Ajustez le perchoir .....	33

## ENTRETIEN

Nettoyage .....	34-35
-----------------	-------

## SUPPORT ET COMMUNAUTÉ

Assistance .....	36-37
La Communauté Birdfy .....	38

<b>AVERTISSEMENT</b> .....	39-41
----------------------------	-------

# What's in the Box

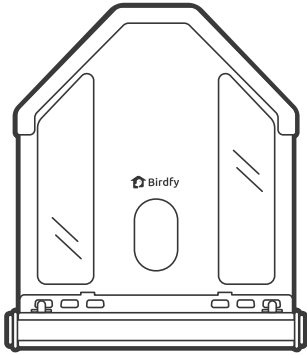

Metal Feeder  
Alimentador metálico  
Mangeoire en métal

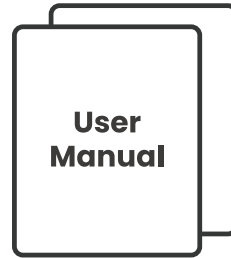

User Manual + Birding Tips  
Manual de usuario + Tips de aves  
Manuel utilisateur + Astuces oiseaux



Camera  
Cámara  
Caméra

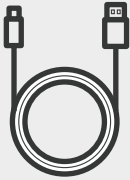

Charging cable  
Cable de carga  
Câble de charge

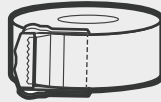

Black strap  
Correa negra  
Sangle noire

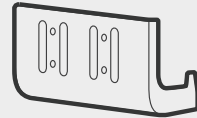

Hanging bracket  
Soporte colgante  
Support mural

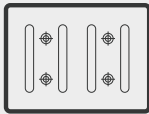

Drilling template  
Plantilla de perforación  
Gabarit de perçage

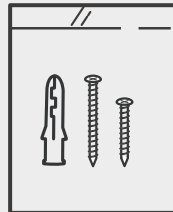

**A**

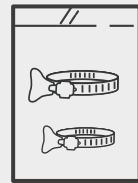

**B**

## PRODUCT OVERVIEW

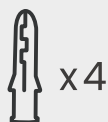
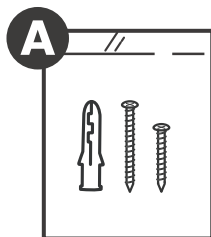

Anchors  
Tacos  
Chevilles



Screws for mounting  
on wood  
Tornillos para montaje  
en madera  
Vis pour fixation sur bois



Screws for mounting  
on concrete  
Tornillos para montaje  
en hormigón  
Vis pour fixation sur béton

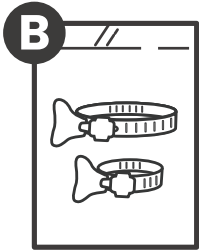

Hose clips (large)  
Clips para  
manguera (grandes)  
Colliers de  
serrage (grands)



Hose clips (small)  
Clips para  
manguera (pequeños)  
Colliers de  
serrage (petits)

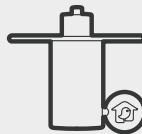

Pole-top adapter  
Adaptador superior  
para poste  
Adaptateur pour  
poteau

# Product Diagram

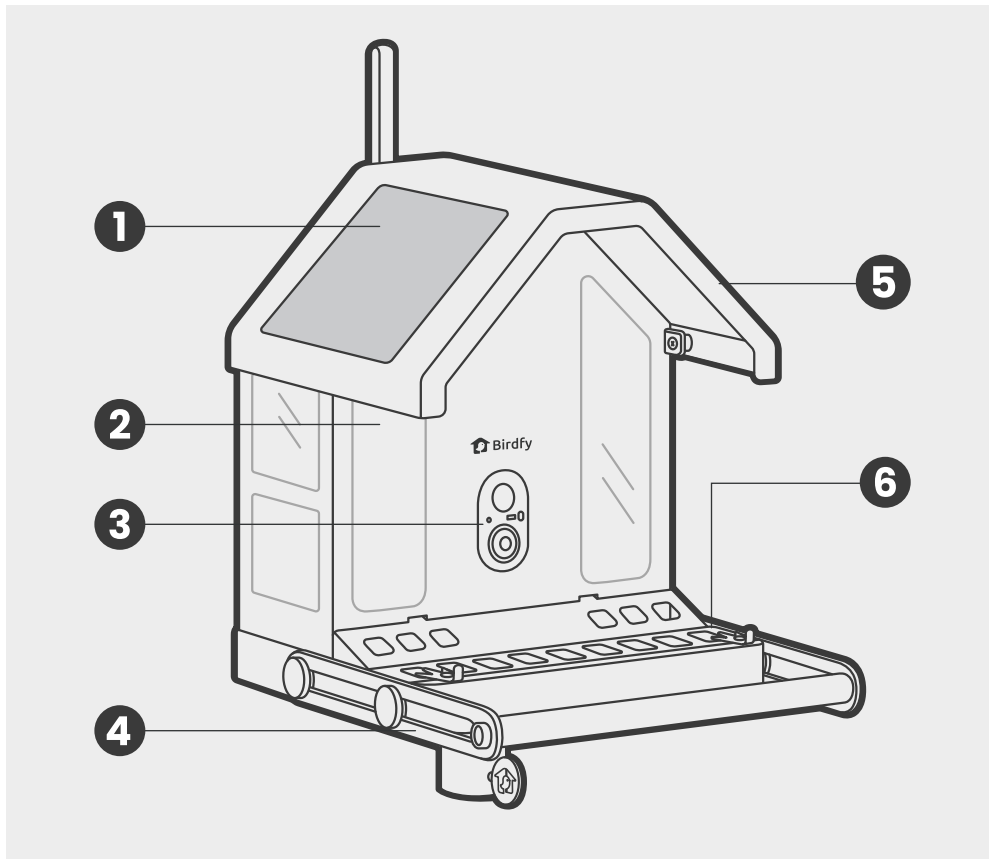

**1** Solar panel  
Panel solar  
Panneau solaire

**2** Acrylic seed container  
Contenedor acrílico para semillas  
Conteneur à graines en acrylique

**3** Camera  
Cámara  
Caméra

**4** Wooden perch  
Posadero de madera  
Perchoir en bois

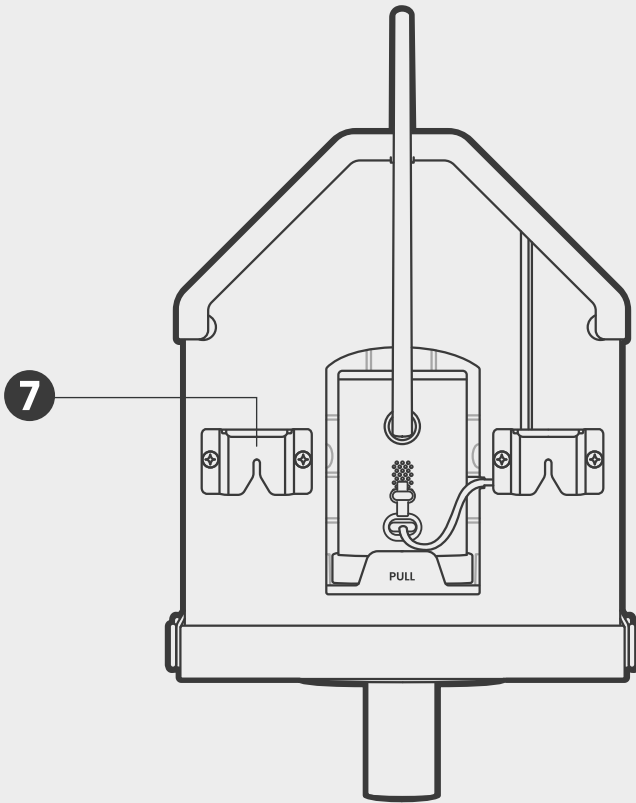

At the back

**5** Feeder lid  
Tapa del comedero  
Couvercle de la mangeoire

**6** Seed guard  
Protector de semillas  
Protection pour graines

**7** Mounting bracket  
Soporte de montaje  
Soporte de montage

# Camera Diagram

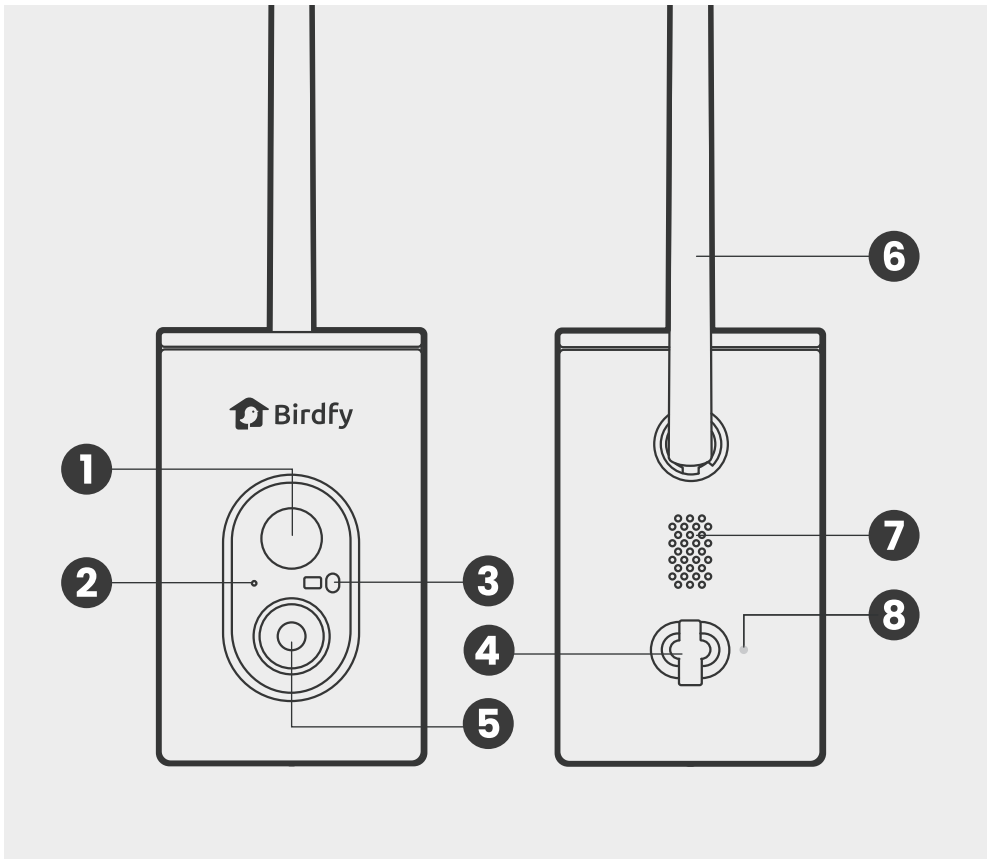

- 1** Motion sensor  
Sensor de movimiento  
Capteur de mouvement
- 3** Dual-mode illumination  
Iluminación de doble modo  
Éclairage double mode

- 2** Microphone  
Micrófono  
Microphone
- 4** Charging port  
Puerto de carga  
Port de charge

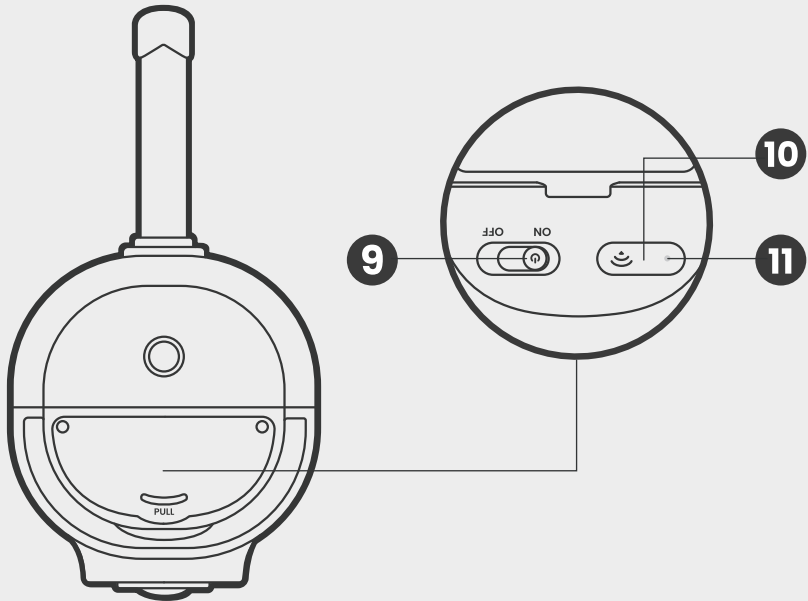

At the bottom

- |  |   |  |
|--|---|--|
| <p><b>5</b> Wide-angle lens<br/>Lente gran angular<br/>Objectif grand angle</p>              | <p><b>6</b> Antenna<br/>Antena<br/>Antenne</p>  | <p><b>7</b> Speaker<br/>Altavoz<br/>Haut-parleur</p> |
| <p><b>8</b> Charging status light<br/>Luz de estado de carga<br/>Voyant d'état de charge</p> | <p><b>9</b> Power switch<br/>Interruptor de encendido<br/>Interrupteur d'alimentation</p> |  |
| <p><b>10</b> Wi-Fi pairing button<br/>Emparejar Wi-Fi<br/>Appairage Wi-Fi</p>                | <p><b>11</b> Pairing status light<br/>Luz de emparejamiento<br/>Voyant d'appairage</p>    |  |

## Charge Before Use

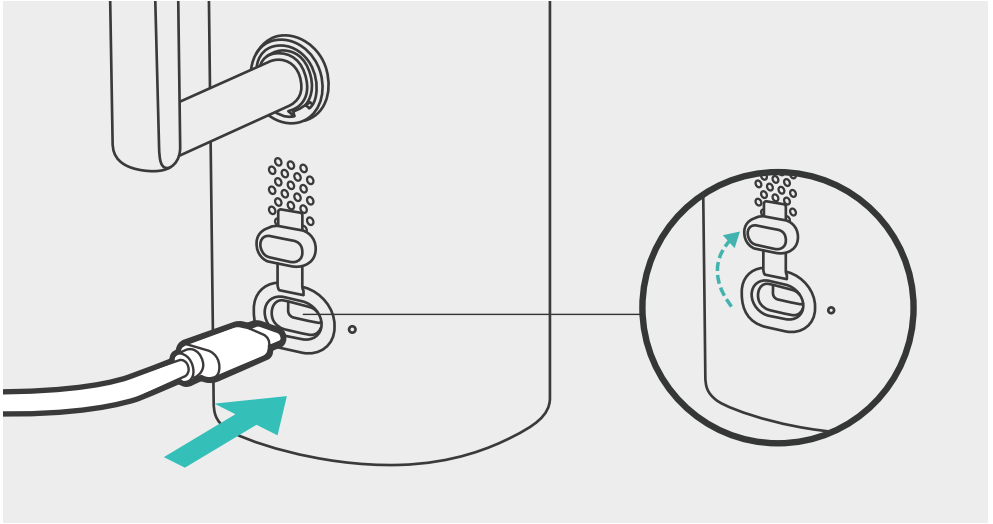

### **Fully charge the camera before use**

For safety reasons, the camera is not fully charged when packaged. Please use the included charging cable (DC 5V / 2A) found in the accessory box to fully charge the camera before first use.

### **Carga completamente la cámara antes de usarla**

Por motivos de seguridad, la cámara no viene completamente cargada cuando se envasa. Utiliza el cable de carga incluido (DC 5V / 2A) que se encuentra en la caja de accesorios para cargar completamente la cámara antes del primer uso.

### **Chargez complètement la caméra avant de l'utiliser**

Pour des raisons de sécurité, la caméra n'est pas entièrement chargée lors de l'emballage. Veuillez utiliser le câble de charge fourni (DC 5V / 2A) présent dans la boîte d'accessoires pour charger complètement la caméra avant la première utilisation.

# Button Guidance

## Powering On for the First Time:

- 1** Take the camera out of the box and position the antenna vertically, pointing straight up.  
Saca la cámara de la caja y coloca la antena vertical, apuntando hacia arriba.  
Sortez la caméra de la boîte et positionnez l'antenne verticalement, pointant vers le haut.

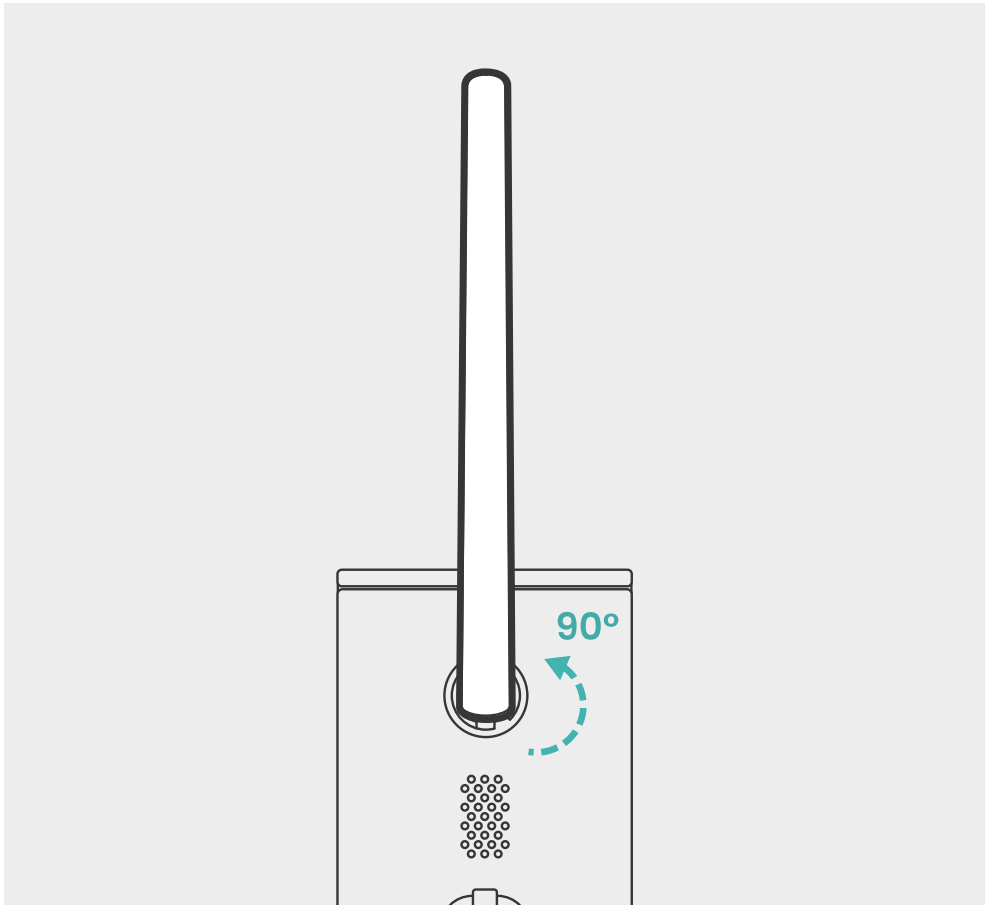

## CAMERA GUIDE

- 2** Open the waterproof cover at the bottom of the camera.  
Abre la cubierta impermeable en la parte inferior de la cámara.  
Ouvrez le couvercle étanche au bas de la caméra.

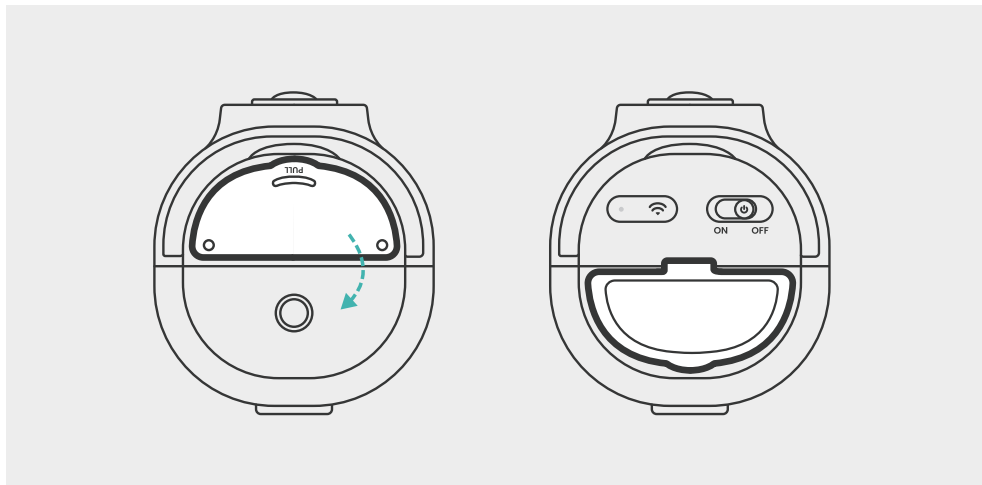

- 3** Slide the power switch to ON. The camera will power up, and the blue indicator light next to the button will turn on.  
Desliza el interruptor de encendido a ON. La cámara se encenderá y se iluminará la luz indicadora azul junto al botón.  
Faites glisser l'interrupteur d'alimentation sur ON. La caméra s'allumera et le voyant bleu à côté du bouton s'allumera.

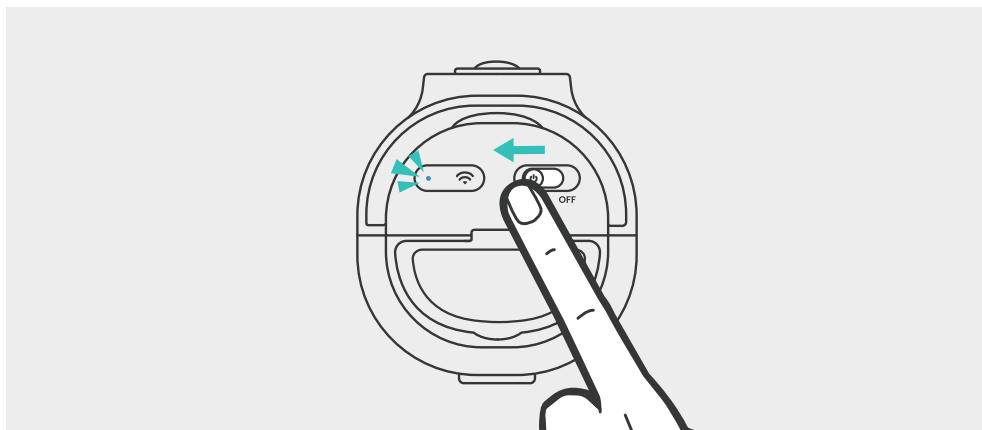

## Power Off:

Slide the power switch to OFF to turn off the camera.

Desliza el interruptor de encendido a OFF para apagar la cámara.

Faites glisser l'interrupteur d'alimentation sur OFF pour éteindre la caméra.

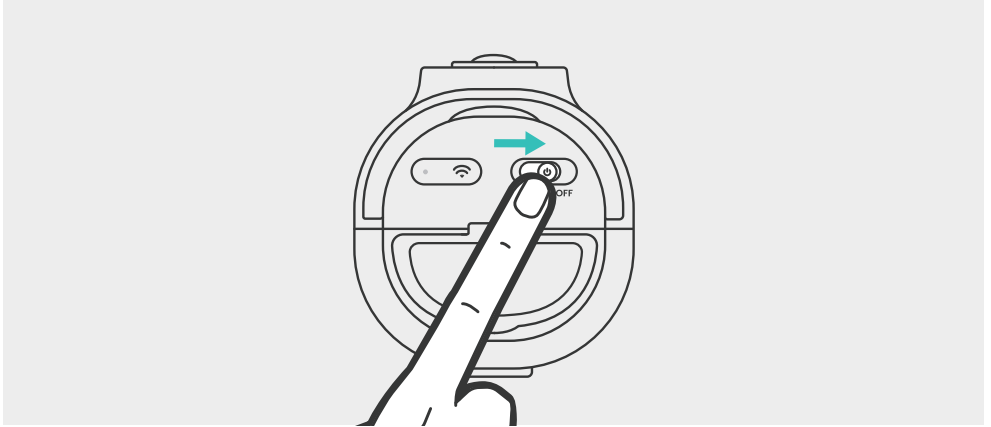

- \*Download the Birdfy app and follow the in-app steps to pair the camera with the app. (For detailed download instructions, please refer to page 17.)
- \*Descarga la aplicación Birdfy y sigue los pasos dentro de la app para emparejar la cámara con ella. (Para instrucciones detalladas de descarga, consulta la página 17.)
- \*Téléchargez l'application Birdfy et suivez les étapes dans l'application pour jumeler la caméra. (Pour des instructions détaillées de téléchargement, voir page 17.)

### Wi-Fi Pairing:

Press the Wi-Fi pairing button twice briefly to enter pairing mode.

Presiona brevemente el botón de emparejamiento Wi-Fi dos veces para entrar en modo de emparejamiento.

Appuyez brièvement deux fois sur le bouton d'appairage Wi-Fi pour entrer en mode appairage.

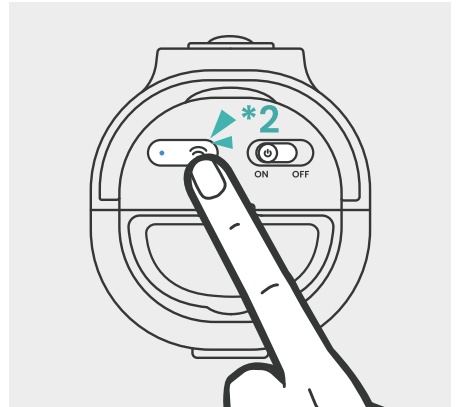

### Exit Pairing Mode:

Slide the power switch to OFF to exit pairing mode and turn off the camera.

Desliza el interruptor de encendido a OFF para salir del modo de emparejamiento y apagar la cámara.

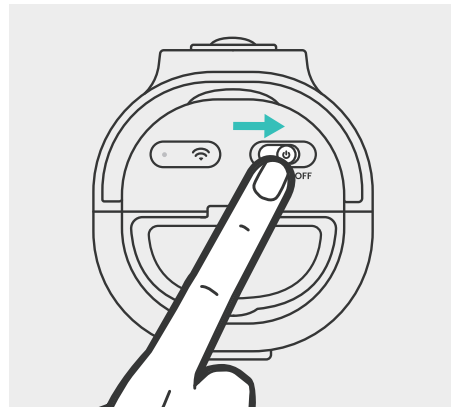

Faites glisser l'interrupteur d'alimentation sur OFF pour quitter le mode appairage et éteindre la caméra.

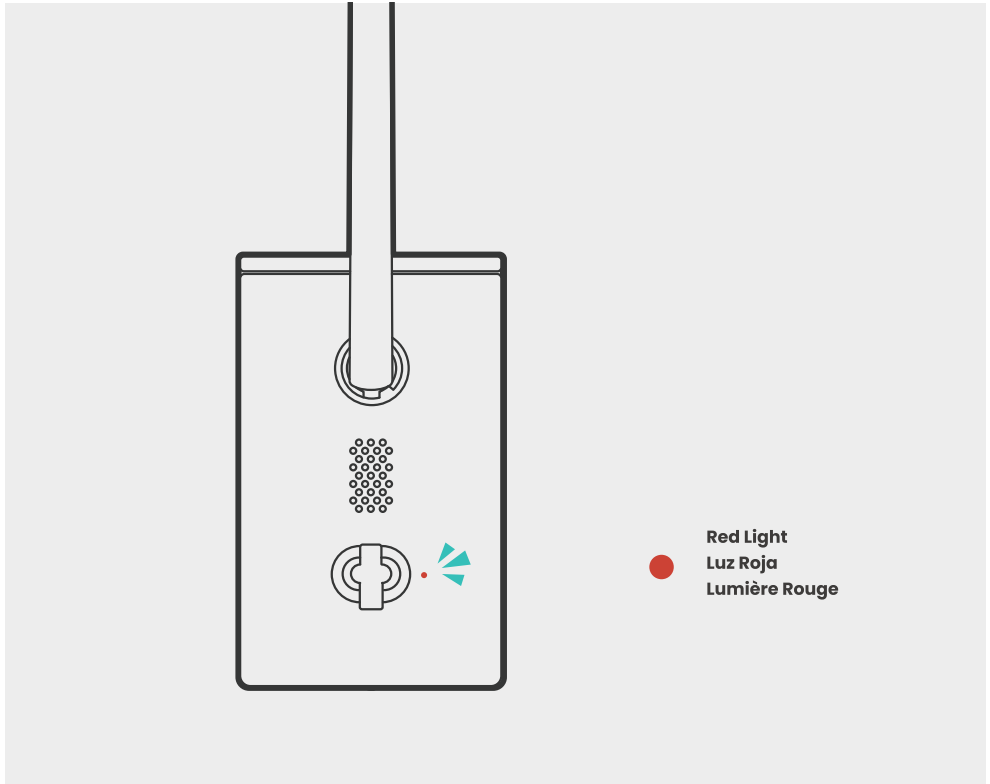

# Camera Status Light

## Charging status light



<b>Status Light</b> <b>Luz de estado</b> <b>Le voyant d'état</b>	<b>Description</b> <b>Descripción</b> <b>Description</b>
 <b>Red Light</b> <b>Luz Roja</b> <b>Lumière Rouge</b>	Charging in progress Cargando Charge en cours.
 <b>No Light</b> <b>Sin luz</b> <b>Aucune lumière</b>	Fully charged or not connected to power. Completamente cargada o no conectada a la corriente. Batterie complètement chargée ou non connectée à l'alimentation.

## Pairing status light

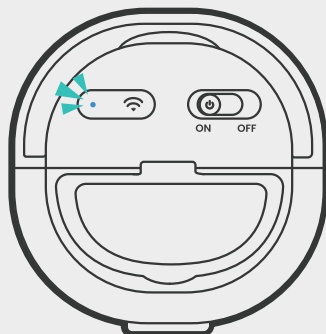

- **Blue Light**  
**Luz Azul**  
**Lumière Bleue**
- **Yellow Light**  
**Amarillo**  
**Jaune**

Status Light Luz de estado Le voyant d'état		Description Descripción Description
<span style="color: blue;">●</span> <b>Blue Light</b> <b>Luz Azul</b> <b>Lumière Bleue</b>	<span style="color: blue;">●</span> Steady On Encendida Allumée en continu	Camera is on and operating normally La cámara está encendida y funcionando con normalidad La caméra est allumée et fonctionne normalement
	<span style="color: blue;">●</span> Flashing Parpadeando Clignotante	Wi-Fi configuration mode Modo de configuración Wi-Fi Mode de configuration Wi-Fi
<span style="color: yellow;">●</span> <b>Yellow Light</b> <b>Amarillo</b> <b>Jaune</b>	<span style="color: yellow;">●</span> Flashes twice Parpadea dos veces Clignote deux fois	Low battery, but the camera can still operate. Batería baja, pero la cámara aún puede funcionar. Batterie faible, mais la caméra peut encore fonctionner.
	<span style="color: yellow;">●</span> Flashes four times Parpadea cuatro veces Clignote quatre fois	Critically low battery. Please charge as soon as possible. The camera cannot start at this point. Batería críticamente baja. Cárgala cuanto antes; la cámara no puede arrancar en este estado. Batterie critique. Veuillez charger dès que possible. La caméra ne peut pas démarrer.
<span style="color: gray;">●</span> <b>No Light</b> <b>Sin luz</b> <b>Pas de lumière</b>	The camera is either in sleep mode or powered off. La cámara está en modo de suspensión o apagada. La caméra est soit en mode veille, soit éteinte.	

### What to Do If There Is No Light :

1. Make sure the power switch is in the ON position and the camera is turned on.
2. Then press the Wi-Fi pairing button once to check the status:
  - If the blue light turns on briefly and then goes off: The camera is in Sleep Mode, operating in the background to save power.
  - If there is no response or the yellow light flashes rapidly: The camera's battery is depleted. Please charge it promptly.

### Qué hacer si no hay luz :

1. Asegúrate de que el interruptor de encendido esté en ON y la cámara esté encendida.
2. Presiona una vez el botón de emparejamiento Wi-Fi para comprobar el estado:
  - Si la luz azul se enciende brevemente y luego se apaga: La cámara está en modo de suspensión, funcionando en segundo plano para ahorrar energía.
  - Si no hay respuesta o la luz amarilla parpadea rápidamente: La batería está agotada. Cárgala lo antes posible.

### Que faire si aucune lumière n'apparaît

1. Assurez-vous que l'interrupteur d'alimentation est sur ON et que la caméra est allumée.
2. Appuyez une fois sur le bouton d'appairage Wi-Fi pour vérifier le statut :
  - Si le voyant bleu s'allume brièvement puis s'éteint : La caméra est en mode veille, fonctionnant en arrière-plan pour économiser de l'énergie.
  - S'il n'y a aucune réponse ou si le voyant jaune clignote rapidement : La batterie est déchargée. Veuillez la recharger immédiatement.



When charging and operating, both the ambient temperature and camera temperature should be within 14°F to 113°F (-10°C to 45°C). If the camera has been exposed to low temperatures for an extended period, it should be brought back to room temperature before charging.

Durante la carga y el funcionamiento, tanto la temperatura ambiente como la de la cámara deben estar entre 14°F y 113°F (-10°C a 45°C). Si la cámara ha estado expuesta a bajas temperaturas durante un período prolongado, debe llevarse a temperatura ambiente antes de cargarla.

Lors de la charge et de l'utilisation, la température ambiante et celle de la caméra doivent se situer entre 14°F et 113°F (-10°C à 45°C). Si la caméra a été exposée à des températures basses pendant une période prolongée, elle doit être ramenée à température ambiante avant la recharge.

## Step 1: Download the Birdfy App



Download on the  
**App Store**

GET IT ON  
**Google Play**

## Step 2: Pair the Camera with the App

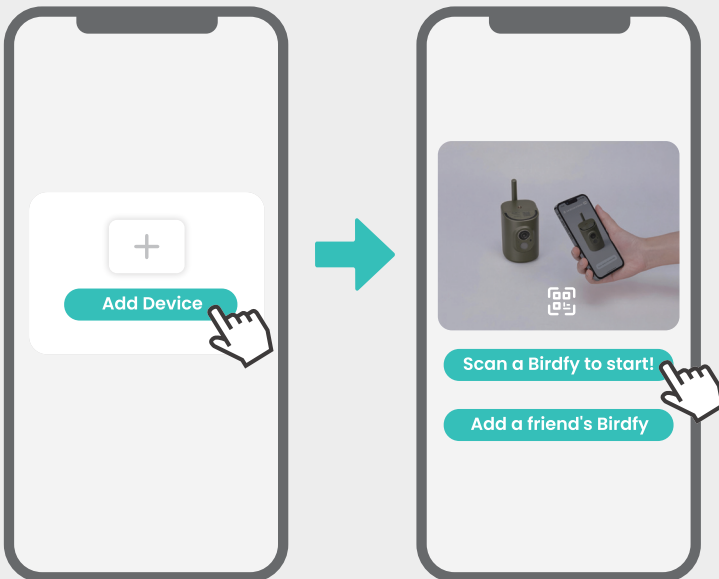

\*Follow the in-app instructions to set up your Birdfy

\*Sigue las instrucciones dentro de la aplicación para configurar tu Birdfy

\*Suivez les instructions dans l'application pour configurer votre Birdfy

## Bird Identification

- For product labeled **Lifetime Free AI**, the bird identification feature is included and activated automatically, no further action is needed.
- For product labeled **AI by Subscription**, you need to subscribe on [my.birdfy.com](https://my.birdfy.com) to access this feature.

## Identificación de aves

- Para productos etiquetados como **IA gratuita de por vida**, la función de identificación de aves está incluida y se activa automáticamente, no se necesita ninguna acción adicional.
- Para productos etiquetados como **IA por suscripción**, debe suscribirse en [my.birdfy.com](https://my.birdfy.com) para acceder a esta función.

## Identification des oiseaux

- Pour les produits étiquetés **IA gratuite à vie**, la fonction d'identification des oiseaux est incluse et activée automatiquement, aucune action supplémentaire n'est requise.
- Pour les produits étiquetés **IA par abonnement**, vous devez vous abonner sur [my.birdfy.com](https://my.birdfy.com) pour accéder à cette fonction.

## Step 3: Assemble the Product

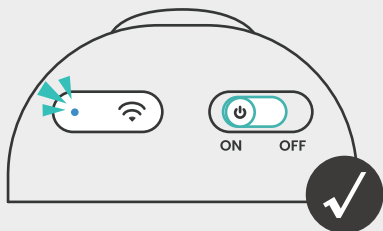

\*Before starting, please ensure the camera has been paired with the app and is powered on.

\*Antes de comenzar, asegúrese de que la cámara esté emparejada con la aplicación y encendida.

\*Avant de commencer, assurez-vous que la caméra est appairée avec l'application et qu'elle est allumée.

- 1** Pull out the camera tray from the back of the feeder.  
Extrae la bandeja de la cámara desde la parte trasera del comedero.  
Retirez le plateau de la caméra à l'arrière de la mangeoire. Placez la caméra appairée sur le plateau.

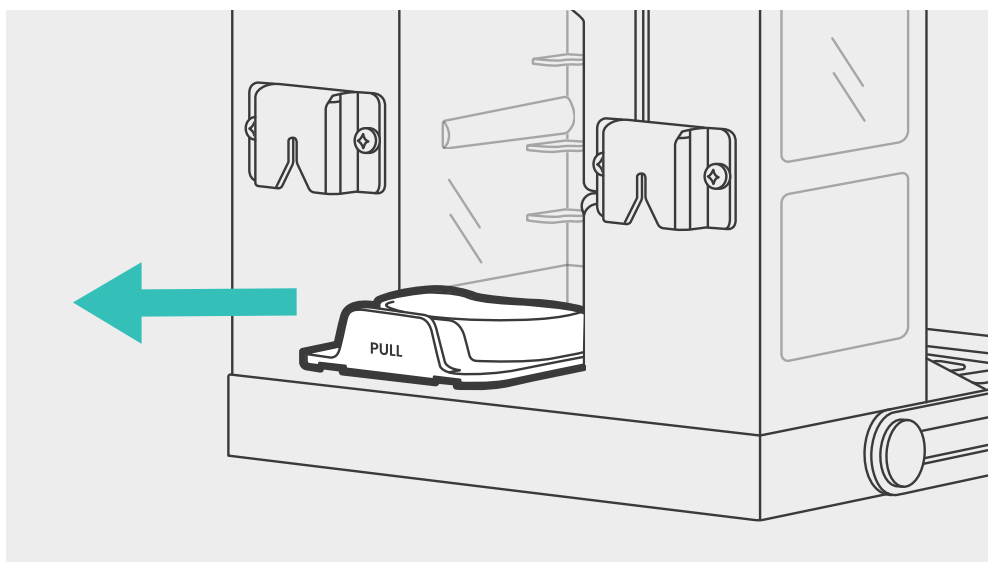

- 2** Insert the paired camera onto the tray.  
 Inserta la cámara emparejada en la bandeja.  
 Placez la caméra appairée sur le plateau.

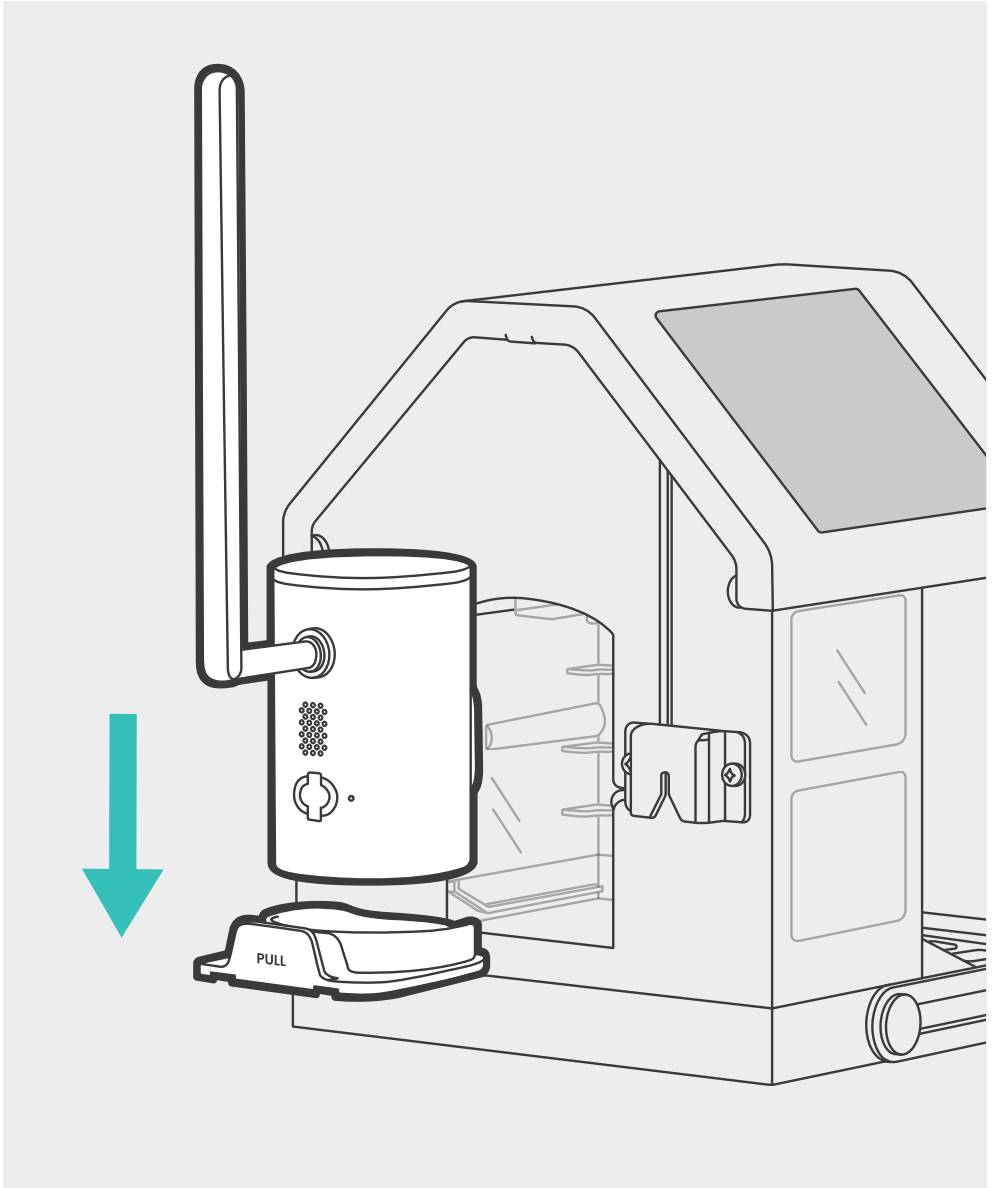

## INSTALLATION AND USE

- 3** Connect the camera to the solar panel.  
Conecta la cámara al panel solar.  
Connectez la caméra au panneau solaire.

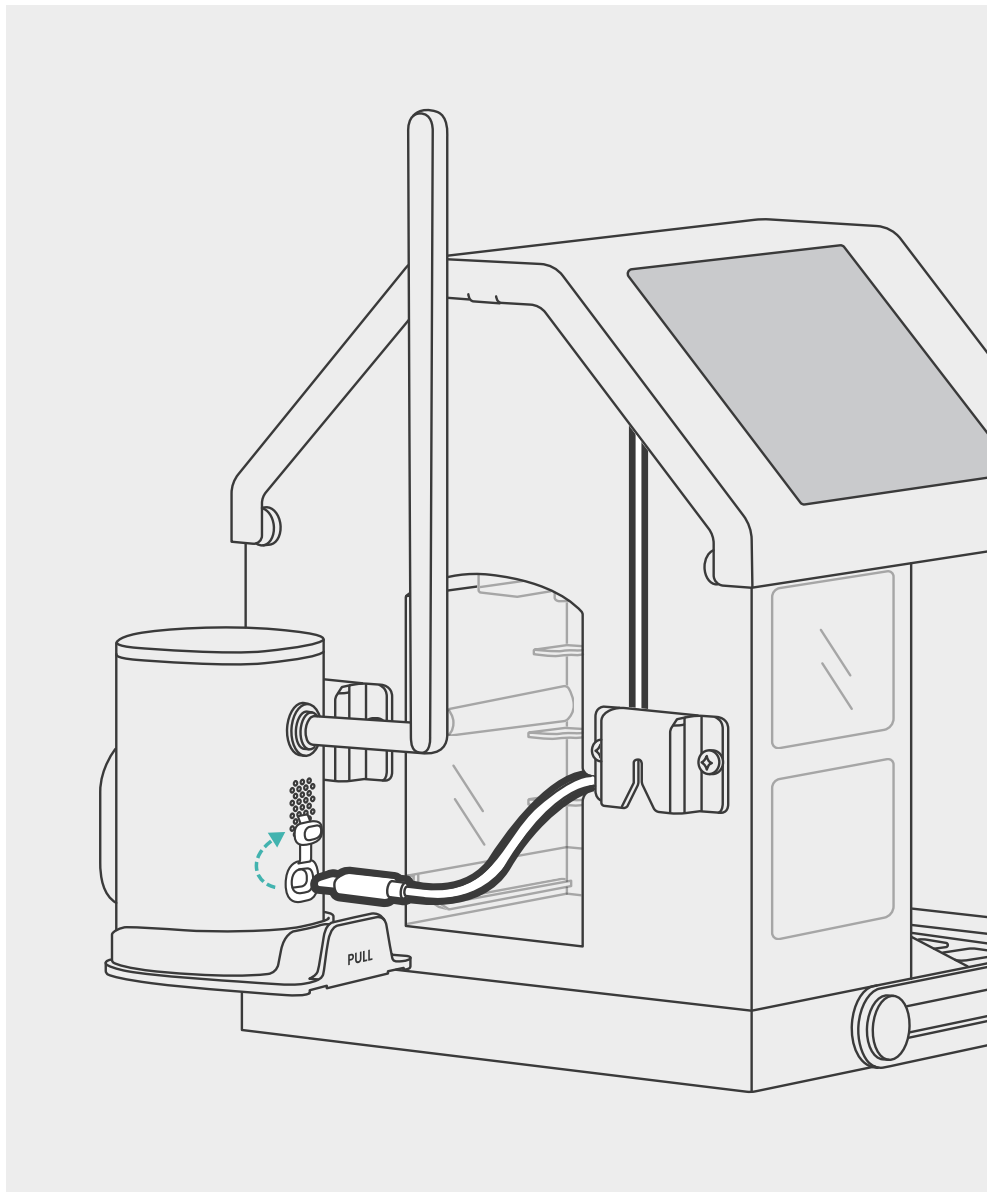

4

Slide the camera and tray back into the camera compartment.  
 Desliza la cámara y la bandeja de nuevo en el compartimento de la cámara.

Faites glisser la caméra et le plateau dans le compartiment de la caméra.

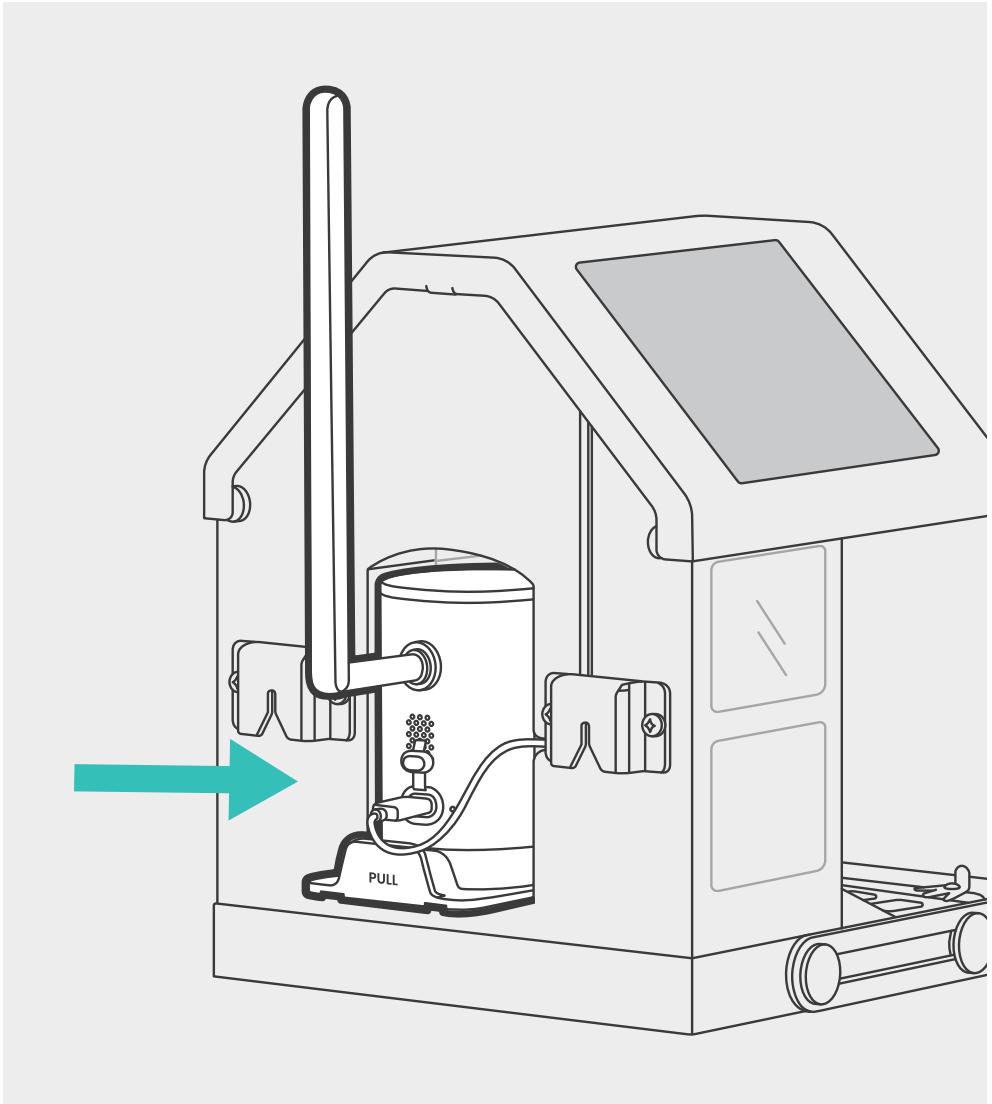

## Step 4: Outdoor Installation

### A. Pole-mount



Hose clips (large/small)

Clips para manguera (grandes/pequeños)

Pinces pour tuyau (grands/petits)

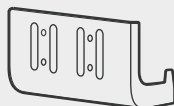

Hanging bracket

Soporte colgante

Support mural

1

Loosen the hose clip.

Afloje la abrazadera de la manguera.

Desserrer le collier de serrage pour tuyau.

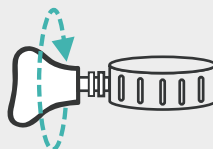

2

Wrap the hose clip around the hanging bracket.

Envuelva la abrazadera de la manguera alrededor del soporte de suspensión.

Enrouler le collier de serrage autour du support de suspension.

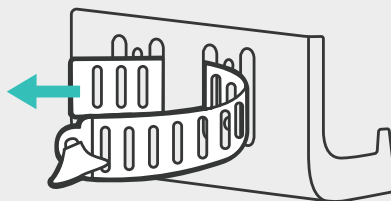

- 3** Attach the hanging bracket to the pole.  
 Coloque el soporte de suspensión en el poste.  
 Fixer le support de suspension sur le poteau.

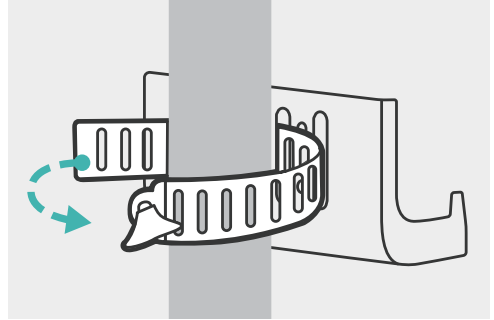

- 4** Hang the feeder on the pole.  
 Cuelgue el comedero en el poste.  
 Accrocher le distributeur sur le poteau.

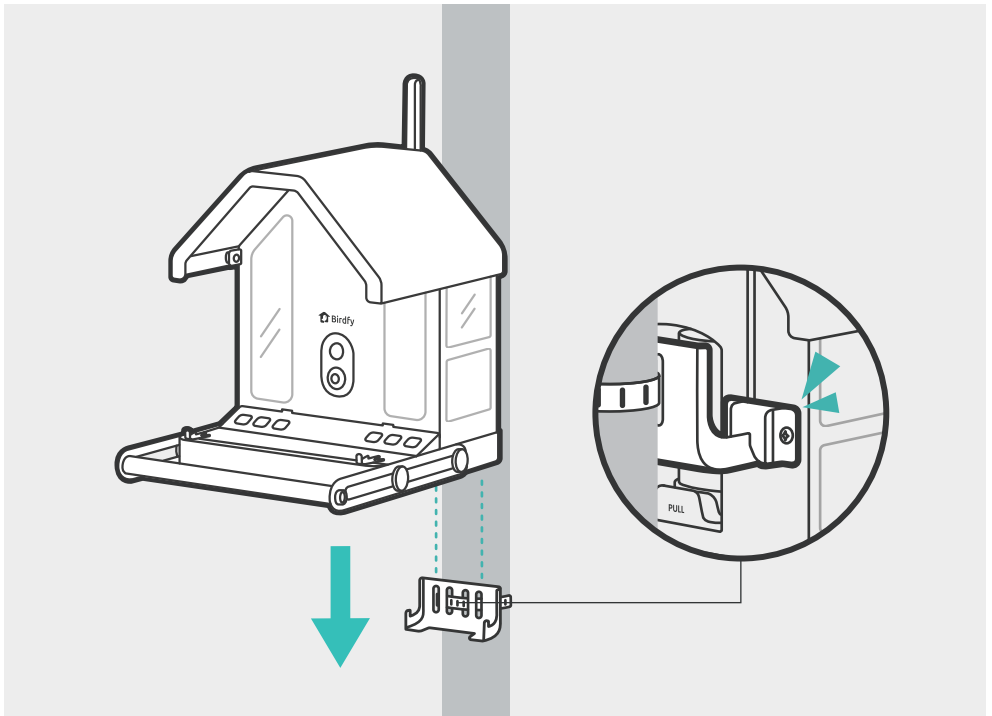

\*Before installation, choose the correct hose clip size for your pole from the accessories box.

\*Antes de la instalación, elige el tamaño adecuado de abrazadera para tu poste desde la caja de accesorios.

\*Avant l'installation, choisissez la bonne taille de collier de serrage pour votre poteau dans la boîte d'accessoires.

## B. Pole-top mount



Pole-top adapter  
Adaptador superior para poste  
Adaptateur pour poteau

- 1** Take the pole-top adapter out of the box and screw it into the pole mounting port at the bottom of the feeder.  
Saca el adaptador para la parte superior del poste de la caja y enróscalo en el puerto de montaje del poste en la parte inferior del comedero.  
Sortez l'adaptateur pour poteau de la boîte et vissez-le dans l'orifice de montage du poteau situé sous le distributeur.

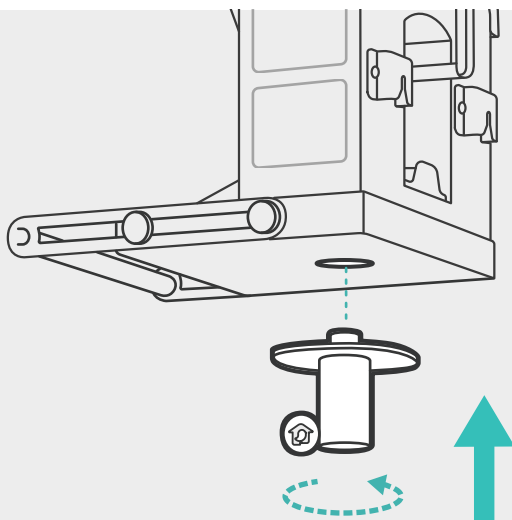

**2**

Depending on the pole's diameter, rotate the hand-tightening nut to secure the feeder firmly on top of the pole.

Dependiendo del diámetro del poste, gira la tuerca de apriete manual para fijar el comedero firmemente en la parte superior del poste.

Selon le diamètre du poteau, tournez l'écrou de serrage à la main pour fixer solidement le distributeur sur le dessus du poteau.

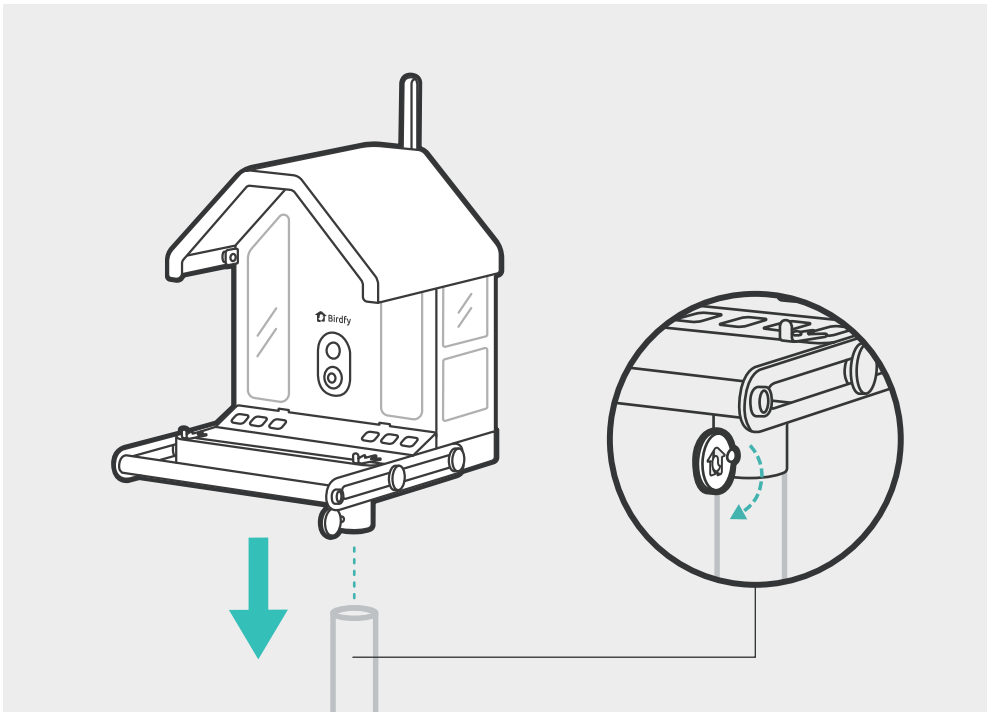

## C. Tree-mount



Black strap  
Correa negra  
Sangle noire

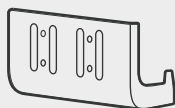

Hanging bracket  
Soporte colgante  
Support mural

- 1 Slide the strap through the bracket slots.

Deslice la correa a través de las ranuras del soporte.  
Faites glisser la sangle à travers les fentes du support.

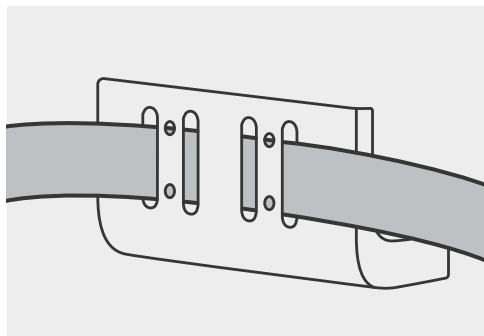

- 2 Wrap the strap around the tree.

Envuelva la correa alrededor del árbol.  
Enroulez la sangle autour de l'arbre.

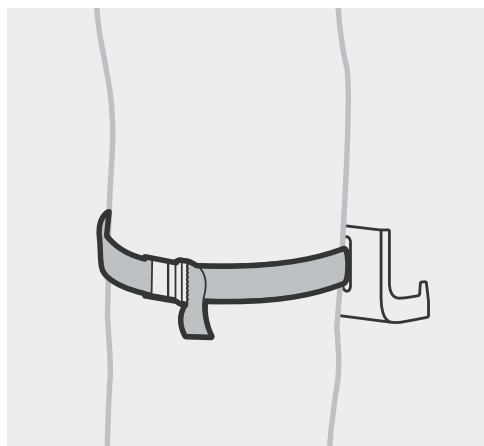

- 3** Hang the feeder on the tree.  
 Cuelgue el comedero en el árbol.  
 Accrochez la mangeoire sur l'arbre.

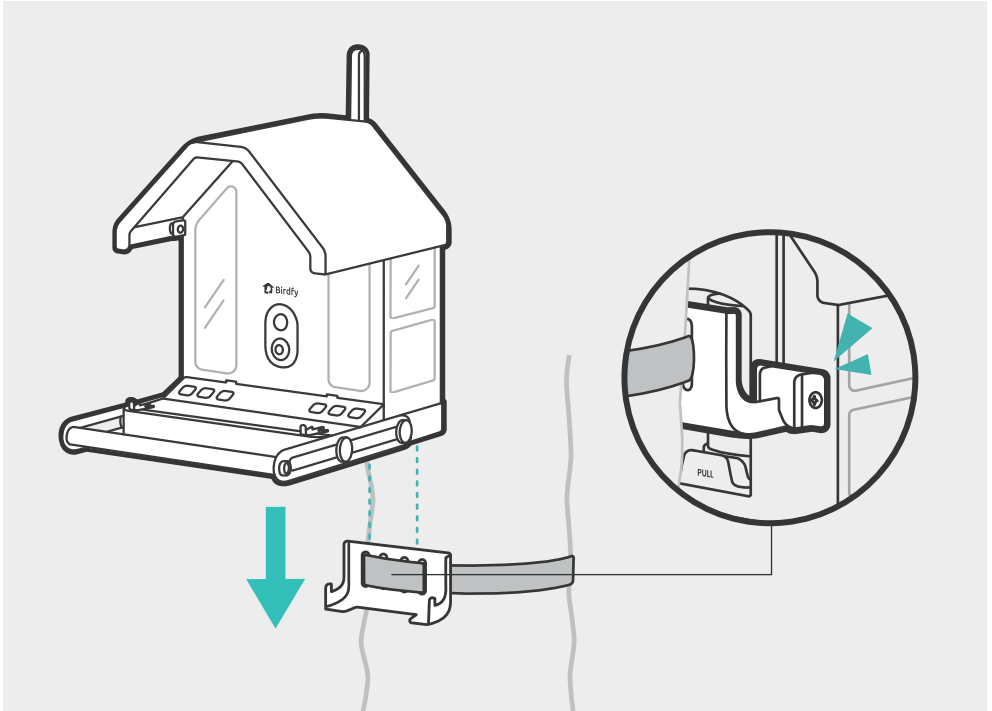

## D. Wall-mount

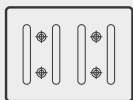

Drilling template  
Plantilla de perforación  
Gabarit de perçage



Anchors  
Tacos  
Chevilles

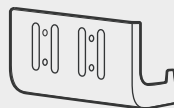

Hanging bracket  
Soporte colgante  
Support mural



Screws for mounting on wood  
Tornillos para montaje en madera  
Vis pour fixation sur bois



Screws for mounting on concrete  
Tornillos para montaje en hormigón  
Vis pour montage sur béton

1

Use the drill template and an electric drill (15/64", 6mm) to drill four holes.

Usa la plantilla de perforación y un taladro eléctrico (15/64", 6mm) para perforar dos agujeros.

Utilisez le gabarit de perçage et une perceuse électrique (15/64", 6 mm) pour percer deux trous.

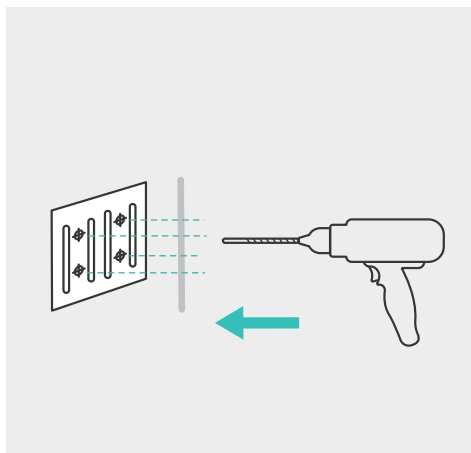

- 2** Insert the provided plastic anchors into the holes. (Note: Anchors are unnecessary when mounting on a wood surface.)

Inserta los tacos de plástico en los agujeros. (No se necesitan si se monta sobre madera).

Insérez les chevilles en plastique fournies dans les trous. (Pas besoin de chevilles pour une surface en bois.)

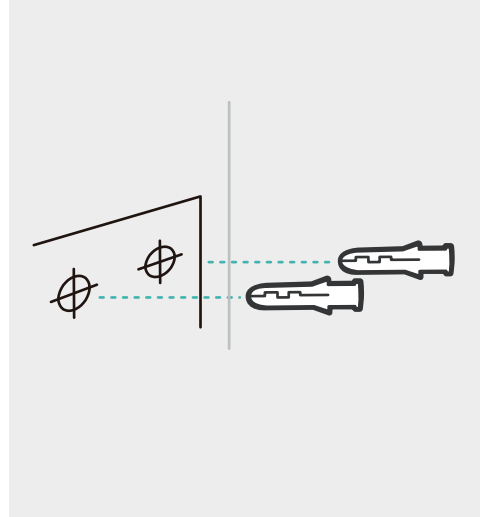

- 3** Based on the surface material, select appropriate screws and fasten the hanging bracket to the wall.

Según el material de la superficie, selecciona los tornillos adecuados y fija el soporte a la pared.

Selon le matériau de la surface, choisissez les vis appropriées et fixez le support mural.

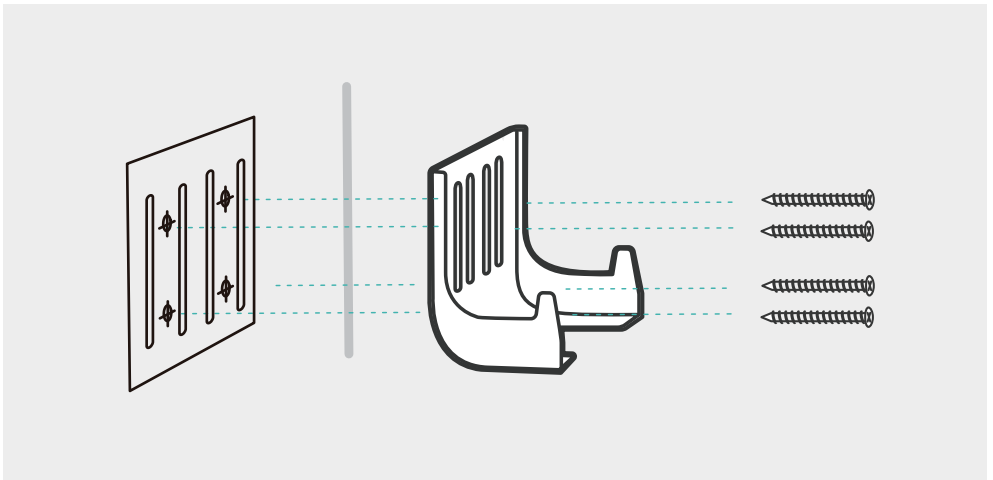

## INSTALLATION AND USE

- 4** Hang the feeder on the wall.  
Cuelga el comedero en la pared.  
Accrochez la mangeoire au mur.

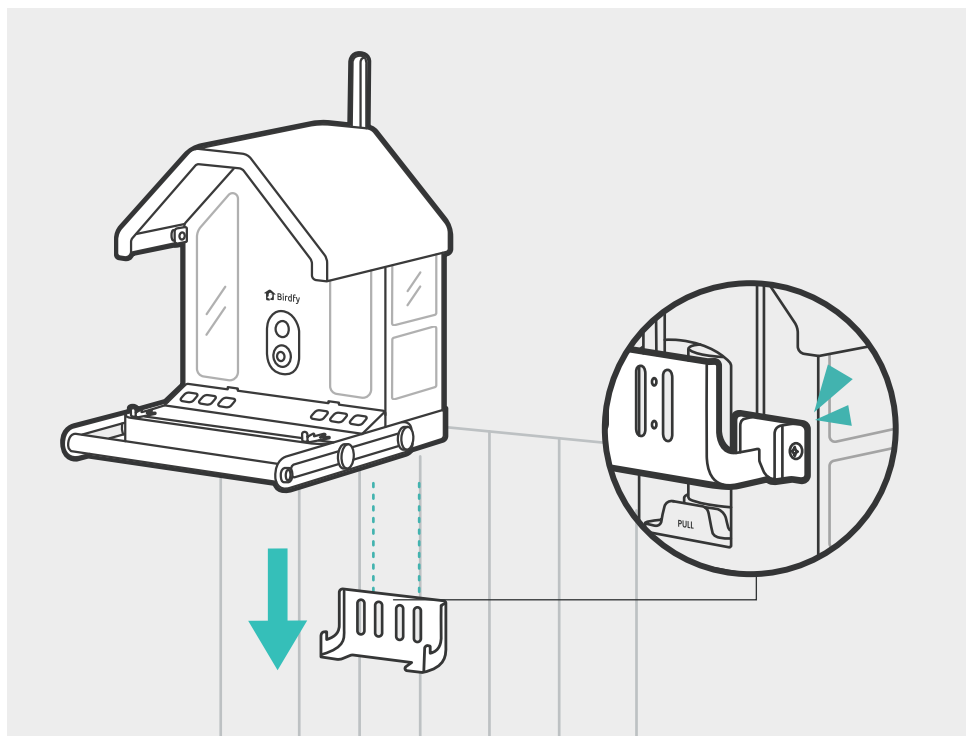

## Step 5: Add Birdseed

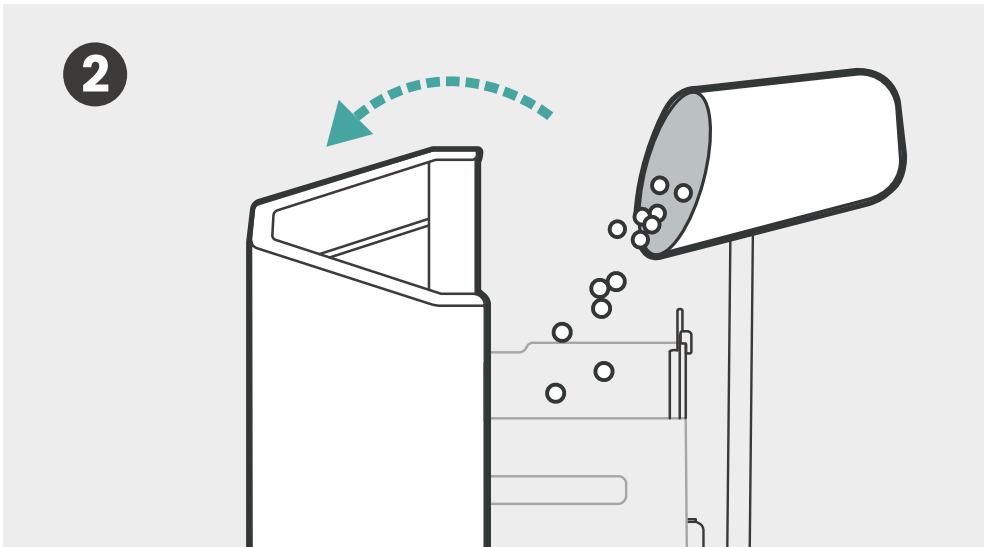
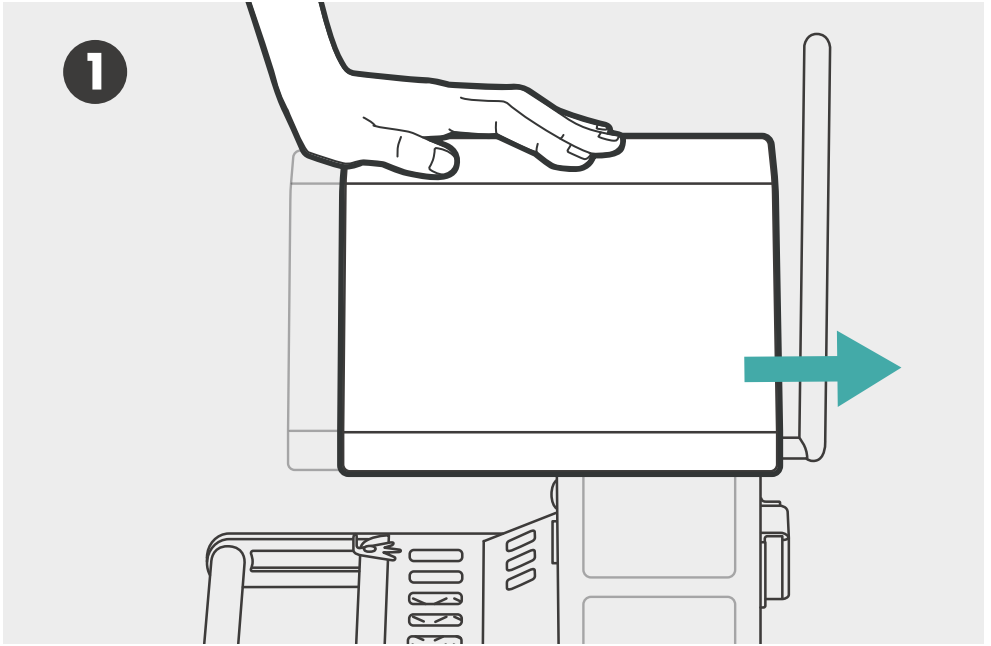

## Step 6: Adjust the Perch

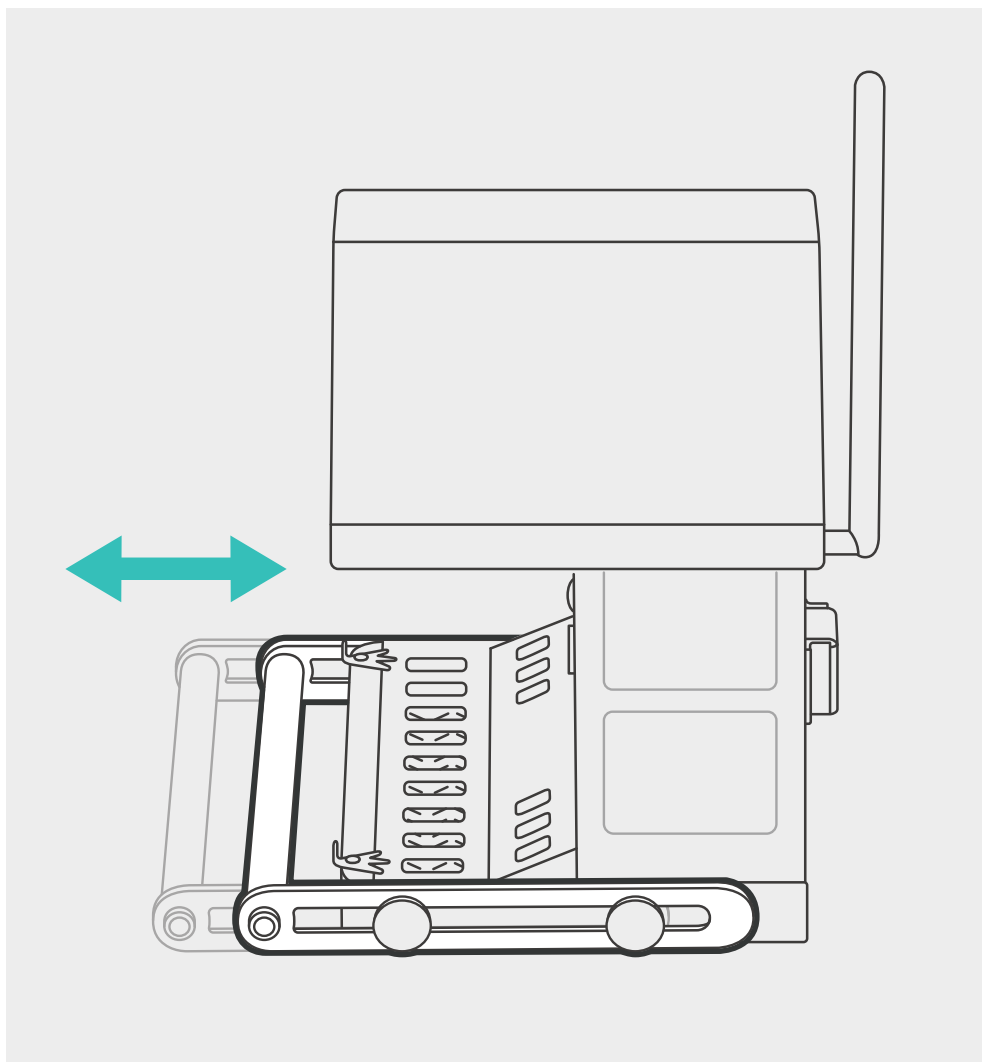

Extend the perch to the desired length.

Extiende el posadero hasta la longitud deseada.

Déployez le perchoir à la longueur souhaitée.

# Cleaning

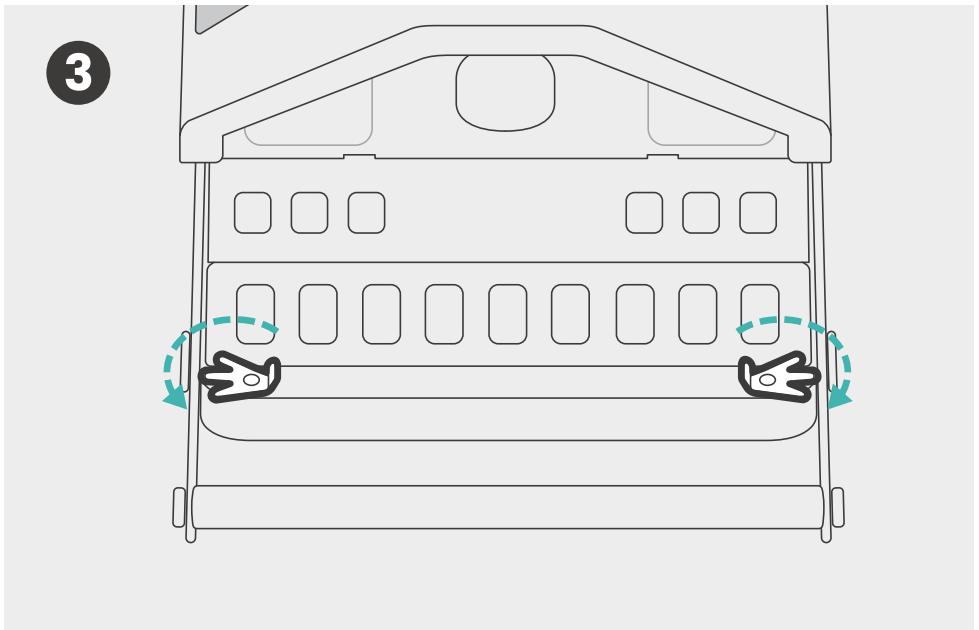
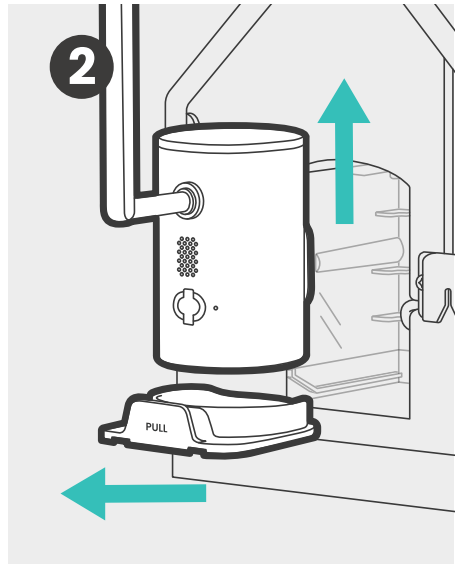
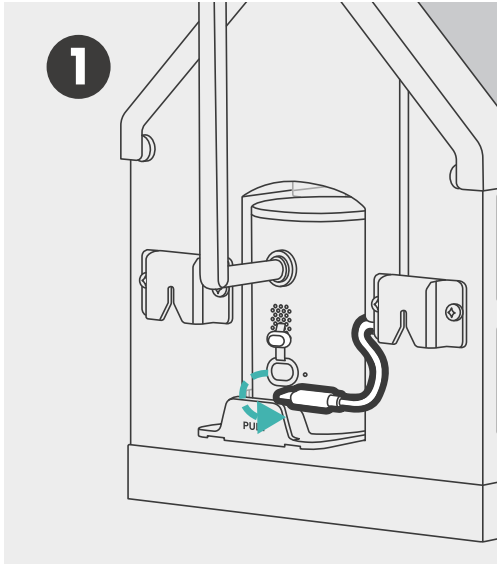

## MAINTENANCE

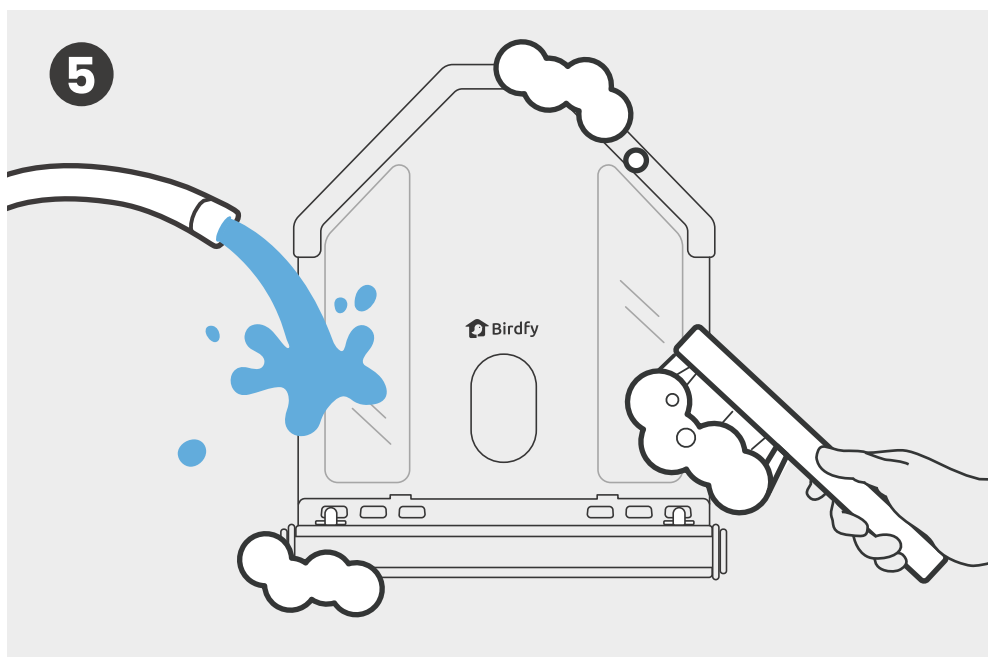
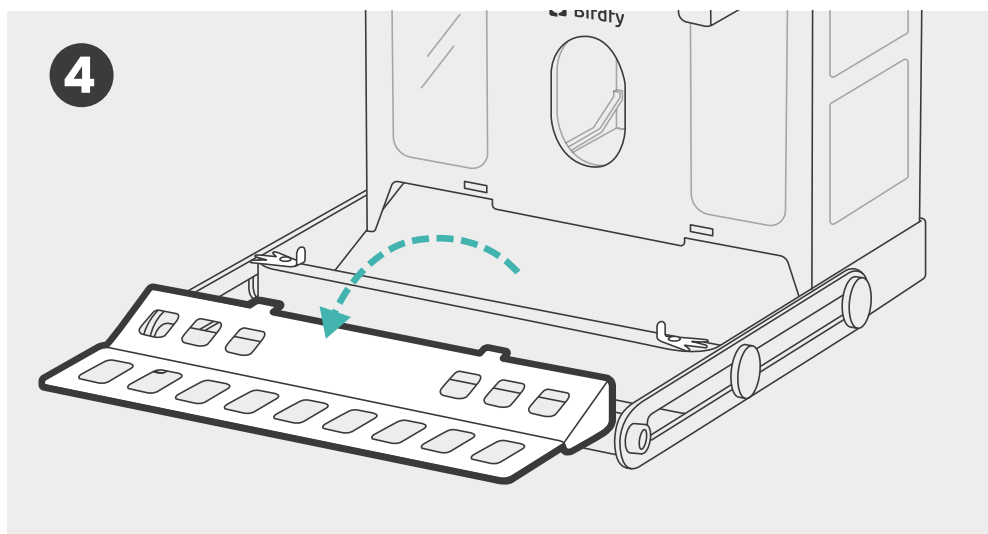

\*Please ensure the protective cap is covered while cleaning.

\*Asegúrate de mantener la tapa protectora puesta durante la limpieza.

\*Assurez-vous que le capuchon de protection est en place pendant le nettoyage.

# Support

If your Birdfy camera **goes offline or fails to stream**, try these troubleshooting steps:

- 1. Ensure the camera is fully charged.**
- 2. Verify your home Wi-Fi connectivity. Try to reconnect the camera to your Wi-Fi network.**

If the issue persists:

- 1. Disconnect the camera from the solar panel or charger.**
- 2. Slide the power switch OFF, then ON again to restart the camera.**

**Need help? Contact us for any questions or issues:**

 support@birdfy.com (Global)

 In-App Chat (Global)

 1(866)749-0567 (US Only)

Si tu cámara Birdfy **se desconecta o no transmite video**, prueba estos pasos para solucionar el problema:

- 1. Asegúrate de que la cámara esté completamente cargada.**
- 2. Verifica la conexión Wi-Fi de tu hogar. Intenta reconectar la cámara a tu red Wi-Fi.**

Si el problema persiste:

- 1. Desconecta la cámara del panel solar o del cargador.**
- 2. Desliza el interruptor de encendido a OFF y luego a ON nuevamente para reiniciar la cámara.**

**¿Necesitas ayuda? Contáctanos si tienes preguntas o algún problema:**

 support@birdfy.com (Global)

 Chat en la aplicación (Global)

 1(866)749-0567 (solo EE. UU.)

Si votre caméra Birdfy **se déconnecte ou n'arrive pas à diffuser**, essayez ces étapes de dépannage :

- 1. Assurez-vous que la caméra est complètement chargée.**
- 2. Vérifiez la connexion Wi-Fi de votre domicile. Essayez de reconnecter la caméra à votre réseau Wi-Fi.**

Si le problème persiste :

- 1. Débranchez la caméra du panneau solaire ou du chargeur.**
- 2. Faites glisser l'interrupteur d'alimentation sur OFF, puis sur ON pour redémarrer la caméra.**

**Besoin d'aide ? Contactez-nous pour toute question ou problème :**

-  [support@birdfy.com](mailto:support@birdfy.com) (Global)
-  Chat intégré à l'application (Global)
-  1(866)749-0567 (États-Unis uniquement)



**Birdfy Help Center**

# The Birdfy Community

Scan the QR code to join our vibrant Facebook community and connect with fellow bird enthusiasts! Discover valuable insights on birdwatching and bird feeding techniques, exchange your finest Birdfy captures, and witness exotic birds from around the world!

Escanee el código QR para unirse a nuestra vibrante comunidad de Facebook y conectarse con otros entusiastas de las aves. Descubra información valiosa sobre observación de aves y técnicas de alimentación, intercambie sus mejores capturas de Birdfy y observe aves exóticas de todo el mundo.

Scannez le code QR pour rejoindre notre communauté Facebook dynamique et vous connecter avec d'autres passionnés d'oiseaux! Découvrez des informations précieuses sur l'observation des oiseaux et les techniques d'alimentation, partagez vos meilleures captures Birdfy et contemplez des oiseaux exotiques du monde entier !



@birdfy by netvue

# Warning

## FCC Statement

Note: This equipment has been tested and found to comply with the limits for a Class B digital device, pursuant to part 15 of the FCC Rules. These limits are designed to provide reasonable protection against harmful interference in a residential installation. This equipment generates, uses and can radiate radio frequency energy and, if not installed and used in accordance with the instructions, may cause harmful interference to radio communications. However, there is no guarantee that interference will not occur in a particular installation. If this equipment does cause harmful interference to radio or television reception, which can be determined by turning the equipment off and on, the user is encouraged to try to correct the interference by one or more of the following measures:

- Reorient or relocate the receiving antenna.
- Increase the separation between the equipment and receiver.
- Connect the equipment into an outlet on a circuit different from that to which the receiver is connected.
- Consult the dealer or an experienced radio/TV technician for help.

This device complies with part 15 of the FCC Rules. Operation is subject to the following two conditions: (1) This device may not cause harmful interference, and (2) this device must accept any interference received, including interference that may cause undesired operation.

Any changes or modifications made without explicit approval from the responsible party in compliance may result in the user being unauthorized to operate the device.

This device meets the FCC radiation exposure limits for uncontrolled environments. To ensure safe installation and operation, maintain a minimum distance of 20cm between the radiator and your body.

FCC ID: 2BC96NB-CMA08

## IC Statement

This device contains licence-exempt transmitter(s)/receiver(s) that comply with Innovation, Science and Economic Development Canada's licence-exempt RSS(s). Operation is subject to the following two Economic Development Canada's licence-exempt RSS(s). Operation is subject to the following two conditions:

- (1) This device may not cause interference.
- (2) This device must accept any interference, including interference that may cause undesired operation of the device.

L'émetteur/récepteur exempt de licence contenu dans le présent appareil est conforme aux CNR d'Innovation, Sciences et Développement économique Canada applicables aux appareils radio exempts de licence. L'exploitation est autorisée aux deux conditions suivantes:

1. L'appareil ne doit pas produire de brouillage;
2. L'appareil doit accepter tout brouillage radioélectrique subi, même si le brouillage est susceptible d'en compromettre le fonctionnement.

This equipment complies with IC radiation exposure limits set forth for an uncontrolled environment. This transmitter must not be co-located or operating in conjunction with any other antenna or transmitter. This equipment should be installed and operated with a minimum distance of 20cm between the radiator and your body.

Cet équipement respecte les limites d'exposition au rayonnement IC établies pour un environnement non contrôlé.

Cet émetteur ne doit pas être localisé ou fonctionner en conjonction avec une autre antenne ou un autre émetteur. Cet équipement doit être installé et utilisé à une distance minimale de 20cm entre le radiateur et votre corps.

NETVUE INC.  
 1055 East Colorado Boulevard,  
 5th Floor, Pasadena, CA, 91106  
 +1(866)749-0567  
 support@birdfy.com

Icamera International Trading Co., Ltd  
 Unit G25 Waterfront Studios  
 1 Dock Road, London, United Kingdom  
 support@birdfy.com



eVatmaster Consulting GmbH  
 Raiffeisen Street 2B11, 63110,  
 Rodgau, Hessen, Germany  
 support@birdfy.com



- \*These addresses are not intended for returns. If you have any questions regarding returns or repairs, please contact us at **support@birdfy.com**.
- \*Estas direcciones no están destinadas para devoluciones. Si tienes alguna pregunta sobre devoluciones o reparaciones, contáctanos en **support@birdfy.com**.
- \*Ces adresses ne sont pas destinées aux retours. Si vous avez des questions concernant les retours ou les réparations, veuillez nous contacter à **support@birdfy.com**.

## WARNING



1. Contains batteries, keep away from fire.
  2. Battery withstandable use/storage/transport temperature: 14–113°F (-10–45°C).
  3. Replacing the battery with an incorrect type may cause a safety hazard.
  4. Disposing of battery in fire/oven, or crushing/cutting it, may cause explosion.
1. Contiene baterías, mantener alejado del fuego.
  2. Temperatura soportada por la batería para uso, almacenamiento o transporte: 14–113°F (-10–45°C).
  3. Reemplazar la batería con un tipo incorrecto puede representar un riesgo de seguridad.
  4. Desechar la batería en fuego/horno o aplastarla/cortarla puede causar una explosión.
1. Contient des piles, tenir à l'écart du feu.
  2. Température supportée par la batterie en utilisation, stockage ou transport : -10–45°C (14–113°F).
  3. Remplacer la batterie par un type incorrect peut présenter un danger pour la sécurité.
  4. Jeter la batterie au feu/au four ou l'écraser/la couper peut provoquer une explosion.



Brand: Birdfy  
Product Name: Birdfy Feeder Metal 2 4K  
Model: NB-FM004  
Camera Name: Birdfy Cam BA6A  
Camera model: NB-CMA08  
FCC ID: 2BC96NB-CMA08  
IC: 31482-NBCMA08  
HVIN: P66V1

Manufacturer: NETVUE INC.  
1055 East Colorado Boulevard 5th Floor,  
Pasadena, CA, 91106  
+1(866) 749-0567  
support@birdfy.com  
Made in China  
Designed in USA



## Contact us

---



support@birdfy.com  
(Global)



In-App Chat  
(Global)



1(866)749-0567  
(US Only)

[www.birdfy.com](http://www.birdfy.com)

© Netvue Inc.