

# 英文 规格: 420\*290MM

## PROSCAN

MODEL NO. PRCD243M

### PORTABLE CD BOOMBOX WITH AM/FM RADIO

#### INSTRUCTION MANUAL

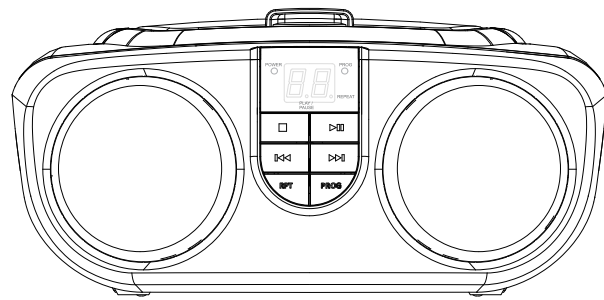

PLEASE READ BEFORE OPERATING THIS EQUIPMENT

PROSCAN and the PROSCAN logo are trademarks used under license by CURTIS INTERNATIONAL LTD. - www.proscan-brand.com.

#### Warnings and Precautions

TO PREVENT FIRE OR SHOCK HAZARDS, DO NOT EXPOSE THIS UNIT TO RAIN OR MOISTURE.



This symbol, located on back or bottom of the unit, is intended to alert the user to the presence of uninsulated "dangerous voltage" within the product's enclosure that may be of sufficient magnitude to constitute a risk of electric shock to persons.



This symbol, located on back or bottom of the unit, is intended to alert the user to the presence of important operating and maintenance (servicing) instructions in the literature accompanying the appliance.



This product utilizes a Class I laser to read Compact Discs. This laser Compact Disc Player is equipped with safety switches to avoid exposure when the CD door is open and the safety interlocks are defeated. Invisible laser radiation is present when the CD Player's lid is open and the system's interlock has failed or been defeated. It is very important that you avoid direct exposure to the laser beam at all times. Please do not attempt to defeat or bypass the safety switches.



This equipment is a Class II or double insulated electrical appliance. It has been designed in such a way that it does not require a safety connection to electrical earth.

**CAUTION: TO PREVENT ELECTRIC SHOCK, MATCH WIDE BLADE OF PLUG TO WIDE SLOT, FULLY INSERT.**

To reduce the risk of electric shock, do not remove cover (or back). There are no user-serviceable parts inside. Please refer any servicing to qualified service personnel.

**WARNING:** Changes or modifications to this unit not expressly approved by the party responsible for compliance could void the user's authority to operate the equipment.

Do not mix old and new batteries. Do not mix alkaline, standard (carbon-zinc), or rechargeable (ni-cad, ni-mh, etc) batteries.

NOTE: This equipment has been tested and found to comply with the limits for a Class B digital device, pursuant to Part 15 of the FCC Rules. These limits are designed to provide reasonable protection against harmful interference in a residential installation. This equipment generates, uses, and can radiate radio frequency energy and, if not installed and used in accordance with the instructions, may cause harmful interference to radio communications. However, there is no guarantee that interference will not occur in a particular installation. If this equipment does cause harmful interference to radio or television reception, which can be determined by turning the equipment off and on, the user is encouraged to try to correct the interference by one or more of the following measures:

- Reorient or relocate the receiving antenna.
- Increase the separation between the equipment and receiver.
- Connect the equipment into an outlet on a circuit different from that to which the receiver is connected.
- Consult the dealer or an experienced radio/TV technician for help.

2

#### Control Definitions

- 1. Stop Button**  
Press the Stop Button to stop a CD during play.
- 2. Program Button**  
Press the Program Button, in *CD mode*, to program up to 20 CD tracks.
- 3. Skip/Search Buttons**  
Press the Skip/Search Buttons to skip between CD tracks.  
Press and hold the Skip/Search Buttons to search through a single CD track.
- 4. Volume Dial**  
Turn the Volume Dial to adjust the volume of the unit.
- 5. Auxiliary Input**  
Use the Auxiliary Input to connect an external audio source (MP3 player) to the unit.
- 6. Play/Pause Button**  
Press the Play/Pause Button to play or pause a loaded CD.
- 7. Repeat Button**  
Press the Repeat Button once to repeat the current CD track.  
Press the Repeat Button twice to repeat the entire album.
- 8. Power Switch (CD, Off, FM, AM)**  
Adjust the Power Switch to select *CD, Off, FM, or AM mode*.
- 9. Tuning Dial**  
Turn the Tuning Dial to adjust the AM or FM radio station.
- 10. AC Power Input**  
Use the AC Power Input to connect the unit to an AC power source.

For service assistance and product information, please call: 1-800-968-9853.  
Pour obtenir assistance et information appelez: 1-800-968-9853.  
Curtis International Ltd. 7045 BECKETT DRIVE, UNIT 15, MISSISSAUGA, ON, L5S 2A3 www.curtisint.com

6

#### Important Safety Instructions

- 1. Read Instructions** - All the safety and operating instructions should be read before the product is operated.
  - 2. Retain Instructions** - The safety and operating instructions should be retained for future reference.
  - 3. Heat Warnings** - All warnings on the product and in the operating instructions should be adhered to.
  - 4. Follow Instructions** - All operating and use instructions should be followed.
  - 5. Cleaning** - Unplug this product from the wall outlet before cleaning. Do not use liquid cleaners or aerosol cleaners. Clean only with a dry cloth.
  - 6. Attachments** - Do not use attachments not recommended by the product manufacturer as they may cause hazards.
  - 7. Water and Moisture** - Do not use this product near water - for example, near a bath tub, wash basin, kitchen sink, or laundry tub, in a wet basement, or near a swimming pool, and the like. The apparatus shall not be exposed to dripping or splashing and that no objects filled with liquids, such as vases, shall be placed on apparatus.
  - 8. Accessories** - Do not place this product on an unstable cart, stand, tripod, bracket, or table. The product may fall, causing serious injury to a child or adult, and serious damage to the product. Use only with a cart, stand, tripod, bracket, or table recommended by the manufacturer or sold with the product. Any mounting of the product should follow the manufacturer's instructions, and should use a mounting accessory recommended by the manufacturer.
  - 9. A product and cart combination should be moved with care. Quick stops, excessive force, and uneven surfaces may cause the appliance and cart combination to overturn.**
- See figure:
- 
- 10. Ventilation** - Slots and openings in the cabinet are provided for ventilation and to ensure reliable operation of the product and to protect it from overheating, and these openings must not be blocked or covered. The openings should never be blocked by placing the product on a bed, sofa, rug, or other similar surface. This product should not be placed in a built-in installation such as a bookcase or rack unless proper ventilation is provided or the manufacturer's instructions have been adhered to.
  - 11. Power Sources** - This product should be operated only from the type of power source indicated on the marking label. If you are not sure of the type of power supply to your home, consult your product dealer or local power company. For products intended to operate from battery power, or other sources, refer to the operating instructions.
  - 12. Grounding or Polarization** - This product may be equipped with a polarized alternating-current line plug (a plug having one blade wider than the other). This plug will fit into the power outlet only one way. This is a safety
- feature: If you are unable to insert the plug fully into the outlet, try reversing the plug. If the plug should still fail to fit, contact your electrician to replace your obsolete outlet. Do not defeat the safety purpose of the polarized plug.
- Alternate Warnings** - This product is equipped with a three-wire grounding-type plug, a plug having a third (grounding) pin. This plug will only fit into a grounding-type power outlet. This is a safety feature. If you are unable to insert the plug into the outlet, contact your electrician to replace your obsolete outlet. Do not defeat the safety purpose of the grounding-type plug.
- 13. Power Cord Protection** - Power-supply cords should be routed so that they are not likely to be walked on or pinched by items placed upon or against them, paying particular attention to cords at plugs, convenience receptacles, and points where they exit from the product.
  - 14. Protective Attachment Plug** - The product is equipped with an attachment plug having overload protection. This is a safety feature. See Instruction Manual for replacement or resetting of protective device. If replacement of the plug is required, be sure the service technician has used a replacement plug specified by the manufacturer that has the same overload protection as the original plug.
  - 15. Outdoor Antenna Grounding** - If an outside antenna is connected to the receiver, be sure the antenna system is grounded so as to provide some protection against voltage surges and built-up static charges. Article 810 of the National Electrical Code, ANSI/NFPA 70, provides information with regard to proper grounding of the mast and supporting structure, grounding of the mast and supporting structure, grounding of the lead-in wire to an antenna-discharge unit, size of grounding conductors, location of antenna-discharge unit, and requirements for the grounding electrode.
  - 16. Lightning** - For added protection for this product during a lightning storm, or when it is left unattended and unused for long periods of time, unplug it from the wall outlet and disconnect the antenna or cable system. This will prevent damage to the product due to lightning and power-line surges.
  - 17. Power Lines** - An outside antenna system should not be located in the vicinity of overhead power lines or other electric light or power circuits, or where it can fall into such power lines or circuits. When installing an outside antenna system, extreme care should be taken to keep from touching such power lines or circuits as contact with them might be fatal.
  - 18. Overloading** - Do not overload wall outlets, extension cords, or integral convenience
- receptacles as this can result in a risk of fire or electric shock.
- 19. Object and Liquid Entry** - Never push objects of any kind into this product through openings as they may touch dangerous voltage points or short-out parts that could result in a fire or electric shock. Never spill liquid of any kind on the product.
  - 20. Servicing** - Do not attempt to service this product yourself as opening or removing covers may expose you to dangerous voltage or other hazards. Refer all servicing to qualified service personnel.
  - 21. Damage Reporting Service** - Unplug this product from the wall outlet and refer servicing to qualified service personnel under the following conditions:
    - a) When the power-supply cord or plug is damaged.
    - b) If liquid has been spilled, or objects have fallen into the product.
    - c) If the product has been exposed to rain or water.
    - d) If the product does not operate normally by following the operating instructions. Adjust only those controls that are covered by the operating instructions as an improper adjustment of other controls may result in damage and will often require extensive work by a qualified technician to restore the product to its normal operation.
    - e) If the product has been dropped or damaged in any way, and
    - f) When the product exhibits a distinct change in performance. This indicates a need for service.
  - 22. Replacement Parts** - When replacement parts are required, be sure the service technician has used replacement parts specified by the manufacturer or have the same characteristics as the original part. Unauthorized substitutions may result in fire, electric shock, or other hazards.
  - 23. Safety Check** - Upon completion of any service or repairs to this product, ask the service technician to perform safety checks to determine that the product is in proper operating condition.
  - 24. Wall or Ceiling Mounting** - The product should be mounted to a wall or ceiling only as recommended by the manufacturer.
  - 25. Heat** - The product should be situated away from heat sources such as radiators, heat registers, stoves, or other products (including amplifiers) that produce heat. Battery shall not be exposed to excessive heat such as sunshine, fire, or the like.
  - 26. Main plug** - If used as a disconnect device and it should remain readily operable during intended use. In order to disconnect the product from the mains completely, the main plug should be disconnected from the main socket outlet completely.
  - 27. Excessive sound pressure** from earphones and headphones can cause hearing loss.

3

#### Tuning the AM or FM Radio

- Step 1:** Adjust the Power Switch to *AM or FM mode*.
- *Both AM/FM antenna is built into the unit. Adjust the unit to improve reception.*
- Step 2:** Turn the Tuning Dial to the desired AM or FM station.
- Note:** This is analog tuning radio. The radio frequency is marked on the dial.

#### Playing a CD

- Step 1:** Open the CD door, and place a CD or CD-R/RW into the player.
- Step 2:** Adjust the Power Switch to *CD mode*.
- Step 3:** Press the Play/Pause Button to begin playing the loaded CD.

#### Programming a CD

- Step 1:** Open the CD door, and place a CD or CD-R/RW into the player.
- Step 2:** Adjust the Power Switch to *CD mode*.
- Step 3:** Press the Program Button.
- Step 4:** Press the Skip/Search Buttons to select the CD track to play.
- Step 5:** Press the Program Button.
- Step 6:** Repeat Steps 4-5 to program up to 20 total CD tracks.

#### Using the Auxiliary Input

Audio Source	Required Connector
MP3 Player	mini-phonos 3.5mm Cable (not included)

- Step 1:** Connect a *mini-phonos 3.5mm Cable* (not included) to the **Auxiliary Input** on the unit and the audio output on an MP3 player.
- Step 2:** Adjust the Power Switch to *CD mode*.
- *Audio played through the connected MP3 player will now be heard through the unit.*

#### Specifications

Power Output	1.2 watt RMS x 2 channels
AC Power	AC120V~60Hz
Battery Size	UM-2 or C-Size batteries x 6 PCS
Radio Frequency	FM: 87.5 - 108MHz, AM: 520- 1710 kHz
Audio Frequency Range (Hz)	80Hz -18KHz

7

#### Features

- CD player: CD, CD-R/RW\*
- AM/FM radio
- Auxiliary input
- Programmable CD tracks
- 2-digit red LED
- Built-in speakers
- AC power: detachable AC cord
- DC power: requires 6 C batteries, not included

\*MP3 or other non-CD format disc is not compatible

#### Powering the Unit

##### AC Power

Plug the detachable AC cord into a standard AC outlet (120V~60Hz)

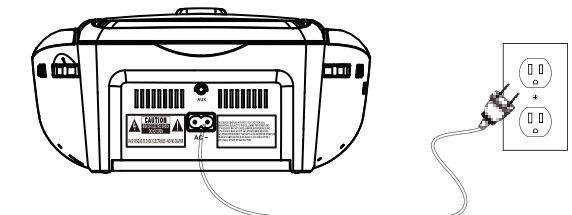

##### Battery Power

Requires 6 C batteries, not included.

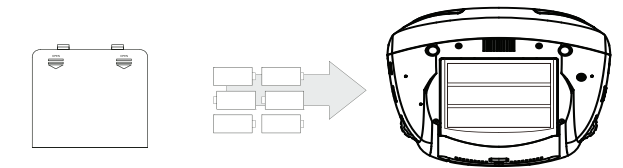

4

To make a warranty claim, please email [support@curtiscs.com](mailto:support@curtiscs.com) or call 1-800-968-9853.

#### 90 day Warranty

This product is warranted to be free from defects in material and workmanship for a period of ninety (90) days from the date of original purchase. During this period, your exclusive remedy is repair or replacement of this product or component found to be defective, at our option; however, you are responsible for all costs associated with returning the product to us. If the product or component is no longer available, we will replace with a similar one of equal or greater value. Prior to a replacement being sent, the product must be rendered inoperable or returned to us.

This warranty does **not** cover glass, filters, wear from normal use, use not in conformity with the printed directions, or damage to the product resulting from accident, alteration, abuse, or misuse. This warranty extends only to the original consumer purchaser or gift recipient. Keep the original sales receipt, as proof of purchase is required to make a warranty claim. This warranty is void if the product is used for other than single-family household use or subjected to any voltage and waveform other than as on the specified rating on the label (e.g., 120V~60Hz).

We exclude all claims for special, incidental, and consequential damages caused by breach of express or implied warranty. All liability is limited to the amount of the purchase price. **Every implied warranty, including any statutory warranty or condition of merchantability or fitness for a particular purpose, is disclaimed except to the extent prohibited by law, in which case such warranty or condition is limited to the duration of this written warranty.** This warranty gives you specific legal rights. You may have other legal rights that vary depending on where you live. Some states or provinces do not allow limitations on implied warranties or special, incidental, or consequential damages, so the foregoing limitations may not apply to you.

For faster service, locate the model, type, and serial numbers on your appliance.

ATTACH YOUR PROOF OF PURCHASE HERE, PROOF OF PURCHASE IS REQUIRED TO OBTAIN WARRANTY SERVICE.

Please have the following information available when you contact the Support Team:

- Name, address and telephone number.
- Model number and serial number.
- A clear, detailed description of the problem.
- Proof of purchase including dealer or retailer name, address and date of purchase.

5

