

Job Name:	
Submitted By:	



Submittal Sheet For:	UB048GMSILDFHG / YN048GMSI20RUG
-----------------------------	--

Date _____
 Ref. _____

Floor-Ceiling Mount Ductless 20SEER Inverter Heat Pump

System Full Set Model: **UYB048GMSI20RL**

AHRI Reference Number: **218010996**

Cooling Mode Performance

Rated Cooling	48,000 BTU/hr
Ambient Range	5~131°F
SEER2 Rating	19.9 BTU/W·h
EER2 Rating	9.5 BTU/W·h

* 100% Capacity @ Indoor DB 80°F / WB 67°F

Heating Mode Performance

Rated Heating	50,000 BTU/hr
Ambient Range	-13~86°F
HSPF2 IV (V)	12.0 (7.8) BTU/W·h
COP2 (47°F)	2.82 W/W

Heating (17°F) = 45,100 BTU / Heating (5°F) = 38,500 BTU / COP2 (5°F) = 1.95 W/W



Floor-Ceiling Mount Indoor Unit



Outdoor Condensing Unit



User-Selected Installation Kit



Handheld Remote Controller

Electrical Information

	Cooling	Heating
Rated Input (W)	5,055	5,195
Rated Current (A)	22.0	22.6
Breaker Needed	45A (Double-Pole)	
Power Supply	208~230V, 60Hz, 1Ph	

Piping and Refrigerant

Liquid Line (OD)	3/8 in
Suction Line (OD)	3/4 in
Refrigerant Precharge	R-454b(Supports 10-50 ft.)
Max Length/Height Diff.	250 ft. / 100 ft.

This combination is AHRI/ETL/ISO certified.



Interior Unit (Air Handler) Specifications

Type	Heat Pump
Sound Level (dBA)	55(Turbo)/53(Hi)/49(Med)/39(Lo)/34(Mute)
Auto Air Circulation	Upright (Floor) / Horizontal (Ceiling)
Dimensions (WDH)	65 in x 26-5/8 in x 9-1/4 in
Weight (lbs)	89

Exterior Unit (Condenser) Specifications

Sound Level (dBA)	64
Recommended Room Size	1,400~1,800 Sq. ft.
Minimum Room Size	143 (Ceiling Suspended)/700 (Floor/Low Wall)
Compressor	Inverter-Driven Rotary
Dimensions (WDH)	37-1/2 in x 16-3/8 in x 52-1/2 in
Weight (lbs)	208.8

UB048GMSILDFHG Air Handler Dimensional Data

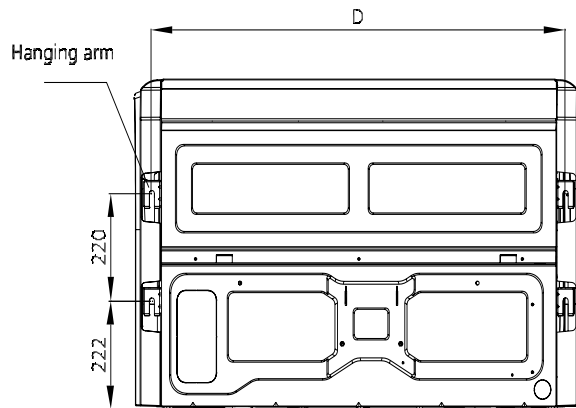
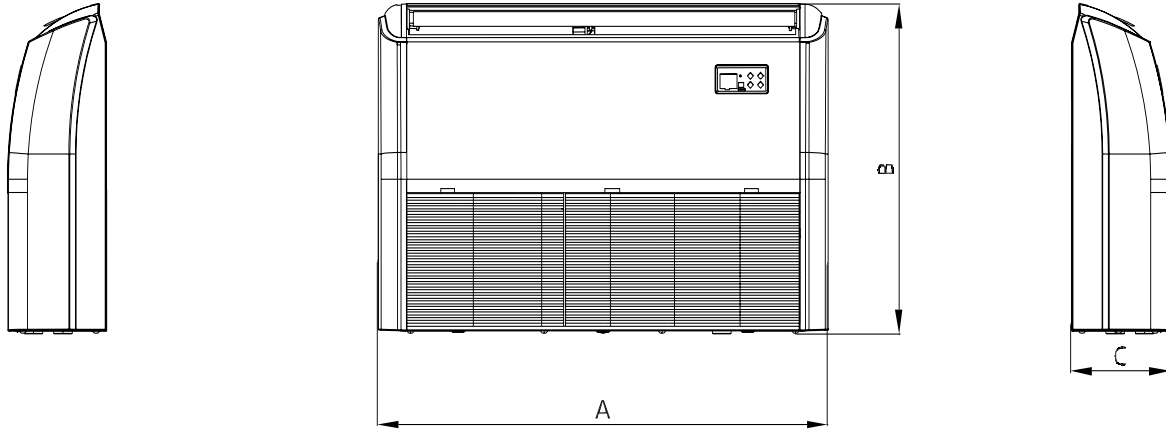
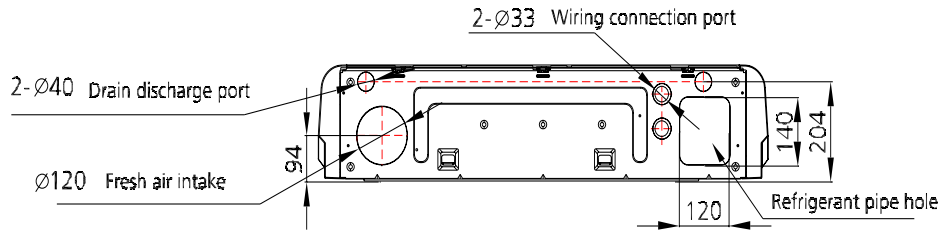

Model (KBtu/h)	Unit	A	B	C	D
36-48	mm	1650	675	235	1565
	inch	64.96	26.57	9.25	61.61

FRONT VIEW

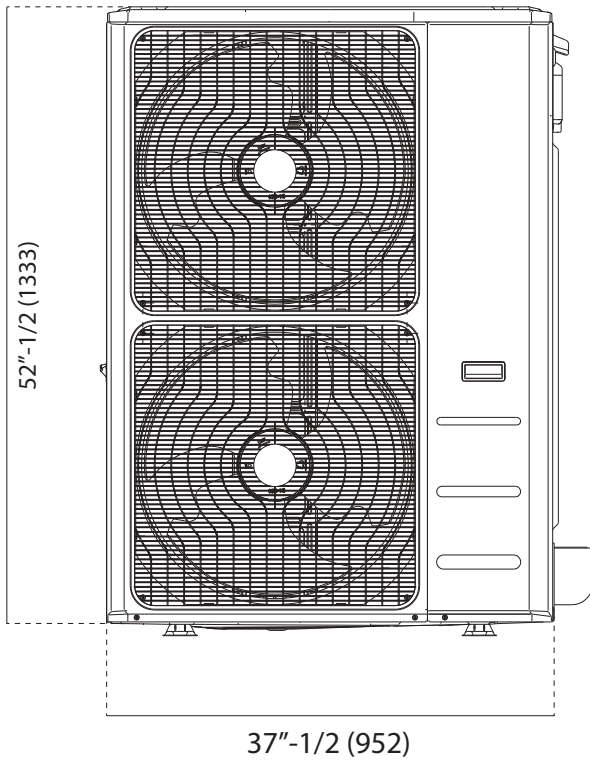

SIDE VIEW

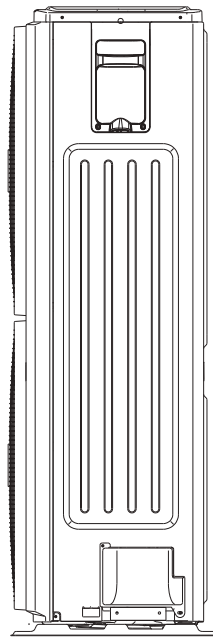

TOP VIEW

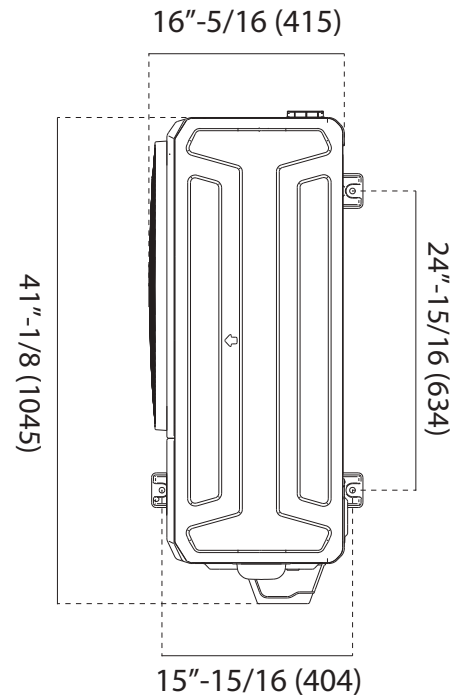

All dimensions are in Inches (mm)

Warranty Information and Length



Complete warranty details are available with the vendor or online at <https://www.pdhvac.com/support/warranty/>. This high quality system is eligible for up to 10 years limited warranty on the compressor, and 7 years on other internal parts. To qualify for this warranty, the system must be installed within 90 days by a registered technician. All other installations that are registered default to 5 years parts/compressor. Products unregistered qualify for only 1 year parts/compressor warranty.

Outstanding Features

- LED Display
- Energy Saving
- Ultra-Thin Design
- Dual Drain Options
- Customizable Timer
- Eco-Friendly Refrigerant
- Whisper-Quiet Operation
- Power Loss Memory Recovery



Available Accessories

Part Number	Description
IKT-LCVR4P-KIT	Decorative PVC Line Cover Kit
IKT-LNBR-1/4-3/8	BendAid Flexible Easy Bender Kit
BRK-FRM-C-2P	Folding Mounting Bracket w/ Leveler
IKT-UVL32UL-AG	UVC Bacterial Disinfection Kit
IKT-SURPRK-DV2	Ultimate Surge and Power Protection