

**DYNE X**™ ●●●

32" LCD TV

**DX-32E150A11**

**USER GUIDE**

# Dynex DX-32E150A11

## 32" LCD TV

### Contents

Important safety instructions .....	2
Warnings .....	2
Cautions .....	2
Package contents .....	3
Installing and removing the stand .....	3
Installing the stand .....	3
Installing a wall-mount bracket .....	4
TV components .....	4
Front .....	4
Back .....	5
Remote control .....	5
Using the remote control .....	6
Installing remote control batteries .....	6
Aiming the remote control .....	6
Programming a universal remote control to work with your TV .....	7
Making connections .....	7
Selecting a location .....	7
Connecting the power .....	7
Connecting an HDMI device (best) .....	8
Connecting a component video device (better) .....	8
Connecting an antenna, cable TV, or satellite TV box .....	8
Connecting a VCR, camcorder, or game (good) .....	8
Connecting a computer .....	9
Connecting headphones .....	9
Connecting a digital audio amplifier .....	10
Turning on your TV for the first time .....	10
Understanding the basics .....	11
Turning your TV on or off .....	11
Selecting the video input source .....	11
Selecting a channel .....	11
Adjusting the volume .....	11
Displaying additional information .....	11
On-screen menu overview .....	11
Navigating the menus .....	12
Adjusting basic settings .....	12
Adjusting the picture .....	13
Adjusting the TV picture .....	13
Adjusting the computer image .....	13
Adjusting the sound .....	14
Adjusting sound settings .....	14
Playing TV audio only .....	14
Changing channel settings .....	15
Automatically scanning for channels .....	15
Hiding channels .....	15
Setting up a favorite channel list .....	16
Adding or changing a channel label .....	16
Fitting the picture to the screen .....	17

Checking the DTV signal strength .....	17
Setting parental controls .....	17
Turning parental controls on or off .....	17
Setting or changing the password .....	18
Turning button lock on or off .....	19
Setting parental control levels .....	19
Adjusting time settings .....	21
Setting the date and time .....	21
Setting the sleep timer .....	22
Using closed captioning .....	22
Selecting the closed captioning mode .....	22
Selecting the closed captioning type .....	23
Customizing digital TV closed captioning styles .....	23
Adjusting menu settings .....	24
Selecting the menu language .....	24
Labeling an input source .....	24
Restoring default settings .....	25
Troubleshooting .....	25
Video and audio .....	25
Remote control .....	26
General .....	26
Maintenance .....	26
Cleaning .....	26
Specifications .....	26
Legal notices .....	27
One-year limited warranty .....	29
US and Canada Markets .....	29
Mexico Market .....	29



# CHILD SAFETY

**It makes a difference how and where you use your flat panel display**

**As you enjoy your new product, keep these safety tips in mind**

## *The issue*

The home theater entertainment experience is a growing trend, and larger TVs are popular purchases. However, TVs are not always supported on the proper stands or installed according to the manufacturer's recommendations. We and the consumer electronics industry are committed to making home entertainment enjoyable and safe.

TVs that are inappropriately placed on dressers, bookcases, shelves, desks, speakers, chests, or carts may fall over and cause injury.

## *Tune into safety*

- One size of TV stand does not fit all. Use only a TV stand rated for the weight of your TV.
- Carefully read and understand all enclosed instructions for proper use of this product.
- Don't let children climb on or play with entertainment system furniture and TVs.
- Don't place TVs on furniture that can easily be used as steps, such as a chest of drawers.
- Remember that children can become excited while watching a program, especially on a "larger-than-life" TV. Make sure that you place or install the TV where it cannot be pushed, pulled over, or knocked down.
- Make sure that you route all cords and cables so that they cannot be pulled or grabbed by curious children.



## *Wall mounting*

*Important: This TV is intended to be supported by a UL listed Wall Mount Bracket, marked with the minimum loading weight of 20.7 lb. (9.4 kg).*

If you decide to wall mount your TV, always:

- Use only a wall mount rated for the weight of your TV and that has been recommended by this TV manufacturer, listed in this manual, or otherwise listed by an independent laboratory as suitable for your TV. One size of wall mount does not fit all.
- Follow all instructions supplied by the TV and wall mount manufacturers.
- If you have any doubts about your ability to safely wall mount your TV, get help from a professional installer.
- Make sure that the wall where you are mounting the TV is appropriate. Some wall mounts are not designed to be mounted to walls backed with steel studs or cinder blocks. If you are unsure, ask a professional installer.
- TVs can be heavy. At least two people are required for safe wall mount installation.



## Important safety instructions



This symbol indicates that dangerous voltage constituting a risk of electric shock is present within your TV. This label is located on the back of your TV.



This symbol indicates that there are important operating and maintenance instructions in the literature accompanying your TV.

- 1 Read these instructions.
- 2 Keep these instructions.
- 3 Heed all warnings.
- 4 Follow all instructions.
- 5 Do not use this apparatus near water.
- 6 Clean only with a dry cloth.
- 7 Do not block any ventilation openings. Install in accordance with the manufacturer's instructions.
- 8 Do not install near any heat sources such as radiators, heat registers, stoves, or other apparatus (including amplifiers) that produce heat.
- 9 Do not defeat the safety purpose of the polarized or grounding-type plug. A polarized plug has two blades with one wider than the other. A grounding type plug has two blades and a third grounding prong. The wide blade or the third prong are provided for your safety. If the provided plug does not fit into your outlet, consult an electrician for replacement of the obsolete outlet.
- 10 Protect the power cord from being walked on or pinched particularly at plugs, convenience receptacles, and the point where they exit from the apparatus.
- 11 Only use attachments/accessories specified by the manufacturer.
- 12 Use only with a cart, stand, tripod, bracket, or table specified by the manufacturer, or sold with the apparatus. When a cart is used, use caution when moving the cart/apparatus combination to avoid injury from tip-over. 
- 13 Unplug this apparatus during lightning storms or when unused for long periods of time.
- 14 Refer all servicing to qualified service personnel. Servicing is required when the apparatus has been damaged in any way, such as power-supply cord or plug is damaged, liquid has been spilled or objects have fallen into the apparatus, the apparatus has been exposed to rain or moisture, does not operate normally, or has been dropped.
- 15 The *mains plug* is the disconnecting device. The plug must remain readily operable.
- 16 The apparatus with grounding-type plug is a class I apparatus. Class I apparatus need to be connected to earth ground wire to prevent possible electric shock. Make sure that you connect the class I apparatus to a mains socket outlet with a protective grounded connection.
- 17 Remote control batteries should not be exposed to excessive heat such as sunshine, fire, or the like.

- 18 The apparatus shall not be exposed to dripping or splashing, and no objects filled with liquids, such as vases, shall be placed on the apparatus.

## Warnings

### Electric shock hazard

To reduce the risk of fire or electric shock, do not remove any cover or expose the device to rain or moisture. No user-serviceable parts are inside. Refer servicing to qualified service technicians.

### Lightning

For added protection for your TV during a lightning storm, or when it is left unattended and unused for long periods of time, unplug it from the power outlet and disconnect any antenna or cable system. This helps prevent property damage and personal injury from lightning and power line surges.

### Power lines

An outside antenna system should not be located in the vicinity of overhead power lines or other electric light or power circuits, or where it can fall into such power lines or circuits. When installing an outside antenna system, extreme care should be taken to keep from touching such power lines or circuits as contact with them might be fatal.

### Handling the LCD panel

- Your TV's screen is made of glass. Do not drop your TV or hit, jolt, or press hard against the LCD panel. If the screen breaks, be careful of broken glass.
- If the LCD panel is broken, make absolutely sure that you do not touch the liquid in the panel. This may cause skin inflammation.
- If the liquid gets in your mouth, immediately gargle, rinse, and consult with your doctor. Also, if the liquid gets in your eyes or touches your skin, consult with your doctor after rinsing for at least 15 minutes or longer in clean water.

### Replacement parts

When replacement parts are required, make sure that the service technician uses replacement parts specified by the manufacturer that have the same characteristics as the original part. Unauthorized substitutions may result in fire, electric shock, personal injury, or other hazards.

### Safety check

After completing any service or repair to this device, ask the service technician to perform routine safety checks to determine that your TV is in correct operating condition.

### Power source

Operate your TV only from the type of power source indicated on the marking label. If you are not sure of the type of power supplied to your home, consult an electrician or your local power company.

## Cautions

### Damage requiring service

Unplug this TV from the power outlet and refer servicing to qualified service personnel under the following conditions:

- When the power supply cord or plug is damaged or frayed.
- If liquid has been spilled or objects have fallen into your TV.
- If your TV has been exposed to rain or water.

- If your TV does not operate normally by following the operating instructions. Adjust only those controls that are covered by the operating instructions because incorrect adjustment of other controls may result in damage and will often require extensive work by a qualified technician to restore your TV to its normal operation.
- If your TV has been dropped or damaged in any way.
- When your TV exhibits a distinct change in performance.

### Outdoor antenna grounding

If an outside antenna or cable system is connected to your TV, make sure that the antenna or cable system is grounded to provide some protection against voltage surges and built-up static charges. Article 810 of the National Electrical Code, ANSI/NFPA No. 70, provides information with respect to correct grounding of the mast and supporting structure, grounding of the lead-in wire to an antenna discharge unit, size of grounding conductors, location of the antenna-discharge unit, connection to grounding electrodes, and requirements for the grounding electrode.

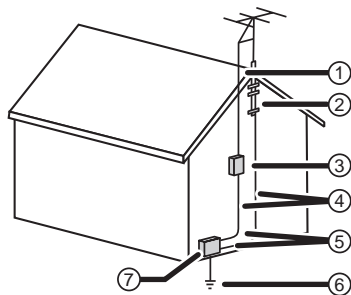

- ① Antenna lead-in wire
- ② Grounding clamp
- ③ Antenna discharge unit
- ④ Grounding conductors
- ⑤ Ground clamps
- ⑥ Power service grounding electrode system
- ⑦ Electric service equipment

### Note to CATV system installer

Article 820 of the National Electrical Code, ANSI/NFPA No. 40 provides guidance for correct grounding. Specifically, it states that the cable ground must be connected to the grounding system of the building as close to the point of cable entry as practical.

### Condensation

Moisture will form on the TV if the TV is brought from cool surroundings into a warm room or if the temperature of the room rises suddenly. When this happens, the TV's performance may be impaired. To prevent this, let the TV stand in its new surroundings for about an hour before switching it on, or make sure that the room temperature rises gradually. Condensation may also form during the summer if the TV is exposed to the breeze from an air conditioner. In such cases, change the location of the TV.

### Mobile telephone warning

To avoid interference with your TV picture and sound, operating problems, or even damage, keep your cordless and cellular telephones away from the TV.

### End of life directives

Your TV contains tin-lead solder and a fluorescent lamp containing a small amount of mercury. Disposal of these materials may be regulated for environmental reasons. Your TV also contains material that can be recycled and reused. For disposal or recycling information, contact your local authorities or the Electronic Industries Alliance at [www.eia.org](http://www.eia.org) to find a recycler in your area.

### Non-active pixels

The LCD panel contains almost 3 million thin film transistors, which provide exceptionally sharp video quality. Occasionally, a few non-active pixels may appear on the screen as a fixed blue, green, or red point. These non-active pixels do not adversely affect the performance of your TV, and are not considered defects.

## Package contents

Make sure the following items are included in the box with your TV:

- Remote control
- Composite video and audio cable
- AC power cord
- AAA batteries (2)
- Stand
- Stand column
- *Quick Setup Guide*
- Screws (8)

## Installing and removing the stand

You must install your TV into the stand for it to stand upright on a cabinet or other flat surface. If you intend to mount your TV on a wall or other vertical surface, you must remove the stand column.

**Warning:** Before attempting assembly or removal of the stand, unplug the AC power cord.

### Cautions:

Read these instructions thoroughly before attempting this installation.

Make sure that you handle your TV very carefully when attempting assembly or removal of the stand. If you are not sure of your ability to do this, or to use the tools necessary to complete this job, refer to a professional installer or service personnel. The manufacturer is not responsible for any damages or injuries that occur due to mishandling or improper assembly.

When using a table or bench as an aid to assembly, make sure that you place the TV on a soft cushion or covering to prevent accidental scratching or damage to your TV's finish.

## Installing the stand

### To install the stand:

- 1 Remove the stand, stand column, and screws from the box.
- 2 Align the holes in the stand with the holes in the stand column, then secure the stand to the stand column with the longer screws (M4) provided.

**Important:** The wider portion of the stand should go towards the front of the TV.

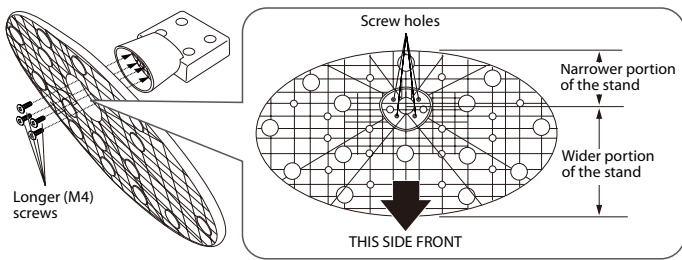

- 3 Lay a soft, dry, and lint-free cloth on a table and place the TV face down on the cloth. Insert the stand column into the TV and secure it with the four stand column screws (M6).

**Important:** The wide portion of the stand should go towards the front of the TV.

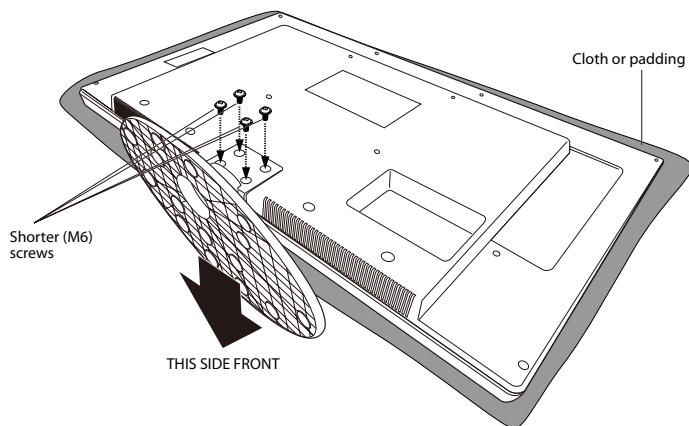

To remove the stand from the TV, perform these steps in reverse order.

## Installing a wall-mount bracket

If you want to attach the TV to a wall-mount bracket (not provided), you should first remove the stand pedestal if it is pre-attached.

### To remove the stand column:

- 1 Lay your TV face down on a table or bench. Make sure that you put down a soft cushion or cloth so that your TV is not scratched.
- 2 Remove the four screws holding the stand column to your TV, then remove the stand and the stand column.

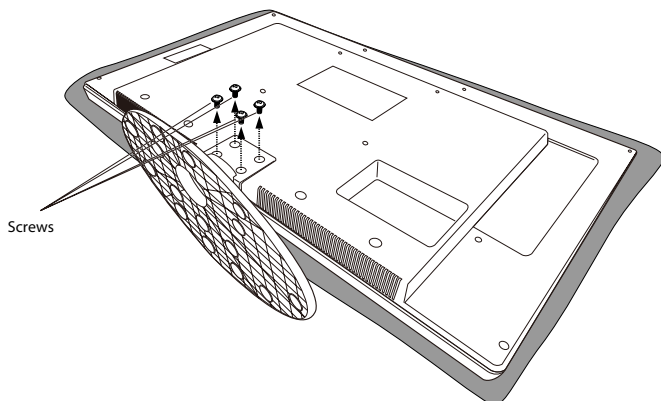

**Note:** The appearance of this product in these illustrations may differ from your actual product, and is for comparative purposes only.

### To attach your TV to a wall-mount bracket:

- 1 Remove the four screws holding the TV to its base, as previously described.
- 2 Secure the wall-mount bracket to the back of your TV using the four M6 screws provided with the bracket.

## TV components

### Front

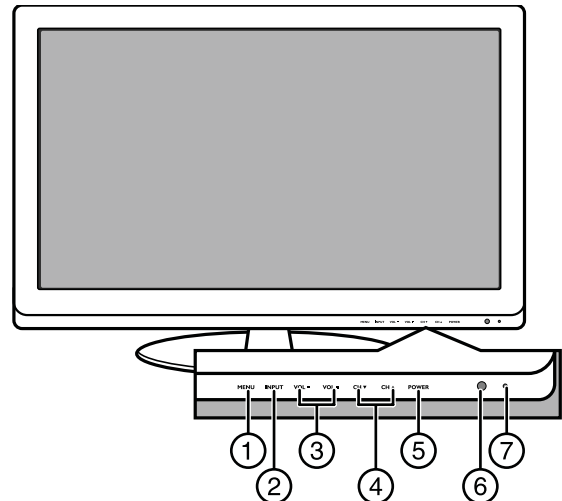

#	Component	Description
1	MENU	Press to open the on-screen menu.
2	INPUT	Press to select the video input source.
3	VOL+/VOL-	Press to increase or decrease the volume.
4	CH ▼/CH ▲	Press to go to the next or previous channel in the channel list.
5	POWER button	Press to turn on your TV, or wake the TV up from DPMS (Display Power Management System) mode. Press again to put your TV in standby mode. For more information, see "Turning your TV on or off" on page 11.
6	Remote sensor	Receives signals from the remote control. Do not block.
7	Power indicator	Lights blue when your TV is turned on. Lights red when your TV is in standby mode. Flashes red when your TV receives no signal from VGA and enters DPMS mode. Off when power cord is unplugged. For more information, see "Turning your TV on or off" on page 11.

## Back

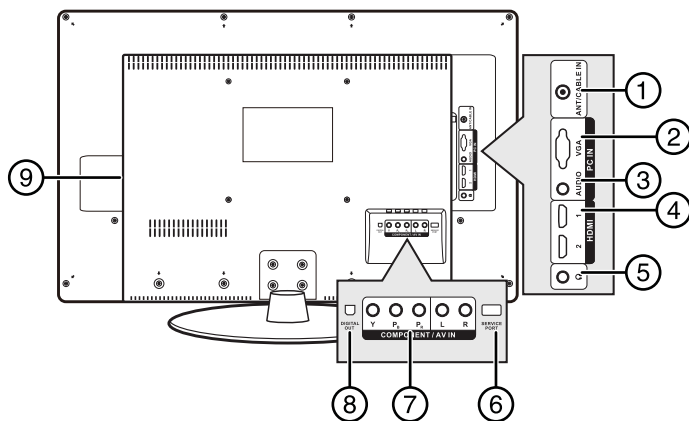

##	Component	Description
1	<b>ANT/CABLE IN</b> jack	Connect an antenna, cable TV, or a satellite box to this jack. For more information, see "Connecting an antenna, cable TV, or satellite TV box" on page 8.
2	<b>PC IN VGA</b> jack	Connect computer video to this jack. For more information, see "Connecting a computer" on page 9.
3	<b>PC IN AUDIO</b> jack	Connect computer audio to this jack. For more information, see "Connecting a computer" on page 9.
4	<b>HDMI</b> jacks	Connect an HDMI device, such as a cable box or DVD player, to these jacks. An HDMI cable carries both video and audio, so you do not need to make an audio connection. For more information, see "Connecting an HDMI device (best)" on page 8.
5	Headphone jack	Plug headphones into this jack.
6	Service port	For software update only. Do not use.
7	<b>COMPONENT/AV IN</b> jacks (shared)	Connect a component video device to the Y, PB, and PR jacks. Connect the video cable from a composite video device to the Y jack. For more information, see "Connecting a component video device (better)" on page 8.
8	<b>DIGITAL OUT</b> jack	Connect a digital sound system, such as a digital audio amplifier, to this jack. See "Connecting a digital audio amplifier" on page 10.
9	<b>AC IN</b> jack	Connect the supplied power cord here.

## Remote control

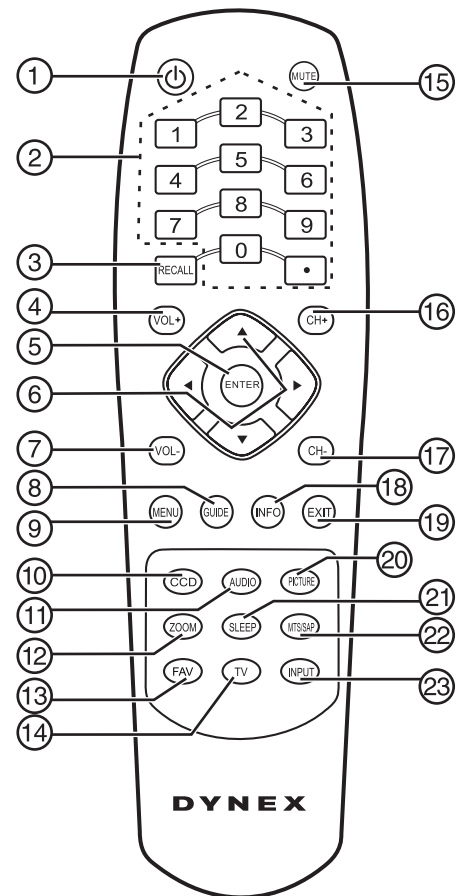

#	Button	Description
1	Power	Press to turn on your TV, or wake the TV up from DPMS mode. Press again to put your TV in standby mode. For more information, see "Turning your TV on or off" on page 11.
2	Numbers/.	Press the number buttons to enter channel numbers or the parental control password. Press the . button to select a digital sub-channel. For more information, see "Selecting a channel" on page 11.
3	<b>RECALL</b>	Press to go to the last viewed channel.
4	<b>VOL+</b>	Press to increase the volume.
5	<b>ENTER</b>	Press to confirm selections in an on-screen menu or to open a submenu.
6	Directional arrows	Press direction buttons to navigate in the on-screen menus.
7	<b>VOL-</b>	Press to decrease the volume.
8	<b>GUIDE</b>	Press to open the DTV program guide (if available). For more information, see "Displaying additional information" on page 11.
9	<b>MENU</b>	Press to open the on-screen menu.
10	<b>CCD</b>	Press to select a closed captioning mode. For more information, see "Selecting the closed captioning mode" on page 22.

#	Button	Description
11	AUDIO	Press to select the sound mode. You can select <b>Standard, News, Music, Theater, or Custom</b> . For more information, see "Adjusting sound settings" on page 14.
12	ZOOM	Press to select the aspect ratio. You can select <b>Auto, Normal, Zoom, Wide, or Cinema</b> . For more information, see "Adjusting the TV picture" on page 13.
13	FAV	Press to open the favorite channel list.
14	TV	Press to select <b>TV</b> as the input source.
15	MUTE	Press to turn off the sound. Press again to turn on the sound.
16	CH+	Press to go to the next channel in the channel list. For more information, see "Selecting a channel" on page 11.
17	CH-	Press to go to the previous channel in the channel list. For more information, see "Selecting a channel" on page 11.
18	INFO	Press to display the information banner. For more information, see "Displaying additional information" on page 11.
19	EXIT	Press to return to the previous on-screen menu layer or close the menu.
20	PICTURE	Press to select the picture mode. You can select <b>Vivid, Standard, Energy Savings, Theater, Sports, or Custom</b> . For more information, see "Adjusting the TV picture" on page 13.
21	SLEEP	Press to set the sleep timer. For more information, see "Setting the sleep timer" on page 22.
22	MTS/SAP	Press to select the audio mode. For analog channels, you can select <b>STEREO, SAP</b> (secondary audio program), or <b>MONO</b> . For digital channels, you can select the audio track (if more than one track is available). For more information, see "Adjusting the sound" on page 14.
23	INPUT	Press to open the <i>SOURCE LIST</i> menu to select the video input source, then press <b>ENTER</b> to confirm. For more information, see "Selecting the video input source" on page 11.

## Using the remote control

### Installing remote control batteries

#### To install remote control batteries:

- 1 Open the battery compartment cover by lifting it off when you press the release button.

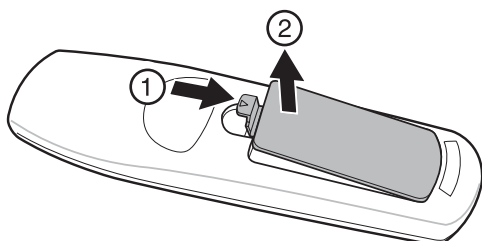

- 2 Insert two AAA batteries into the battery compartment. Make sure that the + and – symbols on the batteries match the + and – symbols in the battery compartment.

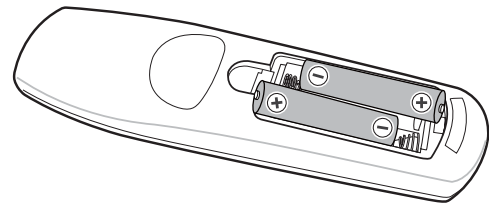

- 3 Replace the cover.

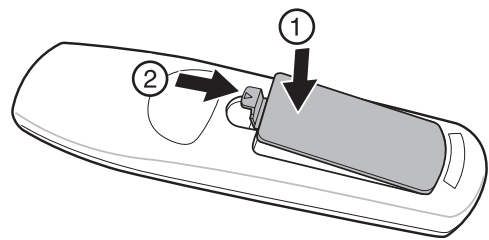

#### Notes:

Do not mix different types of batteries.

Do not mix old and new batteries.

Remove batteries when they no longer have a charge. Chemicals may leak into the battery compartment. Battery chemicals can cause a rash. If chemicals leak, clean the battery compartment with a cloth.

Remove the batteries if you do not intend to use the remote control for an extended amount of time.

Do not dispose of batteries in a fire. Dispose of them as hazardous waste.

### Aiming the remote control

#### To use the remote control:

- Point the remote control towards the remote sensor on the front of your TV.

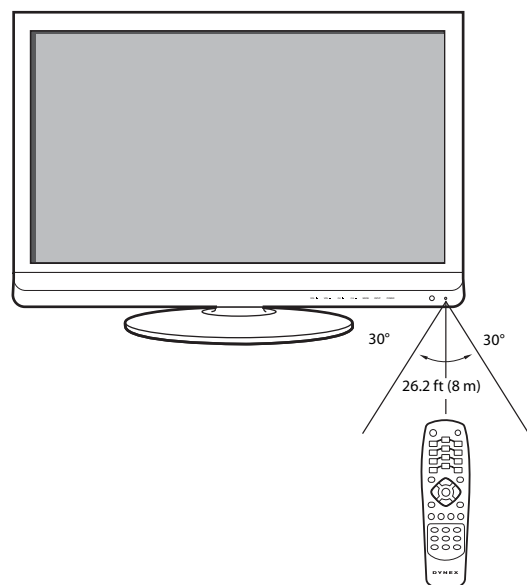

#### Notes:

Do not expose the remote control to shock or liquids.

Do not use the remote control in an area with high humidity.

Do not place the remote control in direct sunlight.

Do not place objects, such as furniture, between the remote control and the remote sensor.

The remote control may not work if direct sunlight or bright light shines on the remote sensor. Either move your TV or change the angle at which you use the remote control.

## Programming a universal remote control to work with your TV

You can operate your TV with a new or existing universal remote control.

### To program a universal remote control:

- 1 Find the code for your universal remote control by identifying its model (or your set-top box's remote control manufacturer and model) on the charts below, then make note of the numbered code below it. You will use the numbered code to program your remote control to work with your TV.

Dynex TV codes for universal remote controls (for all Dynex TVs manufactured after Jan. 1, 2007)				
Universal remote control manufacturer and model				
Philips PHDVD5, PH5DSS, PMDVR8, PDVR8	DirectTV RC23	RCA RCU807	One for All URC-6690	Sony RM-VL600
<b>115</b>	<b>10463</b>	<b>135</b>	<b>0464</b>	<b>8043</b>
Set-top box manufacturer and model				
Comcast M1057	Dish Network VIP508, VIP622	Motorola DRC800	TIVO Series 3, HD	
<b>0463</b>	<b>720</b>	<b>0463</b>	<b>0091</b>	

Codes for other remote controls are available online at: [www.dynexproducts.com/support.html](http://www.dynexproducts.com/support.html)

### Tips:

- The brand name is often visible on the front of the universal remote control, and the model number is often visible on the back.
  - If your universal remote control isn't listed on the chart, refer to your universal remote control's instructions and try codes for the brands Orion, Emerson, Memorex, Sansui, Sylvania, or Zenith. You may need to try several codes before finding a match.
- 2 Follow your universal remote control's instructions to enter the code you found in Step 1.
    - If your universal remote control has a code search feature, run a code search to identify a code that matches your TV. See your universal remote control's instructions for details.
    - If your universal remote control has a "Learn" feature, you can manually program it using your TV remote to "teach" the commands one at a time. See your universal remote control's instructions for details.
  - 3 If all else fails, you must use a different universal remote control that can operate both your set-top box and your TV. Five such remotes are listed on the chart, but many other compatible models are available in the market.

For more help, call technical support for your universal remote control or set-top box manufacturer, or call the Dynex Customer Care Center at 1-800-305-2204. For Mexico markets, call 01-800-926-3020.

## Making connections

### Cautions:

Check the terminals for position and type before making any connections.

Loose connections can result in image or color problems. Make sure that all connections are tight and secure.

The external audio/video equipment shown in these illustrations may be different from your equipment. If you have questions, refer to the user manual that came with your equipment.

Always turn the power off when connecting external equipment.

## Selecting a location

You should select a location for your TV:

- Where direct light does not reflect on the screen
- That has indirect and soft lighting
- Where the TV has access to an antenna or cable TV connection
- Where the TV has access to a power outlet

**Caution:** Watching TV in total darkness or with a reflection on the screen may cause eye strain.

## Connecting the power

### To connect the power:

- Plug the AC cord into an AC power outlet.

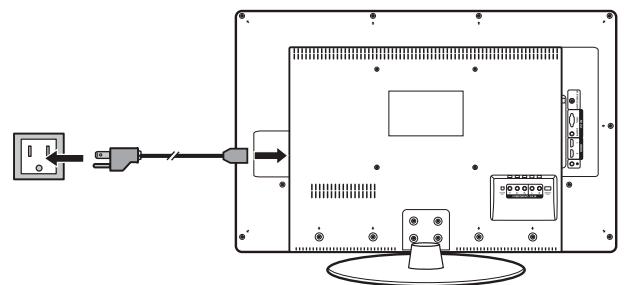

### Notes:

The AC plug on your TV may be different from the one shown.

Your TV should only be operated from the power source indicated on the label.

Always unplug the AC power cord from the AC power outlet when you will not be using your TV for an extended period of time.

## Connecting an HDMI device (best)

### To connect an HDMI device:

- 1 Make sure that your TV's power cord is unplugged and the HDMI device is turned off.
- 2 Connect an HDMI cable to the **HDMI OUT** jack on the HDMI device.

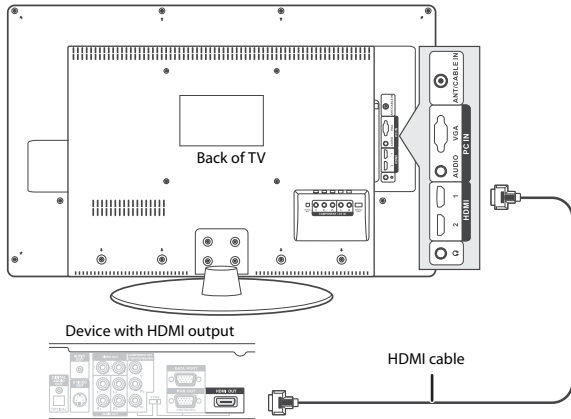

- 3 Connect the other end of the cable to the **HDMI 1** or **HDMI 2** jack on the back of your TV.

### To play from the HDMI device:

- 1 Turn on your TV, then press **INPUT**. The *Source List* menu opens.
- 2 Press **▲** or **▼** to select **HDMI 1** or **HDMI 2**, then press **ENTER**.
- 3 Turn on the HDMI device, and set it to the correct output mode. See the HDMI device's user guide for more information.

**Note:** If the external device has DVI output only, use a DVI-to-HDMI adapter to connect to the **HDMI 1** or **HDMI 2** jack, then connect an audio cable to the **PC IN AUDIO** jack.

## Connecting a component video device (better)

### To connect a component video device:

- 1 Make sure that your TV's power cord is unplugged and the component video device is turned off.
- 2 Connect a component video cable to the **COMPONENT OUT** jacks on the component video device.

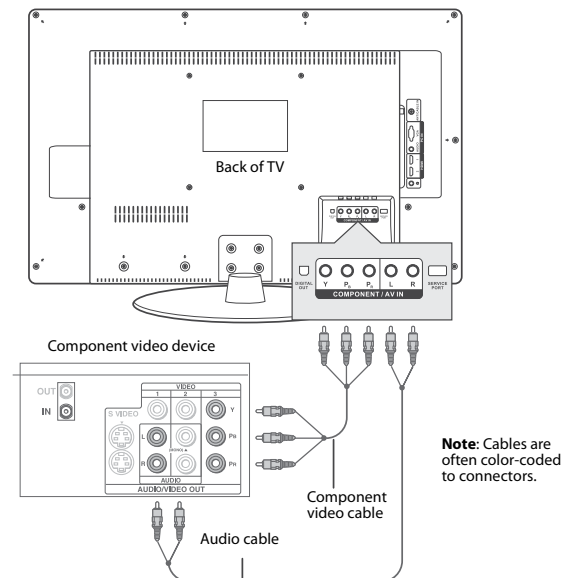

- 3 Connect the other end of the component video cable to the **Y/VIDEO**, **Pb**, and **Pr** jacks on the **COMPONENT/AV IN** panel on the back of your TV.
- 4 Connect an audio cable to the **AUDIO OUT** jacks (L/R) on the component device.
- 5 Connect the other end of the audio cable to the **L** and **R** jacks on the **COMPONENT/AV IN** panel on the back of your TV.

### To play from a component device:

- 1 Turn on your TV, then press **INPUT**. The *Source List* menu opens.
- 2 Press **▲** or **▼** to select **AV**, then press **ENTER**.
- 3 Turn on the component video device and set it to the correct output mode. See the component video device's user guide for more information.

## Connecting an antenna, cable TV, or satellite TV box

### To connect an antenna, cable TV, or satellite TV box:

- 1 Connect one end of a 75 ohm cable (not included) to the **RF OUT** jack on the antenna or on the cable or satellite TV box.

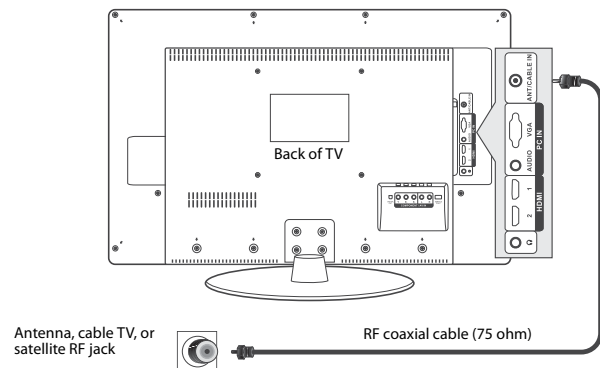

- 2 Connect the other end of the cable to the **ANT/CABLE IN** jack on the back of your TV.

If you are connecting a satellite TV or cable box, you can use one of the following (if available):

- Best - HDMI cable
- Better - Video component cables
- Good - AV cables
- Acceptable - 75-ohm coaxial cable

### Notes:

Use a 75 ohm cable to eliminate interference and noise from radio waves.

Do not bundle the 75 ohm cable with the power cord or other cables.

If the antenna is not installed correctly, contact qualified service personnel to correct the problem.

## Connecting a VCR, camcorder, or game (good)

Connect the equipment using the best available connection. Use the component jacks (better,) or an HDMI jack (best), if available.

### To connect a VCR:

- 1 Make sure that your TV's power cord is unplugged and the VCR, camcorder, or game is turned off.

- 2 Connect a standard AV cable (not included) to the **AV VIDEO OUT** jack on the VCR, camcorder, or game.

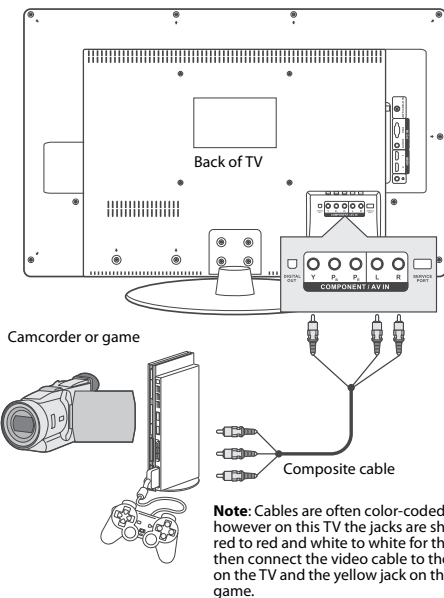
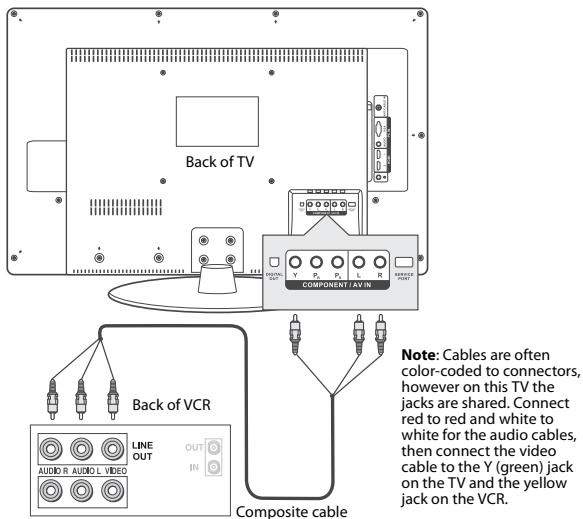

- 3 Connect the other end of the cable to the **Y** (green) jack on the **COMPONENT/AV IN** panel on the back of your TV.
- 4 Connect an audio cable to the **AV AUDIO OUT** jacks on the device.
- 5 Connect the other end of the audio cable to the **L** and **R** jacks on the **COMPONENT/AV IN** panel on the back of your TV.

**To play from the VCR, camcorder, or game:**

- 1 Turn on your TV, then press **INPUT**. The **Source List** menu opens.
  - 2 Press **▲** or **▼** to select **AV**, then press **ENTER**.
  - 3 Turn on the VCR, insert a videotape, then press **PLAY** on the VCR.
- OR -
- Turn on the camcorder or game, and set it to the correct output mode. See the camcorder's or game's user guides for more information.

## Connecting a computer

*Tip: Some computers have an HDMI connector, which can be used for a better picture and sound.*

**To connect a computer:**

- 1 Make sure that your TV's power cord is unplugged and the computer is turned off.
- 2 Connect a VGA cable to the **VGA** jack on the computer, then connect the other end of the cable to the **PC IN VGA** jack on the back of your TV.

*Note: The VGA cable should be a 15-pin D-Sub (analog RGB) cable.*

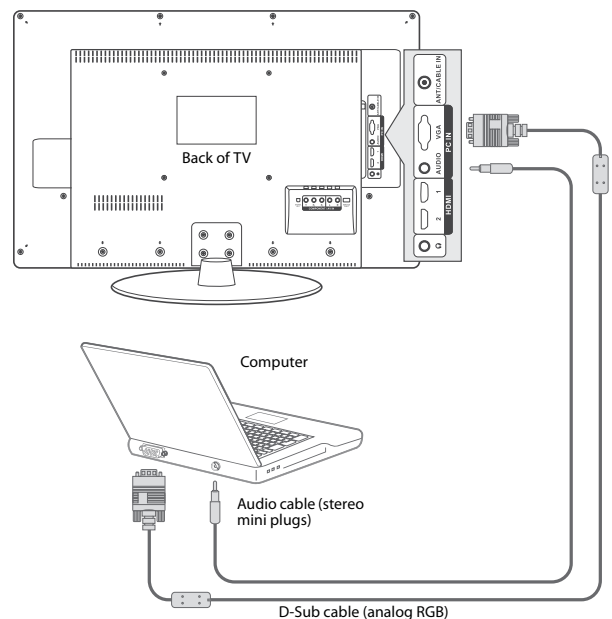

- 3 Connect an audio cable to the **AUDIO OUT** jack on the computer, then connect the other end of the cable to the **AUDIO** jack on the back of your TV.

*Note: The audio cable should have a stereo mini plug.*

**To play video from a computer:**

- 1 Turn on your TV, then press **INPUT**. The **Source List** menu opens.
- 2 Press **▲** or **▼** to select **VGA**, then press **ENTER**.
- 3 Turn on the computer, then adjust the display properties, if necessary.

## Connecting headphones

**To connect headphones:**

- Connect the headphones to the headphone jack on the side of your TV.

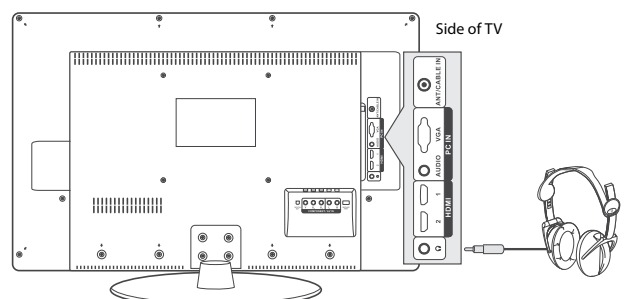

**Caution:** Loud noise can damage your hearing. When using headphones, use the lowest volume setting that still lets you hear the sound.

**Note:** The TV mutes automatically when you plug in the headphones.

## Connecting a digital audio amplifier

You can connect your TV's audio to a digital audio amplifier or home theater system.

### To connect a digital audio amplifier:

- 1 Make sure that your TV's power cord is unplugged and the audio device is turned off.
- 2 Plug an optical digital cable into the DIGITAL OUT jack on the back of your TV.
- 3 Plug the other end of the digital optical cable into the digital optical input jack of your digital audio amplifier or home theater system.

**Note:** The **DIGITAL OUT** jack only works with digital sources.

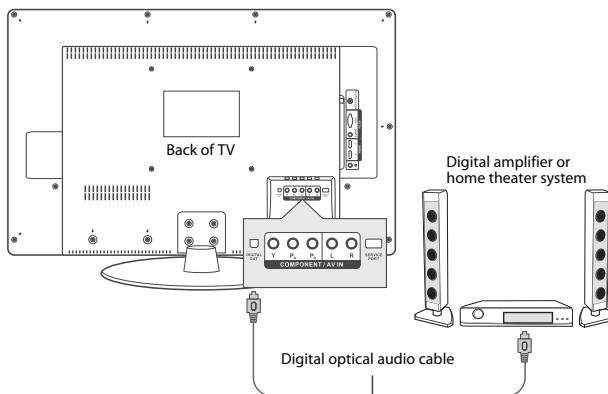

## Turning on your TV for the first time

### To configure your TV:

- 1 Make sure that you have inserted the batteries in the remote control, connected your devices to the TV, and connected the AC power.
- 2 Press **Power**, then wait several seconds. The initial *Setup Wizard* screen opens (only the first time you turn on your TV).



- 3 Press **▲** or **▼** to select the menu language you want, then press **ENTER**. The *Time* screen opens.

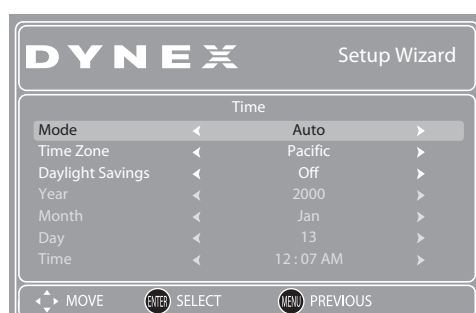

- 4 Press **▲** or **▼** to highlight **Mode**, then press **◀** or **▶** to select **Manual** (to set the date and time manually), or **Auto** (the date and time are automatically set by the TV signal source, based on the time zone you select).
- 5 Press **▲** or **▼** to highlight **Time Zone**, then press **◀** or **▶** to select your time zone. You can select **Pacific, Alaska, Hawaii, Newfoundland, Atlantic, Eastern, Central, or Mountain**.
- 6 If your viewing area observes daylight savings time, press **▲** or **▼** to highlight **Daylight Savings**, then press **◀** or **▶** to select **On**.
- 7 If you select **Manual** mode, make the settings as follows:
  - Press **▲** or **▼** to highlight **Year, Month, or Day**, then press **◀** or **▶** to adjust the setting.
  - Set the time by pressing **▲** or **▼** to highlight **Time**, then press **◀** or **▶** to highlight the hour, minute, or AM/PM field. Press **▲** or **▼** to adjust the setting.
- 8 Press **ENTER**. The *Choose your Picture Mode* screen opens.

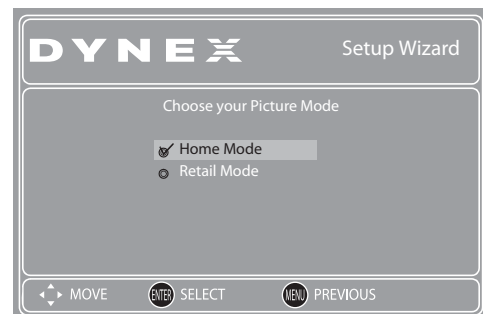

- 9 Press **▲** or **▼** to select **Home Mode** or **Retail Mode**, then press **ENTER**.

If you select **Home Mode**, the *Choose your TV source* screen opens.

-OR-

If you select **Retail Mode**, a message stating "Are you sure you want Retail mode? Since in this mode Energy saving is not realized." appears. Select **Yes** to proceed or **No** to go to the previous screen.

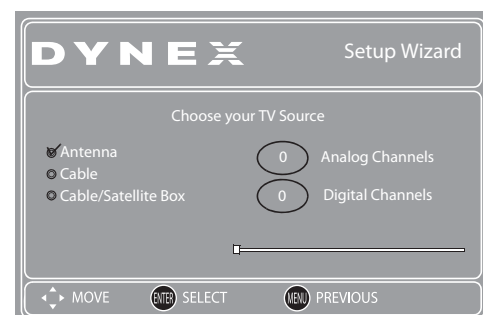

- 10 Press **▲** or **▼** to select **Antenna, Cable, or Cable/Satellite Box**, depending on the type of connection you have.
  - If you are using an antenna for a standard or HD TV signal, select **Antenna**.
  - If your cable is connected directly to the TV (without a tuner box), select **Cable**.
  - If your cable is connected to your TV through a tuner box, select **Cable/Satellite Box**.
- 11 Press **ENTER** when you have made your selection. The channel scan screen opens.

If you selected **Antenna** or **Cable**, your TV automatically scans for available channels in your area and stores the channel information in the channel list. This may take several minutes. While scanning, the TV displays a progress report.

– OR –

If you selected **Cable/Satellite Box**, the auto scan is not necessary and the screen will ask you to select the correct input source for your set top box. Press **EXIT** to close the menu.

**Note:** Channel scan can take up to 20+ minutes.

You can press **EXIT** at any time to stop the auto scan, but you will need to run the auto scan again to create a channel list.

- 12 Select the corresponding video input source through the *Source List*.

## Understanding the basics

### Turning your TV on or off

**To turn your TV on or off (standby mode):**

- 1 Plug the power cord into an AC power outlet.
- 2 Press **⏻** (power). Your TV turns on.
- 3 Press **⏻** again to turn off your TV. When you turn off your TV, it goes into standby mode.

**Warning:** When your TV is in standby mode, it is still receiving power. To completely disconnect power, unplug the power cord.

**Note:** If your TV does not receive an input signal for several minutes, it automatically goes into standby mode.

### Selecting the video input source

**To select the video input source:**

- 1 Turn on your TV, then press the **INPUT** key on the remote, or the **INPUT** button on the TV. The *Source List* menu opens.

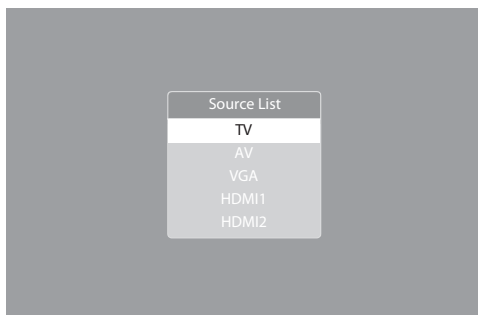

- 2 Press **▲** or **▼** to highlight the video source, then press **ENTER**. You can also press **TV** to switch to **TV mode**.

### Selecting a channel

**To select a channel:**

- Press **CH+** or **CH-** to go to the next or previous channel on the memorized channel list.
- Press the number buttons to enter the analog or digital (main) channel number you want, then wait for the channel to change, or press **ENTER** to change the channel immediately.
  - To select a digital sub-channel, press the number buttons to select the main digital channel, then press the dot (.) button to select the sub-channel. Wait for the channel to change, or press **ENTER** to change the channel immediately.

**Note:** Button presses must be within three seconds of each other.

- Press **RECALL** to go to the last channel viewed.

### Adjusting the volume

**To adjust the volume:**

- Press **VOL+** or **VOL-** to increase or decrease the volume.
- Press **MUTE** to temporarily turn off all sound. Press **MUTE** again to restore the sound.

### Displaying additional information

**To display additional information:**

- Press **INFO** to show an information banner. The information banner shows current program information such as resolution.
  - Digital mode information—Displays program name, time, channel number, channel label, TV rating, resolution, and current signal strength, and audio information.
  - Analog mode information—Displays channel number, audio information, TV rating, resolution, channel label, and current signal strength.
- Press **GUIDE** to show the digital program guide, which may show a list of available programs, program times, and program summaries, depending on the information provided by the broadcaster.

### On-screen menu overview

#### PICTURE menu

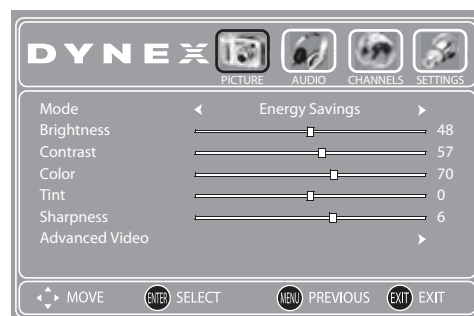

#### AUDIO menu

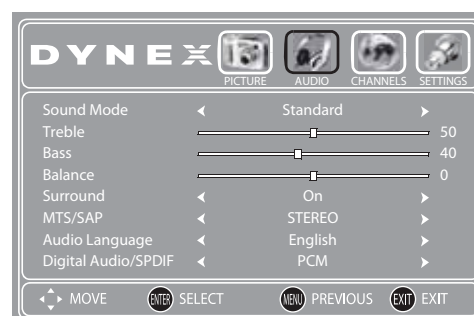

### CHANNELS menu



### SETTINGS menu



**Notes:**

Depending on the signal source selected, you may see different options on your screen. The above menus are shown in TV mode.

Menu items that are not selectable are grayed out. Menus in this manual are described in TV mode, unless otherwise indicated.

The illustrations and screens shown in the manual are for explanation purposes and may vary from the actual screens on your TV.

## Navigating the menus

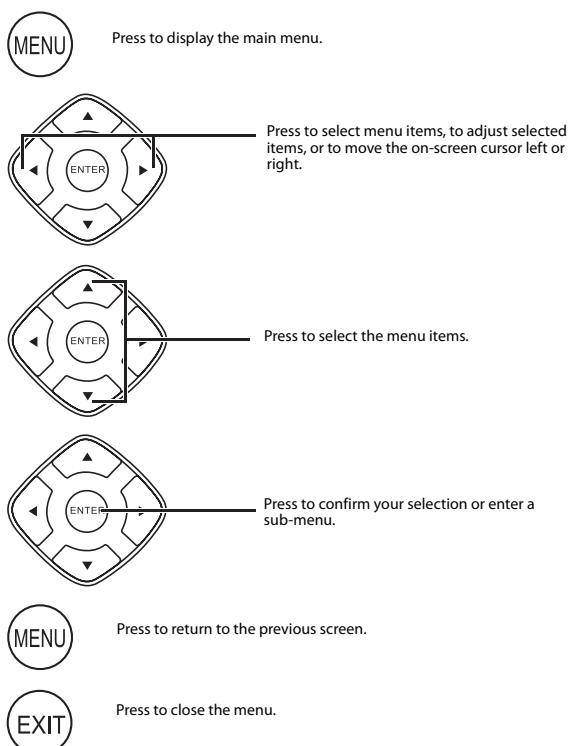

## Adjusting basic settings

To adjust basic settings:

1 Press **MENU**. The **PICTURE** menu opens.

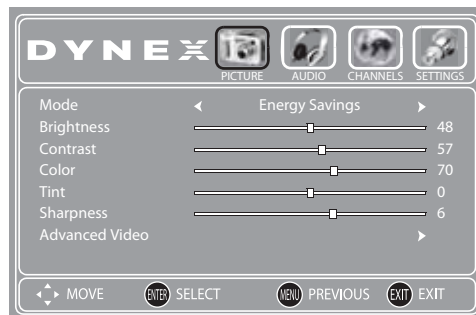

2 Press **◀** or **▶** to highlight **SETTINGS**, then press **▼**. The **SETTINGS** menu opens.



3 Press **▲** or **▼** to highlight an option, then press **ENTER** to enter the sub-menu. You can select:

- **Parental Controls**—Control which programs/movies your children can watch, based on industry ratings.
- **Language**—Set the menu language .
- **Time**—Set the clock and sleep timer.
- **Closed Caption**—Turn closed captioning on or off. Also lets you set closed caption options.
- **Input Labels**—Create a unique name for a device connected to your TV's input jacks.
- **Computer Settings**—Adjust picture settings to optimize a computer display. (This menu becomes available only when a computer display is connected to the television.)
- **Reset to Default**—Reset most TV settings for the current source to factory default values.

4 Press **MENU** to return to the previous menu, or press **EXIT** to close the menu.

## Adjusting the picture

### Adjusting the TV picture

To adjust the TV picture:

- 1 Press **MENU**. The on-screen menu opens with the **PICTURE** menu displayed.

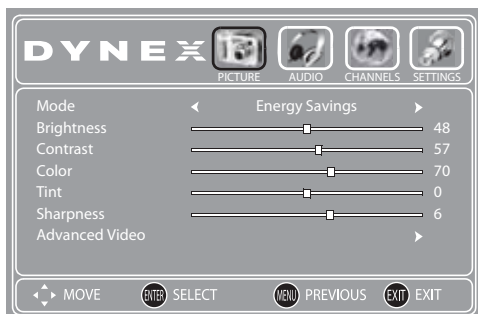

- 2 Press **▲** or **▼** to highlight an option, then press **◀** or **▶** to adjust the option. You can select:
  - **Mode**—Selects the picture mode. You can select:
    - **Vivid** (a bright and vivid picture)
    - **Standard** (a standard picture)
    - **Energy Savings** (the backlight brightness is decreased)
    - **Custom** (customized picture).

- **Mode**—Selects the picture mode. You can select:
  - **Vivid** (a bright and vivid picture)
  - **Standard** (a standard picture)
  - **Energy Savings** (the backlight brightness is decreased)
  - **Custom** (customized picture).

**Note:** You can also press **PICTURE** on the remote control to select the picture mode.

- **Brightness**—Adjusts the brightness.
- **Contrast**—Adjusts the contrast.
- **Color**—Adjusts the color saturation.
- **Tint**—Adjusts the image tint.
- **Sharpness**—Adjusts the sharpness.

- 3 Press **▲** or **▼** to highlight **Advanced Video**, then press **ENTER** to enter the sub-menu.

- 4 Press **◀** or **▶** to adjust the option. You can select:
  - **Aspect Ratio**— Selects the aspect ratio of the picture. You can select:
    - **Auto** (selects the correct aspect ratio automatically. Available only when Auto Zoom is turned ON).
    - **Normal** (selects the correct aspect ratio to match the source image).
    - **Zoom** (enlarges the picture but may crop the top and bottom).
    - **Wide** (shows a full-screen picture).
    - **Cinema** (stretches the picture at the edges, but maintains a good aspect ratio at the center of the screen).
  - **Overscan**—Extends part of the display past the visible area of the screen. The resulting picture will “zoom in” on the center of the image. Turn this **On** to adjust the picture’s reproduction rate.
  - **Color Temperature**—Selects the color temperature. You can select **Warm** (to enhance the reds), **Cool** (to enhance the blues), or **Normal**.
  - **Noise Reduction**—Selects the noise reduction mode to reduce picture noise (snow). You can select **Low**, **Middle**, **High**, or **Off**.
  - **Backlight**—Adjusts the screen backlight.
  - **Adaptive Contrast**—Turn this **On** to optimize the picture display for a more vivid image.

- **Aspect Ratio**— Selects the aspect ratio of the picture. You can select:
  - **Auto** (selects the correct aspect ratio automatically. Available only when Auto Zoom is turned ON).
  - **Normal** (selects the correct aspect ratio to match the source image).
  - **Zoom** (enlarges the picture but may crop the top and bottom).
  - **Wide** (shows a full-screen picture).
  - **Cinema** (stretches the picture at the edges, but maintains a good aspect ratio at the center of the screen).
- **Overscan**—Extends part of the display past the visible area of the screen. The resulting picture will “zoom in” on the center of the image. Turn this **On** to adjust the picture’s reproduction rate.
- **Color Temperature**—Selects the color temperature. You can select **Warm** (to enhance the reds), **Cool** (to enhance the blues), or **Normal**.
- **Noise Reduction**—Selects the noise reduction mode to reduce picture noise (snow). You can select **Low**, **Middle**, **High**, or **Off**.
- **Backlight**—Adjusts the screen backlight.
- **Adaptive Contrast**—Turn this **On** to optimize the picture display for a more vivid image.

- **Dynamic Contrast Ratio**—Enhances the contrast ratio between the light and dark areas of the picture. This feature enables automatic contrast adjustment, based on the picture brightness.

- 5 Press **MENU** to return to the previous menu, or press **EXIT** to close the menu.

### Adjusting the computer image

**Note:** Make sure that your TV is in VGA mode. For more information, see “Selecting the video input source” on page 11.

To adjust the computer image:

- 1 Press **MENU**. The on-screen menu opens with the **PICTURE** menu displayed.

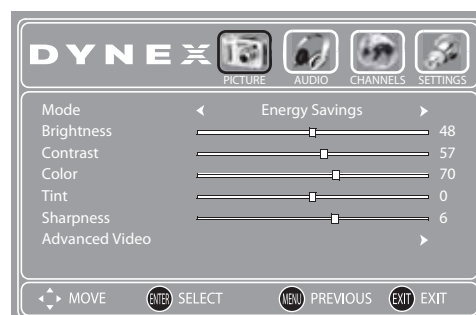

- 2 Press **◀** or **▶** to highlight **SETTINGS**, then press **▼**. The **SETTINGS** menu opens.

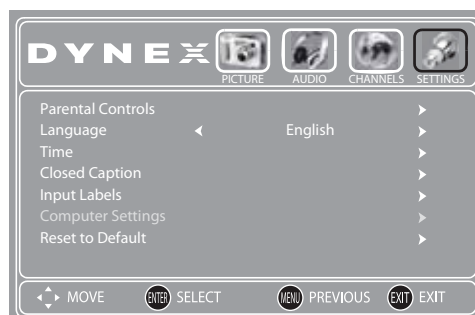

- 3 Press **▲** or **▼** to highlight **Computer Settings**, then press **ENTER**. The **Computer Settings** screen opens.

- 4 Press **▲** or **▼** to highlight an option, then press **◀** or **▶** to adjust the option. You can adjust:
  - **Auto Adjust**—Automatically adjusts the image settings such as position and phase
  - **H.Position**—Moves the image right or left
  - **V.Position**—Moves the image up or down
  - **Clock**—Adjusts the sample frequency
  - **Phase**—Adjusts the focus of stable images

- 5 Press **MENU** to return to the previous menu, or press **EXIT** to close the menu.

# Adjusting the sound

## Adjusting sound settings

To adjust the sound:

- 1 Press **MENU**. The on-screen menu opens.

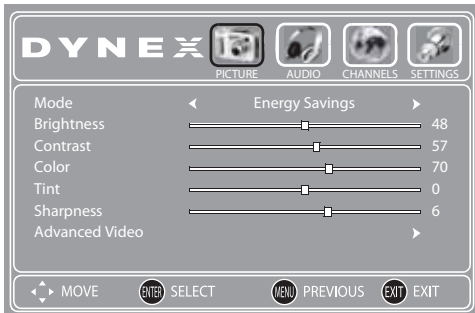

- 2 Press **◀** or **▶** to highlight **AUDIO**, then press **▼**. The **AUDIO** menu opens.



- 3 Press **▲** or **▼** to highlight an option, then press **◀** or **▶** to adjust the option. You can select:
  - **Sound Mode**—Selects the sound mode. You can select:
    - **Standard** (for normal programs)
    - **News** (for news programs)
    - **Music** (for musical programs)
    - **Theater** (for movies)
    - **Custom** (for a customized sound mode)

- **Treble**—Adjusts the high sounds.
- **Bass**—Adjusts the low sounds.
- **Balance**—Adjusts the balance between the left and right audio channels.
- **Surround**—Turns the surround sound effect on or off.
- **MTS/SAP**— (analog TV channels only) You can select: **Mono** (if there is noise or static on weak stereo broadcasts), **Stereo** (for programs broadcast in stereo), or **SAP** (to listen to a secondary audio program, if available).

**Tip:** You can also press **AUDIO** on the remote control one or more times to select the sound mode.

- **Note:** **Mono** is automatically selected if the program is broadcast in mono.

**Tip:** You can also press **MTS/SAP** on the remote control to select an audio language, if available.

- **Audio Language**—(DTV channels only) Selects an alternate audio language, if available.

**Tip:** You can also press **MTS/SAP** on the remote control to select an audio language, if available.

- **Digital Audio/SPDIF**—Selects the preferred audio format for digital audio signals. This feature is only available on digital channels or when using an HDMI device. You can select **Off**, **PCM**, or **RAW**.

- 4 Press **MENU** to return to the previous menu, or press **EXIT** to close the menu.

## Playing TV audio only

You can turn off the picture on your TV and listen to only the program audio.

To play only the TV audio:

- 1 Press **MENU**. The on-screen menu opens.

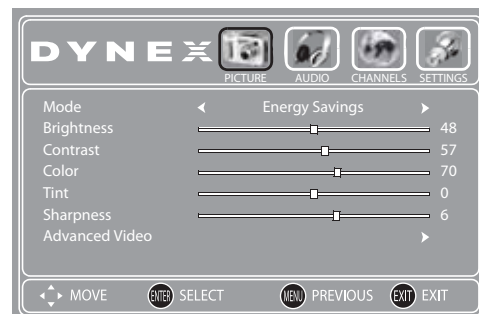

- 2 Press **◀** or **▶** to highlight **CHANNELS**, then press **▼**. The **CHANNELS** menu opens.



- 3 Press **▲** or **▼** to highlight **Audio Only**, then press **◀** or **▶** to select **On**.
- 4 Press **EXIT** to close the menu. After pressing **EXIT**, the picture will turn off in approximately 3 to 5 seconds.

**Notes:**

*Audio Only works only when the input source is TV and your TV is receiving a broadcast signal.*

*To exit Audio Only mode, press any button. When you exit Audio Only mode, the Audio Only option is automatically reset to Off.*

## Changing channel settings

### Automatically scanning for channels

To auto scan for channels:

- 1 Press **MENU**. The on-screen menu opens.

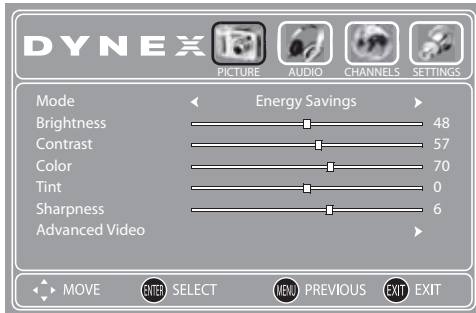

- 2 Press **◀** or **▶** to highlight **CHANNELS**, then press **▼**. The **CHANNELS** menu opens.



- 3 Press **▲** or **▼** to highlight **Auto Channel Search**, then press **ENTER**.
- 4 Press **▲** or **▼** to highlight the TV signal source, then press **ENTER** to start scanning for channels in that channel group.

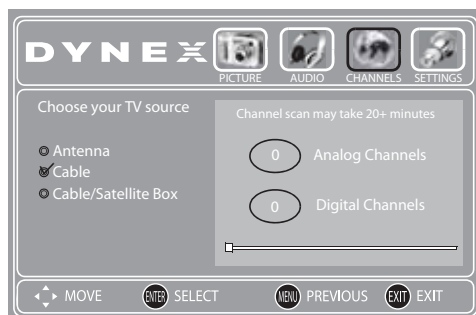

You can select:

- **Antenna**—VHF and UHF channels
- **Cable**—Cable TV channels (no cable box)
- **Cable/Satellite Box**—Cable or satellite TV tuner box.

Channel auto scan is not required if you select this option.

Auto Channel Search may take a while to complete. The status is displayed while your TV is scanning for available channels. You can press **EXIT** to exit Auto Channel Search prior to completion, but you will need to run Auto Channel Search later to complete the process. Auto Channel Search creates a list of available/receivable channels for the selected input source.

### Hiding channels

You can delete channels from the channel list so that your TV skips the channels when you press **CH+/CH-**. You can still tune to the hidden channel by using the number buttons.

To hide a channel:

- 1 Press **MENU**. The on-screen menu opens.

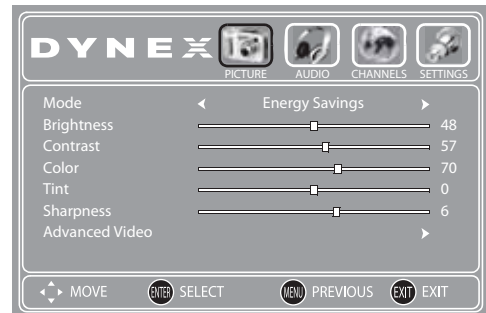

- 2 Press **◀** or **▶** to highlight **CHANNELS**, then press **▼**. The **CHANNELS** menu opens.



- 3 Press **▲** or **▼** to highlight **Add/Skip Channels**, then press **ENTER**. The channel list opens.

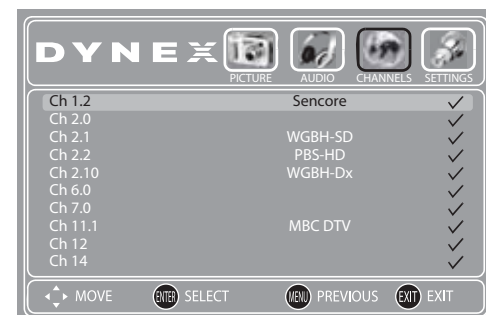

- 4 Press **▲** or **▼** to highlight the channel you want to hide (the default is to show the channel), then press **ENTER**. The checkmark is removed from the channel.

**Note:** If the list has more than one page, press **◀** or **▶** to scroll through the pages.

- 5 Press **EXIT** to close the menu.

## Setting up a favorite channel list

You can create a favorite channel list so you can quickly browse through your favorite channels by pressing **FAV**, then selecting a channel from the favorite channel list.

To set up the favorite channel list:

- 1 Press **MENU**. The on-screen menu opens.

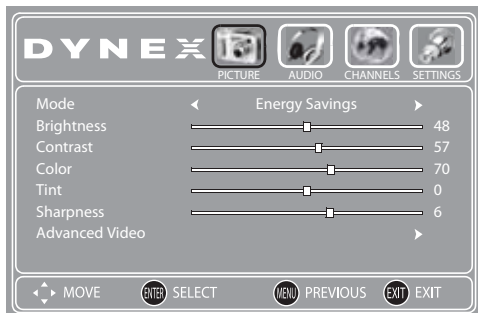

- 2 Press **◀** or **▶** to highlight **CHANNELS**, then press **▼**. The **CHANNELS** menu opens.



- 3 Press **▲** or **▼** to highlight **Favorites**, then press **ENTER**. The favorite channel list opens.

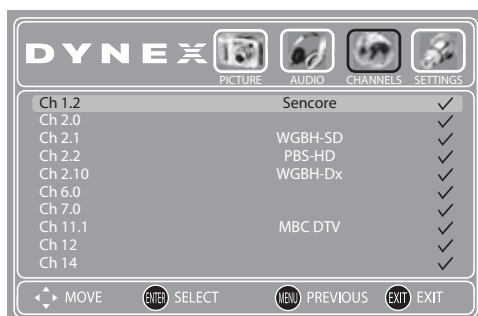

- 4 Press **▲** or **▼** to highlight the channel you want to add to the favorite list, then press **ENTER** to mark the channel. A check mark appears if the channel is added to the list. The check mark disappears if you delete the channel from the list.

*Note: If the list has more than one page, press **◀** or **▶** to scroll through the pages.*

- 5 Press **EXIT** to close the menu.
- 6 To select a channel in the favorite channel list, press **FAV**, press **▲** or **▼** to highlight the channel, then press **ENTER**.

## Adding or changing a channel label

If a channel is not already labeled, you can label the channel to make it easier to identify. You can also relabel a channel that is already labeled.

To label a channel:

- 1 Press **MENU**. The on-screen menu opens.

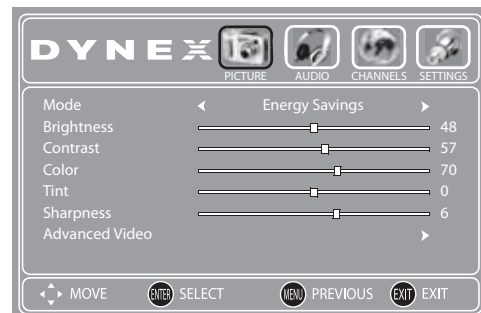

- 2 Press **◀** or **▶** to highlight **CHANNELS**, then press **▼**. The **CHANNELS** menu opens.



- 3 Press **▲** or **▼** to highlight **Channel Labels**, then press **ENTER**. The Channel Label screen opens.

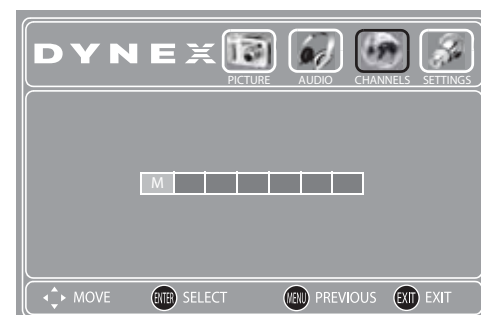

- 4 Press **▲** or **▼** to select a character, then press **◀** or **▶** to move to the next position. Repeat to add more characters.
- 5 Press **EXIT** to close the menu.

## Fitting the picture to the screen

In TV mode (only), your TV can automatically adjust the picture so that everything fits in the viewable area of the screen.

### To fit the picture to the screen:

- 1 Press **MENU**. The on-screen menu opens.

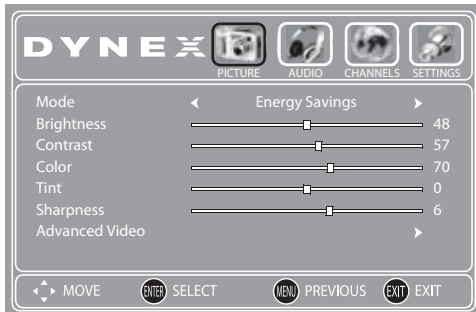

- 2 Press **◀** or **▶** to highlight **CHANNELS**, then press **▼**. The **CHANNELS** menu opens.



- 3 Press **▲** or **▼** to highlight **Auto Zoom**, then press **◀** or **▶** to select **On**.
- 4 Press **EXIT** to close the menu.

## Checking the DTV signal strength

You can check the DTV signal strength to determine if you need to adjust your antenna or digital cable input. The higher the signal strength, the less likely you are to experience picture degradation.

### To check the DTV signal strength:

- 1 Press **MENU**. The on-screen menu opens.

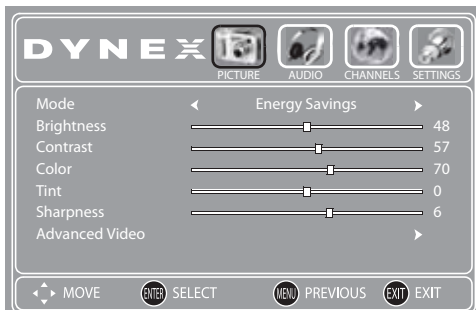

- 2 Press **◀** or **▶** to highlight **CHANNELS**, then press **▼**. The **CHANNELS** menu opens.



- 3 Press **▲** or **▼** to highlight **Channel Strength**, then press **ENTER**. The DTV signal strength is indicated by the color bar.
- 4 Press **EXIT** to close the menu.

## Setting parental controls

Parental controls let you prevent your children from watching inappropriate material on TV. When set, parental controls read the rating of the program (with some exceptions, such as news and sports) and deny access to programs that exceed the ratings level you select. To watch programs that exceed the selected rating, you must enter a password.

*Note: Parental controls are only effective for a TV source.*

## Turning parental controls on or off

### To turn parental controls on or off:

- 1 Press **MENU**. The on-screen menu opens.

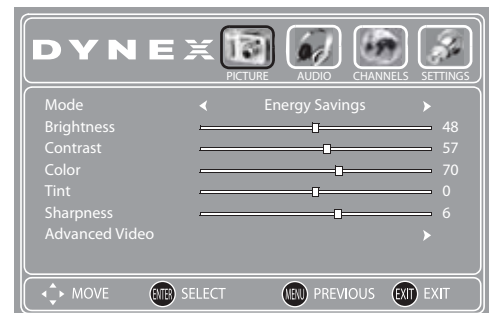

- 2 Press **◀** or **▶** to highlight **SETTINGS**, then press **▼**. The **SETTINGS** menu opens.



- 3 Press **ENTER**. The *Enter Password* screen opens.



- 4 Press the number buttons to enter the four-digit password. The default password is **0000**. The *Parental Controls* sub-menu opens.



- 5 Press **▲** or **▼** to highlight **System Lock**, then press **◀** or **▶** to select **On** (to enable the blocking scheme you set up and to set up the blocking scheme, otherwise the rating setting cannot be accessed) or **Off** (to disable the blocking scheme you set up).
- 6 Press **EXIT** to close the menu.

## Setting or changing the password

To set the parental control password:

- 1 Press **MENU**. The on-screen menu opens.

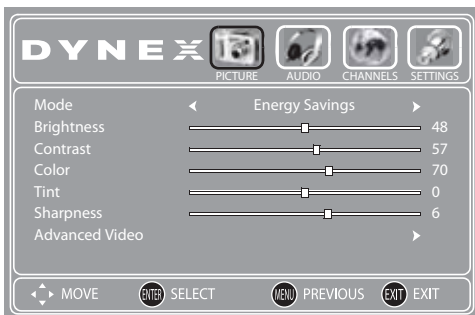

- 2 Press **◀** or **▶** to highlight **SETTINGS**, then press **▼**. The *SETTINGS* menu opens.



- 3 Press **ENTER**. The *Enter Password* screen opens.



- 4 Press the number buttons to enter the four-digit password. The default password is **0000**. The *Parental Controls* sub-menu opens.



- 5 Press **▲** or **▼** to highlight **Change Password**, then press **ENTER**. The *Change Password* screen opens.



- 6 Press the number buttons to enter a new password, then press **▲** or **▼** to highlight **Confirm New Password**.
  - 7 Press the number buttons to enter the new password again to confirm it. The *Parental Controls* sub-menu opens.
- Note:** If you forget your password, enter **9999**.



- 8 Press **EXIT** to close the menu.

## Turning button lock on or off

To turn the parental controls button lock on or off:

- 1 Press **MENU**. The on-screen menu opens.

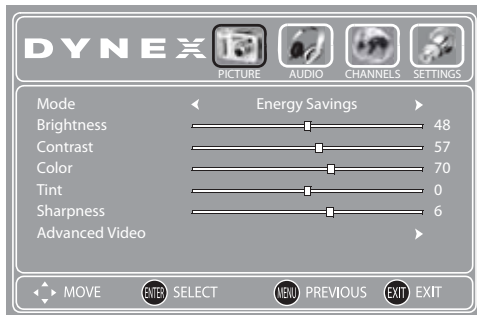

- 2 Press **◀** or **▶** to highlight **SETTINGS**, then press **▼**. The **SETTINGS** menu opens.



- 3 Press **ENTER**. The *Enter Password* screen opens.



- 4 Press the number buttons to enter the four-digit password. The default password is **0000**. The *Parental Controls* sub-menu opens.



- 5 Press **▲** or **▼** to highlight **Button Lock**, then press **◀** or **▶** to select **ON** (to turn the Button Lock on) or **OFF** (to turn the Button Lock off).

- 6 Press **EXIT** to close the menu.

With the Button Lock on, the buttons on the TV control panel are locked. The message "Use remote to enable button" will appear every time you press a button on the TV control panel. Unplug your TV, then reconnect it to turn the Button Lock off.

## Setting parental control levels

You can set parental controls for the U.S. and Canada. The following procedure shows how to set controls for U.S. TV ratings. You use similar steps for controlling U.S. movie and Canadian TV ratings.

To set parental controls:

- 1 Press **MENU**. The on-screen menu opens.

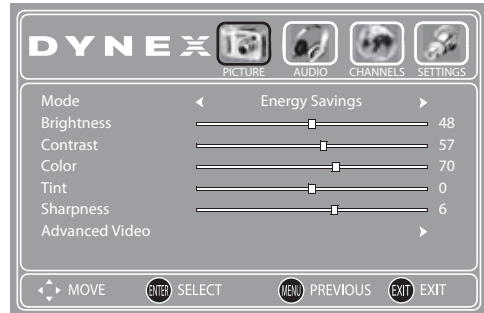

- 2 Press **◀** or **▶** to highlight **SETTINGS**, then press **▼**. The **SETTINGS** menu opens.



- 3 Press **ENTER**. The *Enter Password* screen opens.



- 4 Press the number buttons to enter the four-digit password. The default password is **0000**. The *Parental Controls* sub-menu opens.

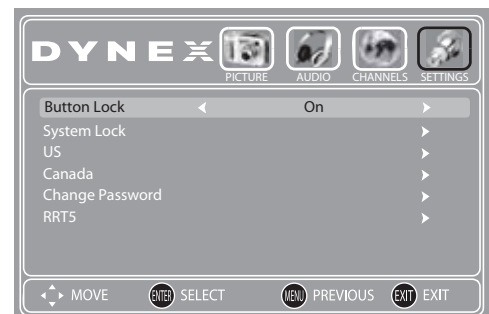

**Note:** If you forget the password, enter **9999**.

- 5 Press **▲** or **▼** to highlight **System Lock**, then press **◀** or **▶** to select **On**.

- 6 Press **▲** or **▼** to highlight **US** (or **Canada** to set controls for Canada), then press **ENTER**.



- 7 Press **▲** or **▼** to highlight **TV**, then press **▶**. The **TV RATING** sub-menu opens.

**Note:** You can also select **MPAA** to set controls for US movie ratings.

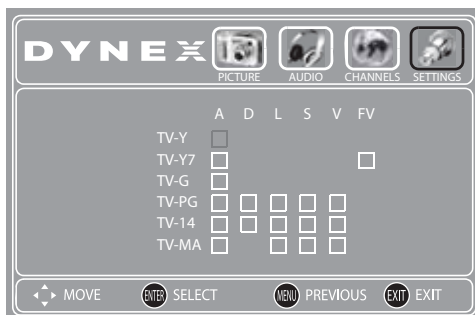

- 8 Press **▲** **▼** **◀** or **▶** to highlight the rating you want to block, then press **ENTER**. A lock symbol appears when a rating is blocked.

**Note:** On the **MPAA RATING** screen, press **▲** or **▼** to select the rating. When a rating is blocked, that rating and all other higher ratings are blocked.

- 9 Press **EXIT** to close the menu.

U. S. TV ratings (age-based)	
TV-Y	All children.
TV-Y7	Suitable for children 7 and older.
TV-G	General audiences.
TV-PG	Parental guidance suggested.
TV-14	Parental guidance strongly suggested.
TV-MA	Mature audiences only.

U. S. TV ratings (content-based)	
ALL	All content based ratings.
FV	Fantasy violence.
V	Violence.
S	Sexual situations.
L	Strong language.
D	Suggestive dialog.

U.S. movie (MPAA) ratings	
N/A	Movie is not rated.
G	General audiences.
PG	Parental guidance suggested.
PG-13	Suitable for children 13 and older.
R	Parental guidance suggested for children under 17.
NC-17	Not suitable for children under 17.
X	Adults only.

Canadian English ratings	
EXEMPT	Exempt programming.
C	Suitable for all children.
C8+	Suitable for children 8 and older.
G	General audiences.
PG	Parental guidance suggested.
14+	Suitable for children 14 and older.
18+	Adults only.

Canadian French ratings	
E	Exempt programming.
G	General audiences.
8 Ans+	Suitable for children 8 and older.
13 Ans+	Suitable for children 13 and older.
16 Ans+	Suitable for children 16 and older.
18 Ans+	Adults only.

### Downloading rating information

You can download rating information to use when setting parental controls.

#### To download rating information:

- 1 Press **MENU**. The on-screen menu opens.

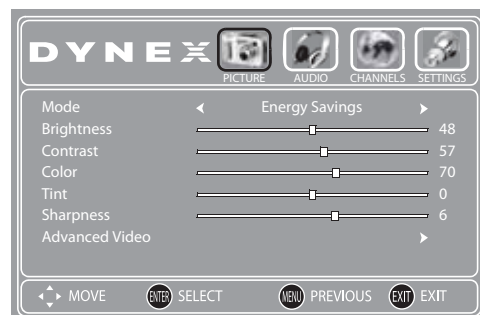

- 2 Press **◀** or **▶** to highlight **SETTINGS**, then press **▼**. The **SETTINGS** menu opens.



- 3 Press **ENTER**. The *Enter Password* screen opens.



- 4 Press the number buttons to enter the four-digit password. The default password is **0000**. The *Parental Controls* sub-menu opens.



- 5 Press **▲** or **▼** to highlight **System Lock**, then press **◀** or **▶** to select **On**.
- 6 Press **▲** or **▼** to highlight **RRT5**, then press **ENTER**. If the program is broadcast with RRT5 rating information, the information is downloaded automatically and can be used for parental controls.



- 2 Press **◀** or **▶** to highlight **SETTINGS**, then press **▼**. The *SETTINGS* menu opens.



- 3 Press **▲** or **▼** to highlight **Time**, then press **ENTER**. The *Time* sub-menu opens.



- 4 Press **▲** or **▼** to highlight **Date/Time**, then press **ENTER**. The *Time Setting* menu opens.



- 5 Press **▲** or **▼** to highlight **Mode**, then press **◀** or **▶** to select **Manual** (to set the date and time manually), or **Auto** (the date and time are automatically set by the TV signal source, based on the time zone you select).
- 6 Press **▲** or **▼** to highlight **Time Zone**, then press **◀** or **▶** to select your time zone. You can select **Pacific, Alaska, Hawaii, Newfoundland, Atlantic, Eastern, Central, or Mountain**.
- 7 If your viewing area observes daylight savings time, press **▲** or **▼** to highlight **Daylight Savings**, then press **◀** or **▶** to select **On**.
- 8 If you select **Manual** mode, make the settings as follows:
- Press **▲** or **▼** to highlight **Year, Month, or Day**, then press **◀** or **▶** to adjust the setting.
  - Set the time by pressing **▲** or **▼** to highlight **Time**, then press **◀** or **▶** to highlight the hour, minute, or AM/PM field. Press **▲** or **▼** to adjust the setting.
- 9 Press **EXIT** to close the menu.

## Adjusting time settings

### Setting the date and time

To set the date and time:

- 1 Press **MENU**. The on-screen menu opens.

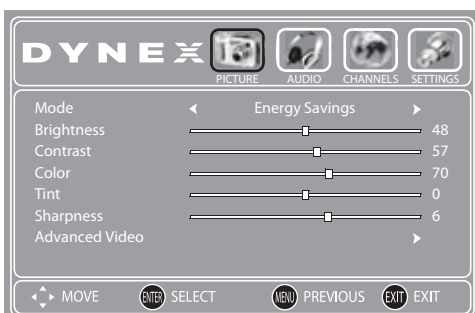

## Setting the sleep timer

You can specify the amount of time before your TV automatically turns off.

### To set the sleep timer:

- 1 Press **MENU**. The on-screen menu opens.

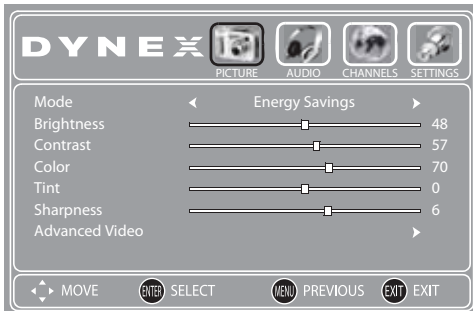

- 2 Press **◀** or **▶** to highlight **SETTINGS**, then press **▼**. The **SETTINGS** menu opens.



- 3 Press **▲** or **▼** to highlight **Time**, then press **ENTER**. The **Time** sub-menu opens.



- 4 Press **▲** or **▼** to highlight **Sleep Timer**, then press **◀** or **▶** to select the amount of time you want your TV to stay on before it automatically turns off.

**Note:** Select **Off** to turn the Sleep Timer off.

- 5 Press **EXIT** to close the menu.

**Note:** You can also press **SLEEP** on the remote control to set the sleep timer.

## Using closed captioning

### Selecting the closed captioning mode

#### To select the closed captioning mode:

- 1 Press **MENU**. The on-screen menu opens.

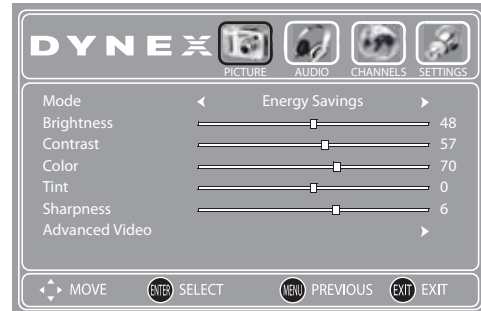

- 2 Press **◀** or **▶** to highlight **SETTINGS**, then press **▼**. The **SETTINGS** menu opens.



- 3 Press **▼** to highlight **Closed Caption**, then press **ENTER**. The **Closed Caption Setup** screen opens.



- 4 Press **▼** to highlight **Caption Control**, then press **◀** or **▶** to select the CC Mode. You can select:

- **CC On**—Turns on closed captioning
- **CC On When Mute**—Turns on closed captioning when the sound is muted.
- **CC Off**—Turns off closed captioning.

- 5 Press **EXIT** to close the menu.

**Note:** You can also press **CCD** on the remote control to turn closed captioning on or off.

## Selecting the closed captioning type

To select the closed captioning type:

- 1 Press **MENU**. The on-screen menu opens.

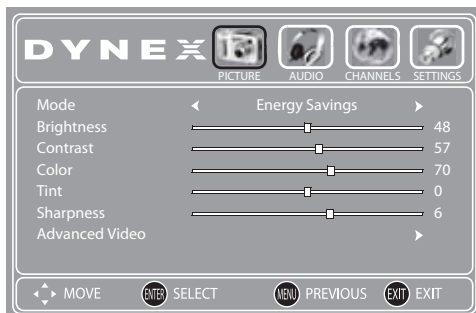

- 2 Press **◀** or **▶** to highlight **SETTINGS**, then press **▼**. The **SETTINGS** menu opens.



- 3 Press **▼** to highlight **Closed Caption**, then press **ENTER**. The **Closed Caption Setup** screen opens.

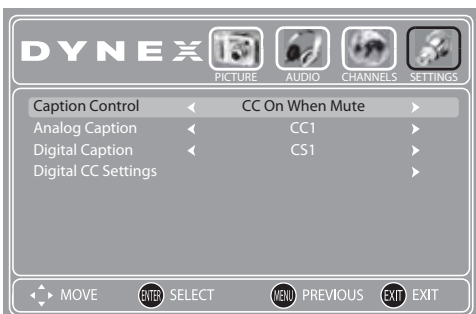

- 4 Press **▼** to highlight **Caption Control**, press **◀** or **▶** to set the CC mode to **On**.
- 5 Press **▲** or **▼** to highlight **Analog Caption**.

**Note:** If the channel is analog, Analog Caption will be available and the Digital Caption will be grayed out (inactive).

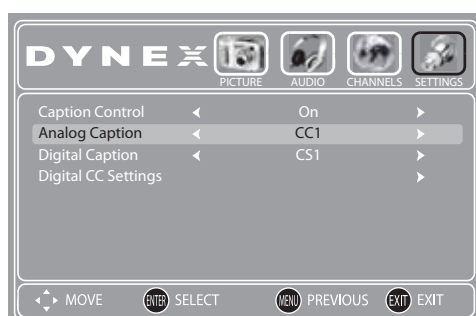

- 6 Press **◀** or **▶** to select a closed captioning mode. You can select:

- **CC1** through **CC4**—Closed captioning appears in a small banner across the bottom of the screen. **CC1** is usually the “printed” version of the audio. **CC2** through **CC4** display content provided by the broadcaster.
- **Text1** through **Text4**—Closed captioning that covers half or all of the screen. **Text1** through **Text4** display content provided by the broadcaster.

- 7 Press **EXIT** to close the menu.

## Customizing digital TV closed captioning styles

To customize DTV closed captioning:

- 1 Press **MENU**. The on-screen menu opens.

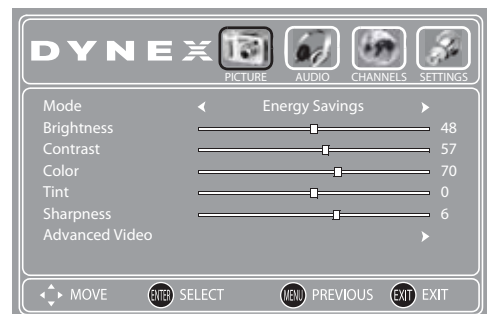

- 2 Press **◀** or **▶** to highlight **SETTINGS**, then press **▼**. The **SETTINGS** menu opens.



- 3 Press **▼** to highlight **Closed Caption**, then press **ENTER**. The **Closed Caption Setup** screen opens.



- 4 Press **▼** to highlight **Caption Control**, press **◀** or **▶** to set the CC mode to **On**.



- 5 Press **▲** or **▼** to highlight **Digital Caption** (only available for digital stations), then press **▲** or **▼** to select an advanced closed captioning option. You can select **CS1-CS6** (displays content provided by broadcaster).

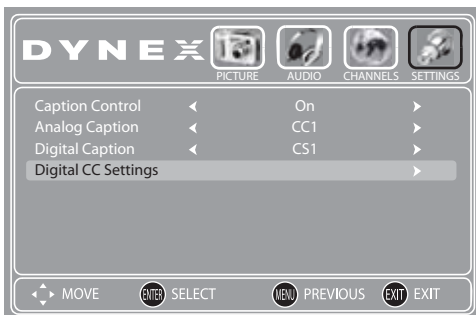

- 6 Press **▲** or **▼** to highlight **Digital CC Settings**, then press **ENTER**. The DTV closed captioning styles menu opens.

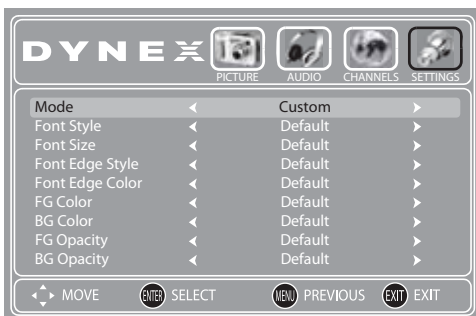

- 7 Press **▲** or **▼** to highlight **Style**, then press **◀** or **▶** to select **Custom**.

**Note:** To reset the closed captioning styles to their defaults, set **Style** to **Default**.

- 8 Press **▲** or **▼** to highlight a style, then press **◀** or **▶** adjust the style. You can select:
- **Size**—To select a size for the words.
  - **Font**—To select a font for the words.
  - **Text Color**—To select a color for the text.
  - **Text Opacity**—To select the opacity for the text.
  - **Background Color**—To select a color for the background.
  - **Background Opacity**—To select the opacity for the background.
  - **Edge Effect**—To select an effect for the edges.
- 9 Press **EXIT** to close the menu.

## Adjusting menu settings

### Selecting the menu language

To select the on-screen menu language:

- 1 Press **MENU**. The on-screen menu opens.

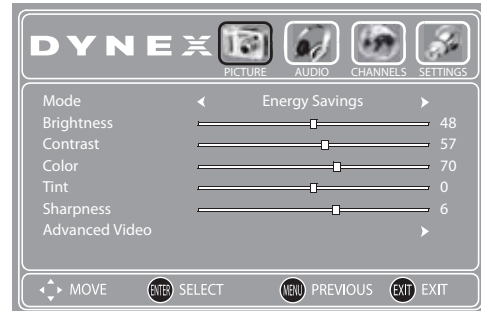

- 2 Press **◀** or **▶** to highlight **SETTINGS**, then press **▼**. The **SETTINGS** menu opens.



- 3 Press **▲** or **▼** to highlight **Language**, then press **◀** or **▶** to select the menu language you want. Options include **English**, **French**, and **Spanish**.
- 4 Press **EXIT** to close the menu.

### Labeling an input source

You can add a label to an input source to make it easier to identify.

To label an input source:

- 1 Press **MENU**. The on-screen menu opens.

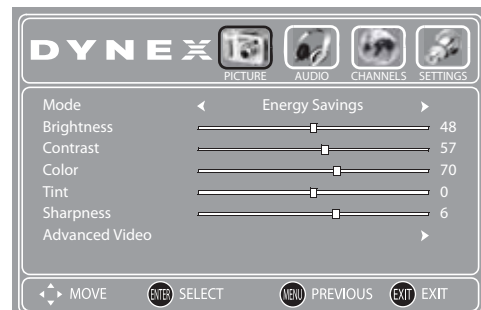

- 2 Press **◀** or **▶** to highlight **SETTINGS**, then press **▼**. The **SETTINGS** menu opens.



- 3 Press **▲** or **▼** to highlight **Input Labels**, then press **ENTER**. The **Input Labels** screen opens.

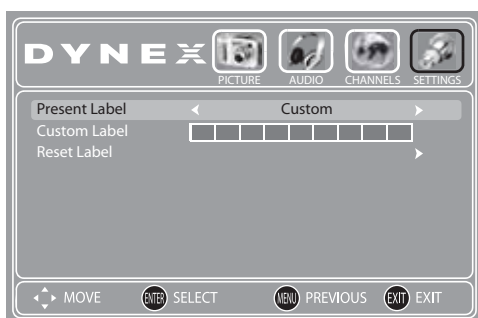

- 4 Press **◀** or **▶** to highlight a preset label from several options, or select **Custom** to enter your own label.
- 5 If you select **Custom**, press **▲** or **▼** to highlight **Custom Label**, then press **ENTER**.
- 6 Press **▲** or **▼** to select a character, then press **◀** or **▶** to move to the next position. Repeat this step to add more characters.
- 7 To reset the label to factory default, press **▲** or **▼** to highlight **Reset Label**, then press **ENTER**.
- 8 Press **EXIT** to close the menu. The next time you press the **INPUT** button on the remote control, you will see your new label in the **INPUT SOURCE** menu.

## Restoring default settings

**Caution:** When you restore default settings, all the settings (except the password and parental rating) you have customized are reset.

### To restore default settings:

- 1 Press **MENU**. The on-screen menu opens.

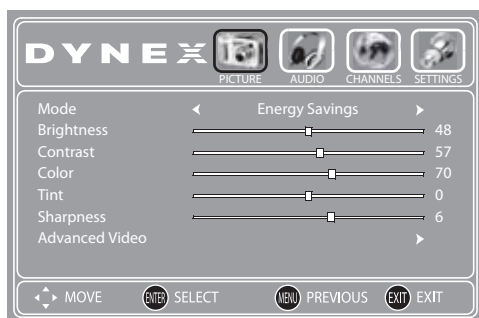

- 2 Press **◀** or **▶** to highlight **SETTINGS**, then press **▼**. The **SETTINGS** menu opens.



- 3 Press **▲** or **▼** to highlight **Reset to Default**, then press **ENTER**. A confirmation box opens.
- 4 Press **◀** or **▶** to select **Yes**, then press **ENTER**.
- 5 Press **EXIT** to close the menu.

## Troubleshooting

**Warning:** Do not try to repair your TV yourself. Contact authorized service personnel.

### Video and audio

Problem	Solution
No picture (screen is not lit) and no sound.	<ul style="list-style-type: none"> <li>• Make sure that the power cord is plugged in.</li> <li>• Press <b>POWER</b>  on the TV or the remote control.</li> <li>• Make sure that the correct video input source is selected. For more information, see "Selecting the video input source" on page 11.</li> <li>• Try another channel. The station may be experiencing problems.</li> </ul>
Dark, poor, or no picture (screen is lit), but sound is good.	<ul style="list-style-type: none"> <li>• Adjust the brightness. For more information, see "Adjusting the TV picture" on page 13.</li> <li>• Make sure that the correct picture mode is selected. For more information, see "Adjusting the TV picture" on page 13.</li> <li>• Make sure that the antenna or cable TV is connected correctly and securely. For more information, see "Connecting an antenna, cable TV, or satellite TV box" on page 8.</li> </ul>
No color, dark picture, or color is not correct.	<ul style="list-style-type: none"> <li>• Adjust the color saturation. For more information, see "Adjusting the TV picture" on page 13.</li> </ul>
Only snow (noise) appears on the screen.	<ul style="list-style-type: none"> <li>• Try another channel. The station may be experiencing problems.</li> <li>• Make sure that the antenna or cable TV is connected correctly and securely. For more information, see "Connecting an antenna, cable TV, or satellite TV box" on page 8.</li> <li>• Check the signal strength of the channel. See "Checking the DTV signal strength" on page 17.</li> </ul>
Dotted lines or stripes appear on the screen.	<ul style="list-style-type: none"> <li>• Adjust the antenna.</li> <li>• Move the TV away from noise sources such as cars, neon signs, or hair dryers.</li> </ul>
Double images.	<ul style="list-style-type: none"> <li>• Use a highly directional outdoor antenna or cable TV.</li> </ul>

Problem	Solution
The picture has a few bright or dark spots.	<ul style="list-style-type: none"> <li>A few bright or dark spots on an LCD screen is normal. It does not affect the operation of this TV.</li> </ul>
Good picture, but no sound.	<ul style="list-style-type: none"> <li>Make sure that the sound is not muted.</li> <li>Make sure that the sound mode is set to <b>Stereo</b> or <b>Mono</b>. For more information, see "Adjusting sound settings" on page 14.</li> </ul>
Audio noise.	<ul style="list-style-type: none"> <li>Make sure that there is no interference with infrared equipment such as a cordless telephone or headphones. Move the infrared equipment away from the TV to eliminate the noise.</li> </ul>

## Remote control

Problem	Solution
Remote control does not work.	<ul style="list-style-type: none"> <li>Make sure that the power cord is plugged in.</li> <li>Make sure that there are no obstructions between the remote control and the remote control sensor on the front of the TV.</li> <li>Make sure that the batteries are installed correctly. For more information, see "Installing remote control batteries" on page 6.</li> <li>Replace the batteries. For more information, see "Installing remote control batteries" on page 6.</li> </ul>
Trouble programming your existing universal remote control.	<ul style="list-style-type: none"> <li>See instructions and a table of common codes in "Programming a universal remote control to work with your TV" on page 7.</li> <li>Codes are subject to change. For up to date codes, go to <a href="http://www.dynexproducts.com">www.dynexproducts.com</a>.</li> <li>Replace the batteries. For more information, see "Installing remote control batteries" on page 6.</li> <li>Refer to the User Guide that accompanied your universal remote control and contact the manufacturer if problems persist</li> </ul>

## General

Problem	Solution
One or more channels do not display.	<ul style="list-style-type: none"> <li>Make sure that the channels are not blocked. For more information, see "Setting parental control levels" on page 19.</li> <li>Make sure that the channels are not hidden. For more information, see "Hiding channels" on page 15.</li> <li>The channel may have been deleted from the channel list. You can tune to the channel by pressing the number buttons or you can add the channel back to the channel list. For more information, see "Changing channel settings" on page 15.</li> </ul>
Password is lost.	<ul style="list-style-type: none"> <li>Enter <b>9999</b> to access parental controls, then set a new password. For more information, see "Setting parental control levels" on page 19.</li> </ul>

Problem	Solution
Some settings cannot be accessed.	<ul style="list-style-type: none"> <li>If a setting is grayed, the setting is not available in the current video input mode.</li> </ul>
TV cabinet creaks.	<ul style="list-style-type: none"> <li>When the TV is in use, the temperature rises naturally and may cause the cabinet to expand or contract which can cause a creaking noise. This is not a malfunction.</li> </ul>
Control buttons on the TV do not work.	<ul style="list-style-type: none"> <li>Disconnect the power cord, wait a few seconds, then reconnect the power cord and turn on the TV.</li> </ul>

*Note: If the problem is not solved by using these troubleshooting instructions, turn off your TV, then turn it on again.*

## Maintenance

### Cleaning

- Clean your TV with a soft, dry cloth. If surfaces are extremely dirty, use a soft cloth dampened with a weak detergent solution.
- Use an eyeglass cleaner to clean the screen. Never use alcohol, paint thinner, or benzine.
- Before using a chemically treated cloth, read the instructions that came with the cloth.

## Specifications

Design and specifications are subject to change without notice. Dimensions and weight are approximate.

<b>TV type</b>	LCD
<b>TV panel</b>	32-inch TFT LCD
<b>TV system</b>	NTSC-M, ATSC
<b>Channels</b>	VHF: 2 - 13 UHF: 14 - 69 CATV: 1 - 125 CADTV: 1-135 DTV: 2 - 69
<b>Audio multiplex</b>	BTSC system
<b>Audio output</b>	8.4W × 2
<b>Power requirement</b>	AC 120 V, 60 Hz
<b>Power consumption</b>	110 W
<b>Dimensions (WxHxD with stand)</b>	30.7 x 21.2 x 8.3 inches (779.8 x 538.5 x 210.8 mm)
<b>Weight</b>	20.7 lbs (9.4 kg)
<b>Input terminals</b>	Composite (AV) video/left and right audio (1) Component video/left and right audio (1) HDMI (2) VGA/audio (1) Antenna (1)
<b>Output terminals</b>	Headphone jack (1) Digital optical audio (1)
<b>Control terminals</b>	Service Port (1)

## Legal notices

### FCC Part 15

This device complies with Part 15 of the FCC Rules. Operation of this product is subject to the following two conditions: (1) this device may not cause harmful interference, and (2) this device must accept any interference received, including interference that may cause undesired operation.

This equipment has been tested and found to comply within the limits for a class B digital device, pursuant to Part 15 of the FCC Rules. These limits are designed to provide reasonable protection against harmful interference in a residential installation. This equipment generates, uses, and can radiate radio frequency energy and, if not installed and used in accordance with the instructions, may cause harmful interference to radio communications. However, there is no guarantee that interference will not occur in a particular installation. If this equipment does cause harmful interference to radio or television reception, which can be determined by turning the equipment off and on, the user is encouraged to try to correct the interference by one or more of the following measures:

- Reorient or relocate the receiving antenna.
- Increase the separation between the equipment and receiver.
- Connect the equipment into an outlet on a circuit different from that to which the receiver is connected.
- Consult the dealer or an experienced technician for help.

### FCC warning

Changes or modifications not expressly approved by the party responsible for compliance with the FCC Rules could void the user's authority to operate this equipment.

### Cables

Connections to this device must be made with shielded cables with metallic RF/EMI connector hoods to maintain compliance with FCC Rules and Regulations.

### Canada ICES-003 statement

This Class B digital apparatus complies with Canadian ICES-003.

Cet appareil numérique de la classe B est conforme à la norme NMB-003 du Canada.

Standard Television Receiving Apparatus — Appareil de réception télévision ordinaire, Canada BETS-7 / NTMR-7

### HDMI

# HDMI®

HIGH-DEFINITION MULTIMEDIA INTERFACE

HDMI, the HDMI logo, and High-Definition Multimedia Interface are trademarks or registered trademarks of HDMI Licensing LLC.

### Energy Star



Please keep the factory default settings as shipped, in which the product can meet Energy Star requirements.

### Dolby Laboratories



Manufactured under license from Dolby Laboratories. Dolby and the double-D symbol are trademarks of Dolby Laboratories.



# One-year limited warranty

## US and Canada Markets

### Definitions:

Dynex Products ("Dynex") warrants to you, the original purchaser of this new Dynex-branded television ("Product"), that the Product shall be free of defects in the original manufacturer of the material or workmanship for a period of one (1) year from the date of your purchase of the Product ("Warranty Period"). For this warranty to apply, your Product must be purchased in the United States or Canada from a Best Buy or Future Shop authorized dealer of Dynex brand products only that are packaged with this warranty statement.

### How long does the coverage last?

The Warranty Period lasts for 1 year (365 days) from the date you purchased the Product. Your purchase date is printed on the receipt you received with the Product.

### What does this warranty cover?

During the Warranty Period, if the original manufacture of the material or workmanship of the Product is determined to be defective by an authorized Dynex repair center or store personnel, Dynex will (at its sole option): (1) repair the Product with new or rebuilt parts; or (2) replace the Product at no charge with new or rebuilt comparable products or parts. Products and parts replaced under this warranty become the property of Dynex and are not returned to you. If service of Products or parts are required after the Warranty Period expires, you must pay all labor and parts charges. This warranty lasts as long as you own your Dynex Product during the Warranty Period. Warranty coverage terminates if you sell or otherwise transfer the Product.

### How to obtain warranty service?

If you purchased the Product at a Best Buy or Future Shop retail store location and your television Product has a screen size of less than 37 inches, please take your original receipt and the Product to any Best Buy or Future Shop store. Make sure that you place the Product in its original packaging or packaging that provides the same amount of protection as the original packaging. If you purchased the Product from a Best Buy or Future Shop online web site, mail your original receipt and the Product to the address listed on the web site. Make sure that you put the Product in its original packaging or packaging that provides the same amount of protection as the original packaging. To obtain in-home warranty service for a television with a screen 37 inches or larger, in the United States call 1-888-BESTBUY, Canada call 1-866-BESTBUY for Future Shop call 1-800-663-2275. Call agents will diagnose and correct the issue over the phone or will have a Dynex-approved repair technician dispatched to your home.

### Where is the warranty valid?

This warranty is valid only to the original purchaser of the product in the United States and Canada at Best Buy or Future Shop branded retail stores or websites.

### What does the warranty not cover?

This warranty does not cover:

- Customer instruction/education
- Installation
- Set up adjustments
- Cosmetic damage
- Damage due to acts of God, such as power surges
- Accident(s)
- Misuse
- Abuse
- Negligence
- Commercial purposes/use, including but not limited to use in a place of business or in communal areas of a multiple dwelling condominium or apartment complex, or otherwise used in a place of other than a private home.
- Modification of any part of the Product, including the antenna
- Plasma display panel damaged by static (non-moving) images applied for lengthy periods (burn-in).
- Damage due to incorrect operation or maintenance
- Connection to an incorrect voltage or power supply
- Attempted repair by any person not authorized by Dynex to service the Product
- Products sold "as is" or "with all faults"
- Consumables, including but not limited to batteries (i.e. AA, AAA, C etc.)
- Products where the factory applied serial number has been altered or removed
- Loss or Theft of this product or any part of the product

REPAIR REPLACEMENT AS PROVIDED UNDER THIS WARRANTY IS YOUR EXCLUSIVE REMEDY FOR BREACH OF WARRANTY. DYNEX SHALL NOT BE LIABLE FOR ANY INCIDENTAL OR CONSEQUENTIAL DAMAGES FOR THE BREACH OF ANY EXPRESS OR IMPLIED WARRANTY ON THIS PRODUCT, INCLUDING, BUT NOT LIMITED TO, LOST DATA, LOSS OF USE OF YOUR PRODUCT, LOST BUSINESS OR LOST PROFITS. DYNEX PRODUCTS MAKES NO OTHER EXPRESS WARRANTIES WITH RESPECT TO THE PRODUCT, ALL EXPRESS AND IMPLIED WARRANTIES FOR THE PRODUCT, INCLUDING, BUT NOT LIMITED TO, ANY IMPLIED WARRANTIES OF AND CONDITIONS OF MERCHANTABILITY AND FITNESS FOR A PARTICULAR PURPOSE, ARE LIMITED IN DURATION TO THE WARRANTY PERIOD SET FORTH ABOVE AND NO WARRANTIES, WHETHER EXPRESS OR IMPLIED, WILL APPLY AFTER THE WARRANTY PERIOD. SOME STATES, PROVINCES AND JURISDICTIONS DO NOT ALLOW LIMITATIONS ON HOW LONG AN IMPLIED WARRANTY LASTS, SO THE ABOVE LIMITATION MAY NOT APPLY TO YOU. THIS WARRANTY GIVES YOU SPECIFIC LEGAL RIGHTS, AND YOU MAY ALSO HAVE OTHER RIGHTS, WHICH VARY FROM STATE TO STATE OR PROVINCE TO PROVINCE.

Contact Dynex:

For customer service please call 1-800-305-2204

www.Dynexproducts.com

Distributed by Best Buy Purchasing, LLC

7601 Penn Avenue South, Richfield, Minnesota, U.S.A. 55423-3645

© 2010 BBY Solutions, Inc.

All rights reserved. DYNEX is a trademark of BBY Solutions, Inc. Registered in some countries. All other products and brand names are trademarks of their respective owners.

## Mexico Market

{RETAILER SEAL}

PLACE STICKER OF PRODUCT MAKE & MODEL HERE

DATE OF PURCHASE: \_\_\_\_\_

### Definitions:

Dynex Products ("Dynex") warrants to you, the original purchaser of this new Dynex-branded television ("Product"), that the Product shall be free of defects in the original manufacturer of the material or workmanship for a period of one (1) year from the date of your purchase of the Product ("Warranty Period"). For this warranty to apply, your Product must be purchased in Mexico from a Best Buy authorized dealer of Dynex brand products only that are packaged with this warranty statement.

### How long does the coverage last?

The Warranty Period lasts for 1 year (365 days) from the date you purchased the Product. Your purchase date is printed on the receipt you received with the Product.

### What does this warranty cover?

During the Warranty Period, if the original manufacture of the material or workmanship of the Product is determined to be defective by an authorized Dynex repair center or store personnel, Dynex will (at its sole option): (1) repair the Product with new or rebuilt parts; or (2) replace the Product at no charge with new or rebuilt comparable products or parts. Products and parts replaced under this warranty become the property of Dynex and are not returned to you. If service of Products or parts are required after the Warranty Period expires, you must pay all labor and parts charges. This warranty lasts as long as you own your Dynex Product during the Warranty Period. Warranty coverage terminates if you sell or otherwise transfer the Product.

### How to obtain warranty service?

If you purchased the Product at a Best Buy retail store location and your television Product has a screen size of less than 37 inches, please take your original receipt and the Product to any Best Buy store. Make sure that you place the Product in its original packaging or packaging that provides the same amount of protection as the original packaging. If you purchased the Product from a Best Buy online web site, mail your original receipt and the Product to the address listed on the web site. Make sure that you put the Product in its original packaging or packaging that provides the same amount of protection as the original packaging.

To obtain in-home warranty service for a television with a screen 37 inches or larger, in Mexico call 01 800-433-5778. Call agents will diagnose and correct the issue over the phone or will have a Dynex-approved repair technician dispatched to your home.

### Where is the warranty valid?

This warranty is valid only to the original purchaser of the product in Mexico at a Best Buy branded retail stores or website.

### **What does the warranty not cover?**

This warranty does not cover:

- Customer instruction/education
- Installation
- Set up adjustments
- Cosmetic damage
- Damage due to acts of God, such as power surges
- Accident(s)
- Misuse
- Abuse
- Negligence
- Commercial purposes/use, including but not limited to use in a place of business or in communal areas of a multiple dwelling condominium or apartment complex, or otherwise used in a place of other than a private home.
- Modification of any part of the Product, including the antenna
- Plasma display panel damaged by static (non-moving) images applied for lengthy periods (burn-in).
- Damage due to incorrect operation or maintenance
- Connection to an incorrect voltage or power supply
- Attempted repair by any person not authorized by Dynex to service the Product
- Products sold "as is" or "with all faults"
- Consumables, including but not limited to batteries (i.e. AA, AAA, C etc.)
- Products where the factory applied serial number has been altered or removed
- Loss or Theft of this product or any part of the product

REPAIR REPLACEMENT AS PROVIDED UNDER THIS WARRANTY IS YOUR EXCLUSIVE REMEDY FOR BREACH OF WARRANTY. DYNEX SHALL NOT BE LIABLE FOR ANY INCIDENTAL OR CONSEQUENTIAL DAMAGES FOR THE BREACH OF ANY EXPRESS OR IMPLIED WARRANTY ON THIS PRODUCT, INCLUDING, BUT NOT LIMITED TO, LOST DATA, LOSS OF USE OF YOUR PRODUCT, LOST BUSINESS OR LOST PROFITS. DYNEX PRODUCTS MAKES NO OTHER EXPRESS WARRANTIES WITH RESPECT TO THE PRODUCT, ALL EXPRESS AND IMPLIED WARRANTIES FOR THE PRODUCT, INCLUDING, BUT NOT LIMITED TO, ANY IMPLIED WARRANTIES OF AND CONDITIONS OF MERCHANTABILITY AND FITNESS FOR A PARTICULAR PURPOSE, ARE LIMITED IN DURATION TO THE WARRANTY PERIOD SET FORTH ABOVE AND NO WARRANTIES, WHETHER EXPRESS OR IMPLIED, WILL APPLY AFTER THE WARRANTY PERIOD. SOME STATES, PROVINCES AND JURISDICTIONS DO NOT ALLOW LIMITATIONS ON HOW LONG AN IMPLIED WARRANTY LASTS, SO THE ABOVE LIMITATION MAY NOT APPLY TO YOU. THIS WARRANTY GIVES YOU SPECIFIC LEGAL RIGHTS, AND YOU MAY ALSO HAVE OTHER RIGHTS, WHICH VARY FROM STATE TO STATE OR PROVINCE TO PROVINCE.

Contact Dynex:

For service, please call 01 800-926-3020

[www.dynexproducts.com](http://www.dynexproducts.com)

Distributed by Best Buy Imports, S. de R.L. de C.V.

Av. Santa Fe 485, Segundo Piso,

Colonia Cruz Manca,

Programa Parcial de Desarrollo Santa Fe,

Delegación Cuajimalpa, Distrito

Federal, México 05349

RFC#BBI0802114Q2

© 2010 BBY Solutions, Inc.

All rights reserved. DYNEX is a trademark of BBY Solutions, Inc. Registered in some countries. All other products and brand names are trademarks of their respective owners.

**DYNEX™**

If the power cord has been damaged, it should be replaced by the manufacturer, your service provider or qualified personnel to avoid risks.

Si el cordón de alimentación es dañado, este debe ser remplazado por el fabricante o su agente de servicio o por personal calificado para evitar el riesgo.

[www.dynexproducts.com](http://www.dynexproducts.com)

US and Canada Market - (800) 305-2204

Mexico Market - 01 800-926-3020

Distributed by Best Buy Purchasing, LLC

7601 Penn Ave. South, Richfield, MN 55423 U.S.A.

© 2010 BBY Solutions, Inc. All rights reserved.

DYNEX is a trademark of BBY Solutions, Inc. Registered in some countries. All other products and brand names are trademarks of their respective owners.

Best Buy Imports, S. de R.L. de C.V. Av. Santa Fe 485, Segundo Piso, Colonia Cruz Manca, Programa Parcial de Desarrollo Santa Fe, Delegación Cuajimalpa, Distrito Federal, México 05349

RFC#BBI0802114Q2

10-1312  
ENGLISH



Se incluye el manual. Favor de leer este manual antes de usar el producto.

Para el Soporte técnico de Dynex en México,

favor llame al: 01 800-926-3020 <http://www.dynexproducts.com>