

BI-48SID/S



FEATURES

Monitor and control remotely with Wi-Fi connectivity

Preserves refrigerated foods with cool, moist air and frozen foods with frigid, dry air

Fight spoilage and odors with a NASA-inspired air purification system

Locks in cold air to ensure freshness with magnetic door seals

Keeps produce fresher with high-humidity, sealed crisper and deli drawers

Controls temperature within one degree of setpoint

Filters water and ice, removing contaminants, chlorine taste, and odor

Delivers fresh, filtered water through an internal dispenser designed to discreetly rest within the refrigerator

Yields ice automatically and "max ice" for additional production

Ensures excellent visibility with bright lights

Refer to freshness cards for tips on food preservation, use, and care

ACCESSORIES

48" Stainless Steel Kickplate

90° Door Stop

Air Purification Cartridge

Egg Container

Stainless Steel Pro Louvered Grille - 84"

Stainless Steel Pro Louvered Grille - 84"

Stainless Steel Pro Louvered Grille - 88"

Stainless Steel Side Panel

Water Filter

White Side Panel

Accessories are available through an authorized dealer.
For local dealer information, visit subzero-wolf.com/locator.



HANDLE OPTIONS

PRO



TUBULAR



PRODUCT DETAILS

REFRIGERATOR

- 1 adjustable dairy compartment
- 1 high-humidity crisper drawer with adjustable dividers
- 2 refrigerator storage drawers with adjustable dividers
- 5 refrigerator door bins (3 adjustable; 2 stationary)
- 5 glass refrigerator shelves (4 adjustable; 1 stationary)
- Internal water dispenser
- LED refrigerator and freezer lights

FREEZER

- 3 freezer storage drawers
- 4 wire freezer shelves (3 adjustable; 1 stationary)

PRODUCT SPECIFICATIONS

Model	BI-48SID/S
Dimensions	48"W x 84"H x 24"D
Door Clearance	30"
Weight	656 lbs
Refrigerator Capacity	18.6 cu. ft.
Freezer Capacity	9.6 cu. ft.
Electrical Supply	115 VAC, 60 Hz
Electrical Service	15 amp dedicated circuit
Plumbing Supply	1/4" OD copper, braided stainless steel or PEX tubing
Plumbing Pressure	35–120 psi
Receptacle	3-prong grounding-type

ELECTRICAL

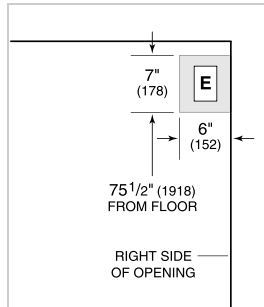

PLUMBING

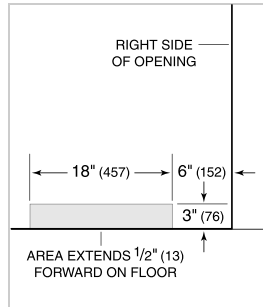

NOTE: Dimensions in parenthesis are in millimeters unless otherwise specified

INTERIOR VIEW



This illustration is intended for interior reference only and may not represent the exterior of the model being specified.

DIMENSIONS

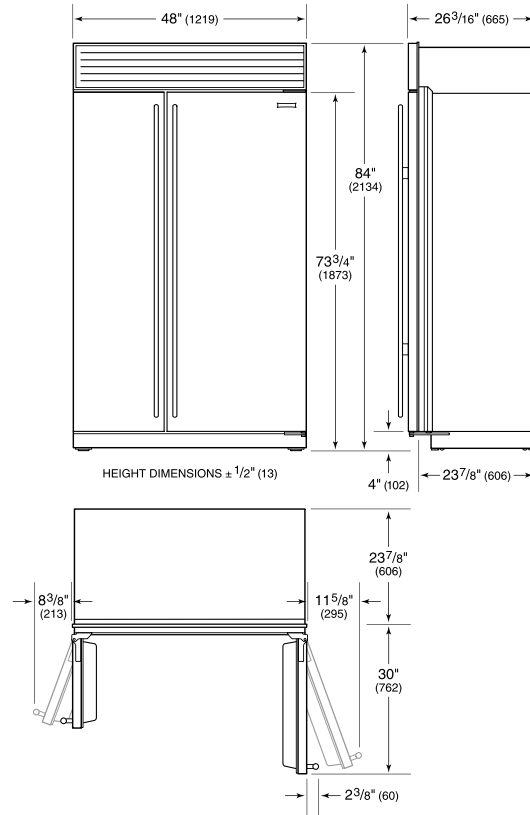

STANDARD INSTALLATION

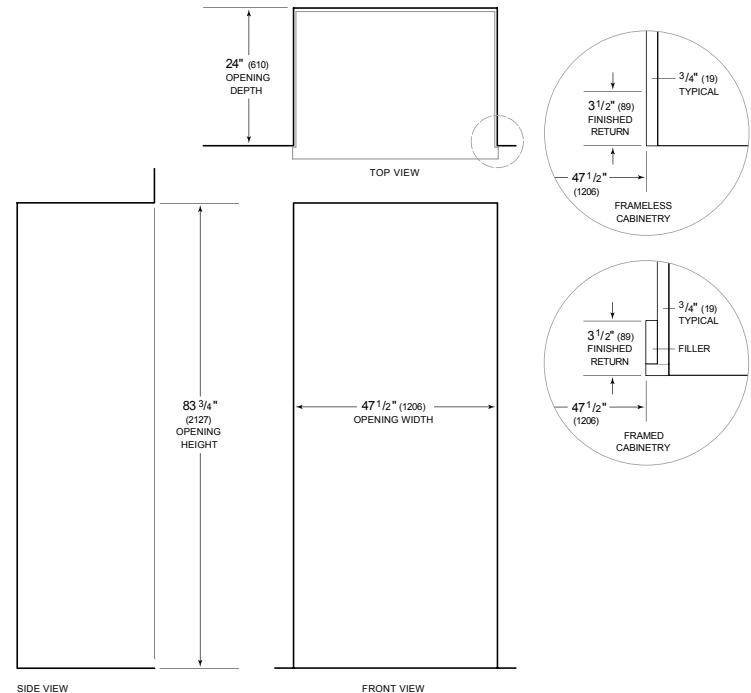

NOTE: 3 1/2" (89) finished returns will be visible and should be finished to match cabinetry. Shaded line represents profile of unit.