



Toyota Corolla 2020-Up, Corolla Hatchback 2019-Up

Visit MetraOnline.com for more detailed information about the product and up-to-date vehicle specific applications

KIT FEATURES

- Designed specifically for the Pioneer DMH-C5500NEX 8-inch radio
- Painted high gloss black to match the factory finish

KIT COMPONENTS

A) Trim panel • B) Trim panel clip brackets • C) Radio brackets • D) Pioneer adapter brackets • E) Panel clips (qty. 2) • F) Phillips screws (qty. 4)

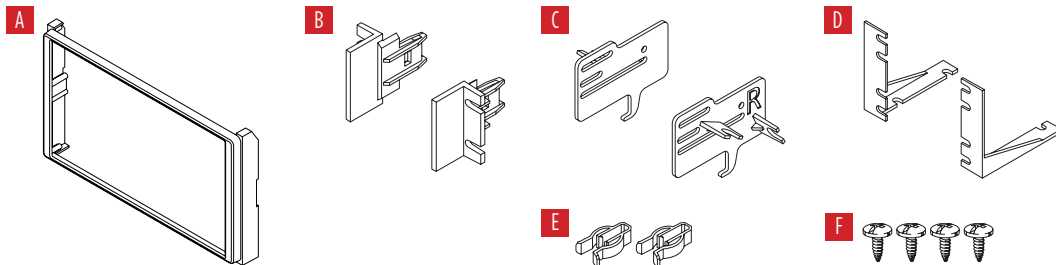

TABLE OF CONTENTS

Dash Disassembly	2
Kit Assembly	3

WIRING & ANTENNA CONNECTIONS (sold separately)

Wiring Harness: 70-1765

Antenna Adapter: 40-LX11

Steering wheel control interface: ASWC-1

12v-to-6v camera step-down: AX-CAM6V

TOOLS REQUIRED

- Panel removal tool • Phillips screwdriver
- 10mm socket wrench

Attention! Let the vehicle sit with the key out of the ignition for a few minutes before removing the factory radio. When testing the aftermarket equipment, ensure that all factory equipment is connected before cycling the key to ignition.

DASH DISASSEMBLY

1. Unclip and remove the radio trim panel. (Figure A)
2. Unclip, unplug, and remove the climate control panel. (Figure B)
3. Unclip, unplug, and remove the center a/c vent and hazard switch assembly. (Figure C)

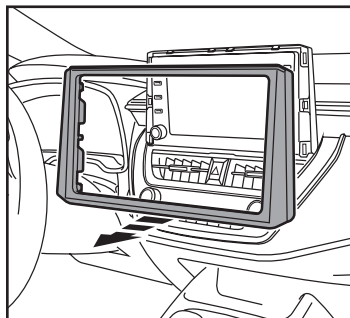

(Figure A)

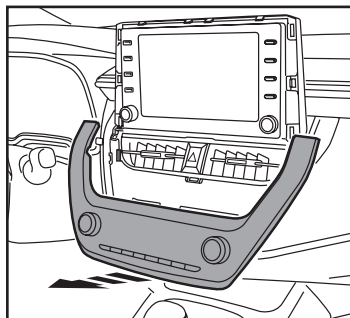

(Figure B)

4. Remove (4) 10mm screws securing the bottom of the radio. Two screws will be clearly visible, but two will be hidden, facing upward. Unclip and slide the radio out, then unplug and remove. (Figure D)

Continue to Kit Assembly

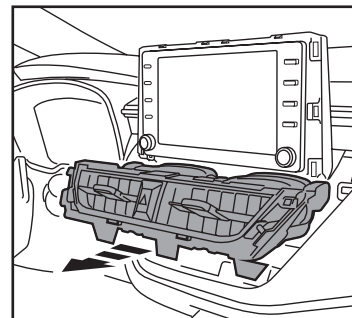

(Figure C)

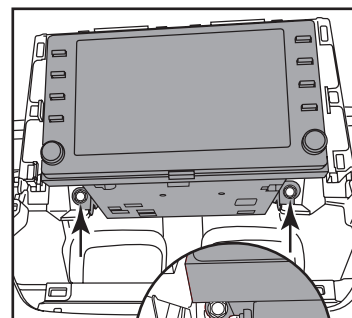

(Figure D)

KIT ASSEMBLY

Note: For steps 1 and 2, reference the installation manual provided with the radio for which hardware to use. The display screen and radio chassis use two different types of screws.

1. Secure the **Pioneer adapter brackets** to the radio chassis using (4) screws supplied with the radio. (Figure A)
2. Secure the radio display to the **Pioneer adapter brackets** using (4) screws supplied with the radio. (Figure B)

Note: Use the screw slots in the adapter brackets as shown. (Figure C)

3. Connect the radio display to the radio chassis.
4. Secure the **radio brackets** to the radio chassis using screws supplied with the radio. Note the location of the bracket on the radio and the screw slots to be used. (Figures D,E)

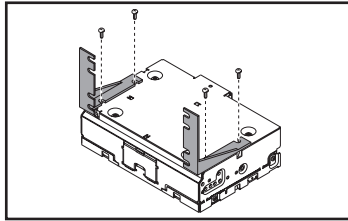

(Figure A)

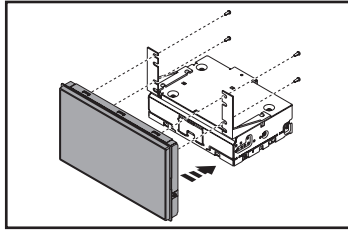

(Figure B)

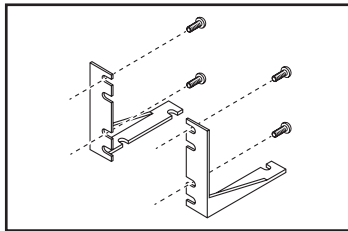

(Figure C)

5. Locate the factory wiring harness and antenna connector in the dash and complete all necessary connections to the radio. Metra recommends using the proper mating adapter from Metra and/or Axxess. Test the radio for proper operation.
6. Slide the radio assembly into the dash, then secure using the factory screws.
7. Secure the **trim panel clip brackets** to the **trim panel** using (4) Phillips screws provided. (Figure F)
9. Attach (2) **panel clips** provided onto the trim panel assembly.
10. Clip the trim panel assembly to the dash.
11. Reassemble the dash in reverse order of disassembly to complete the installation.

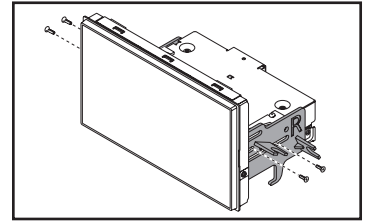

(Figure D)

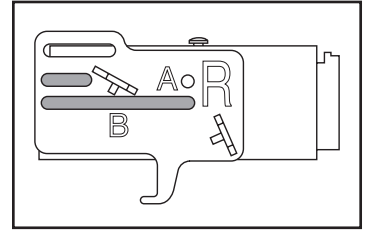

(Figure E)

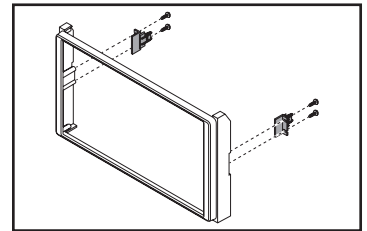

(Figure F)



108-T05HG

INSTALLATION INSTRUCTIONS



If you are having difficulties with the installation of this product, contact our Tech Support line either by phone at **386-257-1186 ext. 8300**, or email at **techsupport@metra-autosound.com**. Before doing so, look over the instruction booklet a second time and ensure that the installation was performed exactly as the instruction booklet is stated. Have the vehicle apart and ready to perform troubleshooting steps before contacting Metra/Axxess Tech Support.



® KNOWLEDGE IS POWER

Enhance your installation and fabrication skills by enrolling in the most recognized and respected mobile electronics school in our industry. Log onto www.installerinstitute.com or call 800-354-6782 for more information and take steps toward a better tomorrow.



Metra recommends MECP certified technicians