

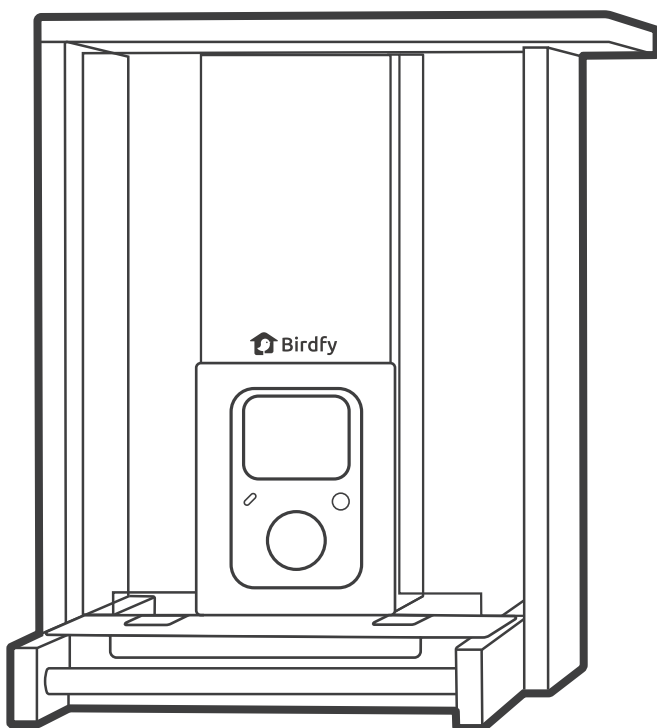

User Manual

Birdfy Feeder Bamboo



EN

ES

FR

Catalog

PRODUCT OVERVIEW

What's in the Box	1-6
Product Diagram	7-8

CAMERA GUIDE

Camera Diagram	9-10
Charge Before Use	11
Camera Status Light	12

INSTALLATION AND USE

Step 1: Download the Birdfy App	13
Step 2: Pair the Camera with the App	13-14
Step 3: Assemble the Product	15-20
Step 4: Outdoor Installation	21-27
Step 5: Add Birdseed	28

MAINTENANCE

Cleaning	29-31
Bamboo Maintenance	32

SUPPORT AND COMMUNITY

Support	33-34
The Birdfy Community	35

WARNING	36-38
----------------------	-------

Catálogo

DESCRIPCIÓN GENERAL DEL PRODUCTO

Qué hay en la caja 1-6
Diagrama del producto 7-8

GUÍA DE LA CÁMARA

Diagrama de la cámara 9-10
Cargar antes del primer uso 11
Luz de estado de la cámara 12

INSTALACIÓN Y USO

Paso 1: Descargar la app de Birdfy 13
Paso 2: Vincular la cámara con la aplicación 13-14
Paso 3: Ensamblar el producto 15-20
Paso 4: Instalación en exteriores 21-27
Paso 5: Añadir alpiste 28

MANTENIMIENTO

Limpieza 29-31
Mantenimiento del bambú 32

SOPORTE Y COMUNIDAD

Soporte 33-34
La Comunidad Birdfy 35

ADVERTENCIA 36-38

Catalogue

PRÉSENTATION DU PRODUIT

Contenu de la boîte	1-6
Schéma du produit	7-8

GUIDE DE LA CAMÉRA

Schéma de la caméra	9-10
Charger avant utilisation	11
Le voyant d'état de la caméra	12

INSTALLATION ET UTILISATION

Étape 1 : Télécharger l'application Birdfy	13
Étape 2 : Associer la caméra à l'application	13-14
Étape 3 : Assembler le produit	15-20
Étape 4 : Installation en extérieur	21-27
Étape 5 : Ajouter des graines pour oiseaux	28

ENTRETIEN

Nettoyage	29-31
Entretien du bambou	32

SUPPORT ET COMMUNAUTÉ

Assistance	33-34
La Communauté Birdfy	35

AVERTISSEMENT	36-38
----------------------------	-------

What's in the Box

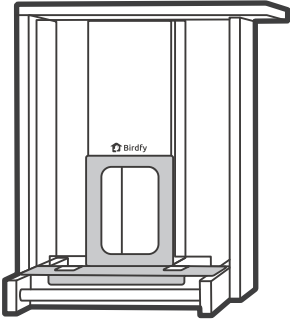

Feeder Metal seed guard
Comedero + Protector de semillas metálico
Mangeoire Protège-graines en métal

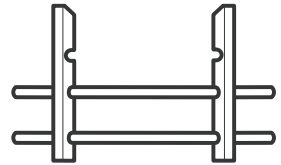
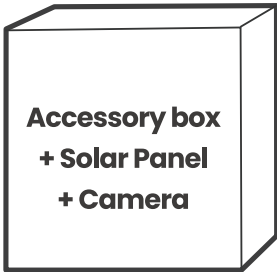

User Manual
Manual del usuario
Manuel de l'utilisateur

Extension perch
Percha extensible
Perchoir extensible

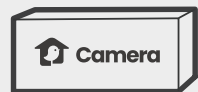
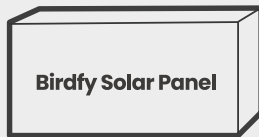
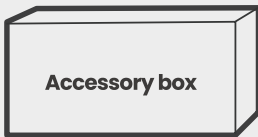

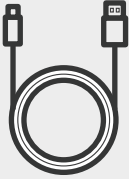

Charging cable
Cable de carga
Câble de charge

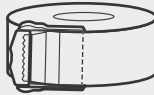

Black strap
Correa negra
Sangle noire

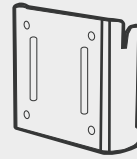

Hanging bracket
Soporte de suspensión
Support de suspension



Screwdriver
Destornillador
Tournevis



Antenna
Antena
Antenne

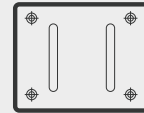

Drilling template
Plantilla de perforación
Gabarit de perçage

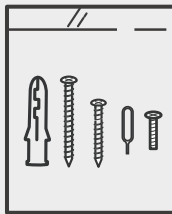

A

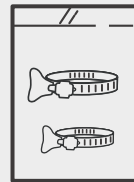

B

PRODUCT OVERVIEW

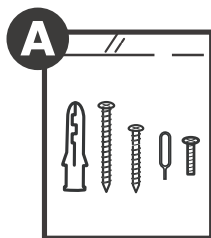

Ejector pin
Pasador expulsor
Goupille d'éjection



Anchors
Anclajes
Chevilles



Perch screws
Tornillos para perchas
Vis pour perchoir



Screws for mounting
on wood
Tornillos para montaje
en madera
Vis pour fixation sur bois



Screws for mounting
on concrete
Tornillos para montaje
en concreto
Vis pour fixation sur béton

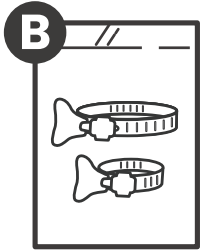

x2

Hose clips (large)
Clips para
manguera (grandes)
Colliers de
serrage (grands)



x2

Hose clips (small)
Clips para
manguera (pequeños)
Colliers de
serrage (petits)



Camera
Cámara
Caméra

PRODUCT OVERVIEW

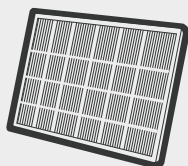
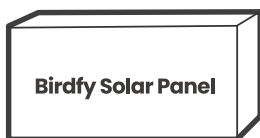

Solar panel
Panel solar
Panneau solaire

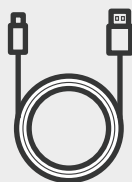

Charging cable
Cable de carga
Câble de charge



User Manual
Manual del usuario
Manuel de l'utilisateur



Spacer rings
Anillos separadoras
Baques d'espacement



Hose clips
Clips para manguera
Colliers de serrage



Nut
Tuerca
Écrou



Mounting arm
Brazo de montaje
Bras de montage



Drilling Template
Plantilla de perforación
Gabarit de perçage



Mounting bracket
Soporte de montaje
Support de montage

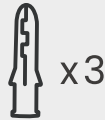
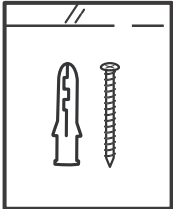
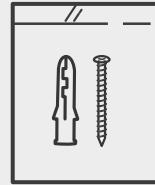

Anchors
Anclajes
Chevilles

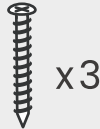

Screws
Tornillos
Vis

Product Diagram

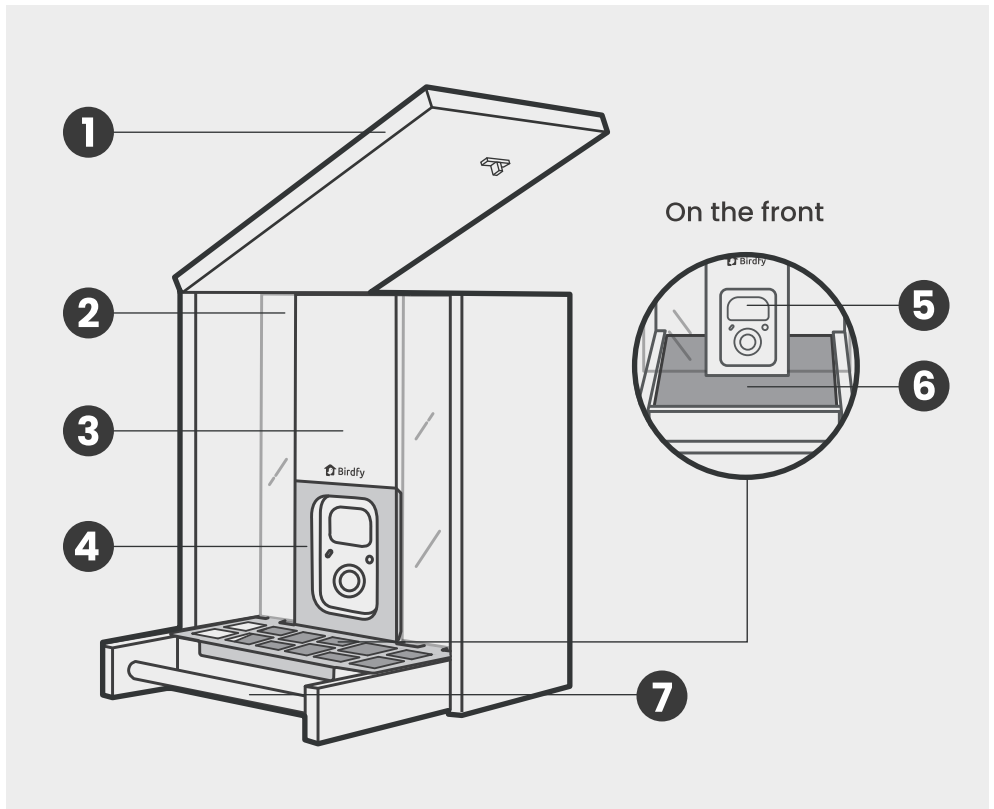

1 Seed bin cover
Tapa del contenedor de semillas
Couvercle du com-partiment à graines

2 Acrylic panel
Panel acrílico
Panneau en acrylique

3 Camera compartment cover
Cubierta del compartimento de la cámara
Couvercle du compartiment caméra

4 Metal seed guard
Protector metálico de semillas
Grille métallique pour graines

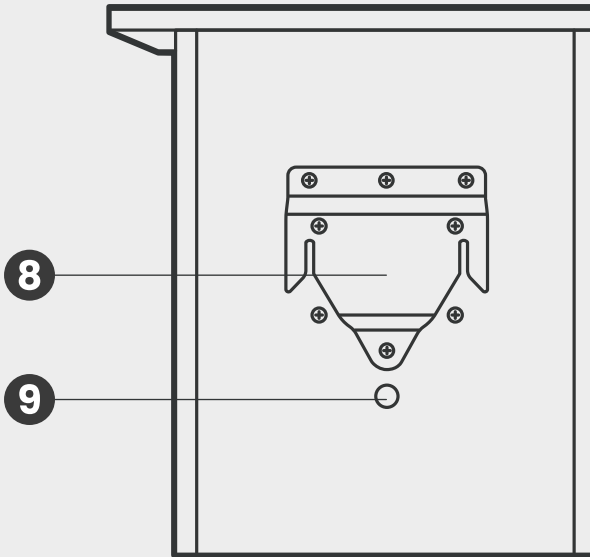

At the back

5 Camera
Cámara
Caméra

6 Metal mesh
Malla metálica
Grille métallique

7 Perch
Posadero
Perchoir

8 Mounting bracket
Soporte de montaje
Support de montage

9 Charging cable port
Puerto de carga del cable
Port de câble de charge

Camera Diagram

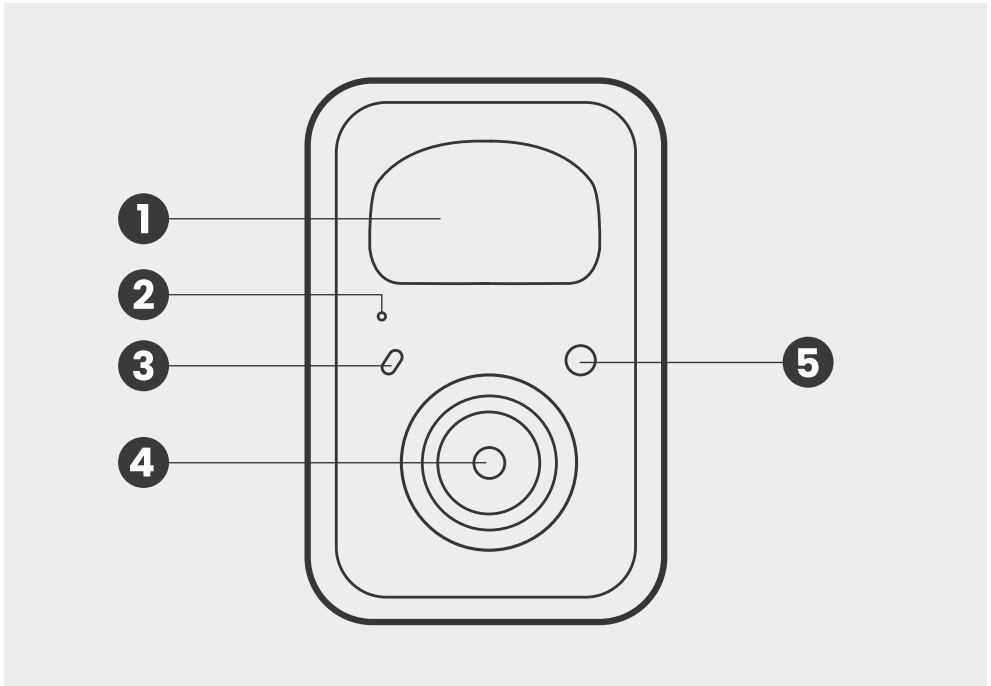

1 Motion sensor
Sensor de movimiento
Capteur de mouvement

2 Microphone
Micrófono
Microphone

3 Status light
Luz de estado
Le voyant d'état

4 White light
(for night vision)
Luz blanca
(para visión nocturna)
Lumière blanche
(pour vision nocturne)

5 Lens
Lente
Objectif

At the top

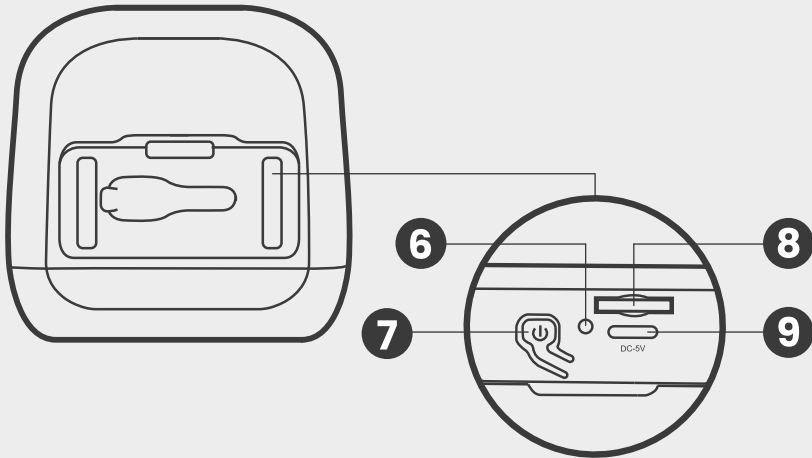

*Please note that the microSD card slot on the camera is intended only for manufacturer testing during production. This product does not support microSD card storage.

*Por favor, ten en cuenta que la ranura para tarjeta microSD en la cámara está destinada únicamente para pruebas de fabricante durante la producción. Este producto no admite almacenamiento en tarjetas microSD.

*Veuillez noter que le slot de carte microSD sur l'appareil photo est réservé uniquement aux tests du fabricant pendant la production. Ce produit ne prend pas en charge le stockage sur carte microSD.

- 6** Reboot hole
Orificio de reinicio
Trou de réinitialisation
- 8** microSD card slot
Ranura para tarjeta microSD
Fente pour carte microSD

- 7** Power button
Botón de encendido
Bouton d'alimentation
- 9** Charging port
Puerto de carga
Port de charge

Charge Before Use

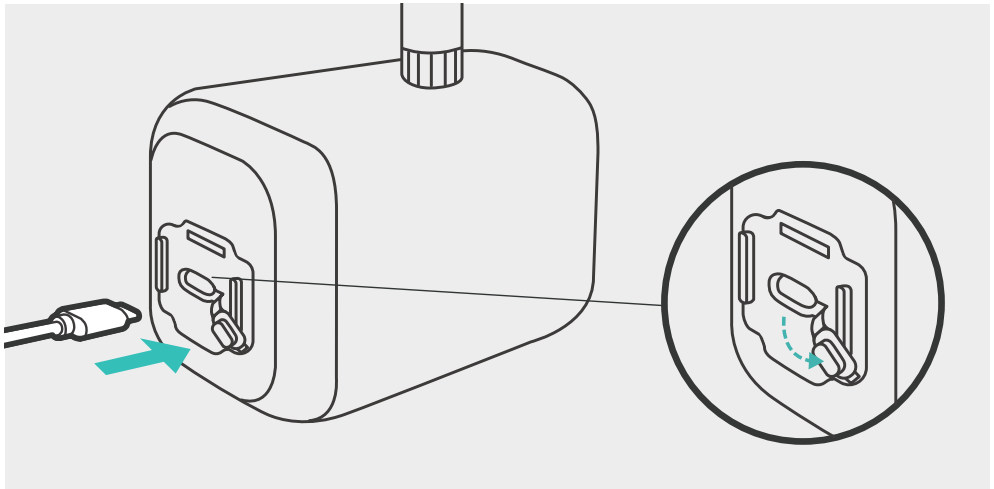

Fully charge the camera before use

For safety reasons, the camera is not fully charged when packaged. Please use the included charging cable (DC 5V / 1.5A) found in the accessory box to fully charge the camera before first use.







Cargue completamente la cámara antes de usarla

Por razones de seguridad, la cámara no está completamente cargada cuando se empaqueta. Por favor, utilice el cable de carga incluido (DC 5V / 1.5A) que se encuentra en la caja de accesorios para cargar completamente la cámara antes del primer uso.

Chargez complètement la caméra avant utilisation

Pour des raisons de sécurité, la caméra n'est pas complètement chargée lorsqu'elle est emballée. Veuillez utiliser le câble de charge inclus (DC 5V / 1.5A) situé dans la boîte d'accessoires pour charger complètement la caméra avant la première utilisation.

Camera Status Light

Status Light Luz de estado Le voyant d'état	Description Descripción Description
 Solid green Verde sólido Vert fixe	Fully charged Completamente cargado Complètement chargé
 Solid yellow Amarillo sólido Jaune fixe	Charging Cargando En charge
 Flashing yellow Amarillo intermitente Jaune clignotant	Low battery Batería baja Batterie faible
 Solid blue Azul sólido Bleu fixe	Working Funcionando En fonctionnement
 Flashing blue Destello azul Clignotant bleu	Wi-Fi config mode Modo de configuración de Wi-Fi Mode de configuration Wi-Fi
 None Apagada Éteint	Sleep / Power off Reposo / Apagado Repos / Éteint



When charging and operating, both the ambient temperature and camera temperature should be within 14°F to 113°F (-10°C to 45°C). If the camera has been exposed to low temperatures for an extended period, it should be brought back to room temperature before charging.

Durante la carga y el funcionamiento, tanto la temperatura ambiente como la de la cámara deben estar entre 14°F y 113°F (-10°C a 45°C). Si la cámara ha estado expuesta a bajas temperaturas durante un período prolongado, debe llevarse a temperatura ambiente antes de cargarla.

Lors de la charge et de l'utilisation, la température ambiante et celle de la caméra doivent se situer entre 14°F et 113°F (-10°C à 45°C). Si la caméra a été exposée à des températures basses pendant une période prolongée, elle doit être ramenée à température ambiante avant la recharge.

Step 1: Download the Birdfy App



A large teal QR code is positioned on the left, featuring a small Birdfy logo in the center. To its right are two dark grey buttons. The top button contains the Apple logo and the text "Download on the App Store". The bottom button contains the Google Play logo and the text "GET IT ON Google Play".

Step 2: Pair the Camera with the App

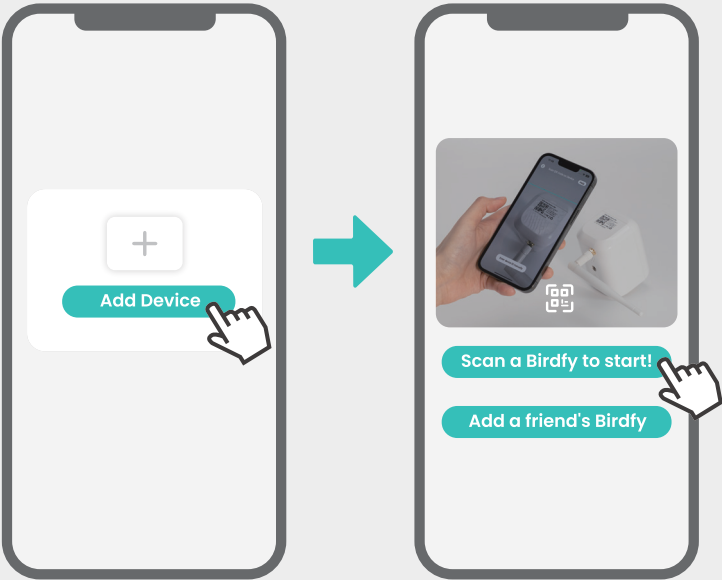

The diagram illustrates the app's pairing process in two stages. On the left, a smartphone screen shows a white box with a plus sign and a teal "Add Device" button, with a hand icon pointing to it. A teal arrow points to the right, where the app's main menu is shown. The menu includes a QR code scanner icon, a teal "Scan a Birdfy to start!" button, and a teal "Add a friend's Birdfy" button, with a hand icon pointing to the first button.

Bird Identification

- If you have the Birdfy Feeder Bamboo with Lifetime Free AI, the AI bird identification feature is included and activated automatically, no further action needed.
- If you have the Birdfy Feeder Bamboo with AI by Subscription, you need to subscribe on **my.birdfy.com** to access this feature.

Bird Identification

- Si tienes el Birdfy Feeder Bamboo con AI de por vida gratuita, la función de identificación de aves con IA está incluida y se activa automáticamente, no necesitas hacer nada más.
- Si tienes el Birdfy Feeder Bamboo con AI por suscripción, debes suscribirte en **my.birdfy.com** para acceder a esta función.

Identification des oiseaux

- Si vous possédez le Birdfy Feeder Bamboo avec l'IA à vie gratuite, la fonctionnalité d'identification des oiseaux par IA est incluse et activée automatiquement, aucune action supplémentaire n'est nécessaire.
- Si vous possédez le Birdfy Feeder Bamboo avec l'IA par abonnement, vous devez vous abonner sur **my.birdfy.com** pour accéder à cette fonctionnalité.

Step 3: Assemble the Product

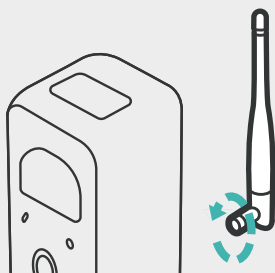

- * Attach the antenna to the back of the camera.
- * Coloque la antena en la parte posterior de la cámara.
- * Fixez l'antenne à l'arrière de la caméra.

- 1** Open the seed bin cover.
Abra la tapa del depósito de semillas.
Ouvrez le couvercle du réservoir à graines.

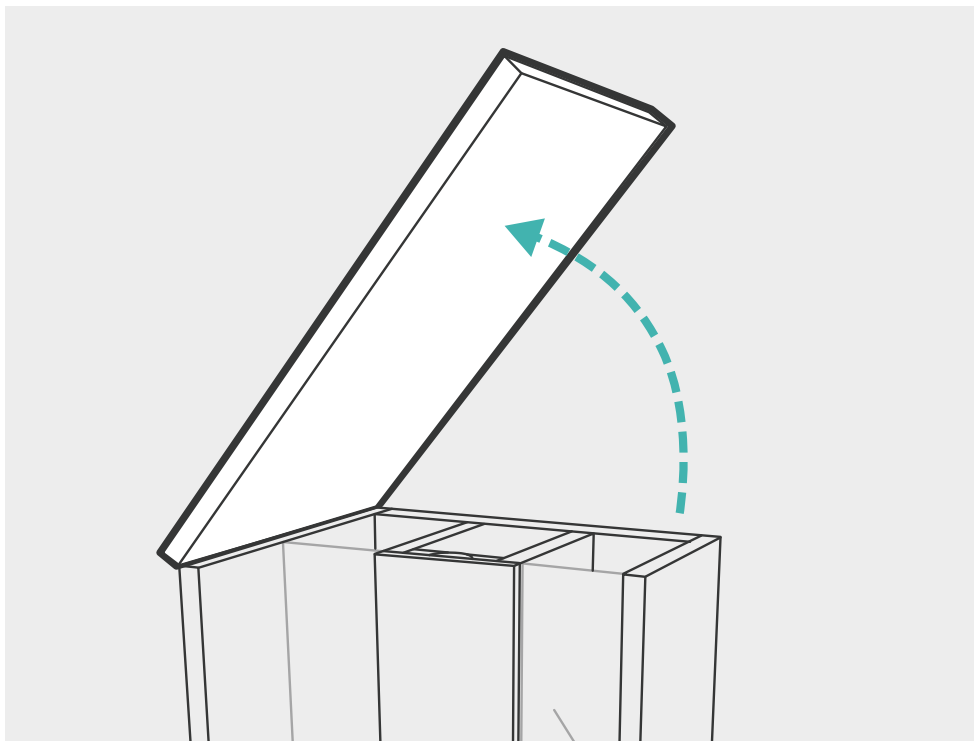

- 2** Remove the metal seed guard.
 LRetire la rejilla metálica de protección de semillas.
 Retirez la grille métallique de protection des graines.

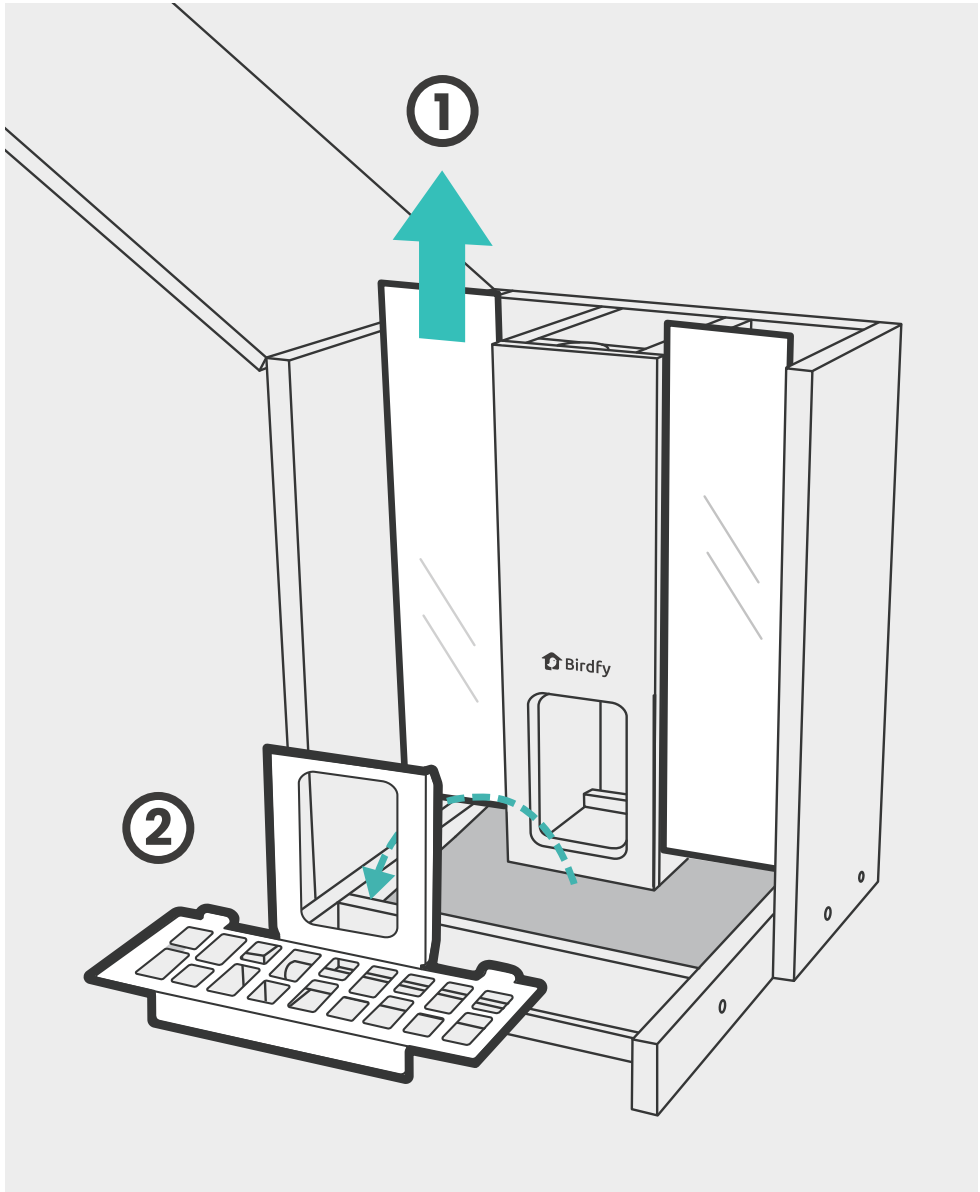

INSTALLATION AND USE

- 3** Open the camera compartment cover.
Abra la tapa del compartimento de la cámara.
Ouvrez le couvercle du compartiment de la caméra.

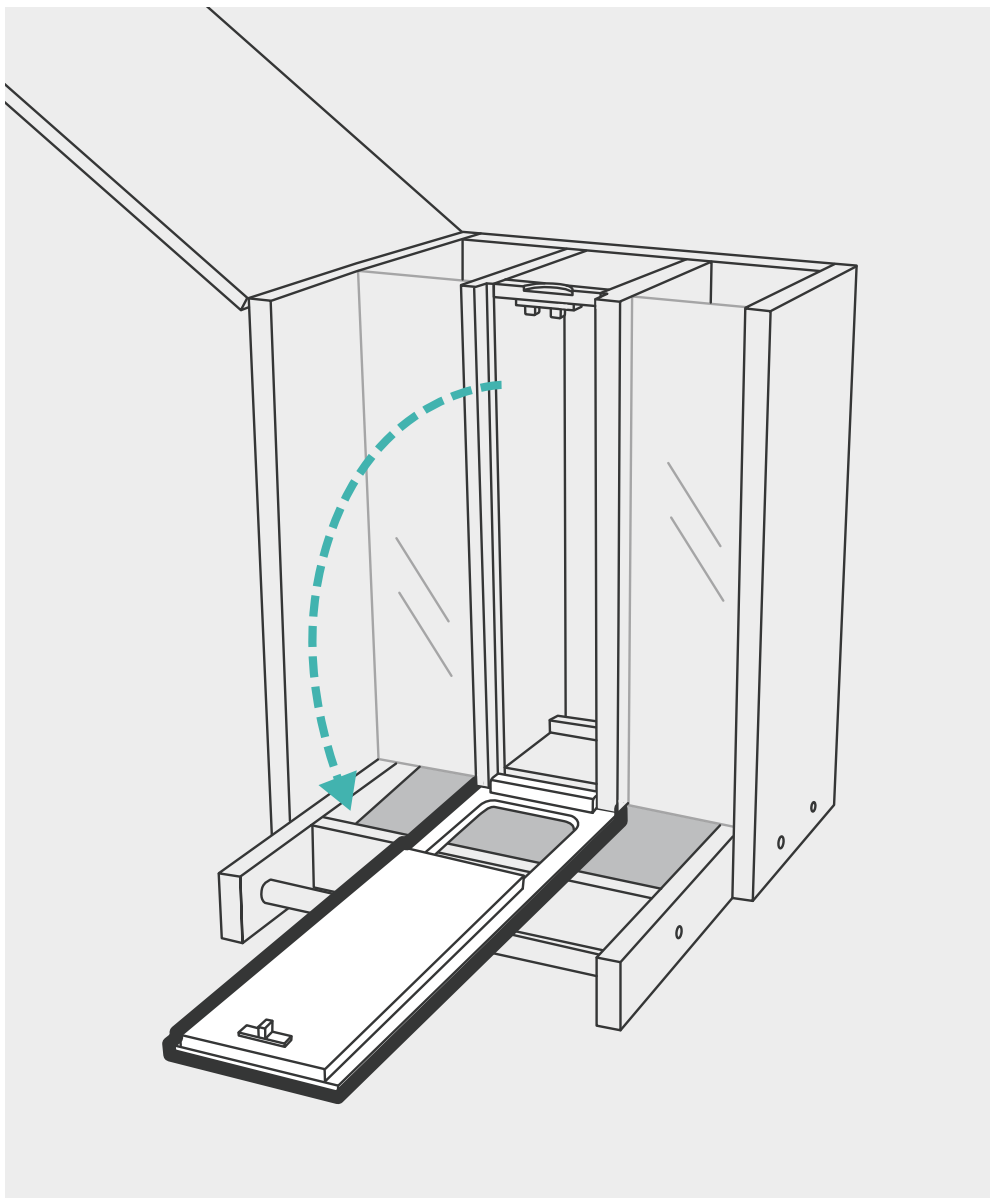

4 Feed the charging cable through the hole on the back of the feeder and connect it to the paired camera.

Pase el cable de carga por el orificio en la parte trasera del comedero y conéctelo a la cámara emparejada.

Faites passer le câble de charge par le trou à l'arrière de la mangeoire et connectez-le à la caméra jumelée.

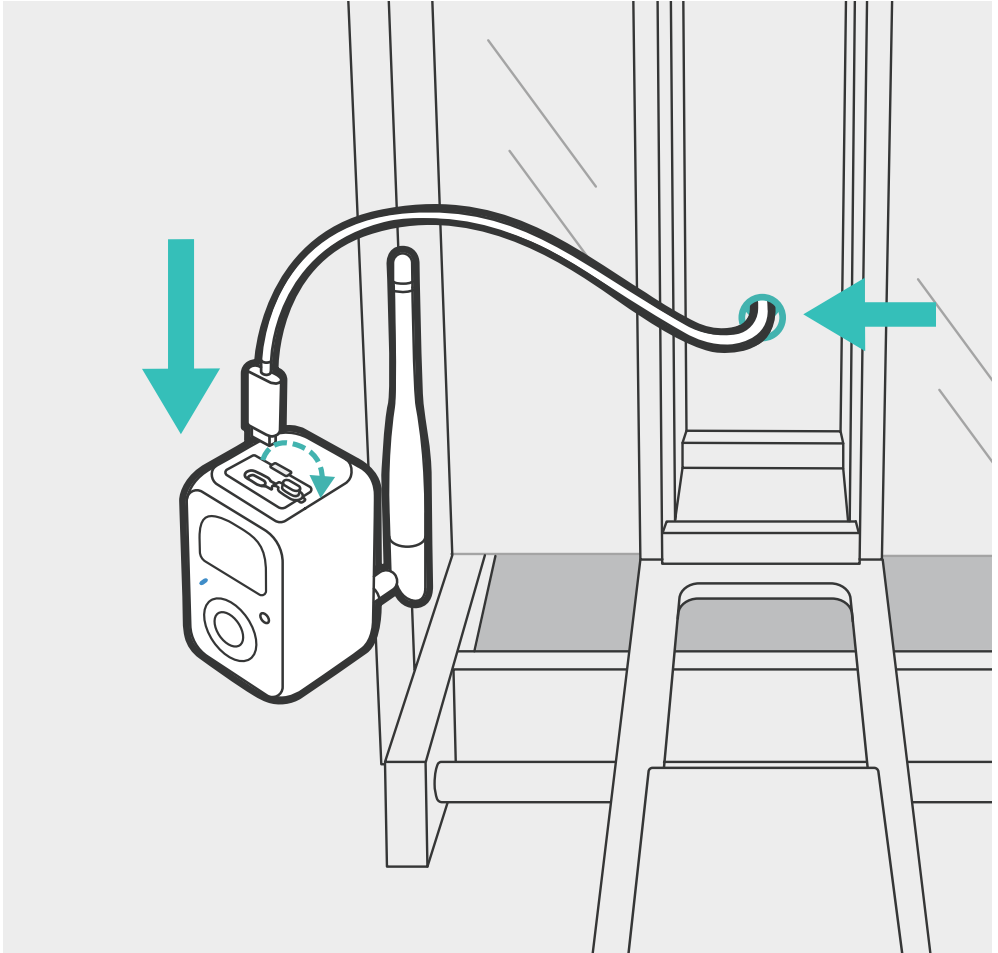

*Check the solar panel instruction manual for installation details.

*Consulte el manual de instrucciones del panel solar (para más detalles sobre la instalación).

*Veuillez consulter le manuel d'instructions du panneau solaire pour plus de détails sur l'installation.

INSTALLATION AND USE

- 5** Place the paired camera into the camera compartment.
Coloque la cámara emparejada en el compartimento.
Placez la caméra jumelée dans le compartiment.

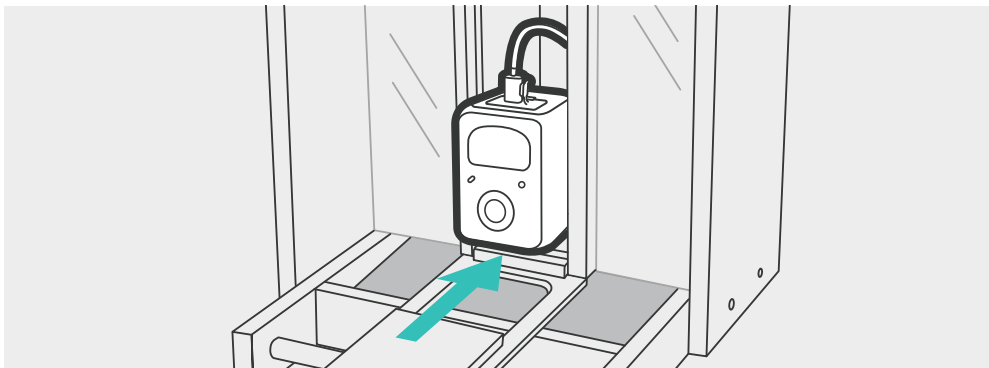

- 6** Close the camera compartment cover.
Cierre la tapa del compartimento de la cámara.
Fermez le couvercle du compartiment de la caméra.

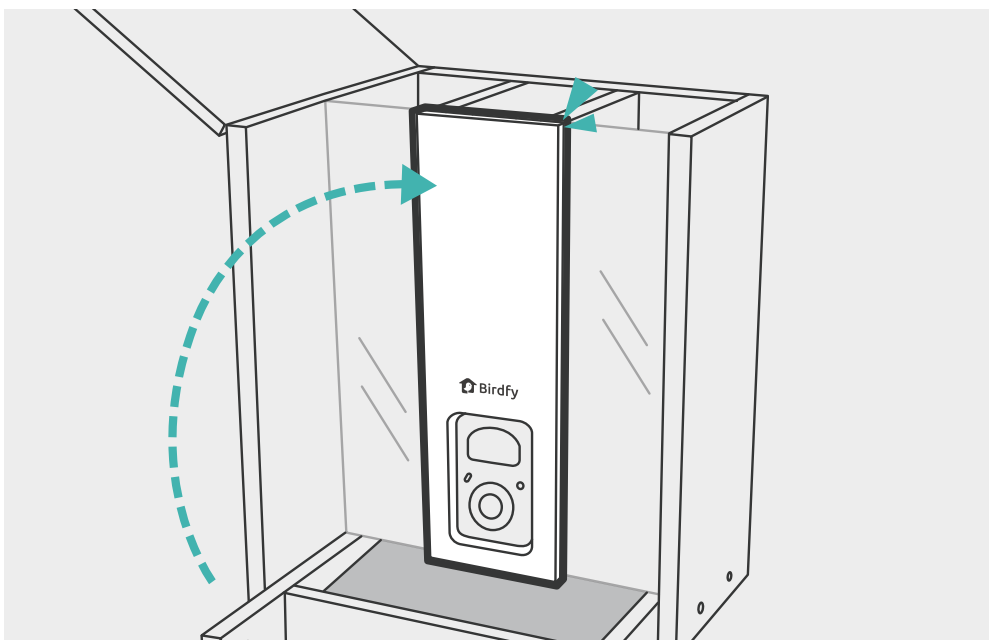

- 7** Replace the metal seed guard.
 Vuelva a colocar la rejilla metálica de protección de semillas.
 Remettez la grille métallique de protection des graines.

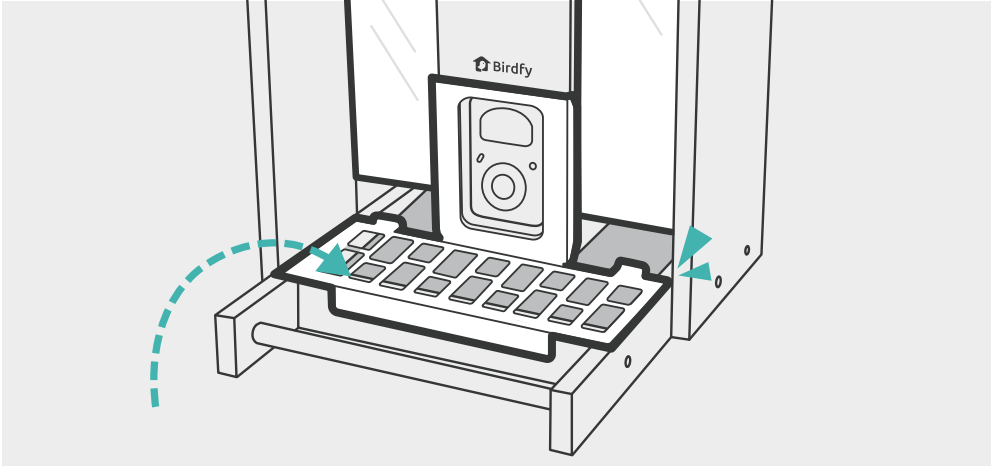

- 8** Install the extension perch with the provided screws.
 Instale el posadero de extensión con los tornillos incluidos.
 Installez le perchoir d'extension à l'aide des vis fournies.

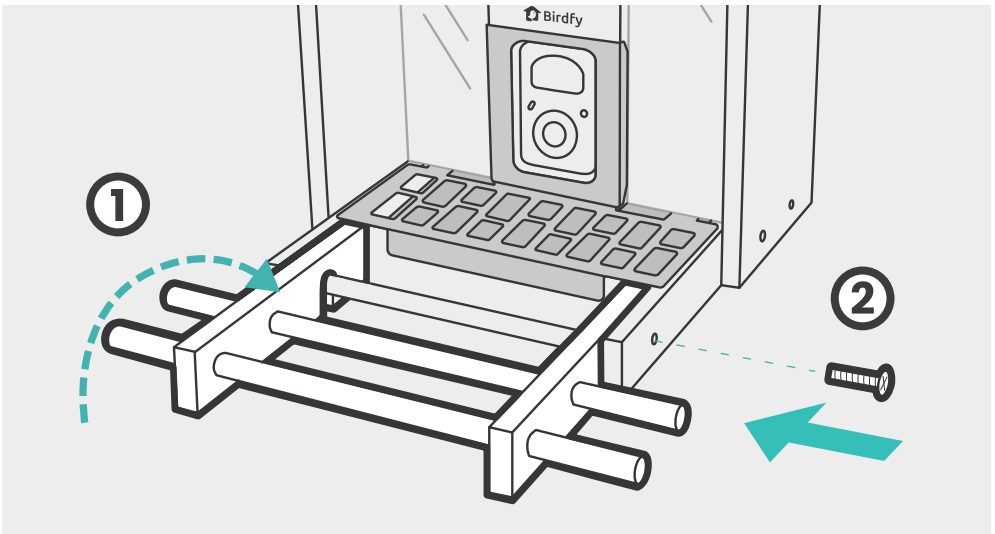

Step 4: Outdoor Installation

A. Pole-mounted



Hose clips (large/small)

Clips para manguera (grandes/pequeños)

Pinces pour tuyau (grands/petits)



Hanging bracket

Soporte de suspensión

Support de suspension

1

Loosen the hose clip.

Afloje la abrazadera de la manguera.

Desserrer le collier de serrage.

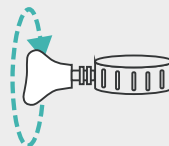

2

Wrap the hose clip around the hanging bracket.

Envuelva la abrazadera de la manguera alrededor del soporte.

Enrouler le collier de serrage autour du support.

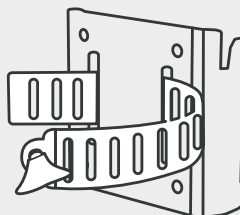

- 3** Attach the hanging bracket to the pole.
 Coloque el soporte en el poste.
 Fixer le support sur le poteau.

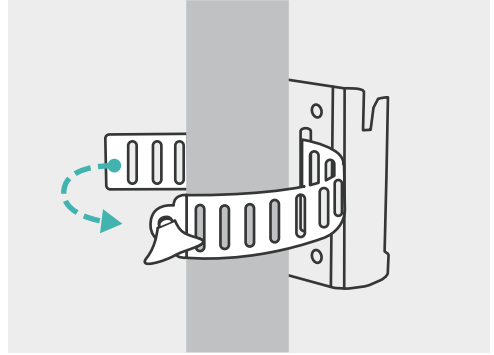

- 4** Hang the feeder on the pole.
 Cuelgue el comedero en el poste.
 Accrocher le distributeur sur le poteau.

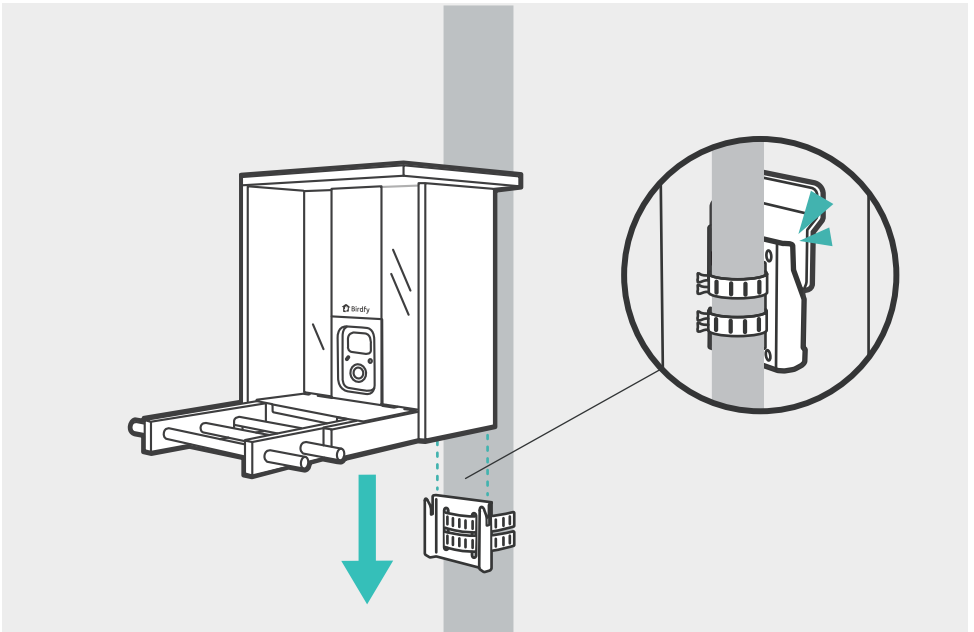

B. Tree-mounted



Black strap
Correa negra
Sangle noire



Hanging bracket
Soporte de suspensión
Support de suspension

- 1** Slide the strap through the bracket slots.

Deslice la correa a través de las ranuras del soporte.
Faites glisser la sangle à travers les fentes du support.

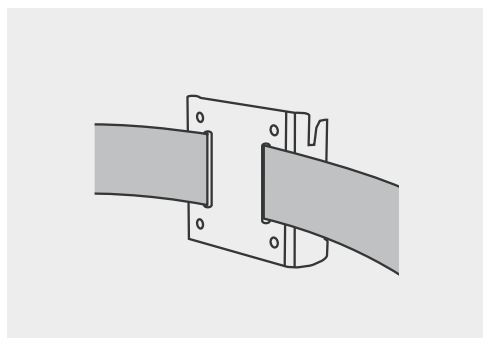

- 2** Wrap the strap around the tree.

Envuelva la correa alrededor del árbol.
Enroulez la sangle autour de l'arbre.

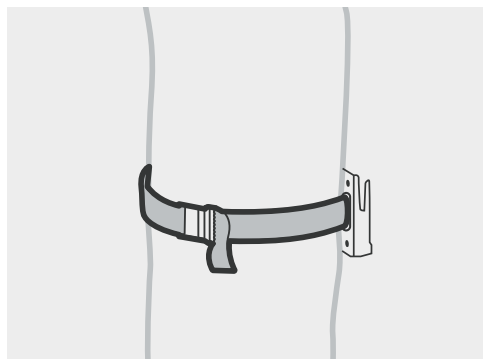

- 3** Hang the feeder onto the tree.
 Cuelgue el comedero en el árbol.
 Accrochez le distributeur sur l'arbre.

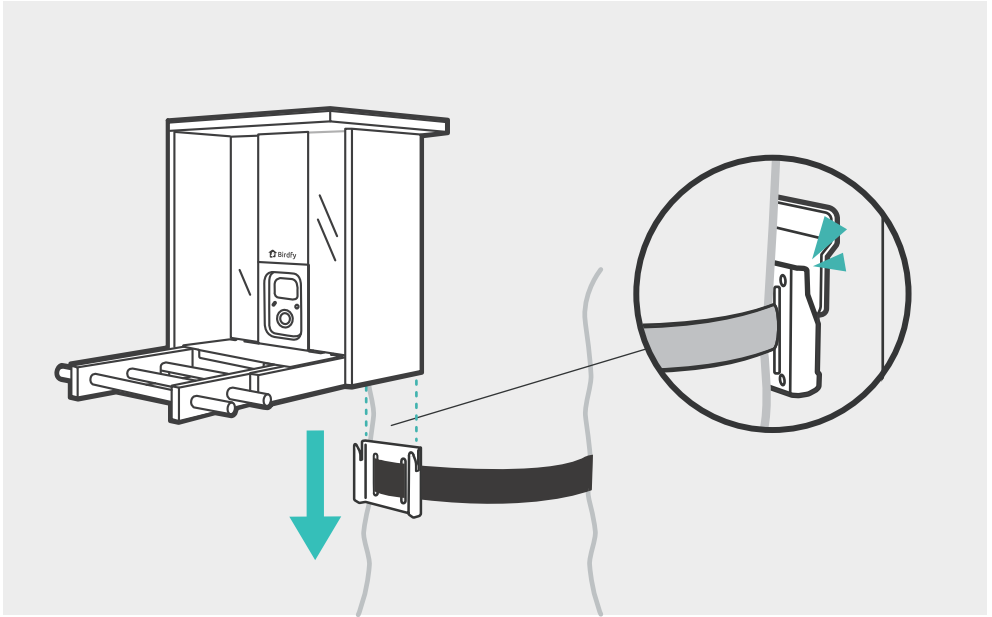

C. Wall-mounted



Drilling template
Plantilla de perforación
Gabarit de perçage



Anchors
Anclajes
Chevilles



Hanging bracket
Soporte de suspensión
Support de suspension



Screws for mounting on wood
Tornillos para montaje en madera
Vis pour fixation sur bois



Screws for mounting on concrete
Tornillos para montaje en concreto
Vis pour montage sur béton

1

Use the drill template and an electric drill (15/64", 6mm) to drill four holes.

Utiliza la plantilla de perforación y un taladro eléctrico (15/64", 6mm) para perforar cuatro agujeros.
Utilisez le gabarit de perçage et une perceuse électrique (15/64", 6 mm) pour percer quatre trous.

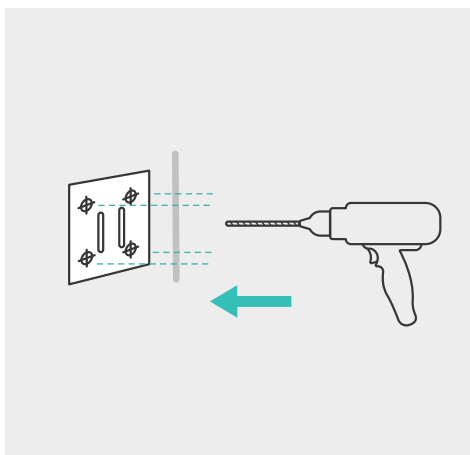

- 2** Drive the provided plastic anchors into the holes. Skip this step if you are mounting on wood.

Inserta los anclajes de plástico provistos en los agujeros.

Omite este paso si vas a montar en madera.

Insérez les chevilles en plastique fournies dans les trous.

Passez cette étape si vous montez sur du bois.

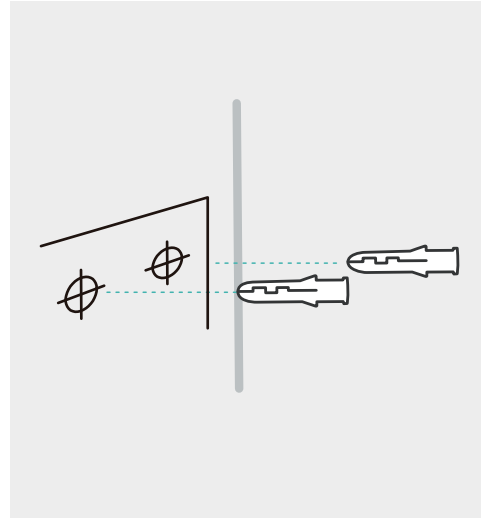

- 3** Next, fasten the hanging bracket on the wall using the screws.
- A continuación, fija el soporte de suspensión en la pared utilizando los tornillos.

Ensuite, fixez le support de suspension sur le mur à l'aide des vis.

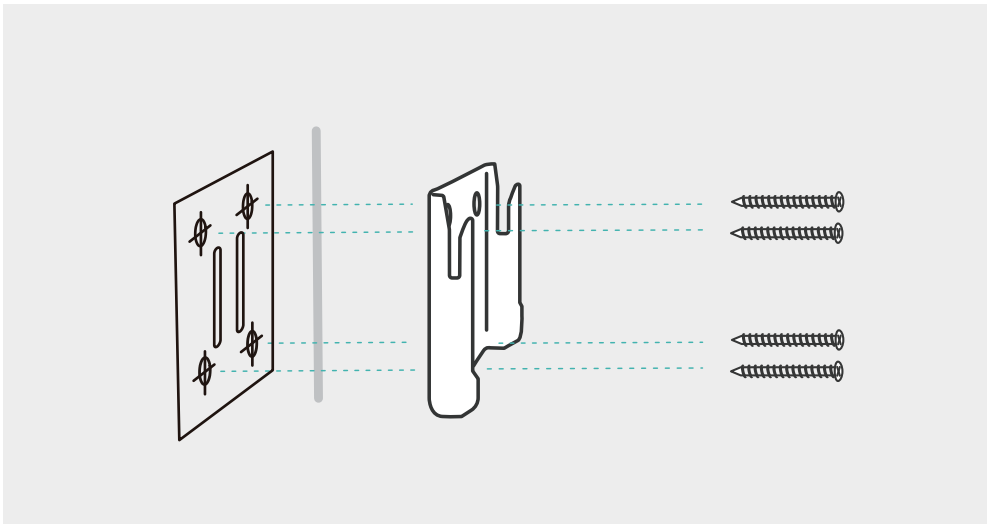

INSTALLATION AND USE

- 4** Hang the feeder onto the wall.
Cuelga el comedero en la pared.
Accrochez la mangeoire au mur.

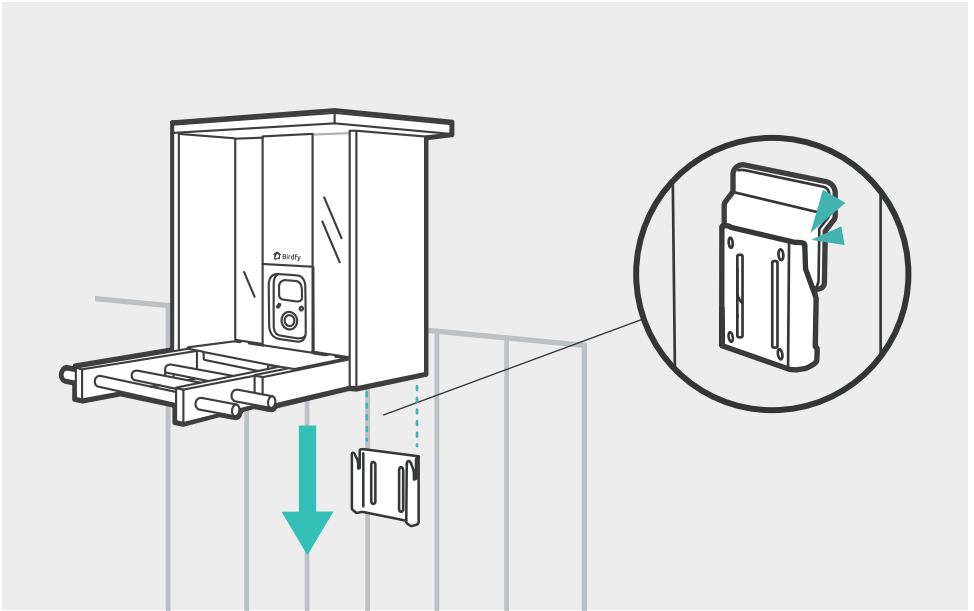

Step 5: Add Birdseed

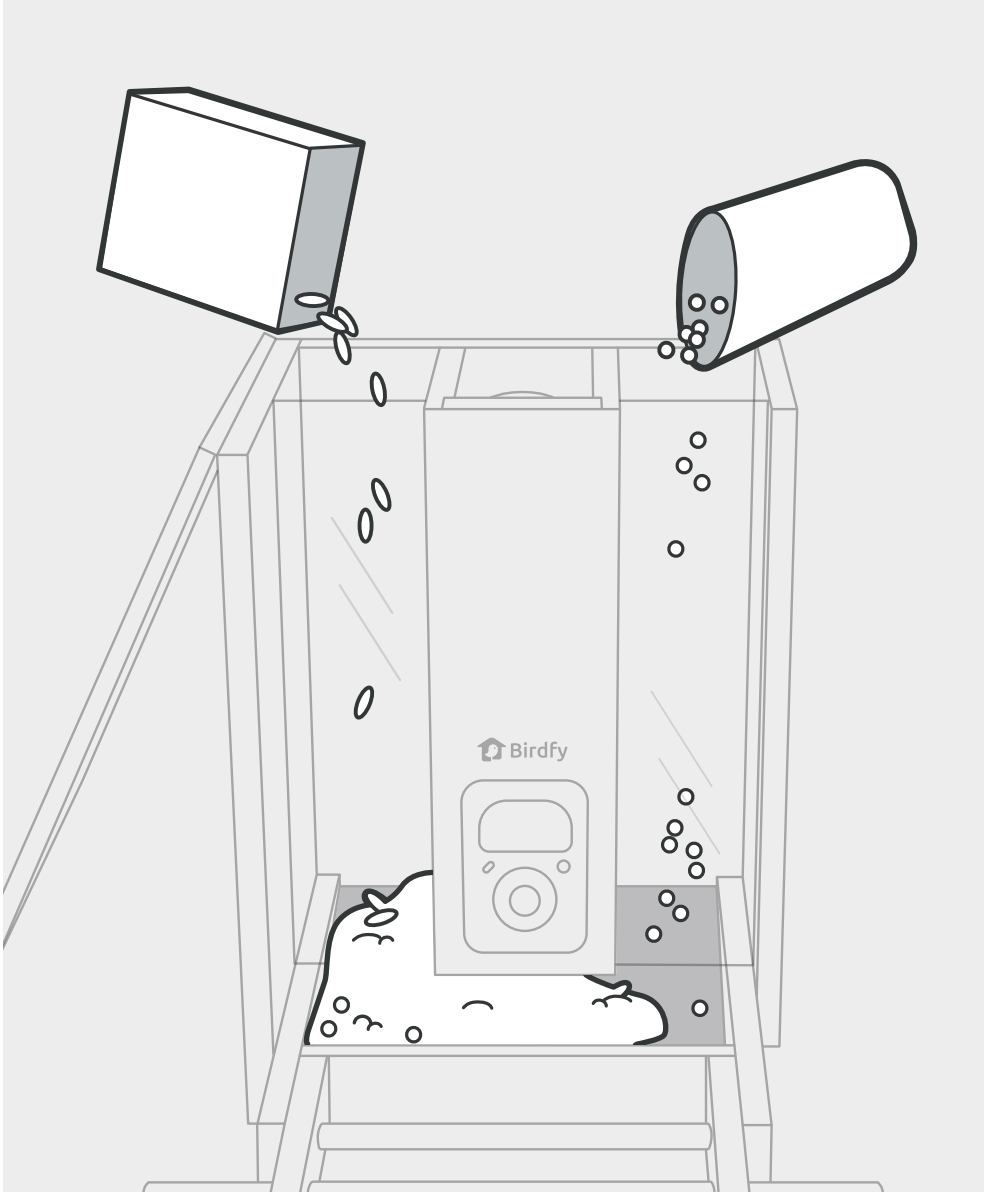

Cleaning

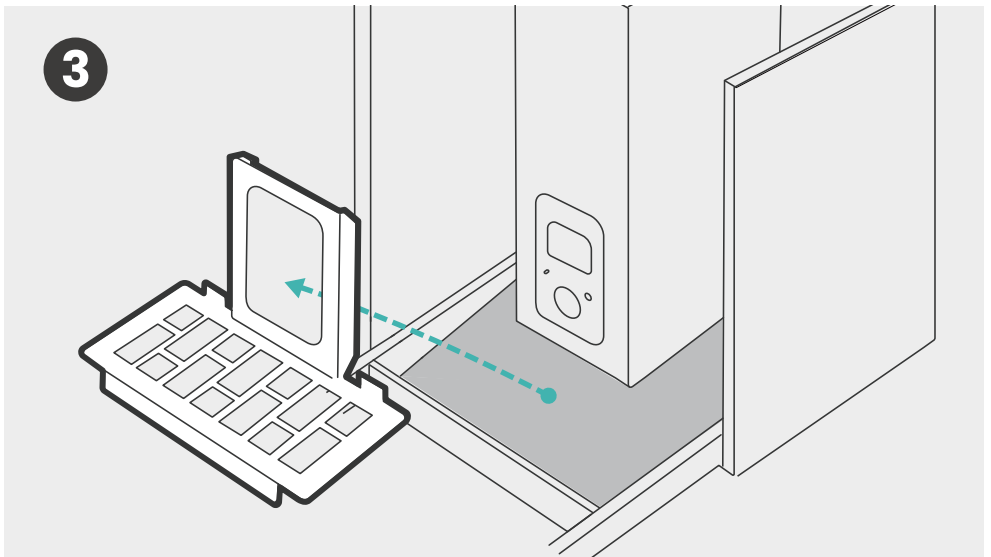
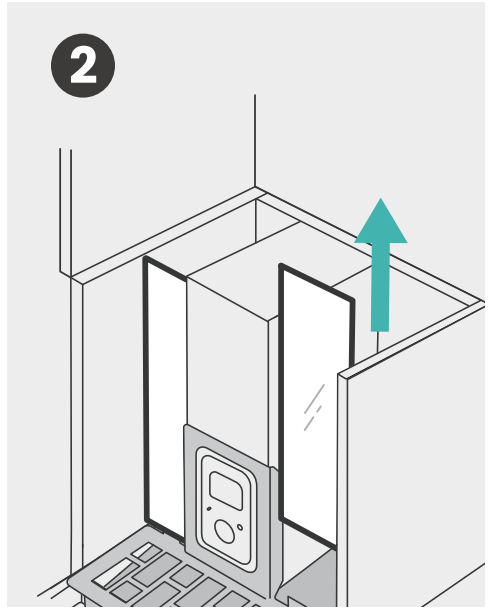
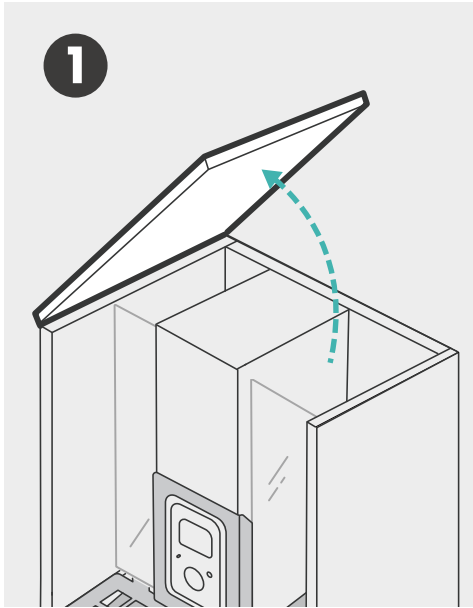

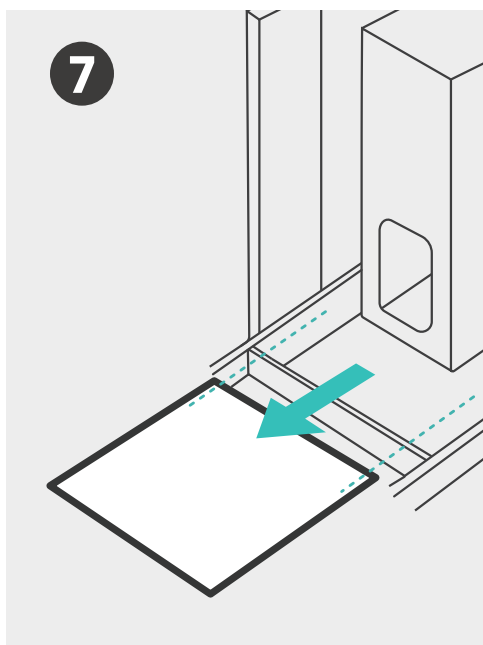
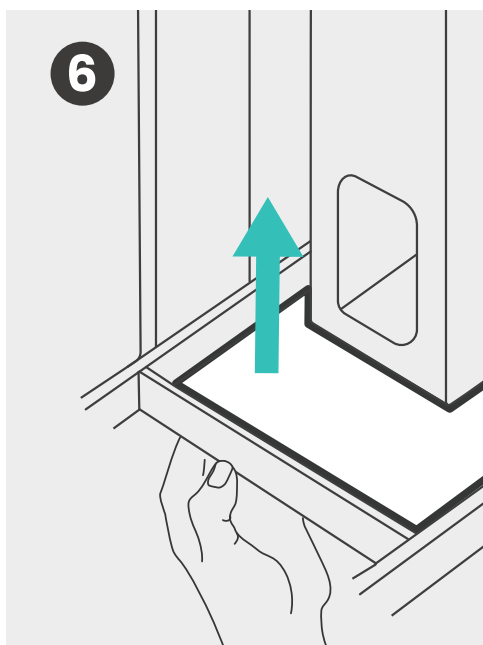
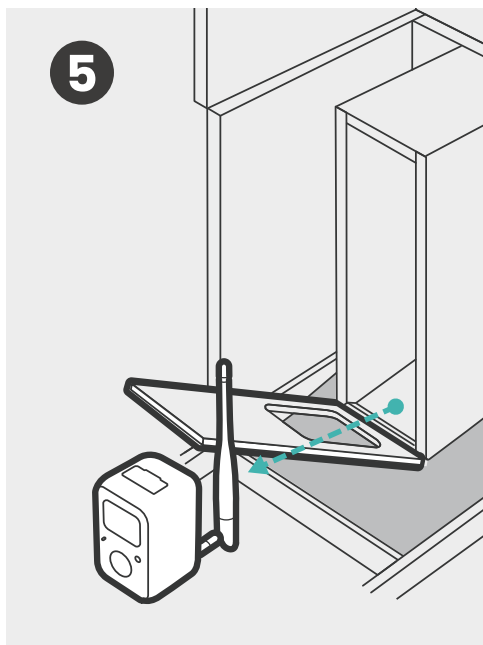
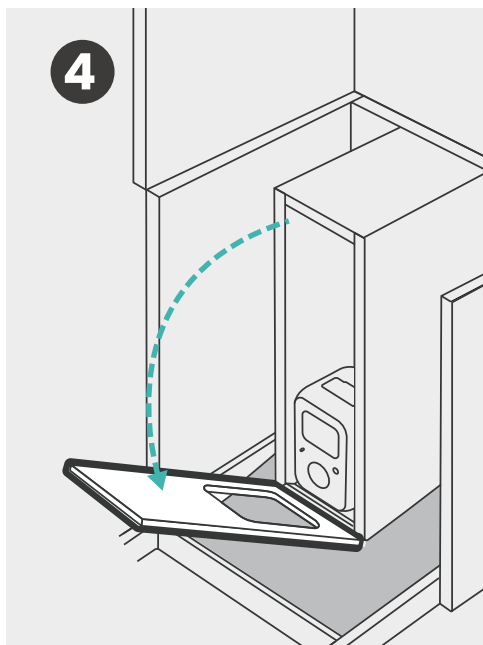

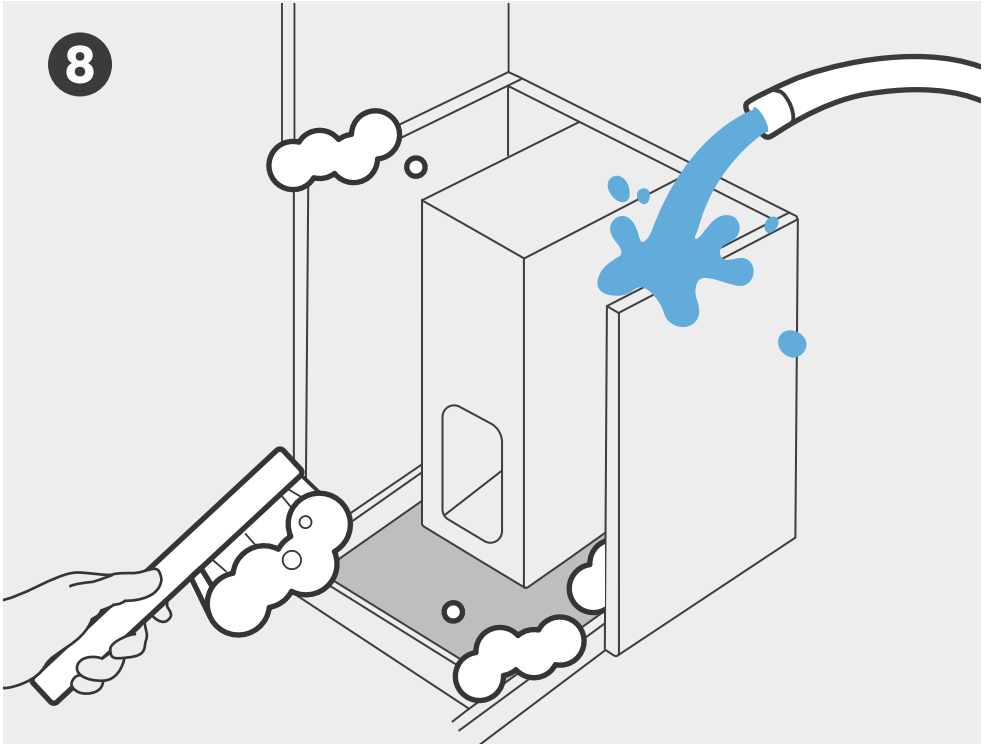

*Please note that bleach should not be used.

*Ten en cuenta que no se debe usar lejía.

*Veuillez noter qu'il ne faut pas utiliser d'eau de Javel.

Bamboo Maintenance

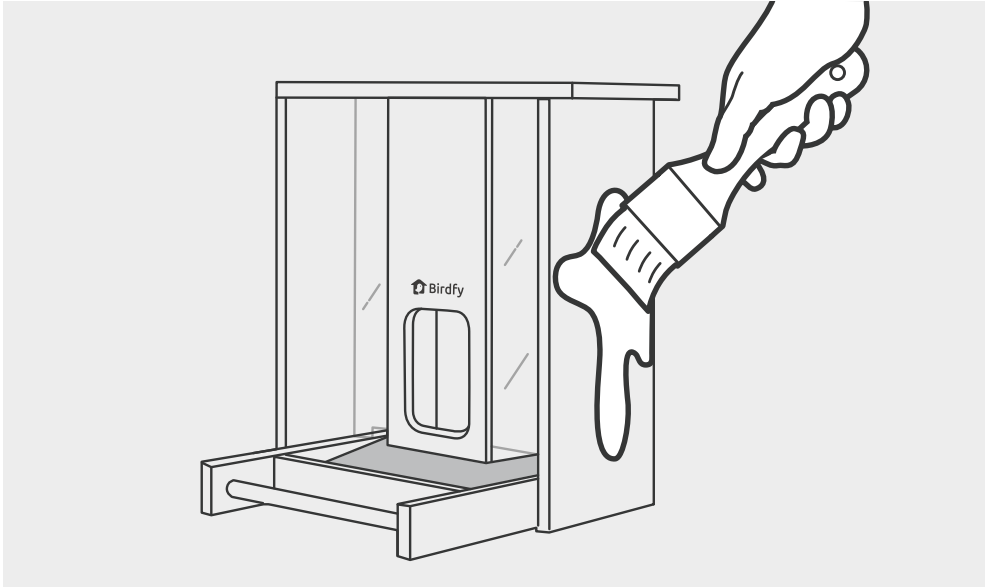

The Birdfy bamboo housing is double carbonized and sealed for weather resistance, but slight aging or mildew may occur. Clean and re-seal as needed, or every 3–6 months to maintain it.

La carcasa de bambú de Birdfy está doblemente carbonizada y sellada para resistir las inclemencias del tiempo, pero pueden aparecer ligeros signos de envejecimiento o moho. Límpiela y vuelve a sellarla según sea necesario, o cada 3–6 meses para mantenerla en buen estado.

Le boîtier en bambou Birdfy est doublement carbonisé et scellé pour résister aux intempéries, mais un léger vieillissement ou de la moisissure peuvent apparaître. Nettoyez et appliquez à nouveau un scellant au besoin, ou tous les 3 à 6 mois pour le maintenir en bon état.

Support

If your Birdfy camera **goes offline or fails to stream**, try these troubleshooting steps:

- 1. Ensure the camera is fully charged.**
- 2. Verify your home Wi-Fi connectivity. Try to reconnect the camera to your Wi-Fi network.**

If the issue persists:

- 1. Disconnect the camera from the solar panel or charger.**
- 2. Use the provided ejector pin or a paperclip to press the reboot hole to power down the camera entirely.**
- 3. Press and hold the power button for 3 seconds to restart the camera.**

Need help? Contact us for any questions or issues:

 support@birdfy.com (Global)

 In-App Chat (Global)

 1(866)749-0567 (US Only)

Si tu cámara Birdfy **se desconecta o no transmite video**, prueba estos pasos para solucionar el problema:

- 1. Asegúrate de que la cámara esté completamente cargada.**
- 2. Verifica la conexión Wi-Fi de tu hogar. Intenta reconectar la cámara a tu red Wi-Fi.**

Si el problema persiste:

- 1. Desconecta la cámara del panel solar o del cargador.**
- 2. Usa el pasador de expulsión proporcionado o un clip de papel para presionar el orificio de reinicio y apagar completamente la cámara.**
- 3. Mantén presionado el botón de encendido durante 3 segundos para reiniciar la cámara.**

¿Necesitas ayuda? Contáctanos si tienes preguntas o algún problema:

✉ support@birdfy.com (Global)

💬 Chat en la aplicación (Global)

☎ 1(866)749-0567 (solo EE. UU.)

Si votre caméra Birdfy **se déconnecte ou n'arrive pas à diffuser**, essayez ces étapes de dépannage :

- 1. Assurez-vous que la caméra est complètement chargée.**
- 2. Vérifiez la connexion Wi-Fi de votre domicile. Essayez de reconnecter la caméra à votre réseau Wi-Fi.**

Si le problème persiste :

- 1. Débranchez la caméra du panneau solaire ou du chargeur.**
- 2. Utilisez le poinçon d'éjection fourni ou un trombone pour appuyer sur le trou de réinitialisation et éteindre complètement la caméra.**
- 3. Maintenez le bouton d'alimentation enfoncé pendant 3 secondes pour redémarrer la caméra.**

Besoin d'aide ? Contactez-nous pour toute question ou problème :

✉ support@birdfy.com (Global)

💬 Chat intégré à l'application (Global)

☎ 1(866)749-0567 (États-Unis uniquement)



Birdfy Help Center

The Birdfy Community

Scan the QR code to join our vibrant Facebook community and connect with fellow bird enthusiasts! Discover valuable insights on birdwatching and bird feeding techniques, exchange your finest Birdfy captures, and witness exotic birds from around the world!

Escanee el código QR para unirse a nuestra vibrante comunidad de Facebook y conectarse con otros entusiastas de las aves. Descubra información valiosa sobre observación de aves y técnicas de alimentación, intercambie sus mejores capturas de Birdfy y observe aves exóticas de todo el mundo.

Scannez le code QR pour rejoindre notre communauté Facebook dynamique et vous connecter avec d'autres passionnés d'oiseaux! Découvrez des informations précieuses sur l'observation des oiseaux et les techniques d'alimentation, partagez vos meilleures captures Birdfy et contemplez des oiseaux exotiques du monde entier !



Birdfy FB Community



@birdfy by netvue

Warning

FCC Statement

Note: This equipment has been tested and found to comply with the limits for a Class B digital device, pursuant to part 15 of the FCC Rules. These limits are designed to provide reasonable protection against harmful interference in a residential installation. This equipment generates, uses and can radiate radio frequency energy and, if not installed and used in accordance with the instructions, may cause harmful interference to radio communications. However, there is no guarantee that interference will not occur in a particular installation. If this equipment does cause harmful interference to radio or television reception, which can be determined by turning the equipment off and on, the user is encouraged to try to correct the interference by one or more of the following measures:

- Reorient or relocate the receiving antenna.
- Increase the separation between the equipment and receiver.
- Connect the equipment into an outlet on a circuit different from that to which the receiver is connected.
- Consult the dealer or an experienced radio/TV technician for help.

This device complies with part 15 of the FCC Rules. Operation is subject to the following two conditions: (1) This device may not cause harmful interference, and (2) this device must accept any interference received, including interference that may cause undesired operation.

Any changes or modifications made without explicit approval from the responsible party in compliance may result in the user being unauthorized to operate the device.

This device meets the FCC radiation exposure limits for uncontrolled environments. To ensure safe installation and operation, maintain a minimum distance of 20cm between the radiator and your body.

FCC ID: 2BC96NI-8441

IC Statement

This device contains licence-exempt transmitter(s)/receiver(s) that comply with Innovation, Science and Economic Development Canada's licence-exempt RSS(s). Operation is subject to the following two Economic Development Canada's licence-exempt RSS(s). Operation is subject to the following two conditions:

- (1) This device may not cause interference.
- (2) This device must accept any interference, including interference that may cause undesired operation of the device.

L'émetteur/récepteur exempt de licence contenu dans le présent appareil est conforme aux

WARNING

CNR d'Innovation, Sciences et Développement économique Canada applicables aux appareils radio exempts de licence. L'exploitation est autorisée aux deux conditions suivantes:

1. L'appareil ne doit pas produire de brouillage;
2. L'appareil doit accepter tout brouillage radioélectrique subi, même si le brouillage est susceptible d'en compromettre le fonctionnement.

This equipment complies with IC radiation exposure limits set forth for an uncontrolled environment. This transmitter must not be co-located or operating in conjunction with any other antenna or transmitter. This equipment should be installed and operated with a minimum distance of 20cm between the radiator and your body.

Cet équipement respecte les limites d'exposition au rayonnement IC établies pour un environnement non contrôlé.

Cet émetteur ne doit pas être localisé ou fonctionner en conjonction avec une autre antenne ou un autre émetteur. Cet équipement doit être installé et utilisé à une distance minimale de 20cm entre le radiateur et votre corps.

NETVUE INC.

1055 East Colorado Boulevard,
5th Floor, Pasadena, CA, 91106

+1(866)749-0567

support@birdfy.com



Icamera International Trading Co., Ltd

Unit G25 Waterfront Studios

1 Dock Road, London, United Kingdom

support@birdfy.com



eVatmaster Consulting GmbH

Raiffeisen Street 2B11, 63110,

Rodgau, Hessen, Germany

support@birdfy.com



*These addresses are not intended for returns. If you have any questions regarding returns or repairs, please contact us at **support@birdfy.com**.

*Estas direcciones no están destinadas para devoluciones. Si tienes alguna pregunta sobre devoluciones o reparaciones, contáctanos en **support@birdfy.com**.

*Ces adresses ne sont pas destinées aux retours. Si vous avez des questions concernant les retours ou les réparations, veuillez nous contacter à **support@birdfy.com**.



1. Contains batteries, keep away from fire.
 2. Battery withstandable use/storage/transport temperature: 14–113°F (-10–45°C).
 3. Replacing the battery with an incorrect type may cause a safety hazard.
 4. Disposing of battery in fire/oven, or crushing/cutting it, may cause explosion.
1. Contiene baterías, mantener alejado del fuego.
 2. Temperatura soportada por la batería para uso, almacenamiento o transporte: 14–113°F (-10–45°C).
 3. Reemplazar la batería con un tipo incorrecto puede representar un riesgo de seguridad.
 4. Desechar la batería en fuego/horno o aplastarla/cortarla puede causar una explosión.
1. Contient des piles, tenir à l'écart du feu.
 2. Température supportée par la batterie en utilisation, stockage ou transport : -10–45°C (14–113°F).
 3. Remplacer la batterie par un type incorrect peut présenter un danger pour la sécurité.
 4. Jeter la batterie au feu/au four ou l'écraser/la couper peut provoquer une explosion.



Brand: Birdfy

Product Name: Birdfy Feeder Bamboo

Model: NI-8441/ NI-8442

FCC ID: 2BC96NI-8441

IC: 31482-NI8441

Manufacturer: NETVUE INC.

1055 East Colorado Boulevard 5th Floor,

Pasadena, CA, 91106

+1(866) 749-0567

support@birdfy.com

Made in China

Designed in USA



Contact us



support@birdfy.com
(Global)



In-App Chat
(Global)



1(866)749-0567
(US Only)

www.birdfy.com

© Netvue Inc.