

The logo for ELLE DECOR is centered within a white square with a black border. The word "ELLE" is written in a large, bold, black serif font on the top line, and "DECOR" is written in a smaller, black serif font on the bottom line.

ELLE
DECOR

Sofa

ASSEMBLY INSTRUCTIONS

Guidelines

Thank you for selecting an Elle Decor Collection piece!

Our primary objective is to provide fast, friendly customer service to all of our customers. We are here to help if you have any questions, comments, or are in need of warranty replacement parts.

Please call us toll free at: 1-855-372-2315
(Monday - Friday 6:00am - 5:00pm PST)

Or visit our website:
www.truecustomersupport.com
www.trueinnovations.com

Or call us toll free: **1-800-379-9773**

FAILURE TO FOLLOW THESE WARNINGS WHEN IN USE COULD RESULT IN INJURY

- Do not stand on the item or use as a step ladder
- The piece has been tested and approved for users weighing up to 250 lbs (113kg) per seat.
- Do not use this item unless all bolts and screws are firmly secured and fastened.
- Check all bolts and screws every 90 days. As necessary tighten if any are loose.
- Lift up then move. Pushing over or dragging this product can result in an injury or cause damage to the floor and piece.

Pre-Assembly Preparation:

Please read through this instruction booklet before beginning assembly of this item.

Two adults are recommended for assembly.

- Clear out the space for assembly and lay out all parts on Parts List, extra room will allow you to easily determine if all the pieces are present.
- Save all packing materials until assembly is complete to avoid accidentally discarding smaller parts or hardware.
- Keep small parts and pieces away from children and pets until fully assembled.
- Please check for any loose screws and tighten them before you use.

WARNING: DO NOT LET CHILDREN PLAY IN OR AROUND THE UNIT DUE TO THE POSSIBLE RISK OF INJURY.

Parts List



A 2.5" Thumb Bolts (2)



B 1-3/4" Thumb Bolts (1)

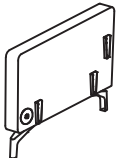

C1 Arms

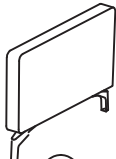

C2 Arms

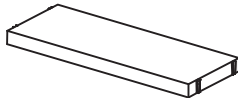

D Seat Frame (1)

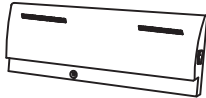

E Back Frame (1)

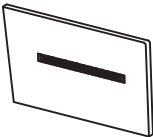

F Back Panel (2)

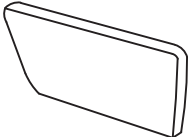

G Arms Rest (2)

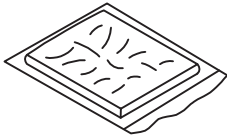

H Seat Cushions (2)



I Seat Cushion Covers (2)



J Pillows (2)

Step 1-- Remove all parts from the carton and place them on a protected surface or carpet. Place the Seat Frame (D) upside down and open the bottom flap. Take the Thumb Bolts (A & B), Seat Cushion (H) x 2, Seat Cushion Cover (I) x 2, Back Panel (F) x 2 out of the seat box.

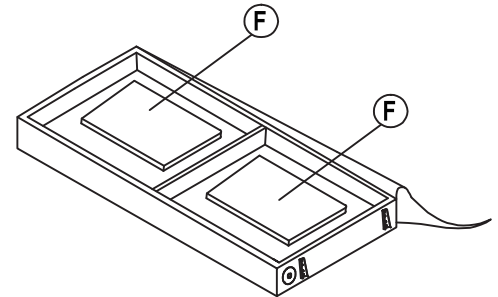
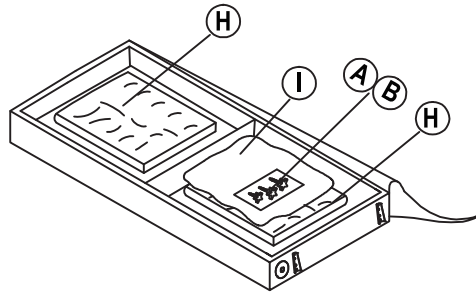
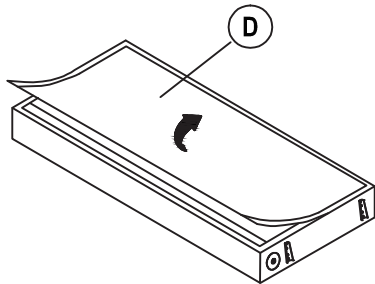

Step 2--

Attach Seat Frame (D) to Arm (C2) by sliding the receivers into the mechanism posts located on sides of Arm (C2), press down Seat Frame (D) then move Seat Frame (D) to attach to the Arm (C1), press down on both sides of the Seat Frame (D) to firmly secure.

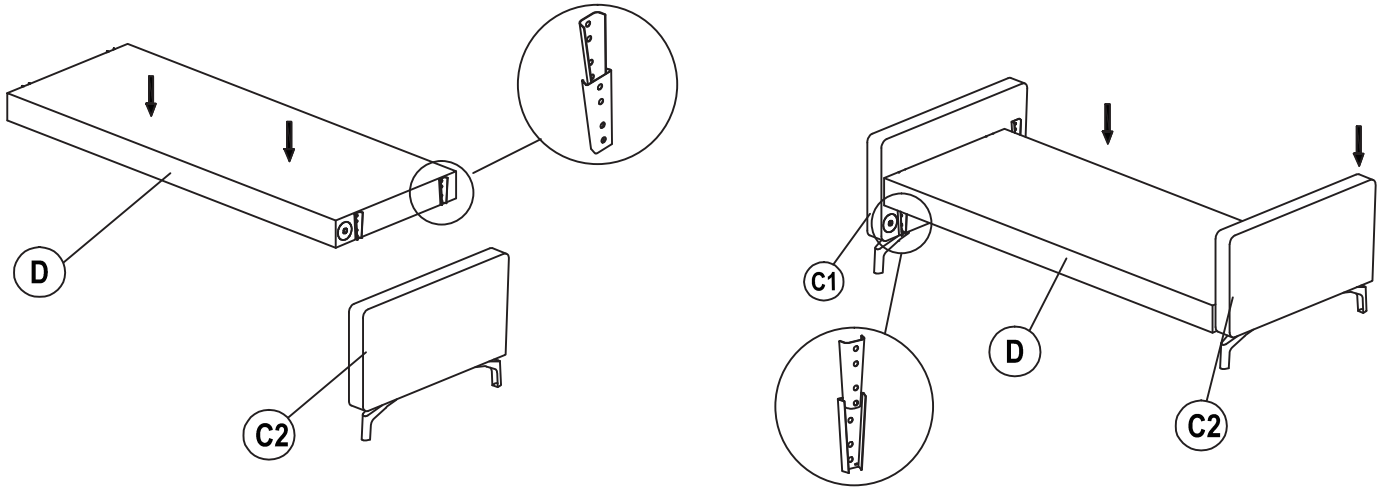

Step 3--

Attach the Back Frame (E) to the Seat Frame (D) by sliding the receivers into the mechanism posts located on the Arms (C1 & C2). From the front of the sofa, press down on both sides of the Back Frame (E) with two hands firmly to secure. The Back Frame (E) and Seat Frame (D) will automatically lock into place.

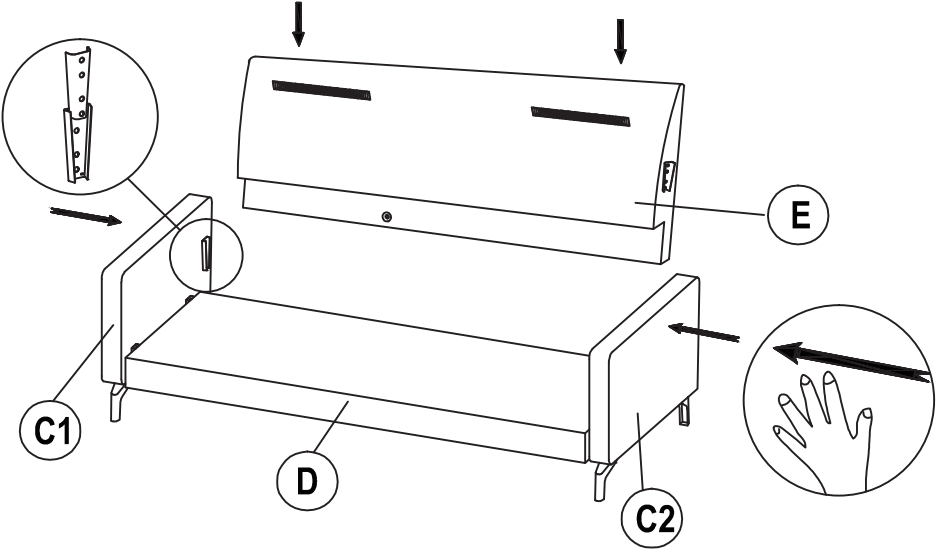

- Step 4--** 1.Insert Thumb Bolts -2.5" (A) x 2 into seat frame holes to sides of Seat Frame (D) and tighten the bolts.
- 2.Insert Thumb Bolt -1-3/4" (B) into seat frame holes to sides of Seat Frame (D) and tighten the bolt.
- 3.Secure the bottom flap with hook and loop tape.

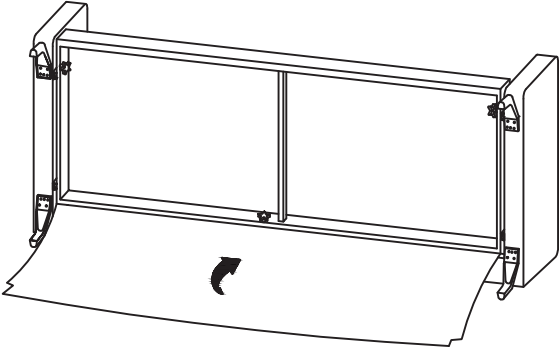
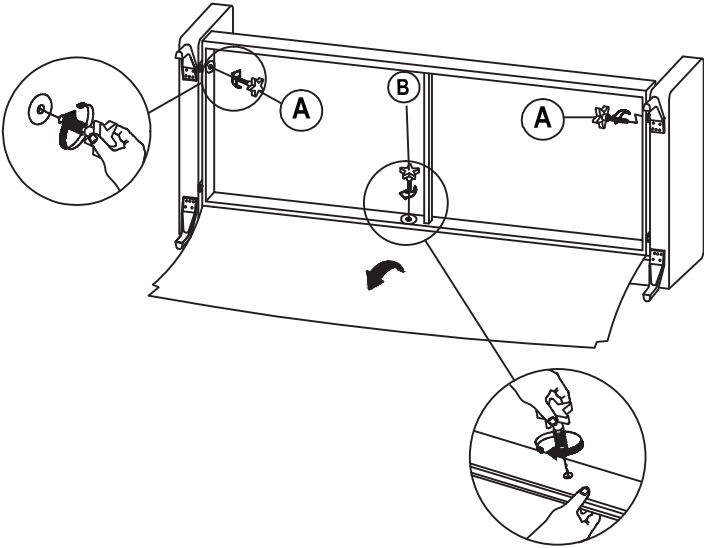

Step 5--

1. Attach Back Panels (F) x 2 to Back Frame (E).
2. Attach Arm Rests (G) x 2 beside Arms (C1&C2).

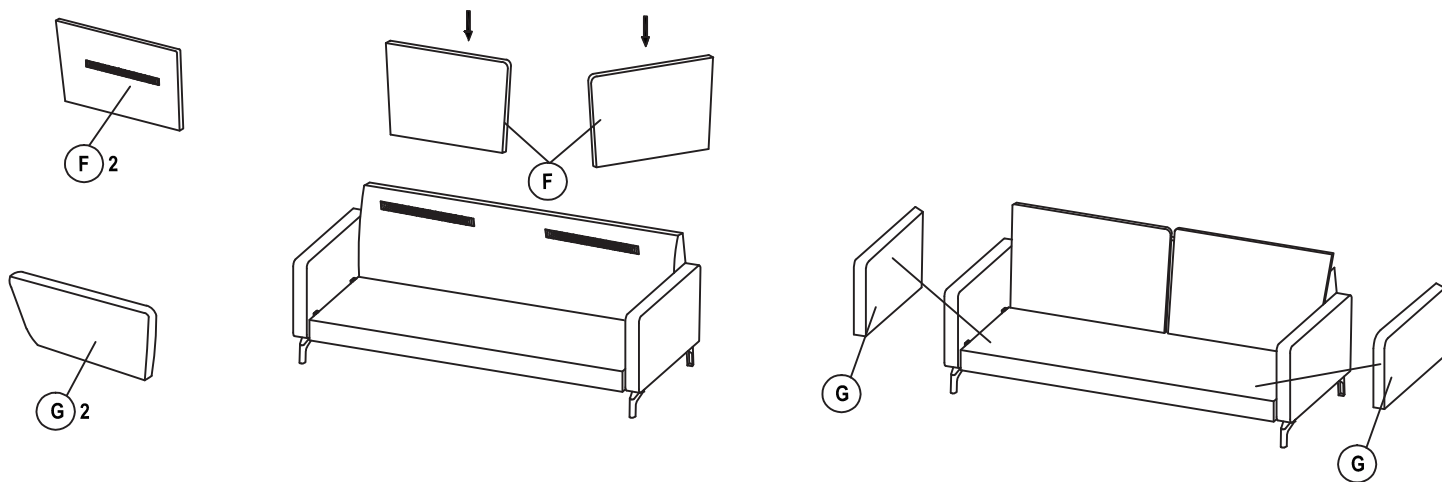

Step 6--

1. Open the vacuum packed Seat Cushion (H) by carefully cutting the bags with a pair of scissors. Insert the Seat Cushion (H) into the appropriate Seat Cover (I). Ensure the cushion cover completely covers the filler as image (2) When closing the zipper as image (3) the cushion is compressed. This will allow the zipper to close with ease. Fluff all cushions and pillows to allow them to expand.

2. Lastly, position all Cushions on the sofa. Seat and back cushions may take 24-48 hours to fully expand, which will allow wrinkles and indentations caused by packing to fade.

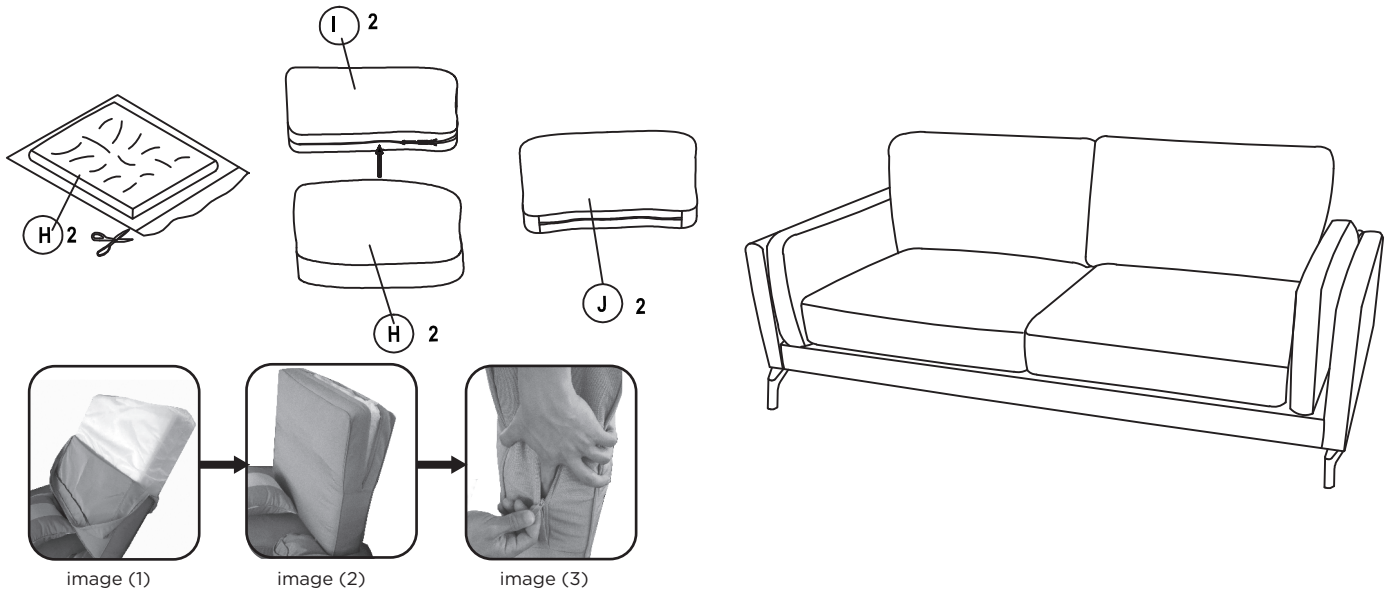

Limited Warranty

Millwork Holdings seating products are warranted against defects in material and workmanship while owned by the “Original Purchaser”. The term “Original Purchaser” is defined as that party or entity which purchases Millwork Holdings furniture from an authorized Millwork Holdings retailer as shown by the original sales receipt. This warranty does not apply to “as is” or previously owned seating products.

Millwork Holdings warrants its products to be free from defects in materials and workmanship (normal wear and tear, fading and stretching excepted), for one year from the date of purchase, except as provided below under the limited warranty.

This warranty gives you specific rights, and you may also have other rights, which vary from state to state. All warranties are limited to the original purchaser for normal use by a maximum of two users. Total weight capacity per chair is 250 pounds for a single user.

The exceptions or exclusions to this warranty are:

- Upholstery material and foam cushion material is warranted against defects in material and workmanship for a period of one year, beginning on the date of purchase as shown on the original sales receipt.
- Any warranty claim that is submitted after the limited warranty period, or without proper proof of purchase will not include the cost of parts, labor, or delivery on the warranted parts within a reasonable amount of time. We reserve the right to require damaged parts to be returned to us upon request. Natural markings such as scars, brands, grain variations, wrinkles, color variations, etc. will be considered normal characteristics and not construed as defects.
- For claims or questions concerning this warranty, please contact Millwork Holdings Customer Service department on the web at www.truecustomersupport.com. Be prepared to provide your name, address, daytime phone number, the model and purchase order number of the product, date of purchase, and the store where it was purchased. Millwork Holdings requires that the original sales receipt be submitted with all requests to confirm that you are the original purchaser according to our written warranty.