

TT-531B

**3 SPEED TURNTABLE WITH BT RECEIVER
AND BUILT-IN SPEAKER**

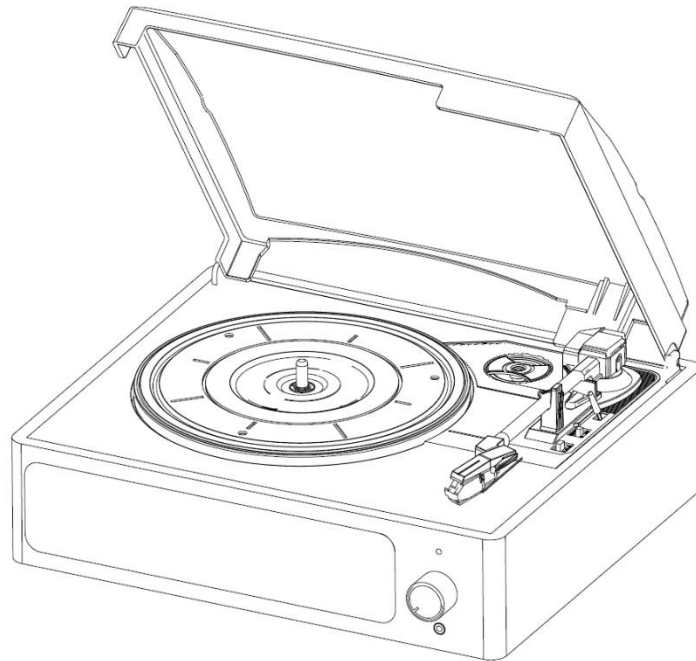

INSTRUCTION MANUAL

READ THIS INSTRUCTION MANUAL CAREFULLY BEFORE USE

PRODUCT FEATURES

- 33/45/78 RPM SELECTABLE TURNTABLE
- AUTOMATIC / MANUAL STOP TURNTABLE
- BELT DRIVEN SYSTEM
- BT RECEIVER
- RCA LINE-OUT
- STEREO BUILT-IN SPEAKER
- 45RPM ADAPTOR & EXTERNAL POWER ADAPTOR INCLUDED

LOCATION OF CONTROL

- 1) 45 RPM ADAPTOR
- 2) LIFT LEVER (FOR RECORD PLAY / PAUSE)
- 3) AUTO STOP ON/OFF BUTTON
- 4) TONE-ARM LOCK
- 5) 33/45/78 RPM SPEED SELECTOR
- 6) CARTRIDGE
- 7) TURNTABLE PLATTER
- 8) DUST COVER
- 9) POWER INDICATOR
- 10) POWER/VOLUME KNOB
- 11) EARPHONE JACK
- 12) SPEAKER
- 13) EXTERNAL POWER ADAPTOR JACK
- 14) RCA LINE-OUT JACK
- 15) BT BUTTON

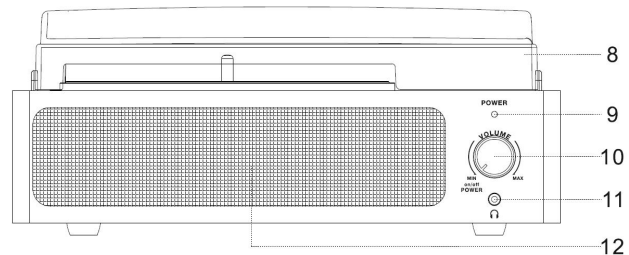
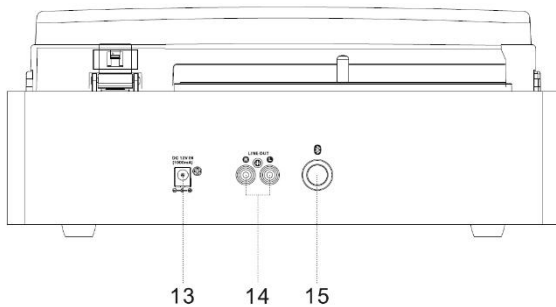
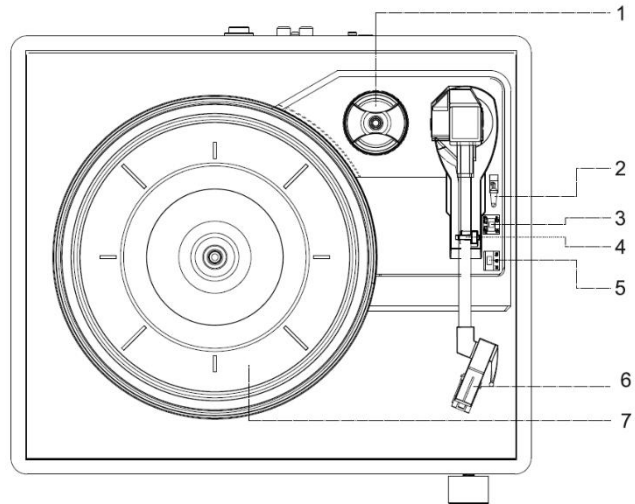

CAUTION:

USAGE OF CONTROLS OR ADJUSTMENTS OR PERFORMANCE OF PROCEDURES OTHER THAN THOSE SPECIFIED HEREIN MAY RESULT IN HAZARDOUS RADIATION EXPOSURE. THIS UNIT SHOULD NOT BE ADJUSTED OR REPAIRED BY ANYONE EXCEPT QUALIFIED SERVICE PERSONNEL.

PRECAUTIONS FOR USE

INSTALLATION

- UNPACK ALL PARTS AND REMOVE PROTECTIVE MATERIAL.
- DO NOT CONNECT THE UNIT TO THE MAINS BEFORE CHECKING THE MAINS VOLTAGE AND BEFORE ALL OTHER CONNECTIONS HAVE BEEN MADE.
- DO NOT COVER ANY VENTS AND MAKE SURE THAT THERE IS A SPACE OF SEVERAL CENTIMETERS AROUND THE UNIT FOR VENTILATION.

CONNECTION

1. CONNECT EXTERNAL POWER ADAPTOR WITH **EXTERNAL POWER ADAPTOR JACK** AND THE POWER SOURCE.
2. TURN THE POWER KNOB TO SWITCH ON THE UNIT. IF THE **POWER INDICATOR** LIGHTS UP, IT MEANS THE POWER SUPPLY IS NORMAL, NOW YOUR SYSTEM IS READY FOR USE.

PHONO

NOTED:

- REMOVE THE STYLUS PROTECTOR.
- BE SURE THAT THE TONE ARM IS BEING DETACHED FROM THE **TONE-ARM LOCK** BEFORE OPERATING AND RE-SECURED AGAIN AFTERWARDS.

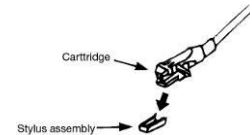

1. SET THE **SPEED SELECTOR** TO THE PROPER POSITION DEPENDING ON THE RECORD TO BE PLAYED.
2. PLACE THE RECORD ON THE PLATTER, USE THE 45 RPM ADAPTOR IF REQUIRED.
3. PUSH THE **LIFT LEVER** UPWARD TO RAISE THE TONE ARM FROM THE ARM PARK, AND THEN SLOWLY MOVE IT TO THE RECORD SIDE. THE PLATTER WILL START TO ROTATE.
4. PUT DOWN THE **LIFT LEVER** TO DROP THE TONE ARM AND TOUCH THE RECORD GENTLY. PHONO PLAYING STARTS NOW.
5. PUSH THE **LIFT LEVER** UPWARD TO RAISE THE TONE ARM FROM THE ARM PARK, NOW PLATTER WILL STILL BE ROTATING BUT PHONO PLAYING WILL STOP. TO CONTINUE THE PLAYING, THE USER NEEDS TO PUT DOWN THE **LIFT LEVER**.
6. ADJUST THE VOLUME TO THE DESIRED LEVEL.
7. AT THE END OF RECORD, THE PLATTER WILL AUTOMATICALLY STOP ROTATING. PUSH THE **LIFT LEVER** UPWARD TO RAISE THE TONE ARM AND MOVE IT TO THE ARM PARK, AND THEN PUT DOWN THE **LIFT LEVER**.
8. TO STOP MANUALLY, LIFT THE TONE ARM FROM THE RECORD AND RETURN IT TO THE ARM PARK.

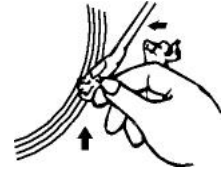

REMARK : AS SOME KIND OF RECORD THE AUTO-STOP AREA WAS OUT OF THE UNIT SETTING, SO IT WILL STOP BEFORE THE LAST TRACK FINISHES. IN THIS CASE, SELECT THE **AUTO-STOP SWITCH** TO “ OFF “ POSITION, THEN IT WILL RUN TO THE END OF THE RECORD BUT WILL NOT STOP AUTOMATICALLY (TURN OFF THE UNIT BY **POWER BUTTON** OR SWITCH BACK THE **AUTO-STOP SWITCH** TO “ ON “ POSITION TO STOP THE PLATTER ROTATE). THEN PUT BACK THE TONE ARM TO THE ARM PARK.

EARPHONE JACK & LINE OUT SOCKET

- THIS SYSTEM CAN BE CONNECTED WITH HEADPHONE OR EXTERNAL AMPLIFIER / SPEAKER BY 3.5MM **EARPHONE JACK**.
- THIS SYSTEM CAN BE CONNECTED WITH EXTERNAL DEVICE (EG. AMPLIFIER AND SPEAKER) BY **RCA LINE-OUT JACK** AT REAR CABINET.

BT RECEIVER

- THIS SYSTEM CAN BE CONNECTED WITH EXTERNAL BT SOURCE (LIKE MOBILE PHONE) TO PLAY MUSIC.
- PRESS **BT BUTTON** AT BACK PANEL TO CONTROL THE BT RECEIVER FUNCTION. SWITCH ON THE BT FUNCTION OF YOUR BLUETOOTH DEVICE (LIKE MOBILE PHONE), AND SELECT “TT-531B” BT EQUIPMENT FOR CONNECTION.:
 - **BT BUTTON INDICATOR FLASHING RAPIDLY:** READY TO CONNECT.
 - **BT BUTTON INDICATOR STAY ON:** ALREADY CONNECTED WITH EXTERNAL BT SOURCE (LIKE MOBILE PHONE)
 - **BT BUTTON INDICATOR OFF:** PRESS **BT BUTTON** AGAIN TO DISCONNECT EXTERNAL BT SOURCE, BT IS DISCONNECTED.

ENERGY SAVING

IF THERE IS NO AUDIO SIGNAL FROM TURNTABLE FOR OVER 10 MINUTUES, THE UNIT WILL AUTOMATICALLY SWITCH TO STANBY MODE FOR ENERGY SAVING.