

AIRMOSEN

2-IN-1 DRIP COFFEE MAKER



USER MANUAL

*HOUSEHOLD USE ONLY

If you are having problems using this 2-in-1 drip coffee maker
Please email : service@airmsen.com or call 1-844-725-2333
for assistance : www.airmsen.com

To best serve you, our AIRMOSEN Representatives are available to answer your calls Monday to
Friday, 10:30 AM - 6:30 PM EST.

THANK YOU FOR MAKING AIRMOSEN APPLIANCES A PART OF YOUR HOME.

*HOME APPLIANCES

CONSTANT INNOVATION TO ALLOW CONSUMERS TO GET BETTER PRODUCTS

Take “technology, innovation, health” as its core value, to be the preferred brand of household products in your healthy and quality life.

AIRMOSEN focus on researching, developing and manufacturing various kinds of household supplies with advanced technologies and the idea of sustainable development, to promote the evolution and transform of our lifestyle, to make it more healthy, green, intelligent and with high quality, and to bring a happy, healthy and eco-friendly home life to around the world.

SAFETY

Your safety and the safety of others is very important.

We have provided many important safety messages in this manual and on your appliance. Always read and obey all safety messages.



This is the safety alert symbol.

This symbol alerts you to potential hazards that can cause serious injury to you and others.

All safety messages will follow the safety alert symbol.

All safety messages will tell you what the potential hazard is, tell you how to reduce the chance of injury, and tell you what can happen if the instructions are not followed.

CONTENTS

IMPORTANT SAFEGUARDS	04
SAFETY INSTRUCTIONS	04
PRODUCT PARAMETERS	05
COMPONENT OVERVIEW	06
CONTROL PANEL DESCRIPTION	07
MODE DESCRIPTION	09
CONTROL PANEL STATUS OVERVIEW	10
BEFORE FIRST USE	11
COFFEE BREWING INSTRUCTIONS	12
COFFEE BEAN GRINDING & BREWING	12
GROUND COFFEE BREWING	14
DELAY START BUTTON INSTRUCTIONS	16
KEEP WARM INSTRUCTIONS	18
CLEANING AND DAILY MAINTENANCE	19
DAILY CLEANING (AFTER EACH USE)	19
MAIN UNIT CLEANING	19
MAINTENANCE FOR LONG PERIODS OF NON-USE	19
WATER TANK FILTER CLEANING	20
USAGE TIPS	20
DESCALING RECOMMENDATIONS	20
DESCALING INSTRUCTIONS	21
TROUBLESHOOTING	23
WARRANTY	25
CUSTOMER SUPPORT	26

IMPORTANT SAFEGUARDS

Congratulations on your purchase of the new AIRMSEN 2-IN-1 DRIP COFFEE MAKER. This user manual contains important information regarding the installation, use, and maintenance of this machine. Please spend some time reading this manual to make the best use of all functions of this multifunctional electric steamer.

SAFETY INSTRUCTIONS

To reduce the risk of fire, electric shock, and/or personal injury, please always stick to the following basic safety precautions when using this machine:

BASIC SAFETY WARNINGS

1. **Read all instructions before use and retain them for future reference.**
2. **Do not immerse the power cord, plug, or main unit in water or any other liquid**, as this may result in electric shock.
3. **Close supervision is required** when this appliance is used by or near children, elderly persons, or individuals with limited mobility.
4. This appliance is **not intended for use by persons with reduced physical, sensory, or mental capabilities**, unless they are supervised or instructed by a responsible person.
5. **Always turn off the appliance and ensure your hands are dry** when plugging in or unplugging the power cord.
6. **Do not operate the appliance if the power cord is damaged, the unit malfunctions, or has been damaged in any way.** (Contact Customer Support at service@airmsen.com.)

OPERATIONAL SAFETY

1. **Place the appliance on a stable, level, and heat-resistant surface during use.**
2. **Do not move or tilt the appliance while it is operating.**
3. **Keep the appliance out of reach of children** to prevent tipping or burns.
4. **Do not touch hot surfaces, the water outlet, or areas exposed to hot water during operation**, as they may cause burns.
5. **After brewing is complete, the filter and surrounding metal components remain hot. Do not touch them directly.**
6. **Keep hands and all body parts away from hot water, steam, and the brewing outlet.**
7. **The top lid and surrounding areas become hot during operation. Do not touch the lid.**
8. **Do not use accessories or attachments not recommended by the manufacturer**, as this may cause injury or damage.
9. **Do not operate the appliance near flammable materials**, such as paper towels, cloths, or solvents.

CLEANING AND MAINTENANCE SAFETY

1. **Always turn off and unplug the appliance before cleaning, and allow it to cool completely.**
2. **Do not use metal brushes, abrasive cleaners, or corrosive cleaning agents.**
3. **The main unit must not be immersed in water.** Clean only with a damp cloth.
4. **Clean the Water Tank and Filter regularly** to maintain coffee quality and optimal performance.
5. If the appliance will not be used for an extended period, **empty the Water Tank and keep the unit dry.**
6. **Do not attempt to disassemble or repair the appliance yourself.**
7. For maintenance other than cleaning or descaling, **contact Customer Support at service@airmsen.com.**

POWER SUPPLY AND ENVIRONMENTAL SAFETY

1. **Ensure the voltage matches the rated voltage shown on the product nameplate.**
2. **Do not use damaged, loose, or unstable electrical outlets.**
3. **Keep the power cord away from heat sources.**
4. **When unplugging, grasp the plug firmly—do not pull on the power cord.**
5. **Do not use the appliance outdoors, in damp environments, or near sinks.**
6. **Do not place or operate the appliance on unstable surfaces.**

TRANSPORTATION AND STORAGE SAFETY

1. **Before moving the appliance, ensure all hot water, coffee grounds, and internal pressure have been fully released.**
2. **Store the appliance in a cool, dry place away from direct sunlight.**
3. **Do not place heavy objects on top of the appliance or its accessories.**

PRODUCT PARAMETERS

Power Voltage	Power	Water Tank Capacity
120V~, 60Hz	900W	26.38Oz / 780ml

COMPONENT OVERVIEW

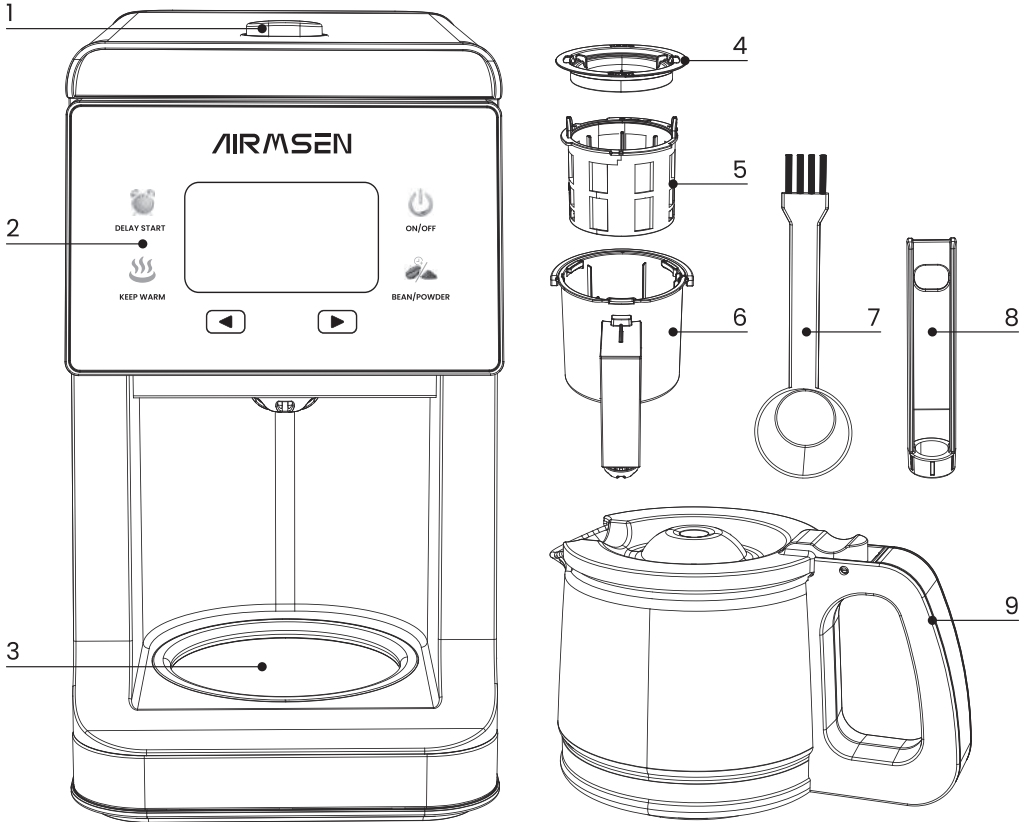

1. Top Lid Release Button
2. Control Panel
3. Warming Plate / Heating Plate
4. Filter Basket Lid
5. Removable Filter Basket
6. Filter Basket Assembly
7. Measuring Scoop: approx. 1 tablespoon (≈ 6 g)

8. Water Tank Filter
9. Glass Carafe

To purchase accessories, please visit: www.airmsen.com

Note: The product images are for reference only. Please refer to the actual product inside the package.

CONTROL PANEL DESCRIPTION

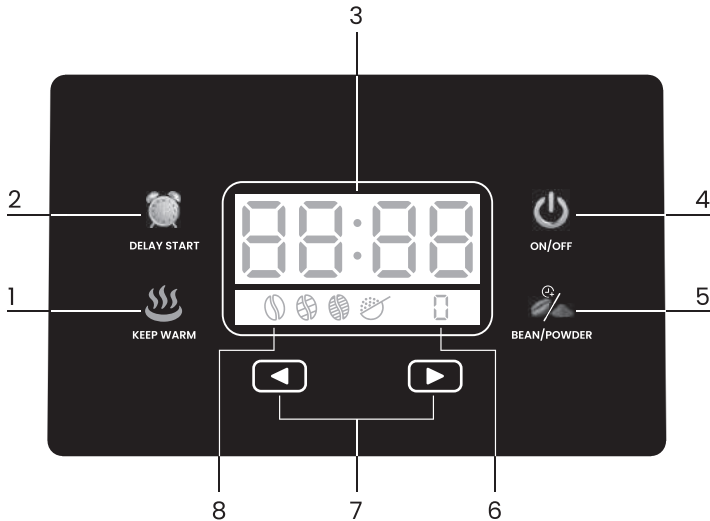





1. KEEP WARM Button

- **Press once:** Activates the **Keep Warm** function; the indicator light remains on.
- **The keep-warm duration is 2 hours**, after which the appliance stops automatically and enters standby mode.

2. Delay Brew / Clock Setting Button

This button is used for Delay Brew and Current Time settings.



Delay Brew Setting:

- Before setting, **select the desired coffee mode using the Bean / Ground Mode Button.**
- **Press the Delay Brew / Clock Button once.** The digital display shows **00:00**, and the **hour digits flash.**
- Use the  /  Time **Adjustment Buttons** to set the hour.
- **Press the button again; the minute digits flash.** Use  /  to adjust the minutes.
- **Press once more to confirm. The Delay indicator icon remains lit, indicating that the setting is complete.**
- When the preset time is reached, **the coffee maker will start brewing automatically.**

Notes:

- If the setting is not confirmed, the system will exit automatically after 10 seconds of inactivity, and the delay brew function will be canceled.
- During the delay period, press the Delay Brew / Clock Button  or the Power Button again to cancel the delay brew.

Current Time Setting

- Press and hold the Delay Brew / Clock Button for 2 seconds to enter clock setting mode.
- When the hour digits flash, use  /  to adjust the hour.
- Press once briefly to switch to minute adjustment.
- Press once more to confirm, or wait 10 seconds for automatic saving and return to standby mode.

3. Display Description

- **Left side of the digital display:** Displays the **hour**.
- **Right side of the digital display:** Displays the **minutes**.
- **During operation:** The display shows the **current time**.
- **During Delay Brew or Keep Warm mode:** The display shows the **remaining countdown time**.

4. Power / Start / Stop Button



- **When powered off:** Press once to enter **Standby Mode**.
- **In Bean or Ground Mode:** Press once to **start or stop brewing**.
- **In other modes:** Press once to **stop the current operation only**.
- **Press and hold for 3 seconds:** Power off the appliance.

5. Bean / Ground Mode Button

Used to select the coffee preparation mode.

- **Each short press** switches to the next mode and is accompanied by a beep.
- **When switching modes**, the corresponding mode indicator flashes.

Notes:

- When using **whole coffee beans**, select **Grind Mode**, which includes **Coarse**  / **Medium**  / **Fine**  grind settings.
- When using **ground coffee**, select **Ground Coffee Mode**. In this mode, **no grinding is performed**, and the machine proceeds directly to brewing.

6. Descaling Indicator Light

- **When the coffee maker has been used 500 times, the Descaling Indicator Light will remain on**, signaling that **descaling is required**.

- **After the descaling reminder appears, the coffee maker can still be used normally;** however, it is **recommended to perform descaling promptly** to prevent limescale buildup, which may affect **appliance performance or coffee taste.**

7. Time Adjustment Buttons

Used to adjust **Delay Brew Time** or **Current Time.**

- Adjustable parameters: **Hours or Minutes.**





Operation:

- **Short press:** Increase or decrease values step by step.
- **Press and hold:** Rapid continuous adjustment.

8. Bean / Ground Indicator Lights

When a coffee mode is selected, the corresponding indicator light will flash.

Indicator Light Descriptions:

-  **Coarse Grind Indicator.**
-  **Medium Grind Indicator.**
-  **Fine Grind Indicator.**
-  **Ground Coffee Indicator.**

Safety Notices

If the top lid is not fully closed, the Start Button cannot activate the appliance.

If the top lid is accidentally opened during operation, the appliance will stop automatically to ensure user safety.

MODE DESCRIPTION

Grind Mode:

- The appliance first **grinds the coffee beans,** then **automatically proceeds to the brewing process.**





Ground Coffee Mode:

- **Grinding is bypassed,** and the appliance **brews directly.**

After Brewing:

- The appliance **automatically enters Keep Warm mode** for **2 hours by default,** then **switches to Standby Mode.**

CONTROL PANEL STATUS OVERVIEW

Button / Function	Status	Icon Indicator	Display / Behavior
 ON/OFF	Standby	Icon ON (steady)	Appliance is ready
	Operating (any mode)	Icon blinking	Brewing or active function in progress
 DELAY START	Setting	Icon ON (steady)	Hour digits flash on digital display
	Setting confirmed	Icon ON (steady)	Remaining delay start time displayed
	Operating	Icon OFF	Power button blinks rapidly, display shows current time
	Standby	Icon OFF	/
 KEEP WARM	Keep Warm active	Icon ON (steady)	Power button blinks rapidly, display shows remaining keep warm time
	Standby	Icon OFF	/
 BEAN/POWDER	Mode switching	Selected mode icon blinks	Mode selection in progress
	Operating	Selected mode icon ON (steady)	Power button blinks rapidly
	Standby	Icon OFF	/

BEFORE FIRST USE

Before using this appliance for the first time, or after a long period of non-use, please follow the steps below to ensure safe operation, proper performance, and optimal coffee flavor.

1. Unpack and Check Components

Remove the coffee maker and all accessories from the packaging. **Ensure that all components are present and free from damage.**

If any parts are missing or damaged, **do not operate the appliance** and contact Customer Support at service@airmsen.com

2. Clean Removable Parts

Remove and clean the following components:

- **Glass Carafe**
- **Removable Filter Basket**
- **Filter Basket Lid**
- **Measuring Scoop**

Rinse all parts thoroughly with clean water and **allow them to air dry completely.** Once dry, **reinstall all components correctly in their original positions.**

3. Position the Coffee Maker

Place the coffee maker on a **stable, dry, level, and heat-resistant surface.**

Keep the appliance **away from heat sources and water,** and **out of reach of children** to ensure safe use.

COFFEE BREWING INSTRUCTIONS



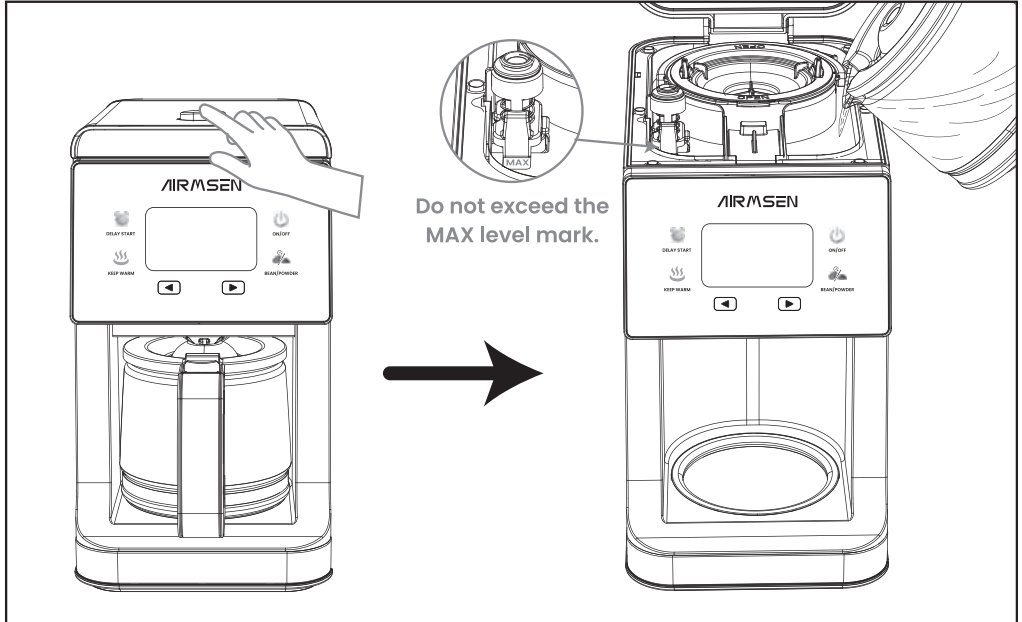

COFFEE BEAN GRINDING & BREWING

1. Add Water

- Press the **Top Lid Release Button** to open the **Top Lid**.
- Fill the **Water Tank** with potable water. **Do not exceed the MAX level mark.**
- Refer to the **graduation marks on the Glass Carafe** to control the desired brew amount.



2. Add Coffee Beans

- Remove the **Filter Basket Assembly** and lift the **Filter Basket Lid**.
- Rotate the **Filter Basket counterclockwise** until the **“Unlock”**  icon aligns with the **“triangle indicator”**  icon. When a **“click”** sound is heard, pull upward to remove the Filter Basket.
- Add an appropriate amount of **whole coffee beans** into the Filter Basket.
- Recommended amount: approximately **5 tablespoons** (about **5 scoops** using the included **Measuring Scoop**).
- Reinsert the Filter Basket into the Filter Basket Assembly. Align the **“Unlock”**  icon on the Filter Basket with the **triangle indicator** on the assembly, then rotate **clockwise** to the **“Lock”**  icon. A **“click”** sound indicates the basket is properly locked.
- Close the **Filter Basket Lid** and place the assembled Filter Basket Assembly back into the coffee maker.
- Close the **Top Lid** and **ensure it is fully closed.**

Note: Do not allow coffee beans to fall into the Water Tank.

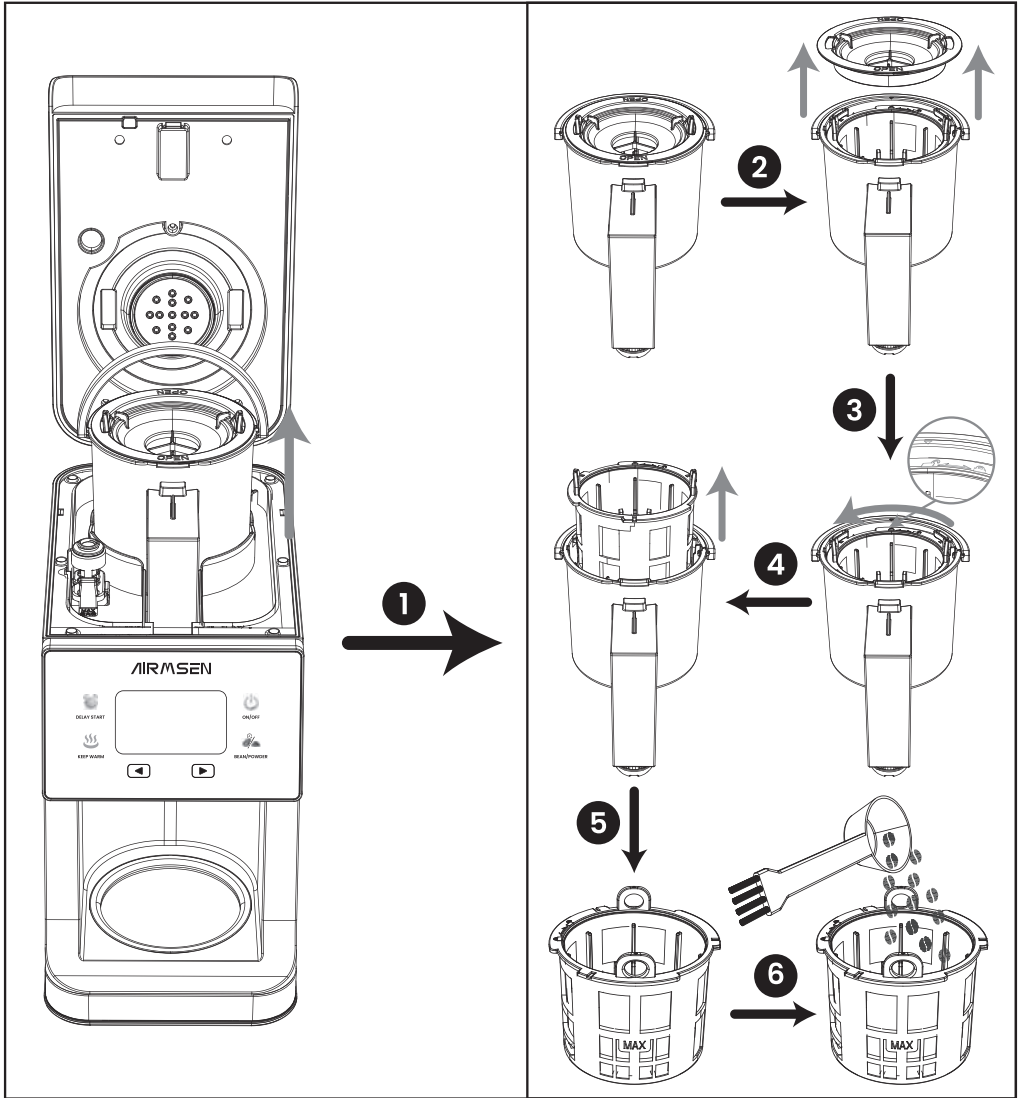

3. Select Bean Mode

- Plug in the appliance.
- Press the **Bean / Powder**  **Mode Button** to select **Bean Mode**. The corresponding indicator icon will **blink**.

4. Start Brewing

- Press the **ON/ OFF Button**  to begin operation.
- The appliance will **grind the coffee beans first**, then **automatically start the brewing process**.

5. Completion and Keep Warm

- After brewing is complete, the coffee maker will **automatically enter Keep Warm mode** for **2 hours by default**.
- Once the Keep Warm cycle ends, the appliance will **automatically switch to Standby mode**.
- To restart Keep Warm, press the **Keep Warm Button**  while the appliance is in **Standby mode** to activate another **2-hour Keep Warm cycle**.

Usage Tips

- **Do not open the Top Lid during brewing**, or the appliance will **automatically stop**.
- To stop brewing during operation, press the **ON/OFF Button** to cancel the current cycle.
- **After use, promptly discard the brewed coffee and clean the appliance.**

GROUND COFFEE BREWING



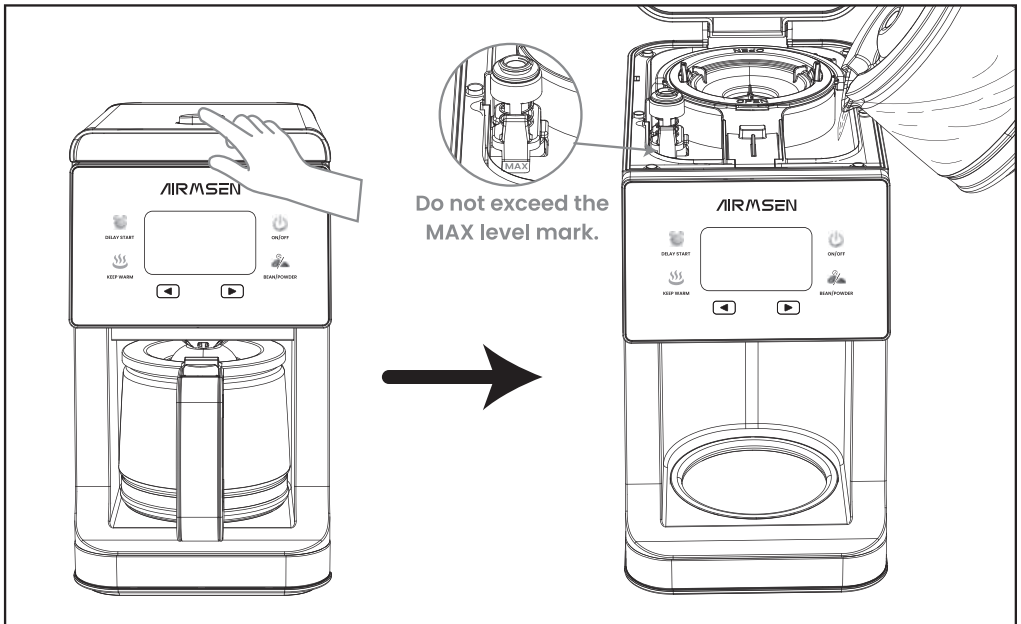

1. Add Water

- Press the Top Lid Release Button to open the Top Lid.
- Fill the Water Tank with potable water. Do not exceed the MAX level mark.
- Refer to the graduation marks on the Glass Carafe to control the desired brew amount.



2. Add Ground Coffee

- Remove the **Filter Basket Assembly** and lift the **Filter Basket Lid**.

- Rotate the **Filter Basket** **counterclockwise** until the “**Unlock**  ” icon aligns with the “**triangle indicator**  ” icon. When a “**click**” sound is heard, pull upward to remove the Filter Basket.
- Add an appropriate amount of **ground coffee** into the Filter Basket.
- Recommended amount: approximately **5 tablespoons** (about **5 scoops** using the included **Measuring Scoop**).
- Reinsert the Filter Basket into the Filter Basket Assembly. Align the “**Unlock**  ” icon on the Filter Basket with the **triangle indicator** on the assembly, then rotate **clockwise** to the “**Lock**  ” icon. A “**click**” sound indicates the basket is properly locked.
- Close the **Filter Basket Lid** and place the assembled Filter Basket Assembly back into the coffee maker.
- Close the **Top Lid** and **ensure it is fully closed**.

Note: Do not allow ground coffee to fall into the Water Tank.

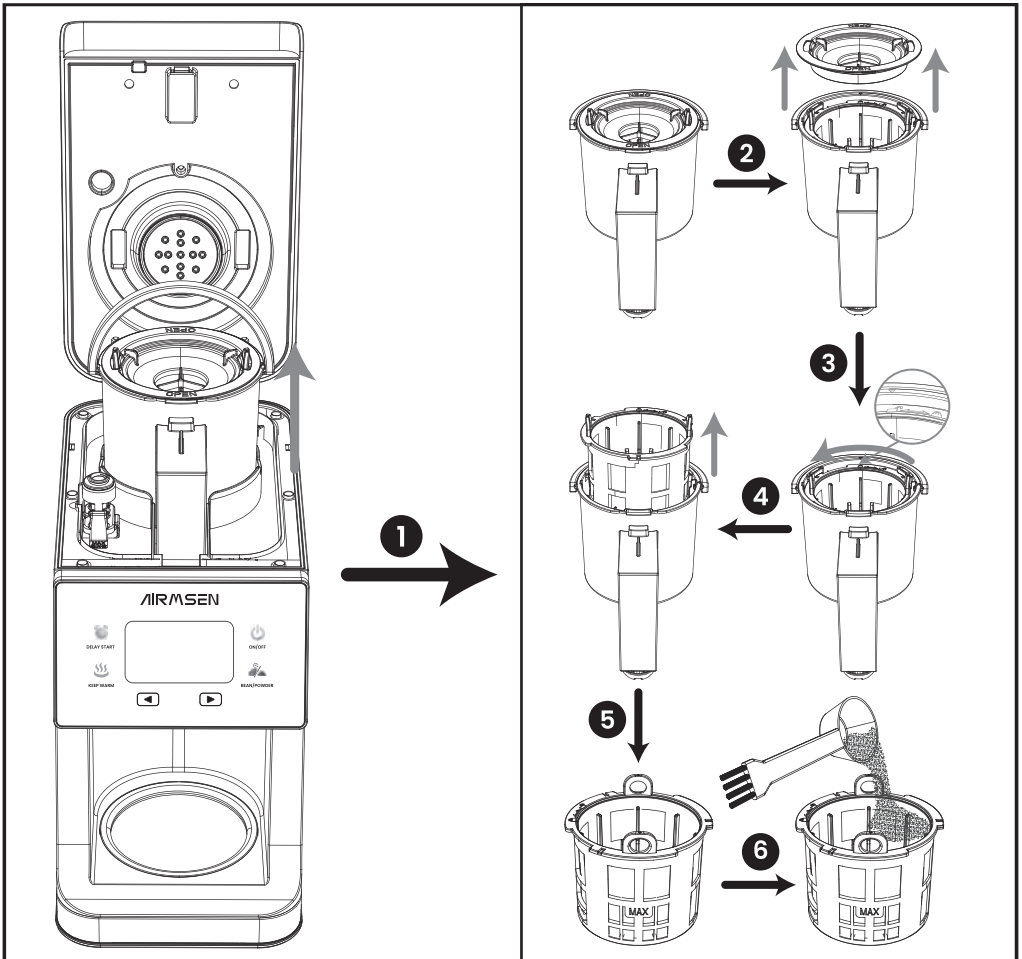

3. Select Powder Mode

- Plug in the appliance.
- Press the **Bean / Powder**  **Mode Button** to select **Powder Mode**. The corresponding indicator icon will **blink**.

4. Start Brewing

- Press the **ON/OFF Button**  to begin operation.
- In this mode, **no grinding is performed**; the appliance **enters the brewing process directly**.

5. Completion and Keep Warm

- After brewing is complete, the coffee maker will **automatically enter Keep Warm mode for 2 hours by default**.
- Once the Keep Warm cycle ends, the appliance will **automatically switch to Standby mode**.
- To restart Keep Warm, press the **Keep Warm Button**  while the appliance is in **Standby mode** to activate another **2-hour Keep Warm cycle**.

Usage Tips

- **Do not open the Top Lid during brewing**, or the appliance will **automatically stop**.
- To stop brewing during operation, press the **ON/OFF Button**  to cancel the current cycle.
- **After use, promptly discard the brewed coffee and clean the appliance.**

DELAY START BUTTON INSTRUCTIONS

The Delay Brew function allows you to preset the start time so the coffee maker automatically begins brewing at the scheduled time.

Setting Delay Brew

1. Select Brewing Mode

Before setting Delay Brew, press the **Bean / Powder**  **Mode Button** to select the desired brewing mode.

2. Enter Delay Setting

- **Short press** the **Delay Start**  **Button** once.
- The digital display shows **00:00**, and the **hour digits begin to flash**.

3. Set the Hour

- Use the **Time Adjustment Buttons**   to set the desired hour.

4. Set the Minutes

- **Short press** the **Delay Start**  **Button** again; the **minute digits flash**.
- Use the **Time Adjustment Buttons**   to adjust the minutes.

5. Confirm Delay Time

- **Short press** the **Delay Start**  **Button** once more to confirm.
- **When the Delay indicator icon remains lit, Delay Brew has been set successfully.**

6. Automatic Start

- At the scheduled time, the coffee maker will **automatically turn on and begin brewing.**

7. Completion and Keep Warm

- After brewing is complete, the coffee maker will **automatically enter Keep Warm mode for 2 hours by default.**
- Once Keep Warm ends, the appliance will **automatically switch to Standby mode.**
- To restart Keep Warm, press the **Keep Warm**  **Button** while in **Standby mode** to activate another **2-hour Keep Warm cycle.**

Notes

- **If no operation is performed within 10 seconds during setup, the system will exit the setting mode automatically and Delay Brew will be canceled.**
- **During the delay period, pressing the Delay Start**  **Button or the Power Button will cancel Delay Brew.**

Setting the Current Time

1. Enter Time Setting Mode

- **Press and hold** the **Delay Start**  **Button** for **2 seconds** to enter current time setting mode.
- **The hour digits on the digital display will flash.**

2. Set the Hour

- Use the **Time Adjustment Buttons**   to adjust the current hour.

3. Set the Minutes

- **Short press** the **Delay Start**  **Button** again; the **minute digits will flash.**
- Use the **Time Adjustment Buttons**   to adjust the current minutes.

4. Confirm the Time

- **Short press** the button once more to confirm, or wait **10 seconds with no operation** to save automatically.
- The appliance will return to **Standby mode.**



Tips

- **As long as the appliance remains powered, the current time does not need to be reset.**
- **Set the current time during first use or after a power interruption.**

KEEP WARM INSTRUCTIONS

This appliance features both **Automatic Keep Warm** and **Manual Keep Warm** functions to maintain coffee temperature after brewing is complete.

1. Automatic Keep Warm

- After brewing is complete, the coffee maker will **automatically enter Keep Warm mode**.
- The **default Keep Warm duration is 2 hours**.
- During Keep Warm operation, the **Keep Warm  indicator icon remains lit**, the **ON/OFF  button indicator blinks rapidly**, and the **digital display shows the remaining Keep Warm time**.
- When Keep Warm ends, the appliance will **automatically stop heating and switch to Standby mode**.

2. Manual Keep Warm

If additional warming is required after Automatic Keep Warm ends, follow the steps below:

- **Ensure the Glass Carafe is properly placed on the Warming Plate / Heating Plate.**
- While the appliance is in **Standby mode**, **short press the Keep Warm Button **.
- The appliance will **restart the Keep Warm function** for another **2 hours**.
- After the Keep Warm cycle ends, the appliance will **automatically return to Standby mode**.

Usage Tips

- **Do not touch the Warming Plate / Heating Plate during Keep Warm operation**, as it becomes hot and may cause burns.
- To end Keep Warm early, press the **ON/OFF  Button** to cancel the current operation.
- **It is recommended to keep coffee in the Glass Carafe during Keep Warm** to prevent dry heating, which may reduce product lifespan.
- **If the Top Lid is not fully closed, the Keep Warm function cannot be activated.**

CLEANING AND DAILY MAINTENANCE

To ensure proper operation and extend the service life of the coffee maker, **clean the appliance after each use and perform regular maintenance.**

Before Cleaning



- **Always turn off the appliance and unplug the power cord before cleaning.**
- **Allow the coffee maker and all components to cool completely before cleaning.**
- **Do not immerse the appliance, power cord, or plug in water,** as this may cause electric shock or damage.

DAILY CLEANING (AFTER EACH USE)

Glass Carafe

- Discard any remaining coffee.
- Wash with warm water and a mild detergent using a **soft cloth or sponge.**
- Rinse thoroughly and **allow to air dry completely.**

Removable Filter Basket and Filter Basket Lid

- Open the **Top Lid** and remove the **Filter Basket Assembly,** (Please refer to the **Coffee Brewing Instructions on page 10).**
- Remove the Filter Basket according to the “**Unlock**  / **Lock**  ” icons.
- Discard used coffee grounds. Rinse the Filter Basket and Filter Basket Lid with clean water; use a **soft brush** if necessary.
- After cleaning, **reinstall all parts correctly in their original positions.**

Filter Basket Assembly

- The Filter Basket Assembly can be removed as a whole and rinsed with clean water.
- **Ensure it is completely dry** before placing it back into the coffee maker.

MAIN UNIT CLEANING

- Wipe the exterior of the appliance with a **dry or slightly damp soft cloth.**
- **Do not use steel wool, abrasive cleaners, or corrosive liquids.**
- **Do not rinse the main unit directly with water.**

MAINTENANCE FOR LONG PERIODS OF NON-USE

- Clean all removable components and **allow them to dry completely.**
- Ensure **no water remains in the Water Tank.**
- Store the coffee maker in a **dry, well-ventilated place.**

WATER TANK FILTER CLEANING

This appliance is equipped with a **Water Tank Filter** to prevent impurities from entering the internal system. **Regular cleaning is recommended** to ensure proper water flow and extend product lifespan.

Cleaning Steps

- Open the **Top Lid** and remove the **Water Tank Filter**.
- Rinse the filter under clean running water to remove debris or mineral deposits.
- If necessary, gently clean with a **soft brush**.
- After cleaning, **reinstall the filter securely in its original position**.

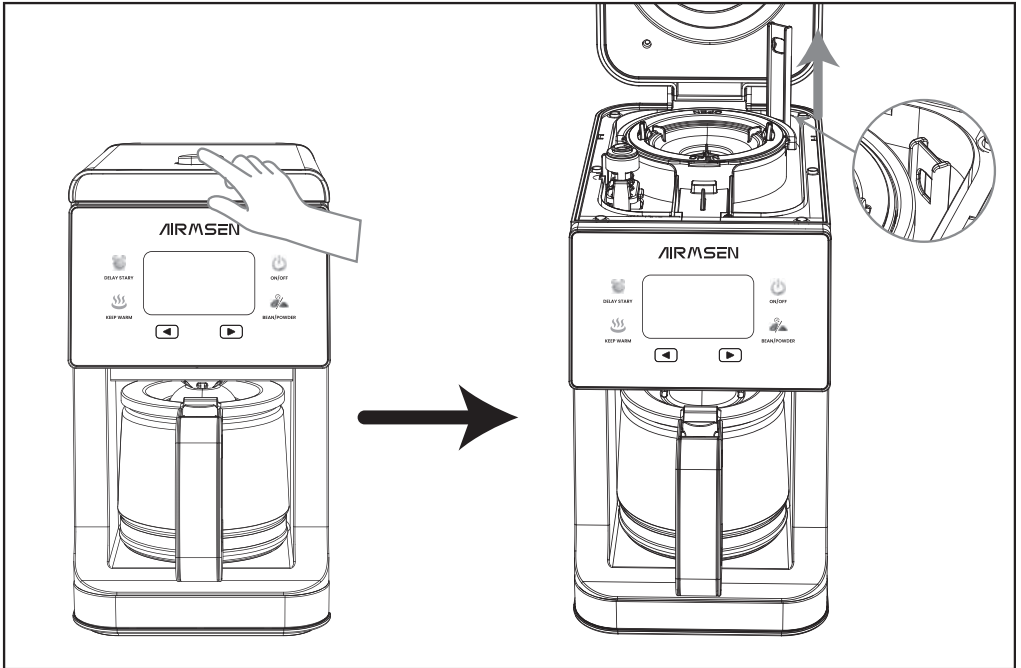

USAGE TIPS

- **Remove used coffee grounds after each use** to prevent residue buildup, off-flavors, or blockage.
- If you notice **unusual odors or abnormal water flow**, perform an internal water rinse or a descaling procedure.

DESCALING RECOMMENDATIONS

- To prevent mineral buildup that may affect performance and coffee flavor, **regular descaling is recommended**.
- Under normal use, the coffee maker will **prompt for descaling after**

approximately 500 brewing cycles.

- When the **descaling indicator appears on the display**, the appliance can still be used; however, **descaling should be performed as soon as possible.**
- In areas with **hard water**, it is recommended to **shorten the descaling interval**, even if the indicator has not appeared.
- Failure to descale regularly may result in **reduced water flow, decreased heating efficiency, or poor coffee taste.**

DESCALING INSTRUCTIONS

To maintain proper operation and ensure optimal coffee flavor, **regular descaling is recommended.**

This appliance is equipped with a **built-in 500-cycle descaling reminder** to prompt timely maintenance.

1. Descaling Reminder



- After the coffee maker has been operated **500 times**, the “” indicator in the **lower-right corner of the digital display remains lit**, indicating that **descaling is required.**
- When the descaling reminder appears, the coffee maker **can still be used normally**; however, **descaling should be performed as soon as possible** to prevent mineral buildup from affecting performance or taste.

2. Entering Descaling Mode

Prepare the Descaling Solution

- Fill the **Water Tank** with clean water up to the **MAX** level.
- Add descaling solution at a **1:3 ratio** (or prepare according to the descaler manufacturer's instructions).

Start Descaling Mode

- While the appliance is in **Standby mode**, **press and hold both Time Adjustment**   **Buttons simultaneously** to enter **Descaling mode.**
- The **Descaling indicator remains lit**, and the “” indicator in the **lower-right corner of the display blinks**, indicating that **Descaling mode has started.**

3. Descaling Process

- Once Descaling mode is activated, the coffee maker will **automatically begin the descaling cycle.**
- During operation, the **Descaling indicator blinks**, and the appliance completes the internal descaling process according to a preset program.
- After descaling is complete, the appliance will emit **three “DI” beep sounds** and **automatically switch to Standby mode (the Keep Warm function will not activate).**
- At the same time, the **descaling reminder indicator turns off**, and the **500-cycle counter is reset.**

4. Rinse with Clean Water

After descaling, **a clean water rinse is required** to remove any remaining descaling solution:

- Fill the **Water Tank** with clean water up to the **MAX** level.
- Press the **Power / Start Button** to run one complete brewing cycle.
- **It is recommended to repeat the clean water rinse once more** to ensure the internal system is thoroughly flushed.

Usage Tips

- **Do not add coffee beans, ground coffee, or any other substances to the Water Tank during descaling.**
- **Use only descaling agents suitable for coffee makers.** Do not use highly corrosive cleaners.
- In areas with **hard water**, it is recommended to **shorten the descaling interval**, even if the reminder has not appeared.

Important Notes

- **Do not disconnect the power or open the Top Lid during the descaling process.**
- **Failure to perform the clean water rinse after descaling may affect coffee flavor.**

TROUBLESHOOTING

Problem: The coffee maker does not start

Possible Causes:

- The power plug is not properly inserted.
- The electrical outlet has no power.
- The **Top Lid** is not fully closed.

Solutions:

- **Check that the power plug is securely inserted.**
- **Try another outlet or check the power supply.**
- **Ensure the Top Lid is fully closed, then restart the appliance.**

Problem: No water flow or abnormal water flow

Possible Causes:

- The **Water Tank** is empty or water level is insufficient.
- Foreign objects are present in the Water Tank.
- The appliance requires descaling.

Solutions:

- **Fill the Water Tank with clean water to an appropriate level.**
- **Clean the Water Tank and remove any foreign objects.**
- **Refer to the Descaling Instructions on page 18 to perform descaling.**

Problem: Brewing does not start (Delay Brew not working)

Possible Causes:

- The delay time was not confirmed.
- No operation was performed for more than **10 seconds** during setup.

Solutions:

- **Reset and confirm the Delay Brew time.**
- **After setup, make sure the Delay indicator  icon is steadily lit or breathing, indicating the setting is active.**

Problem: The coffee maker stops automatically during operation

Possible Causes:

- The **Top Lid** was opened during operation.
- Brewing was manually canceled by the user.

Solutions:

- **Close the Top Lid and restart the appliance.**
- **Check whether the ON/OFF  Button was pressed accidentally.**

Problem: Grinder does not operate (Bean Mode)

Possible Causes:

- **Bean Mode** is not selected.
- The **Filter Basket** is not installed correctly.

Solutions:

- **Confirm that Bean Mode is selected.**
- **Check that the Filter Basket is properly installed and locked in place.**

Problem: Coffee tastes too weak or too strong

Possible Causes:

- The amount of coffee beans or ground coffee is not appropriate.
- The ratio of water to coffee is incorrect.

Solutions:

- **Adjust the amount of coffee beans or ground coffee.**
- **Adjust the water level according to the desired number of cups.**

Problem: The “” indicator in the lower-right corner of the display remains lit

Possible Cause:

- The appliance has reached the **descaling reminder threshold**.

Solutions:

- **Refer to the Descaling Instructions on page 18 to perform descaling.**
- **After descaling is complete, the indicator will turn off automatically.**

If the problem cannot be resolved using the above solutions, please contact Customer Support at service@airmsen.com.

WARRANTY

Product Name	Model Number	Default Warranty Period	For your own reference, we strongly recommend that you record your order number and date of purchase.
2-IN-1 DRIP COFFEE MAKER	CGM501HB	2 years	

TERMS & POLICY

AIRMOSEN warrants all products to be of the highest quality in material, craftsmanship, and service, effective from the date of purchase to the end of the warranty period.

AIRMOSEN will replace any product found to be defective due to manufacturer flaws based on eligibility. Refunds are available within the first 30 days of purchase. Refunds are only available to the original purchaser of the product. This warranty extends only to personal use and does not extend to any product that has been used for commercial, rental, or any other use in which the product is not intended for. There are no warranties other than the warranties expressly set forth with each product.

This warranty is non-transferrable. AIRMOSEN is not responsible in any way for any damages, losses, or inconveniences caused by equipment failure by user negligence, abuse, or use noncompliant with the user manual or any additional safety or usage warnings included in the product packaging and manual.

THIS WARRANTY DOES NOT APPLY TO THE FOLLOWING:

- Damage due to abuse, accident, alteration, misuse, tampering, or vandalism.
- Improper or inadequate maintenance.
- Damage in return transit.
- Unsupervised use by children under 18 years of age.

AIRMOSEN assume no liability for damage caused by the use of the product other than for its intended use or as instructed in the user manual. Some states do not allow this exclusion or limitation of incidental or consequential losses, so the foregoing disclaimer may not apply to you. This warranty gives you specific legal rights and you may also have other rights, which may vary from state to state.

ALL EXPRESSED AND IMPLIED WARRANTIES, INCLUDING THE WARRANTY OF MERCHANTABILITY, ARE LIMITED TO THE PERIOD OF THE LIMITED WARRANTY.

DEFECTIVE PRODUCTS & RETURNS

Should your product prove defective within the specified warranty period, please contact Customer Support via **service@airmsen.com** with your order number. DO not dispose of your product before contacting us. Once our Customer Support Team has approved your request, please return the unit with a copy of your invoice and order number.

CUSTOMER SUPPORT

WE'RE HERE TO HELP!

If you encounter any issues or have any questions regarding your new product, please contact our helpful Customer Support Team. Your satisfaction is our goal!

CUSTOMER SUPPORT

Email: service@airmsen.com

Telephone: **1-844-725-2333**

*** To best serve you, our AIRMSEN Representatives are available to answer your calls**

Monday to

Friday, 10:30 AM – 6:30 PM EST.

If you need to purchase product accessories, please visit www.airmsen.com.

*** Please have your order confirmation number ready before contacting Customer Support.**



<https://www.facebook.com/Airmsen>



<https://www.youtube.com/@AIRMSEN>

For product operation videos, please subscribe to AIRMSEN's official Youtube account.

AIRMSSEN

QUESTIONS OR COMMENTS?

EMAIL	OR VISIT US ONLINE AT
service@airmsen.com	www.airmsen.com

