

3D  
PRINTER

EN

# USER'S MANUAL

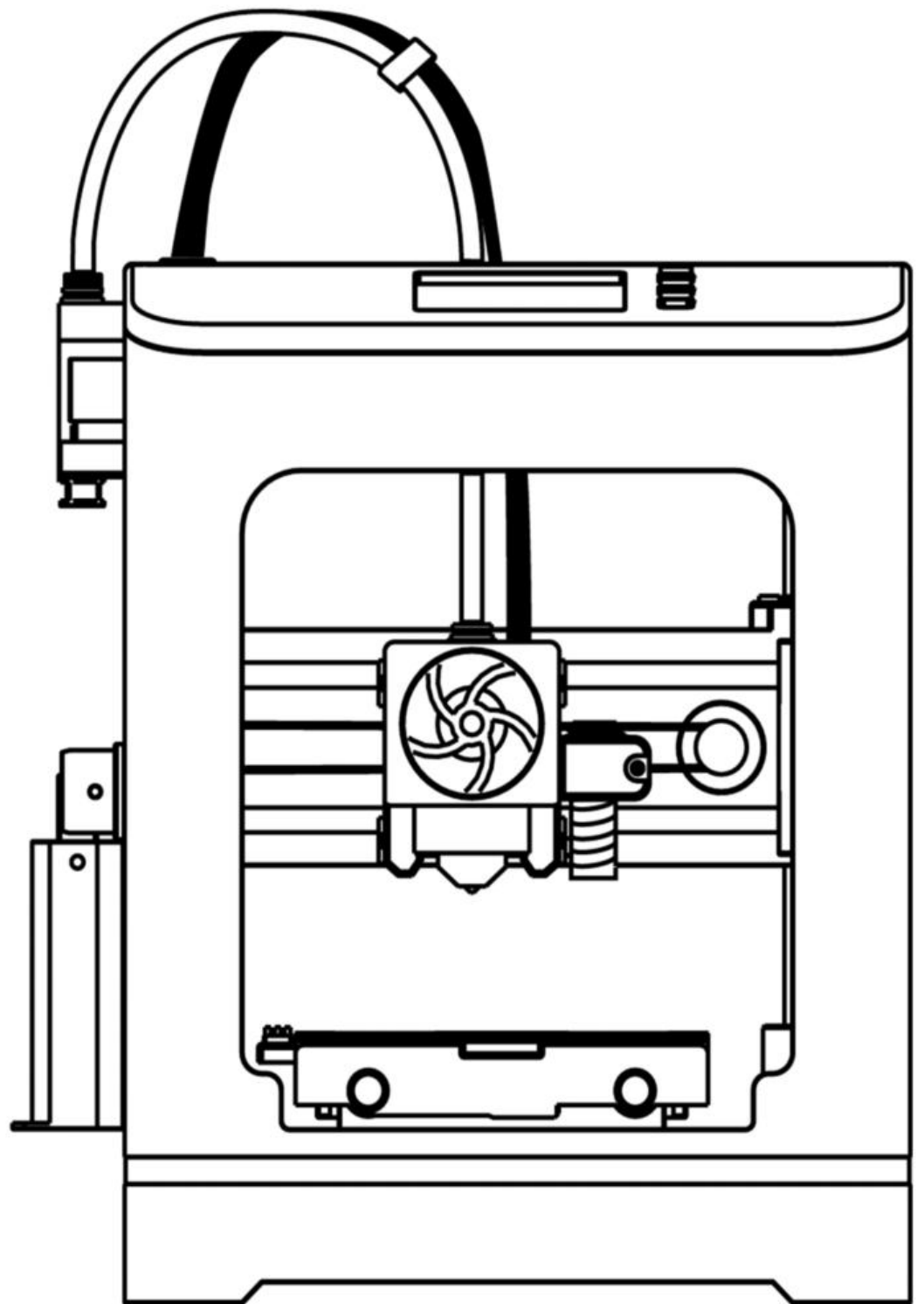

# CONTENTS

|                                 |          |
|---------------------------------|----------|
| <b>1. NOTES</b>                 | <b>3</b> |
| 1.1. Safety Warnings            | 3        |
| 1.2. Filament                   | 4        |
| 1.3. Environmental Requirements | 4        |
| <b>2. INTRODUCTION</b>          | <b>5</b> |
| 2.1. Specification              | 5        |
| 2.2. Product Overview           | 6        |
| 2.3. Hotend Structure           | 6        |
| <b>3. SYSTEM MENU</b>           | <b>7</b> |
| 3.1. Info Screen                | 8        |
| 3.2. Prepare Menu               | 9        |
| 3.2.1. Change Filament          | 9        |
| 3.2.2. Move Axis                | 11       |
| 3.2.3. Homing                   | 13       |
| 3.2.4. Level Bed                | 13       |
| 3.2.5. Endstops                 | 13       |
| 3.2.6. Disable Steppers         | 14       |
| 3.3. Control Menu               | 14       |
| 3.3.1. Temperature              | 14       |
| 3.3.2. Probe Z Offset           | 15       |
| 3.3.3. Homing Params            | 15       |
| 3.3.4. Language                 | 16       |
| 3.3.5. Smart Temperature        | 16       |
| 3.3.6. Powerloss Recover: Off   | 16       |
| 3.3.7. Printer Info             | 17       |
| 3.3.8. TF Card Maintenance      | 17       |
| 3.3.9. Firmware Update          | 18       |
| 3.3.10. WIFI Firmware Update    | 19       |
| 3.3.11. Restore Defaults        | 19       |
| 3.3.12. Advance Settings        | 20       |
| 3.4. WIFI Network               | 21       |
| 3.4.1. WIFI Info                | 21       |

|  |           |
|--|-----------|
| 3.4.2. WIFI QR Code .....  | 22        |
| 3.4.3. Network Test .....  | 22        |
| 3.4.4. Unreg. Cloud .....  | 22        |
| 3.4.5. WIFI Reset .....  | 23        |
| 3.5. Print from TF .....   | 23        |
| 3.5.1. Pause Print .....   | 24        |
| 3.5.2. Stop Print .....  | 24        |
| 3.5.3. Change Filament .....                                       | 24        |
| 3.5.4. Tune .....  | 25        |
| 3.5.5. Save Printing and Off .....                                 | 26        |
| <b>4. COMMON MENU OPERATIONS .....</b>                             | <b>27</b> |
| 4.1. Print from TF Card .....                                      | 27        |
| 4.2. Print Multi-Color Models / Change Filament During Print ..... | 27        |
| 4.3. Adjust Temperature During Print .....                         | 28        |
| 4.4. Adjust Z Offset During Print .....                            | 28        |
| <b>5. PRINT BY APP .....</b>                                       | <b>29</b> |
| <b>6. WIIBUILDER SLICING SOFTWARE .....</b>                        | <b>31</b> |
| 6.1. Installation .....  | 32        |
| 6.2. Interface Introduction .....                                  | 33        |
| 6.3. Select Language .....   | 34        |
| 6.4. Select Printer .....  | 35        |
| 6.5. Add Model .....   | 36        |
| 6.6. Adjust Model .....  | 36        |
| 6.7. Basic Parameter Settings .....                                | 38        |
| 6.8. Send Files via Network .....                                  | 39        |
| 6.9. Send Files via TF Card .....                                  | 41        |
| 6.10. Advanced Parameter Settings .....                            | 41        |
| <b>7. CURA .....</b>   | <b>50</b> |
| 7.1. Installation .....  | 50        |
| 7.2. Interface Introduction .....                                  | 55        |
| 7.3. Add Model .....   | 56        |
| 7.4. Adjust Model .....  | 56        |
| 7.5. Slice .....   | 57        |

# 1.NOTES

PLEASE READ THIS MANUAL BEFORE USING THE DEVICE, PAYING CLOSE ATTENTION TO THE SAFETY WARNINGS AND GUIDELINES. KEEP THIS MANUAL IN A SAFE PLACE FOR FUTURE REFERENCE.

THIS MANUAL IS ONLY APPLICABLE TO TINA2C.

## 1.1.Safety Warnings

- Do not touch the nozzle or stepper motors when the 3D printer is operating or just finished printing, as the nozzle temperature can reach up to 230° C.
- Do not expose this device to water or moisture. Keep liquids away from the device. If moisture gets inside, immediately unplug it and let it fully dry before using again.
- Do not handle the device, power cord, or any cables with wet hands.
- Before use, check the unit and power cord for any damage. Do not use if damage is found.
- Ensure the power outlet provides the proper voltage and current required by the device.
- Unplug the device when not in use.
- Protect the power cord from being crimped, pinched, walked on, or tangled. Ensure the cord does not pose a tripping hazard.
- Always unplug by grasping the plug head or adapter body, never by pulling the cord.
- Turn off and unplug the 3D printer before making repairs or performing service.

### **Warning:**

This device complies with Part 15 of the FCC Rules. Operation is subject to the following two conditions: (1) this device may not cause harmful interference, and (2) this device must accept any interference received, including interference that may cause undesired operation.

Changes or modifications not expressly approved by the party responsible for compliance could void the user's authority to operate the equipment.

NOTE: This equipment has been tested and found to comply with the limits for a Class B digital device, pursuant to Part 15 of the FCC Rules. These limits are designed to provide reasonable protection against harmful interference in a residential installation. This equipment generates, uses and can radiate radio frequency energy and, if not installed and used in accordance with the instructions, may cause harmful interference to radio communications. However, there is no guarantee that interference will not occur in a particular installation.

If this equipment does cause harmful interference to radio or television reception which can be determined by turning the equipment off and on, the user is encouraged to try to correct the interference by one or more of the following measures:

--Reorient or relocate the receiving antenna.

-- Increase the separation between the equipment and receiver

--Connect the equipment into an outlet on a circuit different from that to which the receiver is connected.

--Consult the dealer or an experienced radio/TV technician for help

#### RF Exposure Statement

To maintain compliance with FCC's RF Exposure guidelines, this equipment should be installed and operated with minimum distance of 20cm the radiator your body. This device and its antenna(s) must not be co-located or operation in conjunction with any other antenna nr transmitter.

## 1.2.Filament

To ensure optimal performance, only use filament provided by the manufacturer. Third-party filaments may have inconsistent specifications and quality, potentially clogging or damaging the nozzle and motor. Using unauthorized consumables voids the warranty.Store unused filament in a sealed bag to prevent moisture absorption, which can degrade print quality.

## 1.3.Environmental Requirements

This 3D printer is for indoor use only, with an ideal ambient temperature of 15° C - 25° C.

Below 10° C: Printed models may not adhere properly to the platform.

Below 0° C: The device will not start.

Above 30° C: Print quality will significantly decline and the nozzle may clog.

# 2.INTRODUCTION

## 2.1.Specification

|                          |  |
|--------------------------|--|
| Model                    | TINA2C   |
| Build Volume             | 100 × 100 × 100 mm (3.94" × 3.94" × 3.94")   |
| Nozzle Diameter          | 0.4mm  |
| Layer Thickness          | 0.1-0.4mm  |
| Max Nozzle Temp          | 245°C  |
| Platform Material        | Flexible Spring Steel  |
| Leveling Tech            | 9-Point Auto Bed Leveling  |
| Max Print Speed          | 70mm/s Manual adjustment up to 150 mm/s may result in significant quality degradation. |
| Print Precision          | ±0.1mm   |
| Product Weight           | 2.5 kg (5.51 lbs)  |
| Power Supply             | 110V-240V, 12V, 48W  |
| Filament Diameter        | 1.75mm   |
| Supported Filament       | PLA / TPU  |
| Filament Holder Capacity | 1kg  |
| Slicing Software         | WiiBuilder (Windows / macOS)<br>Cura (Windows / macOS)<br>Kiri (ChromeOS / iPadOS)     |
| Input File Format        | STL / OBJ / AMF  |
| Print Format             | G-code   |
| Input Method             | App / TF Card / Wi-Fi / Type-C   |
| APP                      | Poloprint Cloud (Android / IOS)  |

## 2.2.Product Overview

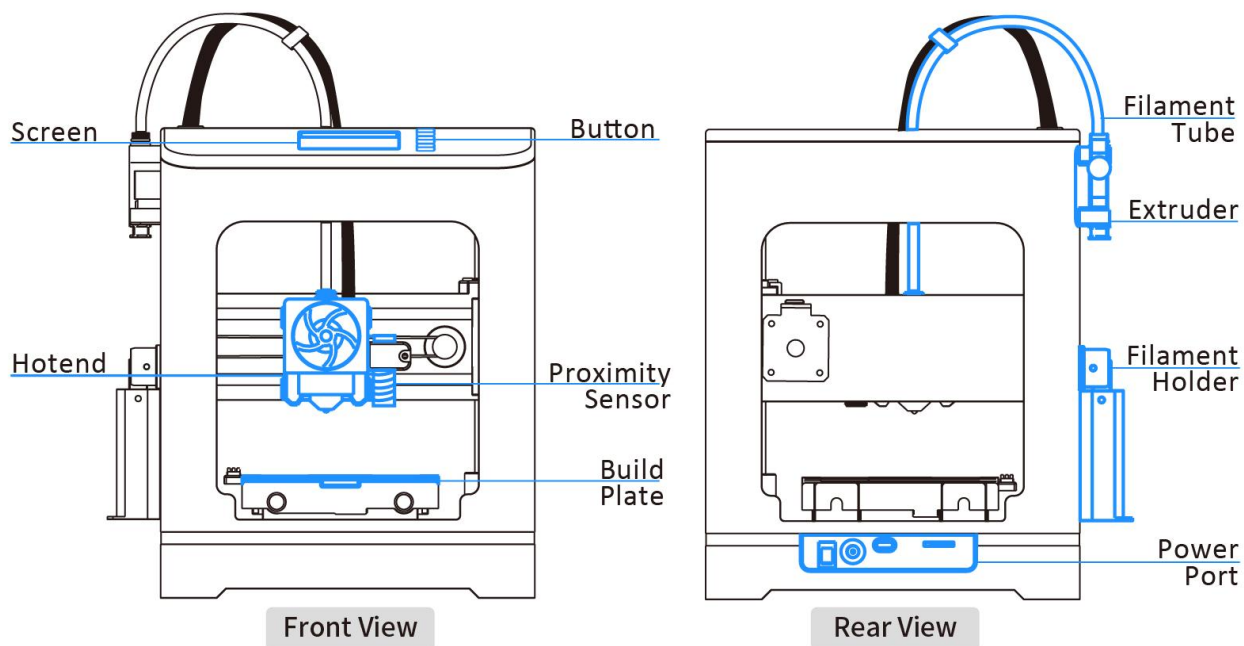

## 2.3.Hotend Structure

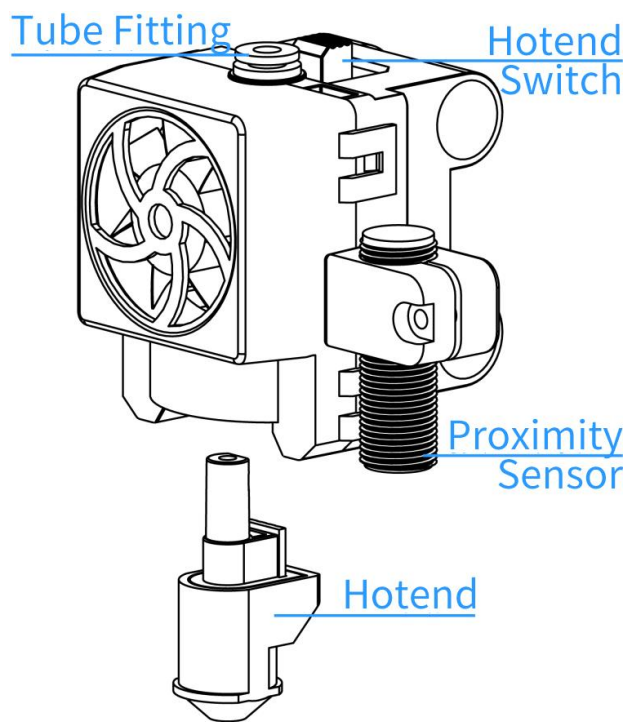

# 3.SYSTEM MENU

The 3D printer’s control panel is equipped with an LCD screen and three buttons: “^”, “↵”, and “v”. Their functions are as follows:

- “^” BUTTON: Move up
- “↵” BUTTON: Confirm or enter the selected menu item
- “v” BUTTON: Move down

The device menu consists of FOUR LEVELS. The top level is the MAIN MENU, followed by the corresponding SUB-MENUS at each level.

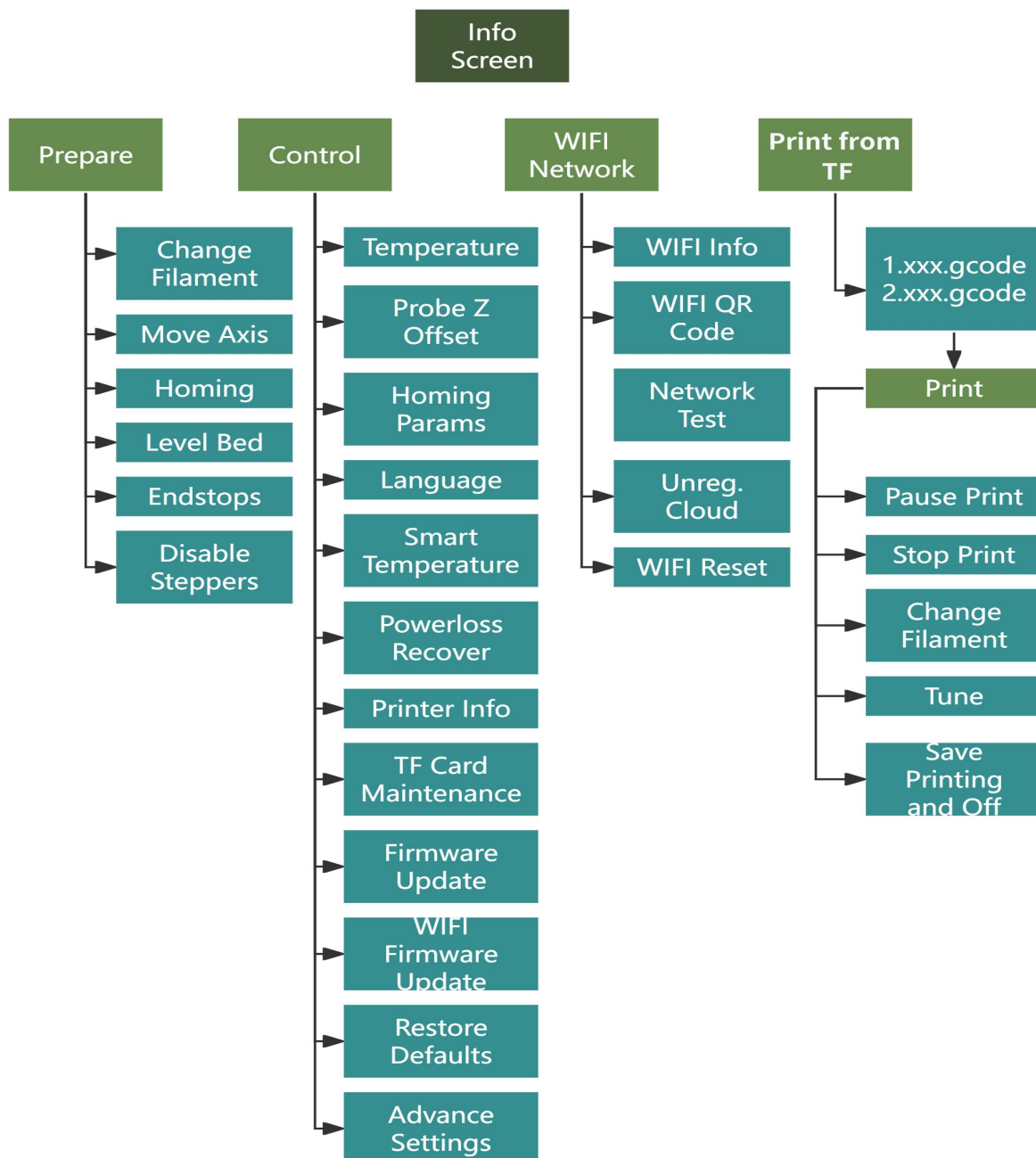

### 3.1.Info Screen

After powering on, the device enters the Home Screen.

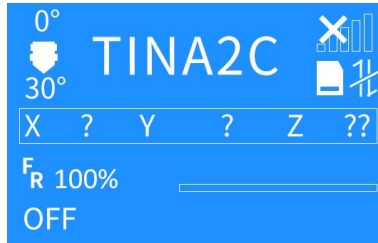

The Info Screen displays the status of the printer’s main components and key printing information, as described below:





- **NOZZLE TEMPERATURE:**

The upper value indicates the TARGET TEMPERATURE, and the lower value indicates the CURRENT TEMPERATURE.



- **NETWORK STATUS:**

Not connected (  ), connected (  )

- **TF CARD STATUS:**

No TF card inserted (  ), TF card inserted (  ). The TF card is pre-installed in the machine, so it is normally in the inserted state.

- **APP CONNECTION STATUS:**

Not connected (  ), connecting (  ), connected (  )

- **NOZZLE XYZ POSITION, REMAINING PRINT TIME, and ELAPSED PRINT TIME** are also displayed.

The bottom section of the screen is the STATUS BAR.

After startup, the displayed status is as follows:

- When the device is not connected to the network, it shows “READY”.
- When the device is connected to Wi-Fi, it shows the device’s IP ADDRESS.
- During printing, it shows the FILE NAME.

Press the “←” button to enter the MAIN MENU.

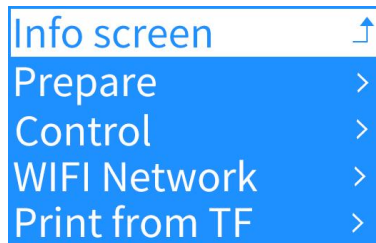

The Main Menu contains FIVE OPTIONS:

Info Screen: Return to the Home Screen.

- Prepare: Maintenance and adjustment functions for the printer.
- Control: Printer function and settings menu.
- WIFI Network: Wi-Fi information, QR codes, and reset options.
- Print From TF: Displays the list of files on the TF card.

### 3.2.Prepare Menu

Press the “V” button to move down and enter the Prepare menu.

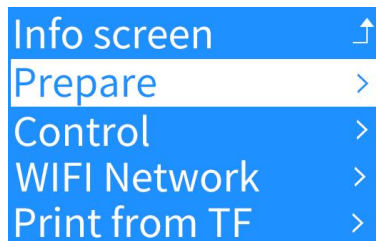

Press the “↵” button lightly. The menu has two pages; use the “^” and “V” buttons to scroll through the options.

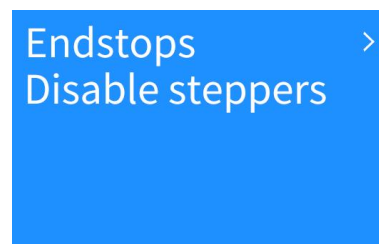
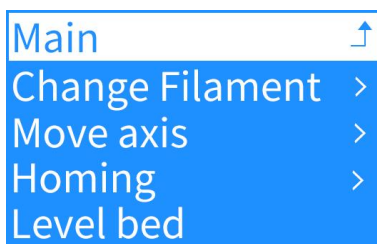

#### 3.2.1.Change Filament

Use to properly unload and load filament. Do not pull filament out directly to avoid clogs.



## 1. Change Filament:

Use the “Change Filament” function and follow the on-screen prompts to help prevent nozzle clogging caused by improper operation. Select filament type to heat nozzle.



Select the corresponding filament type. The nozzle will heat to 240 °C for PLA, 240 °C for TPU, and 245 °C for PETG.

After the nozzle reaches the set temperature, the machine will automatically unload the filament.

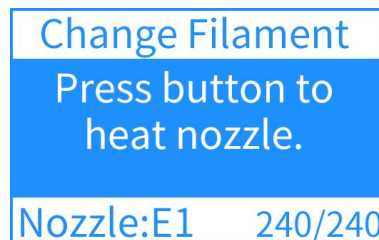
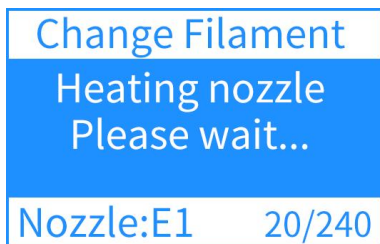

The filament will be automatically loaded through the extruder inlet. After advancing approximately 30 cm into the nozzle, it will continue extruding about 15 cm to ensure smooth feeding.

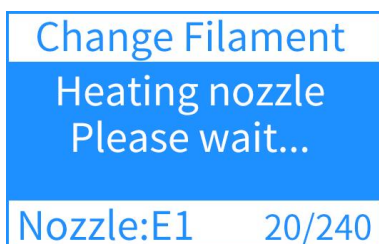

## 2. Load Filament:

The nozzle will heat automatically and the filament will be loaded. Press the button to enter the automatic filament loading interface.

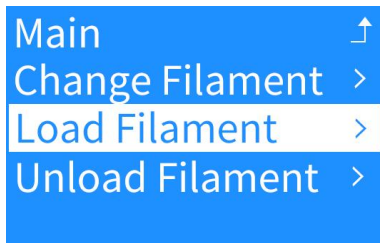

The nozzle will heat to the set temperature, and then the extruder motor will start to push filament through the nozzle.

During heating or extrusion, press the “Confirm” button to exit the current operation.

### 3. Unload Filament:

The nozzle will heat automatically and the filament will be unloaded.

Press the button to enter the sub-menu.

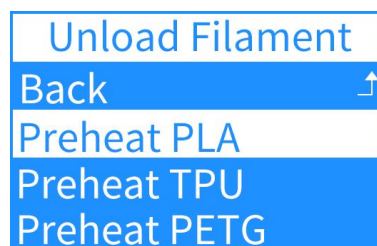

The nozzle will heat to the set temperature, and then the extruder motor will start to unload the filament.

During heating or unloading, press the “Confirm” button to exit the current operation.

### 3.2.2. Move Axis

Jog operation allows you to control the movement of each axis motor, facilitating device adjustment and troubleshooting.

Press the “↵” button to enter the sub-menu.

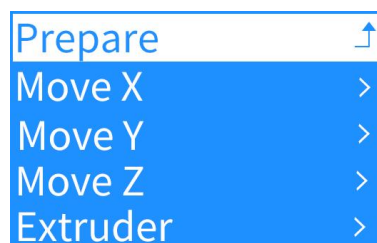
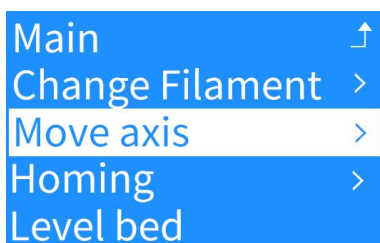

Press “Move axis,” then press the adjustment buttons for X, Y, Z, or the extruder to control the movement of each motor individually.

The left/right adjustment increments for the X, Y, and Z axes are 10 mm, 1 mm, and 0.1 mm, respectively.

The extruder motor increments, from large to small, are 10 mm, 1 mm, and 0.1 mm.

In each axis’s adjustment interface, press the “^” and “v” buttons to move the printer axis motor

in both directions.

Control the X-axis motor movement:

|          |   |
|----------|---|
| Prepare  | ↑ |
| Move X   | > |
| Move Y   | > |
| Move Z   | > |
| Extruder | > |

|            |   |
|------------|---|
| Move X     |   |
| Move axis  | ↑ |
| Move 10mm  | > |
| Move 1mm   | > |
| Move 0.1mm | > |

Move X: +102.0

Control the Y-axis motor movement:

|          |   |
|----------|---|
| Prepare  | ↑ |
| Move X   | > |
| Move Y   | > |
| Move Z   | > |
| Extruder | > |

|            |   |
|------------|---|
| Move Y     |   |
| Move axis  | ↑ |
| Move 10mm  | > |
| Move 1mm   | > |
| Move 0.1mm | > |

Move Y: +50.0

Control the Z-axis motor movement:

|          |   |
|----------|---|
| Prepare  | ↑ |
| Move X   | > |
| Move Y   | > |
| Move Z   | > |
| Extruder | > |

|            |   |
|------------|---|
| Move Z     |   |
| Move axis  | ↑ |
| Move 10mm  | > |
| Move 1mm   | > |
| Move 0.1mm | > |

Move Z: +30.0

Control the extruder motor movement:

|          |   |
|----------|---|
| Prepare  | ↑ |
| Move X   | > |
| Move Y   | > |
| Move Z   | > |
| Extruder | > |

|            |   |
|------------|---|
| Extruder   |   |
| Move axis  | ↑ |
| Move 10mm  | > |
| Move 1mm   | > |
| Move 0.1mm | > |

Extruder: +990.5

**CAUTION:**

RANGE IS 0-100MM PER AXIS. PERFORM "AUTO HOME" FIRST FOR CORRECT NOZZLE COORDINATES. WITHOUT HOMING, CURRENT POSITION BECOMES ORIGIN, LIMITING JOG RANGE.

AXIS MOVEMENT LIMITED BY ENDSTOPS. BROKEN OR MISWIRED ENDSTOPS MAY CAUSE MOTOR TO NOT STOP OR MOVE.

EXTRUDER HAS THERMAL PROTECTION, ONLY MOVES WHEN NOZZLE IS >170°C.

### 3.2.3.Homing

Press “Home.” The X, Y, and Z axes will move, and the printer’s nozzle and platform will automatically return to the origin. Movement will stop once the limit switches in all three directions are triggered. This function can be used for troubleshooting. If a motor or limit switch fails, an error message will be displayed.

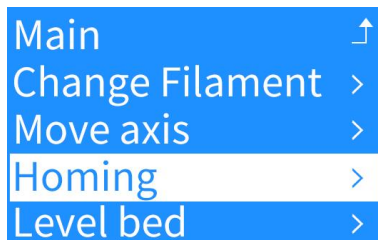

### 3.2.4.Level Bed

Press “Level bed”. The limit switch will detect the platform and record data from nine points. During printing, the nozzle will automatically compensate for any tilt or warp of the platform, ensuring that the build plate remains parallel to the nozzle throughout the printing process.



### 3.2.5.Endstops

Press “Endstops” to display the status of the Z endstop switch and the proximity sensor. By moving the nozzle or platform to trigger a limit switch, you can observe changes in the status of Z endstop switch and the proximity sensor—either ON or OFF. This function can be used for troubleshooting Z endstop and proximity sensor. If a switch is faulty, its status will not change.

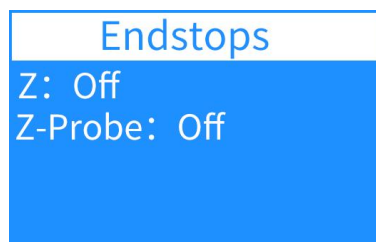
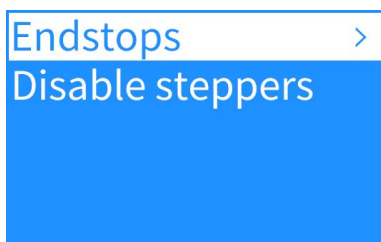

### 3.2.6.Disable Steppers

Releases stepper motor locking, allowing manual nozzle and platform movement.

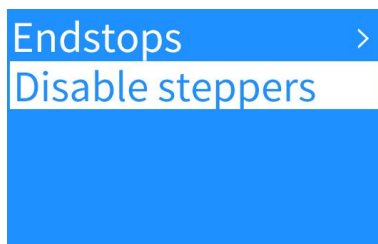

### 3.3.Control Menu

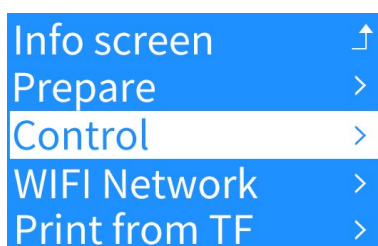

Press the “↵” button lightly. The menu has three pages; use the “^” and “v” buttons to scroll through the options.

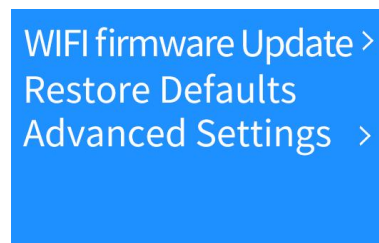
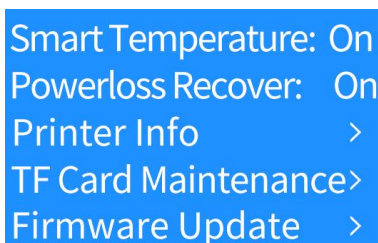
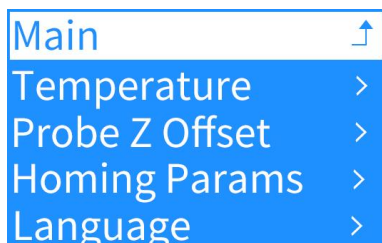

#### 3.3.1.Temperature

Manually set the nozzle temperature. Press “Temperature” to enter the page.

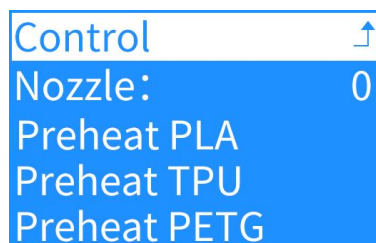
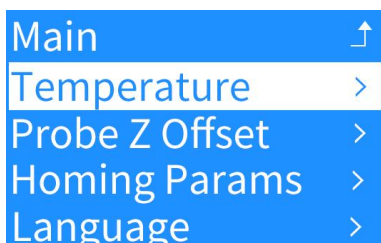

Select Preheat PLA/TPU/PETG: the system will automatically heat the nozzle to 240 °C for PLA, 240 °C for TPU, and 245 °C for PETG.

### 3.3.2. Probe Z Offset

After the auto-leveling process is completed, check the gap between the nozzle and the build plate. If the gap is too small, the nozzle may scratch the build plate surface or cause clogging. If the gap is too large, the printed model may not adhere properly to the build plate, which can lead to detachment and print failure.

We recommend recalibrating the Z-offset before the first print, or after replacing the nozzle or the proximity switch.

Press the “Probe Z Offset” button to enter the adjustment page.

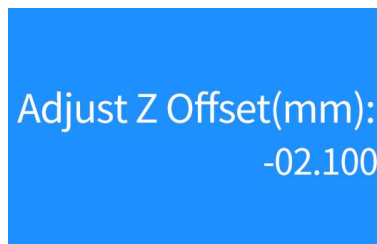
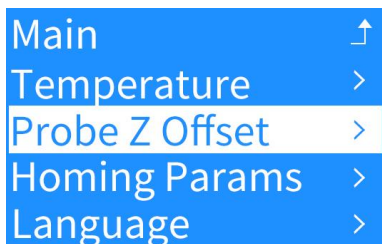

Use the “^” and “v” buttons to adjust the nozzle height up or down.

Press the “↵” button to confirm and save the settings.

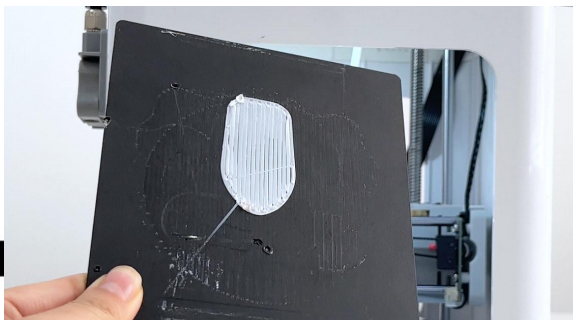
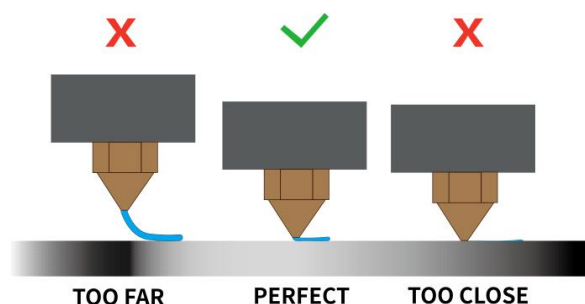

### 3.3.3. Homing Params

Adjust the limit detection sensitivity of the device during the homing process. Higher sensitivity results in faster response but may cause slight positioning deviations, while lower sensitivity provides more stable positioning at the cost of slightly slower homing. Adjust as needed based on the device’s operating condition to achieve optimal positioning accuracy and stability.

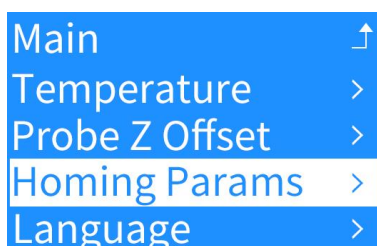

### 3.3.4.Language

Use the “^” and “v” buttons to select from ten languages: English, Chinese, French, German, Spanish, Italian, Japanese, Portuguese, Dutch, and Turkish.

Press the “↵” button to confirm and save your selection.

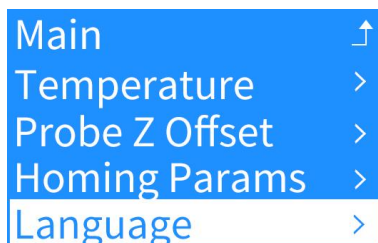

### 3.3.5.Smart Temperature

Press the button to switch OFF/ON .

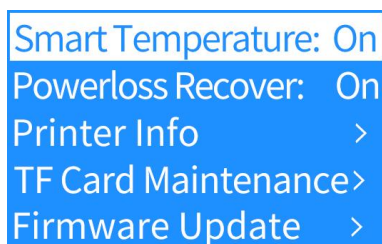

The smart temperature feature is turned on by default. The mainboard can monitor the ambient temperature and increase the temperature of the nozzle and platform according to the ambient temperature.

### 3.3.6.Powerloss Recover: Off

Press the “↵” button to toggle this function ON/OFF.

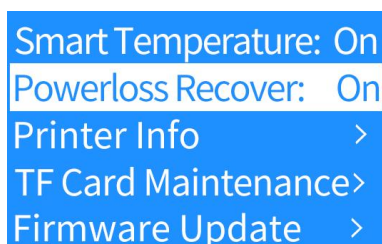

This function is ENABLED BY DEFAULT. Press the “↵” button to disable it.

If a power failure occurs during printing, the printer will save the current print progress.

Upon the next startup, the printer will ask the user whether to continue the print.

IMPORTANT:

PROGRESS SAVED TO ".BIN" FILE ON TF CARD EVERY 10S, OVERWRITING PREVIOUS DATA. ON RESTART AFTER SUDDEN POWER LOSS, CHECKS FOR ".BIN" FILE AND PROMPTS "CONTINUE PRINTING, STOP PRINTING". CONTINUING READS SAVED PROGRESS, STOPPING DELETES ".BIN" FILE.

SINCE SAVING ONLY EVERY 10S, RECOVERY MAY FAIL DUE TO TIME INTERVAL.

### 3.3.7.Printer Info

Press "Printer Info" to view the device firmware version.

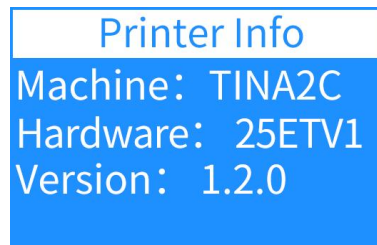
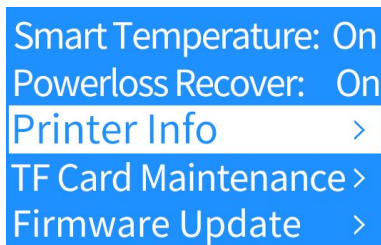

### 3.3.8.TF Card Maintenance

This function is used to resolve occasional issues with the TF card.If such problems occur, formatting the TF card can help fix them.After pressing this function, the system will automatically format the TF card, which can eliminate most errors.

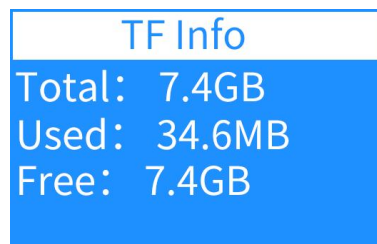
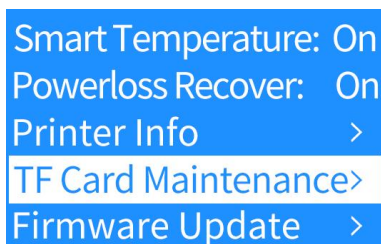

Press "TF Info" to view the TF card capacity. If the capacity is displayed correctly, the TF card is functioning properly.

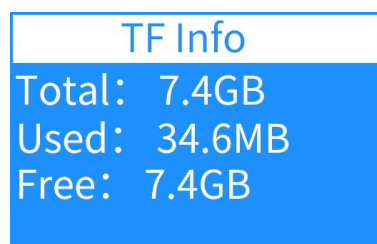
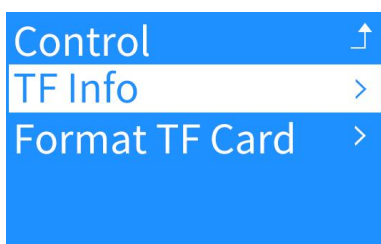

If the "TF Info" cannot be displayed correctly, use the "Format TF Card" function to repair it.

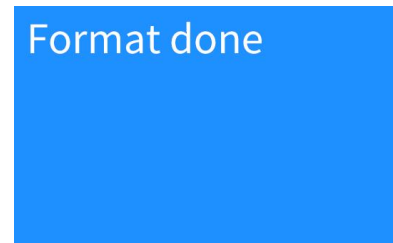
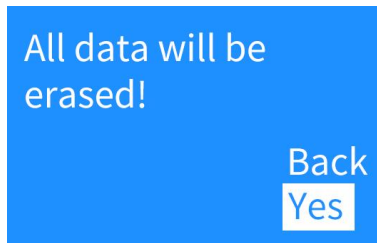
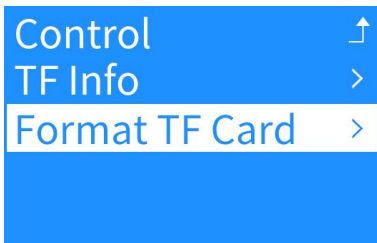

### 3.3.9.Firmware Update

#### PREPARING FOR FIRMWARE UPDATE:

Before updating the firmware, prepare ONE OF THE FOLLOWING DEVICES:

- TF card reader
- Type-C data cable

#### STEPS:

##### 1. CONNECT THE DEVICE

- Remove the TF card from the printer. Insert it into a card reader, then connect the card reader to your computer.
- If using a Type-C data cable, connect the printer directly to the computer. The printer will function as a card reader in this mode.

##### 2. COPY THE FIRMWARE FILE

Copy ".wfx" firmware file to TF card root. Decompress first if needed. Rename to "flash.wfx".

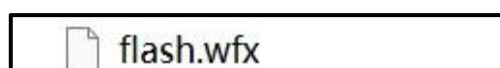

3. INSERT THE TF CARD INTO THE PRINTER, THEN PRESS "FIRMWARE UPDATE" ON THE CONTROL PANEL.

4. THE PRINTER WILL AUTOMATICALLY DETECT THE LATEST FIRMWARE ON THE CARD AND START THE UPGRADE.

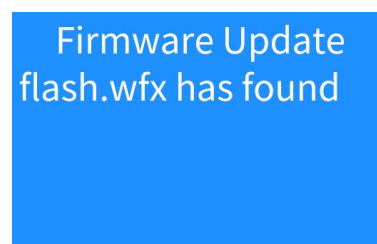
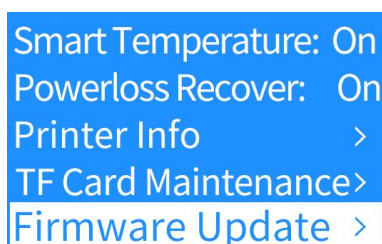

### 3.3.10.WIFI Firmware Update

Before updating the firmware, prepare ONE OF THE FOLLOWING DEVICES:

- TF card reader
- Type-C data cable

#### STEPS:

##### 1. CONNECT THE DEVICE

- Remove the TF card from the printer. Insert it into a card reader, then connect the card reader to your computer.
- If using a Type-C data cable, connect the printer directly to the computer. The printer will function as a card reader in this mode.

##### 2. COPY THE FIRMWARE FILE

Copy ".efx" firmware file to TF card root. Decompress first if needed. Rename to "wifi.efx".



3. INSERT THE TF CARD INTO THE PRINTER, THEN PRESS “WIFI FIRMWARE UPDATE” ON THE CONTROL PANEL.

4. THE PRINTER WILL AUTOMATICALLY DETECT THE LATEST FIRMWARE ON THE CARD AND START THE UPGRADE.

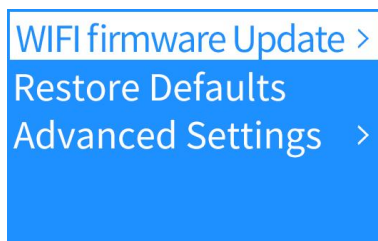

### 3.3.11.Restore Defaults

Resets all parameters to factory defaults.

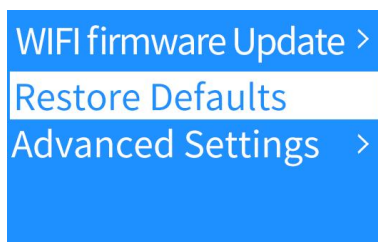

### 3.3.12.Advance Settings

Modify advanced parameters. Beginners use defaults.

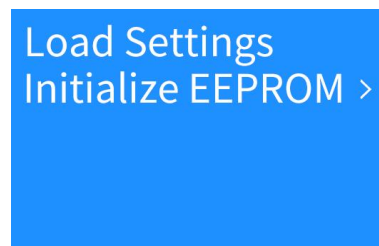
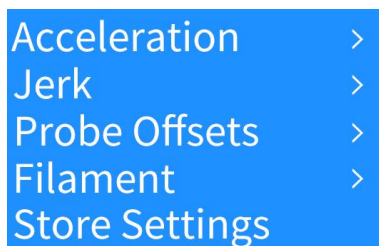
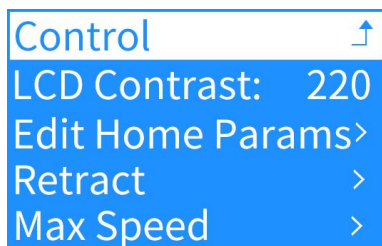
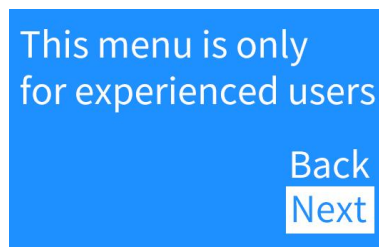
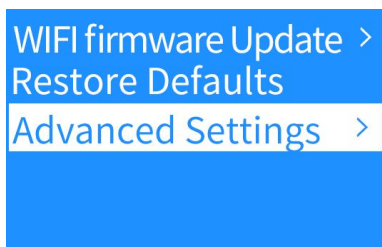

LCD Contrast: Adjust screen clarity

Retract: Auto-retract, amount, speed, etc.

Edit Home Params: Adjust the limit detection sensitivity of the device during the homing process. Higher sensitivity results in faster response but may cause slight positioning deviations, while lower sensitivity provides more stable positioning at the cost of slightly slower homing. Adjust as needed based on the device's operating condition to achieve optimal positioning accuracy and stability. Max Speed (mm/s): Same as in slicer

Acceleration: Increase print speed

Jerk: Increase acceleration ramp time and corner/jitter speed

Probe Offsets: Set X/Y/Z offsets

Filament: Set extruder compensation

Store Settings: Save changes

Load Settings: Apply saved changes

Initialize EEPROM: Reset to defaults

### 3.4.WIFI Network

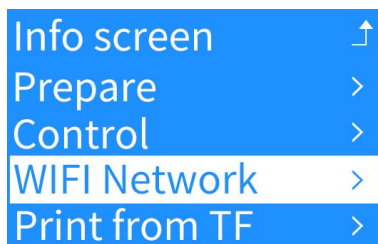

The TINA2C offers two network connection modes: LAN MODE and APP MODE.

#### LAN MODE:

When the printer and the computer are connected to the same local network, the Wiibuilder software on the computer can connect to the printer for remote control or for sending print files.

LAN Mode requires the printer to be successfully connected to a Wi-Fi network.

#### APP MODE:

Using the mobile app, users can remotely control the printer or download print models.

APP Mode allows remote operation from any location.

To use APP Mode, the printer must be successfully connected to a Wi-Fi hotspot and bound to the user's APP account.

Each printer can be bound to ONLY ONE APP account.

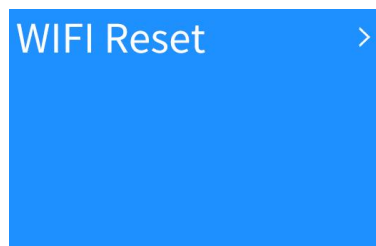
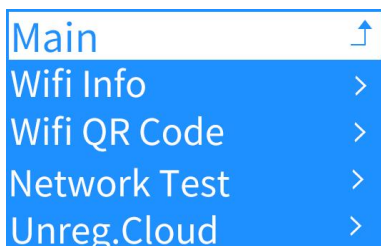

The network function of TINA2C has two connection modes, local mode, and remote mode.

Local mode: In the same local area network, Wiibuilder or Cura on the computer can connect to the 3D printer, and perform remote control or send print files. To use local mode, the 3D printer should be connected to the local WIFI network.

Remote mode: Use our APP, PoloPrint Cloud, remotely control the 3D printer or download the print model. With the remote mode, you can remotely control the 3D printer from any location. To use remote mode, the 3D printer should be connected to the WIFI network and registered with the APP. Notice, a 3D printer can only be registered by one APP account.

#### 3.4.1.WIFI Info

Press "WIFI Info" to open the WIFI info screen. It will show the WIFI firmware version, the serial, IP address, AP name, and the connection status of the cloud server. Only after configuring the network and registering in the APP will the 3D printer connect to the cloud server.

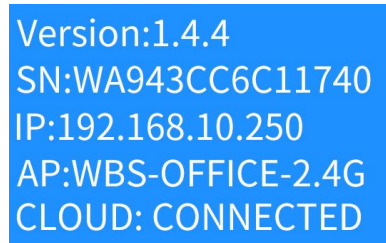
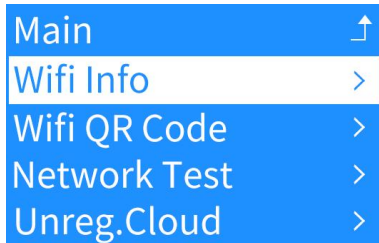

### 3.4.2.WIFI QR Code

Press "WIFI QR Code" to show the QR code generated by the device serial. Used for App scanning networking and cloud access.

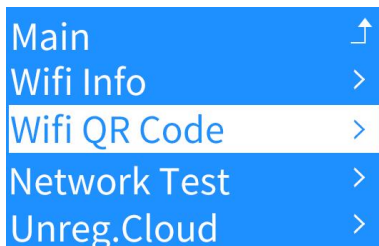

### 3.4.3.Network Test

Press "Network Test" to start testing the current network connection and response time.

If the printer encounters network or app-related issues, use this function to check whether the network is properly connected or if the connection speed is too slow.

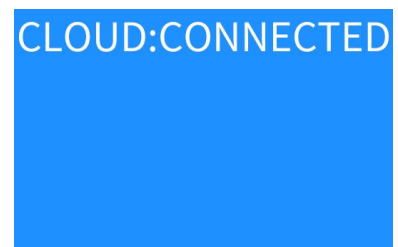
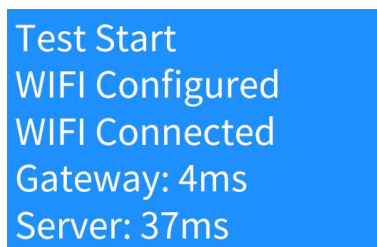
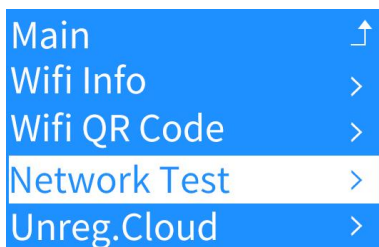

### 3.4.4.Unreg. Cloud

Press "Unreg. Cloud" to view the instructions for deregistering from the cloud platform.

Please follow the tutorial to complete the operation in the app.

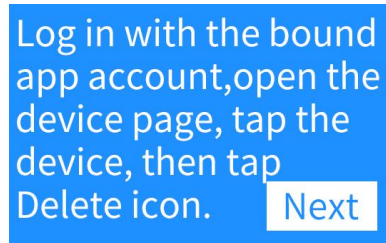
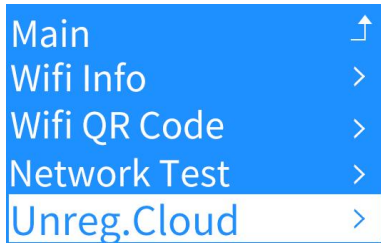

### 3.4.5.WIFI Reset

Each time the TINA2C is powered on, it automatically reconnects to the last successfully used Wi-Fi network. If you need to connect the TINA2C to a new Wi-Fi network, you must perform the Reset Wi-Fi Settings function to clear the previously saved network information.

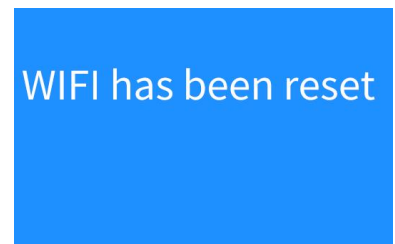
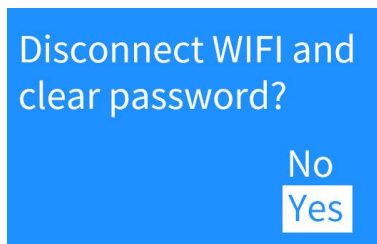

### 3.5.Print from TF

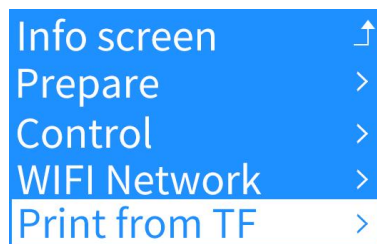

Shows ".gco" or ".gcode" print files on TF card.

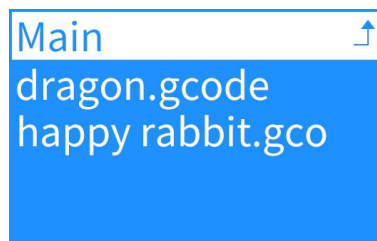

Select file and press knob for print info. "Print" starts printing.

To prevent damage, checks machine model in file. Blocks print if model mismatched or missing. Use Wiibuilder or custom Cura version and select correct model when slicing.

NOTE: FILE NAMES ≤20 CHARACTERS TO AVOID DISPLAY ISSUES.

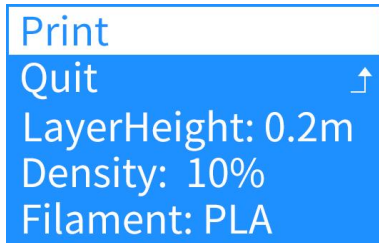

During print, press knob for print settings menu.

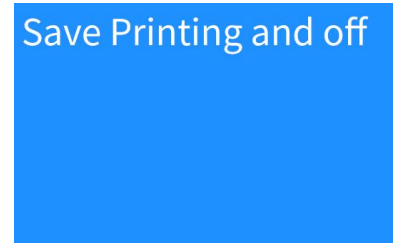
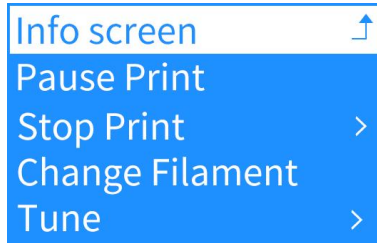
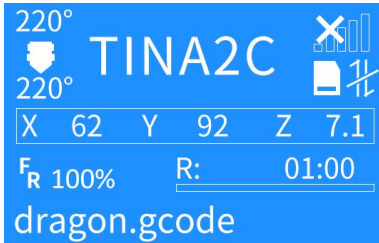

### 3.5.1. Pause Print

Pauses print and moves nozzle to pause position. Can resume from pause.

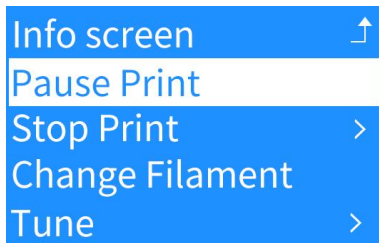

### 3.5.2. Stop Print

Cancels current print and returns to Info Screen.

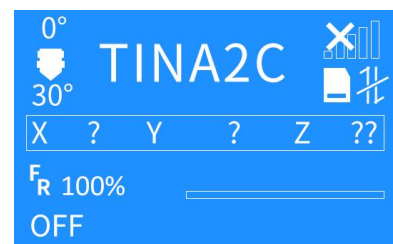
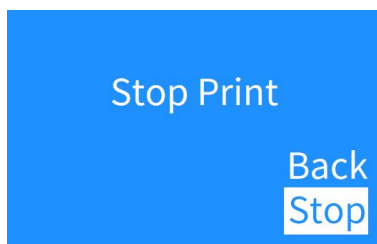
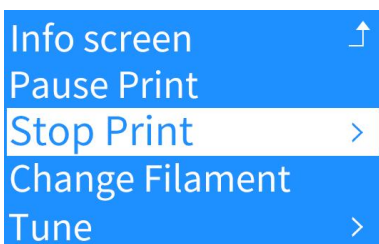

IMPORTANT:

REMOVE PRINTED MODEL FROM PLATFORM AFTER STOPPING.

### 3.5.3. Change Filament

Same steps as Change Filament in Prepare menu:

Heat to set temp. Auto-unload at temp.

|                 |   |
|-----------------|---|
| Info screen     | ↑ |
| Pause Print     |   |
| Stop Print      | > |
| Change Filament |   |
| Tune            | > |

|                          |
|--------------------------|
| Change Filament          |
| Wait for filament unload |
| Nozzle:E1 240/240        |

|   |
|---|
| Change Filament                                 |
| Insert filament and press button to continue... |
| Nozzle:E1 240/240                               |

When the device emits a “BEEP” sound, insert the new filament and press the “↵” button.

The system will automatically load the filament after heating to the working temperature. Once the filament is fully extruded, the device will automatically resume printing.

|                                      |
|--------------------------------------|
| Change Filament                      |
| Wait for filament load click to skip |
| Nozzle:E1 240/240                    |

|                                       |
|---------------------------------------|
| Change Filament                       |
| Wait for filament purge click to skip |
| Nozzle:E1 240/240                     |

### 3.5.4.Tune

“Tune” to modify the print speed, nozzle temperature, extruder speed, and Z-offset.

|                 |   |
|-----------------|---|
| Info screen     | ↑ |
| Pause Print     | > |
| Stop Print      | > |
| Change Filament | > |
| Tune            | > |

|                |     |
|----------------|-----|
| Main           | ↑   |
| Speed:         | 100 |
| Nozzle:        | 200 |
| Flow:          | 100 |
| Probe Z Offset | >   |

1.Speed: Select “Speed” and use the “^” and “v” buttons to adjust to the desired percentage.

Press the button to confirm.

|                |     |
|----------------|-----|
| Main           | ↑   |
| Speed:         | 100 |
| Nozzle:        | 200 |
| Flow:          | 100 |
| Probe Z Offset | >   |

|        |     |
|--------|-----|
| Speed: | 100 |
|--------|-----|

2.Nozzle temp: Select “Nozzle” and use the “^” and “v” buttons to adjust to the desired nozzle temperature. Press the button to confirm.

|                |     |
|----------------|-----|
| Main           | ↕   |
| Speed:         | 100 |
| Nozzle:        | 200 |
| Flow:          | 100 |
| Probe Z Offset | >   |

Nozzle: 200

3.Probe Z Offset:Select “Probe Z Offset” and use the “^” and “v” buttons to fine-tune the gap between the nozzle and the build plate. Press the button to confirm.

This function allows you to adjust the Z-axis height in real time during printing to change the nozzle-to-plate gap.At the beginning of a print, if the gap is too small and the nozzle is not extruding properly, increase the Z-offset by 0.2 mm.If the gap is too large and the extruded filament does not adhere well to the build plate, gradually decrease the Z-offset.

|                |     |
|----------------|-----|
| Main           | ↕   |
| Speed:         | 100 |
| Nozzle:        | 200 |
| Flow:          | 100 |
| Probe Z Offset | >   |

Adjust Z Offset(mm):  
-02.100

### 3.5.5.Save Printing and Off

Saves progress, moves to pause position, allows safe power off. Prompts to resume on next power on.

Save Printing and off

Save Printing and Off  
Wait for printing  
stop, then turn off  
the power

dragon.gcode  
Resume Print  
Stop Print

IMPORTANT:

"PAUSE PRINT" AND "SAVE PRINT" TRIGGER HOMING. MECHANICAL ENDSTOP TOLERANCES CAUSE SLIGHT DEVIATION ON EACH HOME, POTENTIAL SEAM/SHIFT AT RESUME POINT.

PRINT MODELS IN ONE SESSION WHEN POSSIBLE TO AVOID THIS.

# 4.COMMON MENU OPERATIONS

## 4.1.Print from TF Card

- Open Main Menu, select "Print From TF".
- Turn knob to select file, press knob to start print.

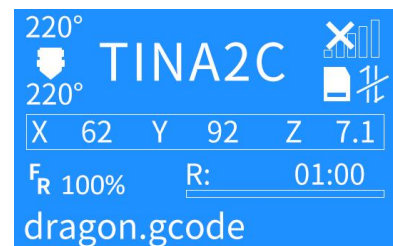
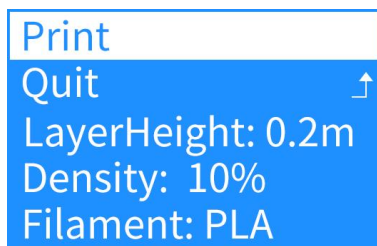
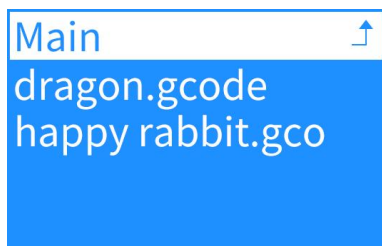
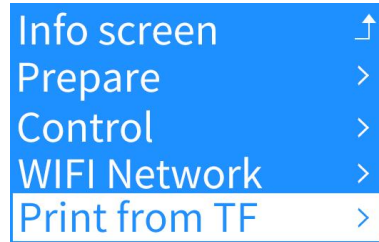
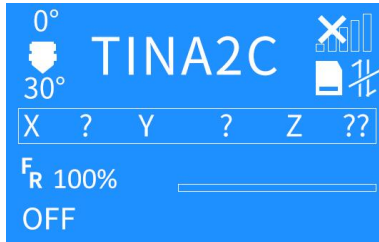

## 4.2.Print Multi-Color Models / Change Filament During Print

Same steps as Change Filament in Prepare menu:

Heat to set temp.Auto-unload at temp.

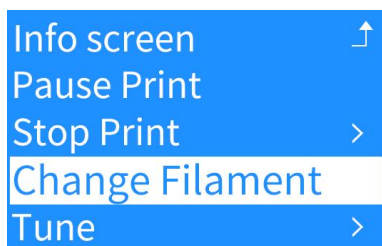

When the device emits a “BEEP” sound, insert the new filament and press the “↵” button.

The system will automatically load the filament after heating to the working temperature. Once the filament is fully extruded, the device will automatically resume printing.

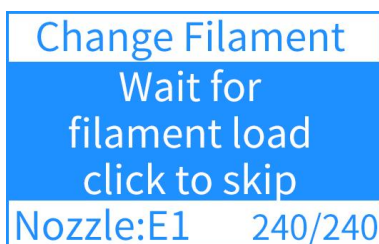

### 4.3. Adjust Temperature During Print

During print, press knob for print settings menu, select Tune > Nozzle to adjust temp:

Turn knob to increase/decrease temp. Press knob to return.

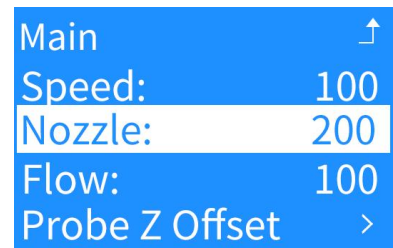
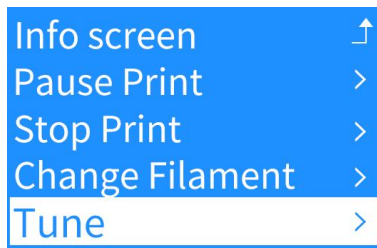
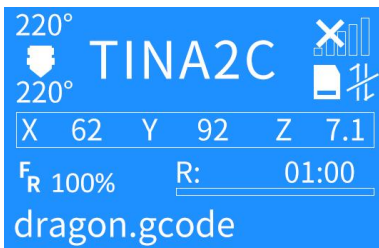

### 4.4. Adjust Z Offset During Print

During print, press knob for print settings menu, select Tune > Probe Z Offset to fine-tune nozzle-platform gap.

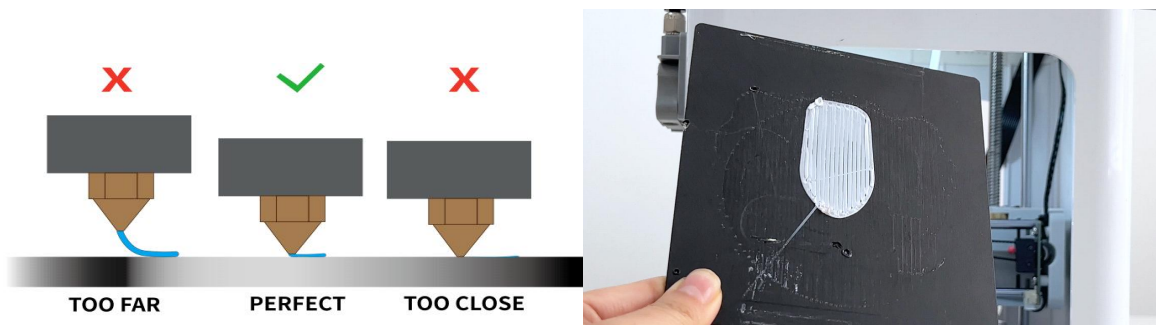
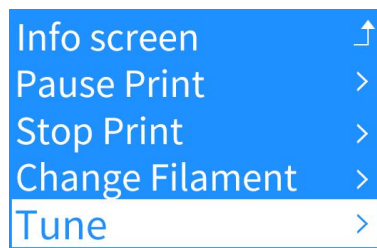
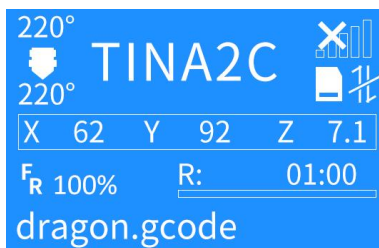

Use the “ ^ ” and “ v ” buttons to fine-tune the nozzle height so that the first-layer extrusion appears smooth and slightly flattened.

If the nozzle is too high, the filament will not adhere to the build plate. If it is too low, the first layer cannot extrude properly and may cause clogging. In addition to adjusting the Z-offset during printing, you can also adjust it in the “Control” menu before printing. After auto-leveling is completed, check the gap between the nozzle and the build plate. If the gap is too small, the nozzle may scratch the build surface or cause clogging. If the gap is too large, the printed model will not adhere well and may detach from the platform, resulting in print failure.

We recommend resetting the Z-offset before the first print, or after replacing the nozzle or the proximity sensor.

# 5.PRINT BY APP

To use the TINA2C with the Poloprint Cloud App, the following two conditions must be met:

- 1.The device is successfully connected to your home WiFi network.
- 2.The device is linked to your App account.

Both of these steps are covered in Step 5 of the App’ s startup guide.

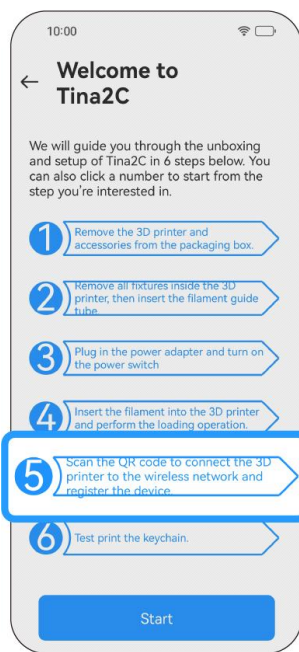

If the user misses this step during the initial setup, they can use the following two functions to reconnect the device to the network and link it to their account.

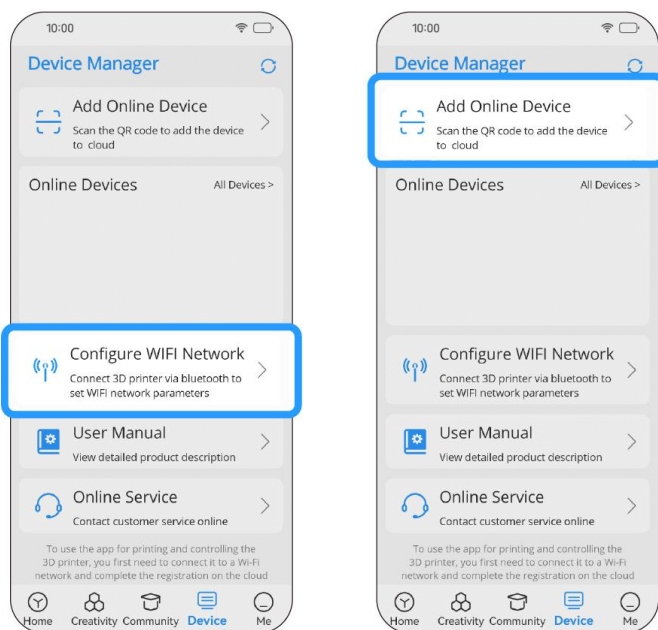

When the homepage displays an IP address, it indicates that the device has successfully connected to the network. The number of Wi-Fi signal bars shown on the screen represents the current signal strength.



When the homepage displays “Connected Successfully,” the slash on the cloud platform icon will disappear, indicating that the device has successfully connected to the cloud platform.



After the device is connected to the network and linked to the account, the App can control the printer. Users can select a model in the App and start printing.

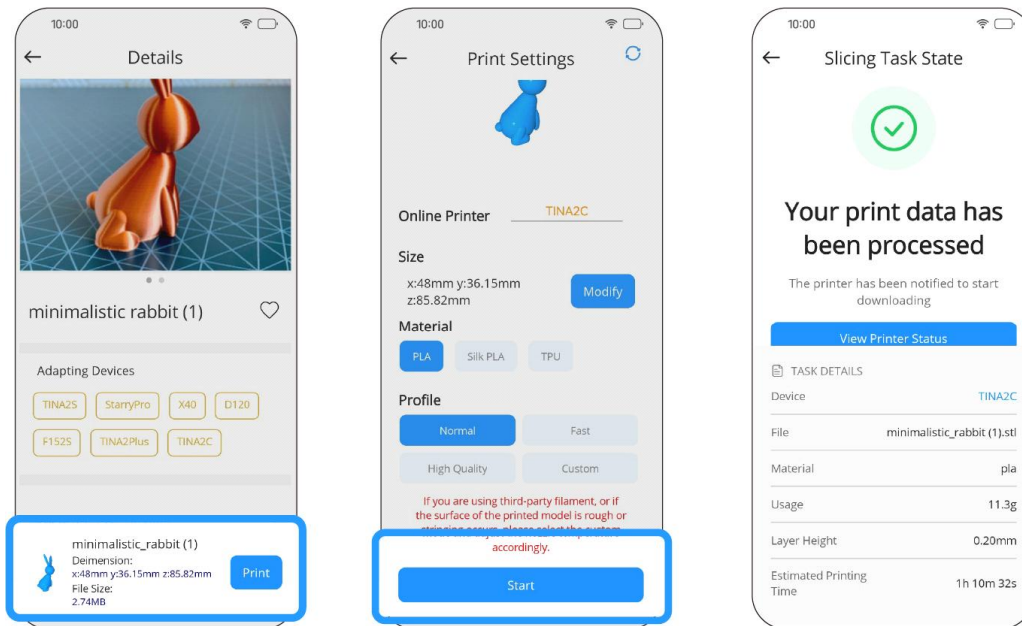

# 6.WIIBUILDER SLICING SOFTWARE

3D models usually STL files, not directly recognized by 3D printers. Models processed in slicing software to generate G-code files for printing.

3D printing process:

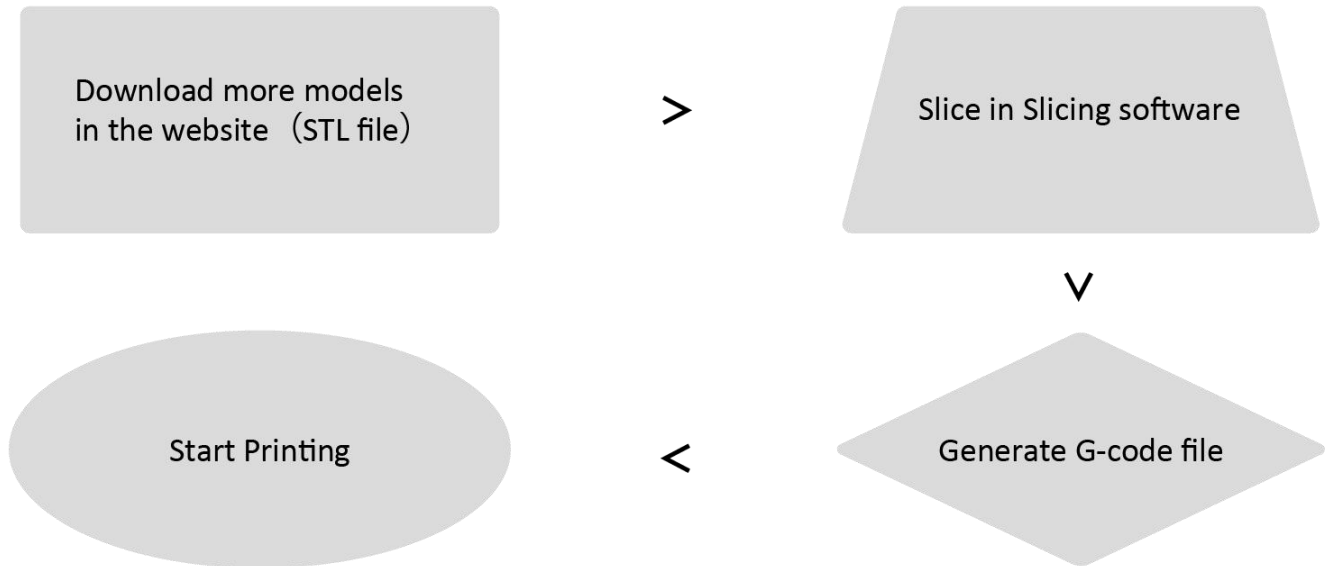

Slicing software installed on computer. Common options: Wiibuilder, Cura. Wiibuilder developed in-house, user-friendly, recommended.

Wiibuilder included on printer's TF card. Use card reader to view TF contents on PC for installation.

System requirements for Wiibuilder:

- CPU: Pentium 1GHz
- RAM: 1GB minimum
- Disk: 1GB+ free space
- Display: 640x480 minimum
- Graphics: 3D acceleration, OpenGL 2.0+
- Color: 256 colors minimum
- OS: Windows 7+ / MacOS 10.13.6+
- Other: .Net Framework 4.5.2+

# 6.1.Installation

## 6.1.1.Installation on Windows

Steps to install Wiibuilder:

Locate and run Wiibuilder.exe on TF card. Click Install > Next > Finish to continue.

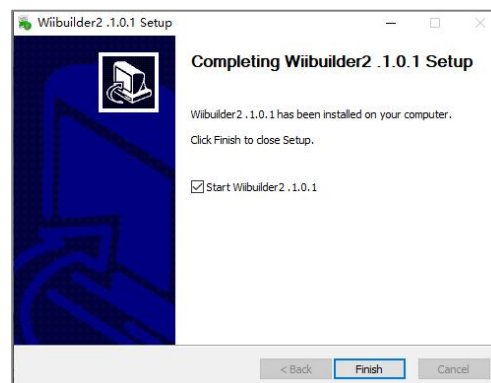
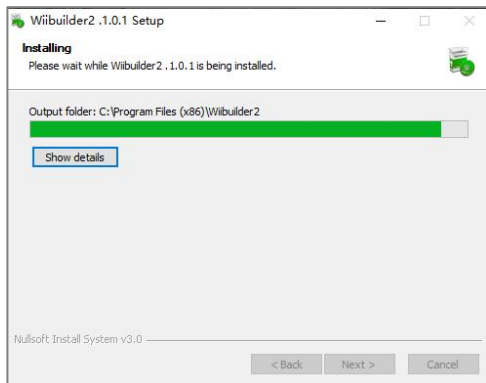
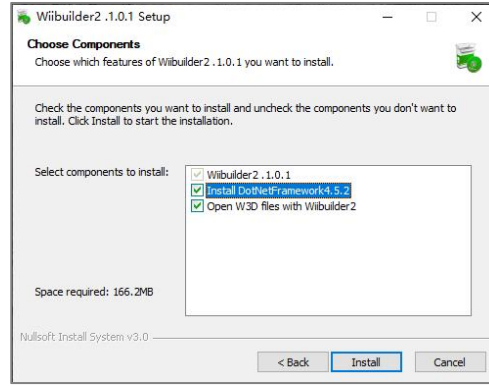
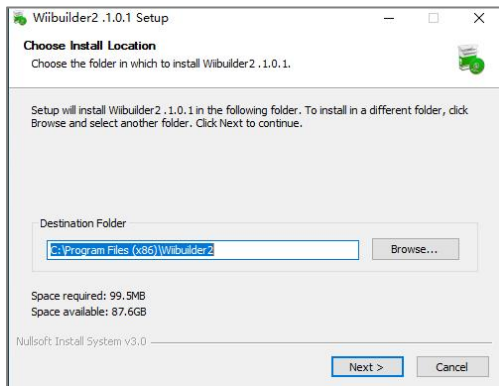

## 6.1.2.Installation on MacOS

OS: MacOS 10.13.6+

Decompress installer. Double-click package, drag Wiibuilder to Applications.

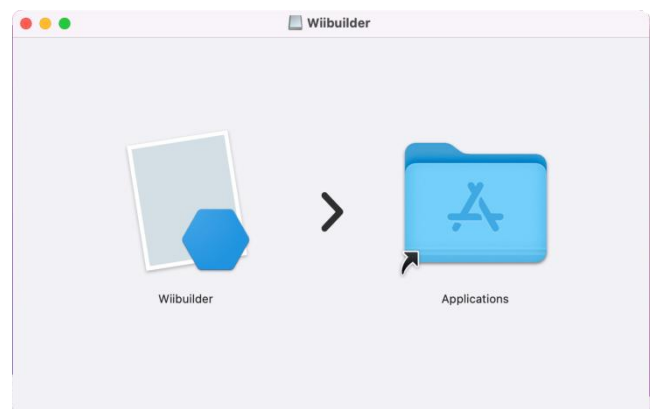

## 6.2.Interface Introduction

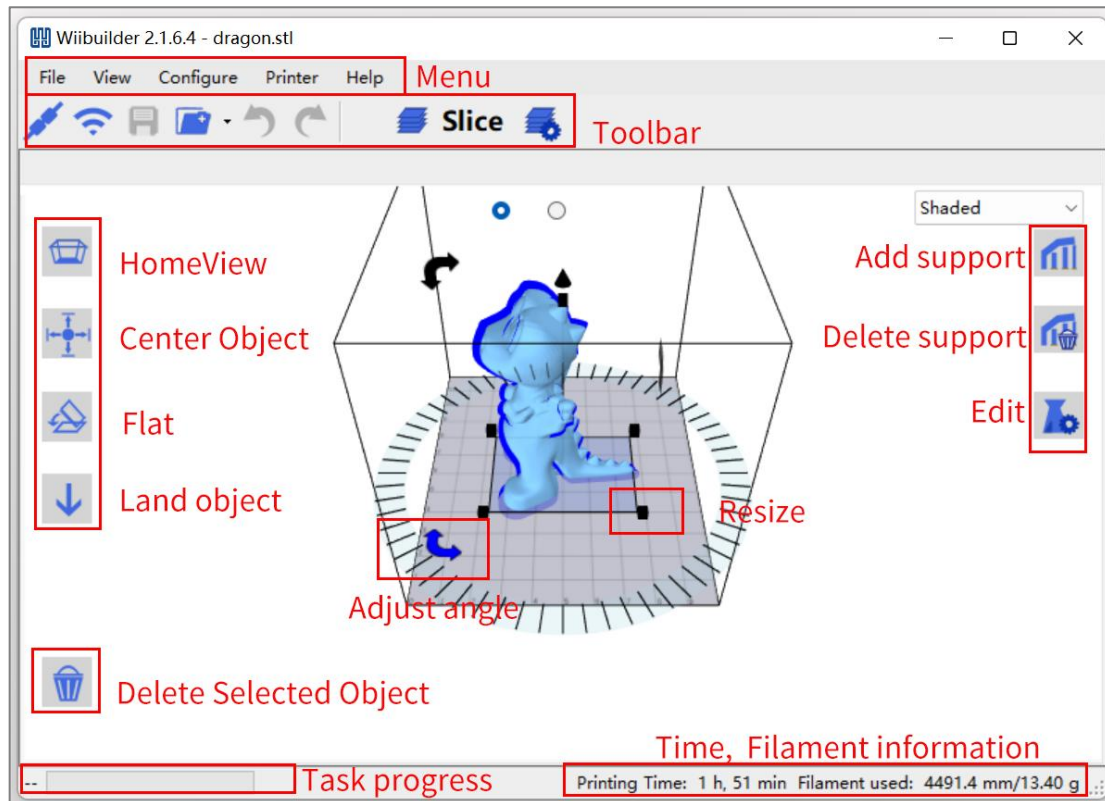

- Menu Bar: Access Wiibuilder menu
- Toolbar: USB/WiFi connect, save Gcode, load model, undo/redo, slice, settings
- Home View: Restore default view angle
- Center Object: Auto-adjust model XY to center on platform
- Flat: Auto-flatten tilted model on platform
- Land Object: Auto-adjust model Z to align bottom with platform
- Delete Selected: Remove current model
- Add/Delete Support: Manually add/remove model supports
- Edit: Open model and Gcode editor

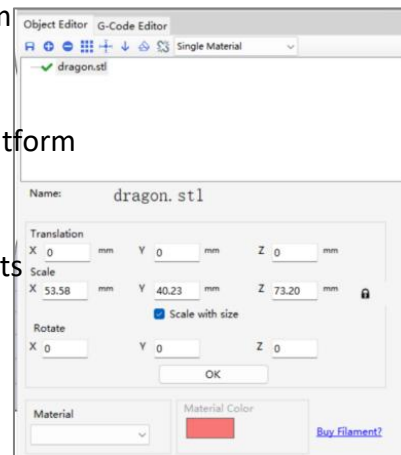

Right-click model for context menu:

- Copy model
- Mirror on X/Y/Z axis
- Delete model
- Export model to STL
- Arrange All Parts: Auto-adjust multi-model position and spacing

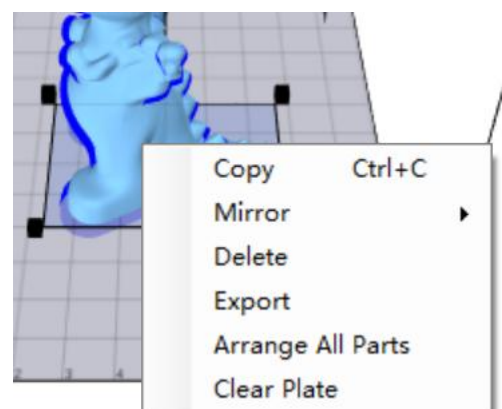

●Clear Plate: Remove all models

Slicing Settings:

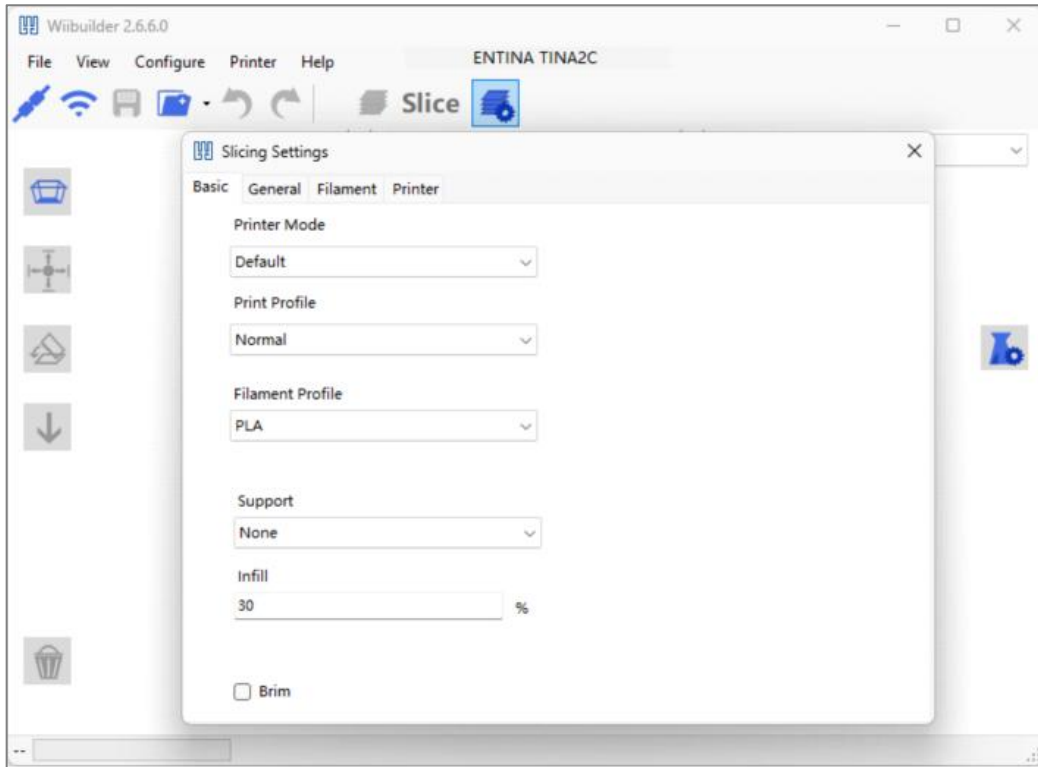

### 6.3.Select Language

Open Wibuiler, click Configure > Language to select.

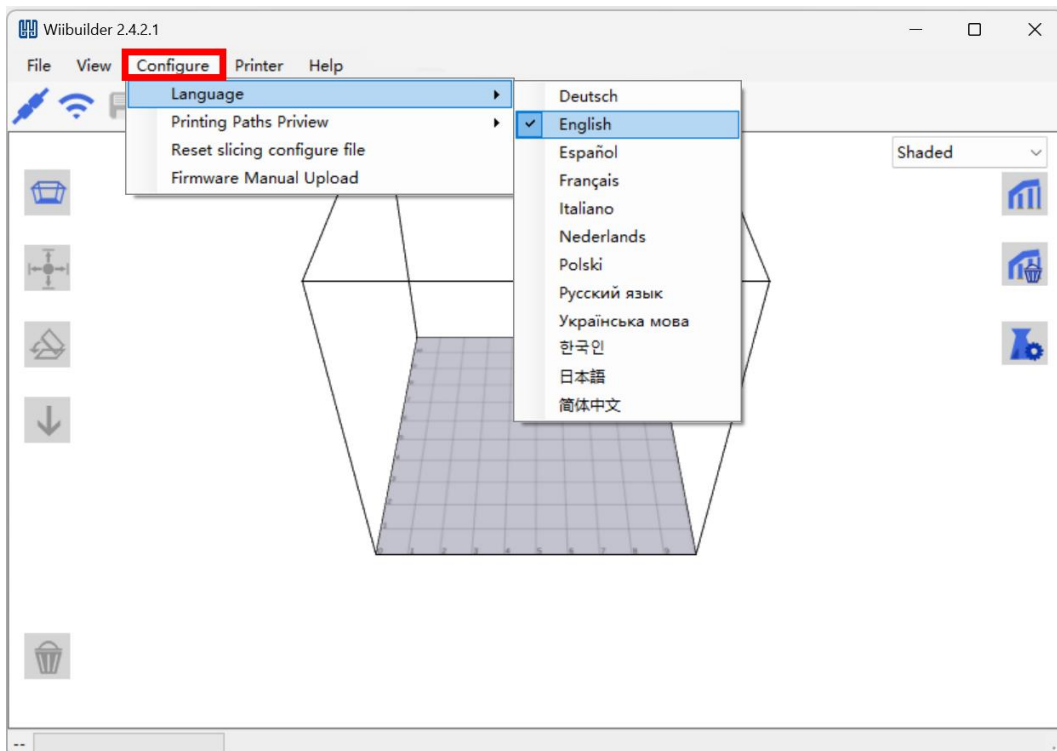

## 6.4. Select Printer

Click Printer to select model.

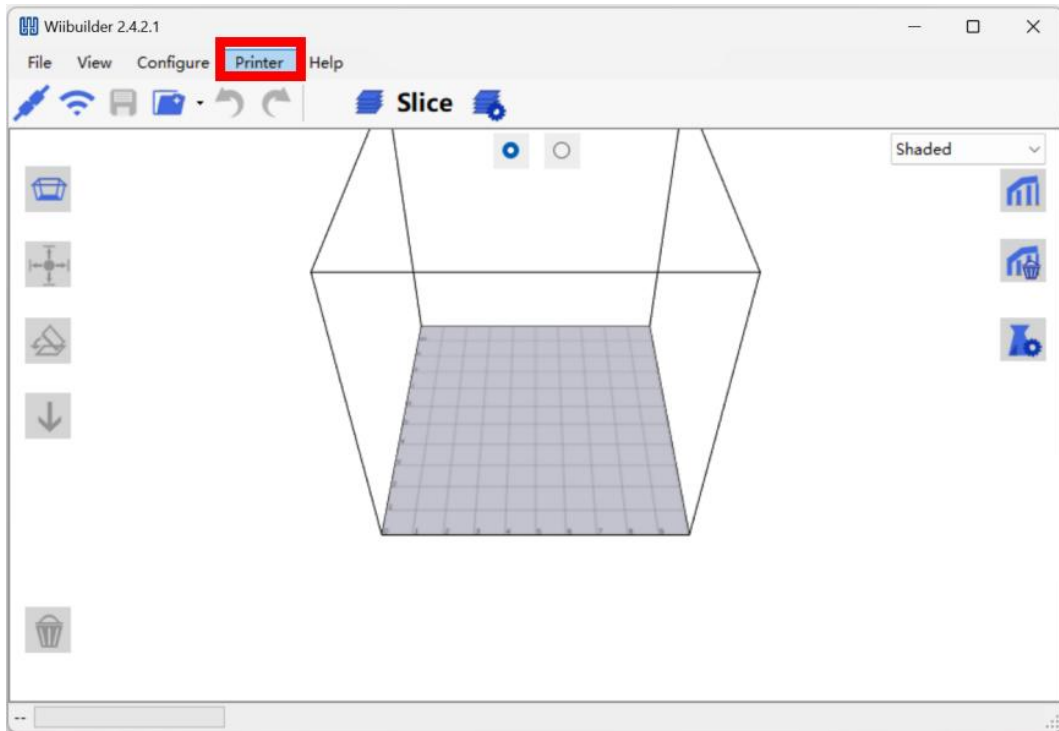

Click Printer and scroll to find "TINA2C".

Note: Do not select "TINA2", "TINA2S", or "TINA2 Plus"; choosing the wrong model will cause the connection to fail.

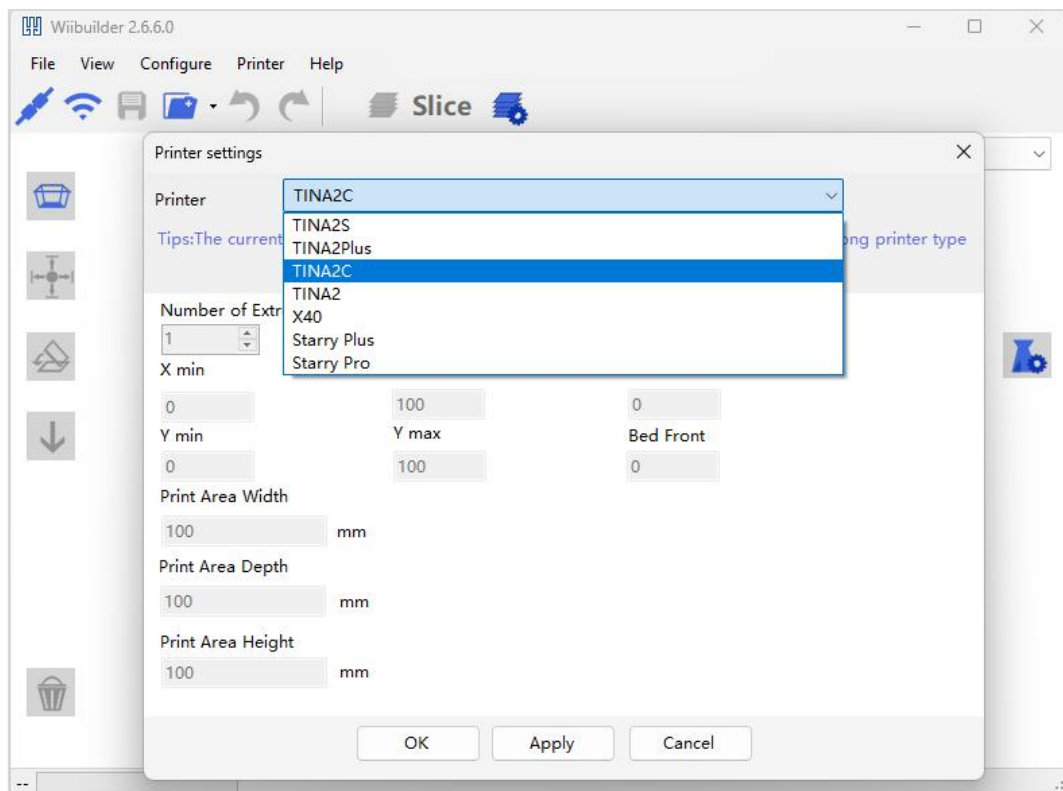

## 6.5.Add Model

Open Wiibuilder, click File to load model or drag model in.

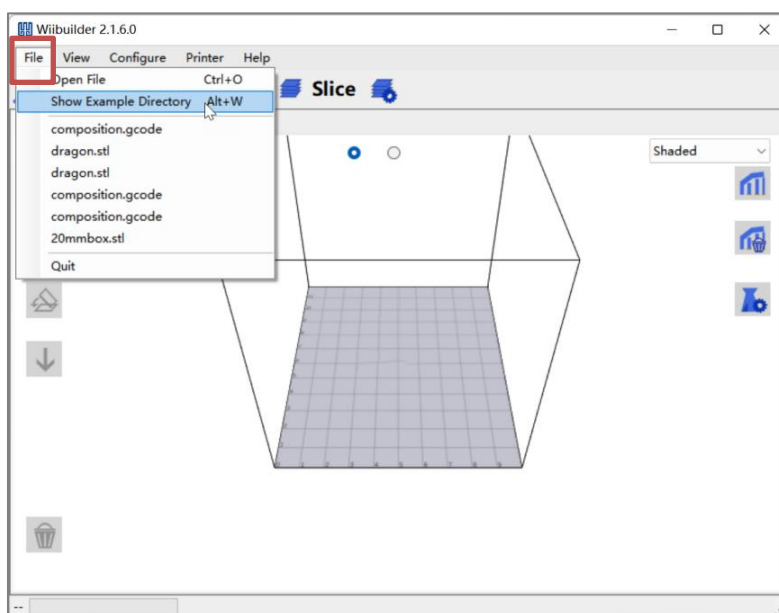

Five sample models in "Show Example Directory" for test printing.

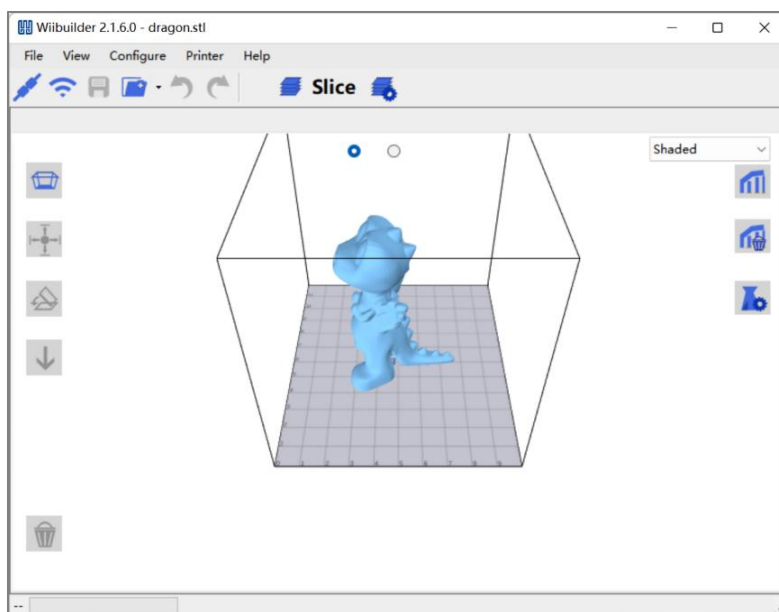

## 6.6.Adjust Model

Click model to adjust size, angle, position.

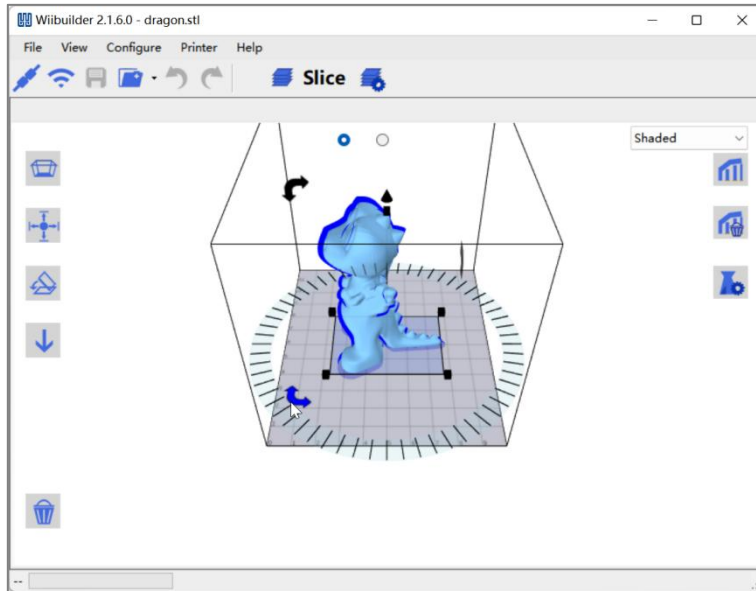

Model should be centered and properly placed on platform. Click Center Object, Flat, Land Object. If floating, print fails.

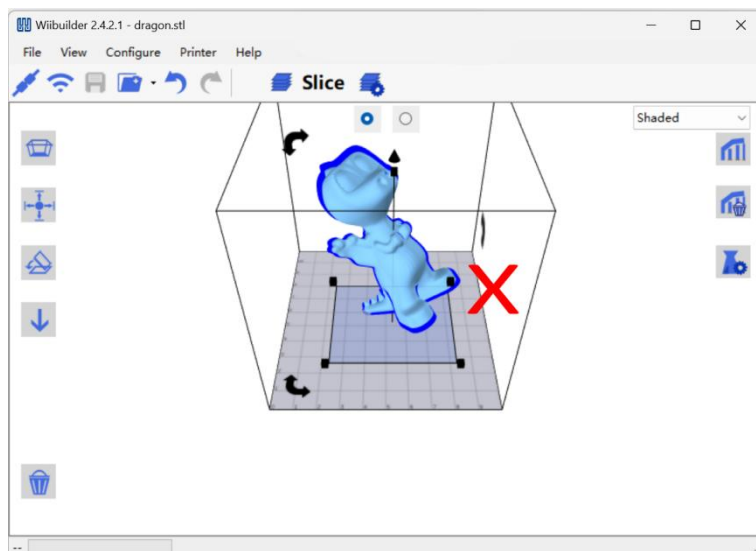
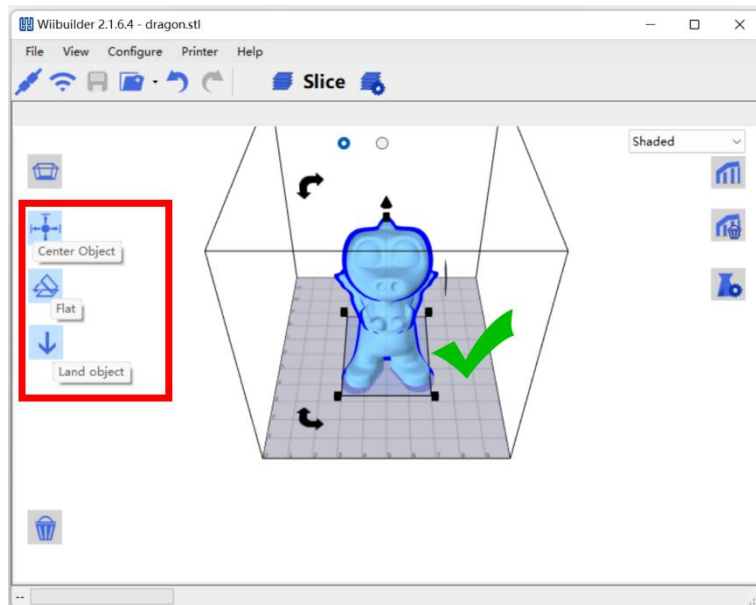

## 6.7. Basic Parameter Settings

Beginners use defaults without adjustment.

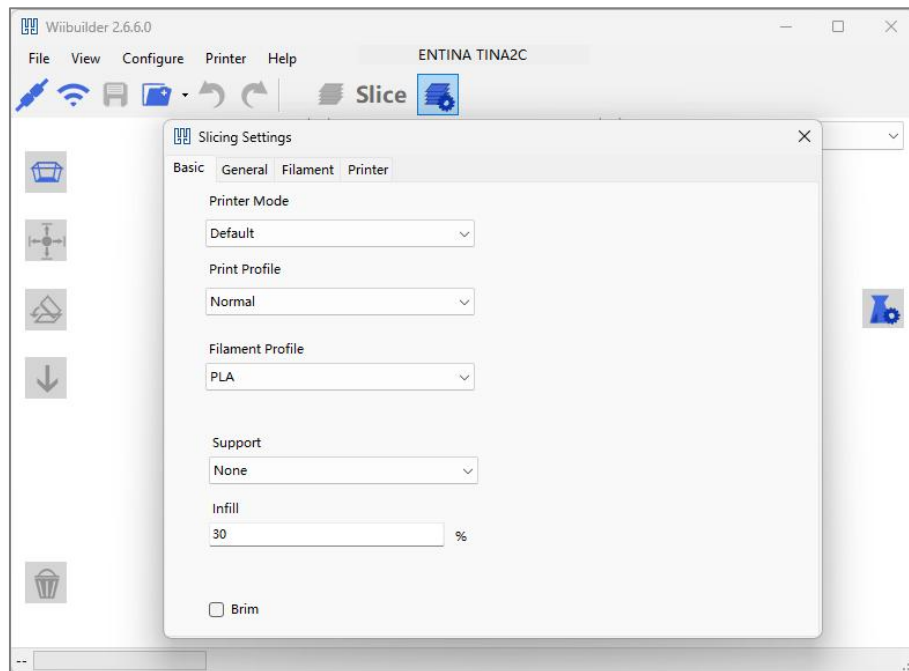

After setting parameters, click Slice to convert file.

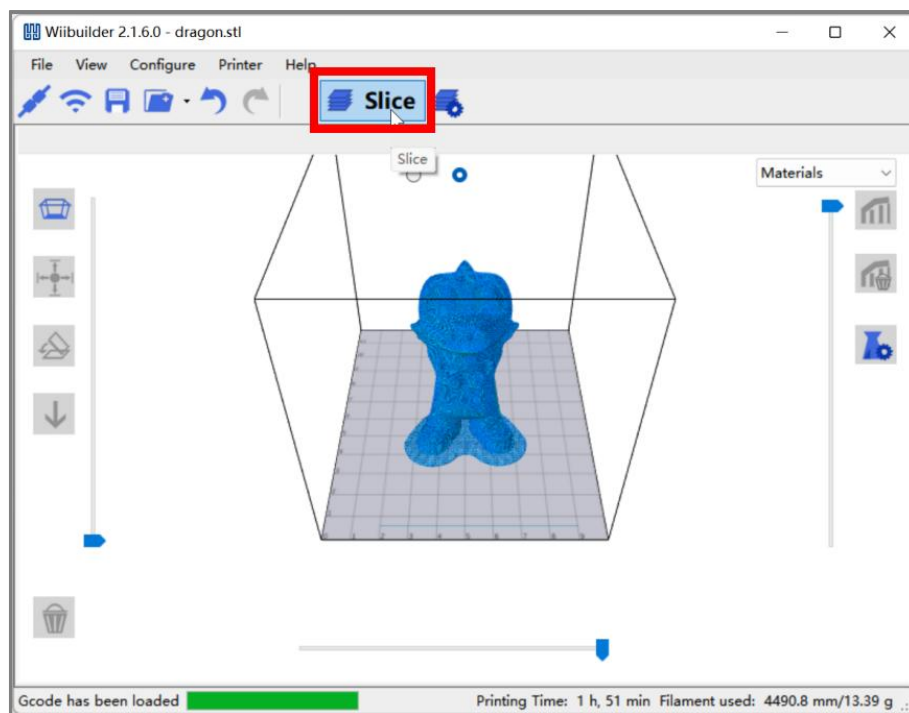

## 6.8. Send Files via Network

NOTE: THE 3D PRINTER HAS BEEN CONNECTED TO THE NETWORK, AND THE IP ADDRESS IS DISPLAYED. FOR OPERATIONS, PLEASE REFER TO: "PRINT BY APP".

SELECT THE COMPUTER TO USE THE SAME NETWORK AS THE DEVICE. USING DIFFERENT NETWORKS CAN CAUSE TRANSFER FAILURES.

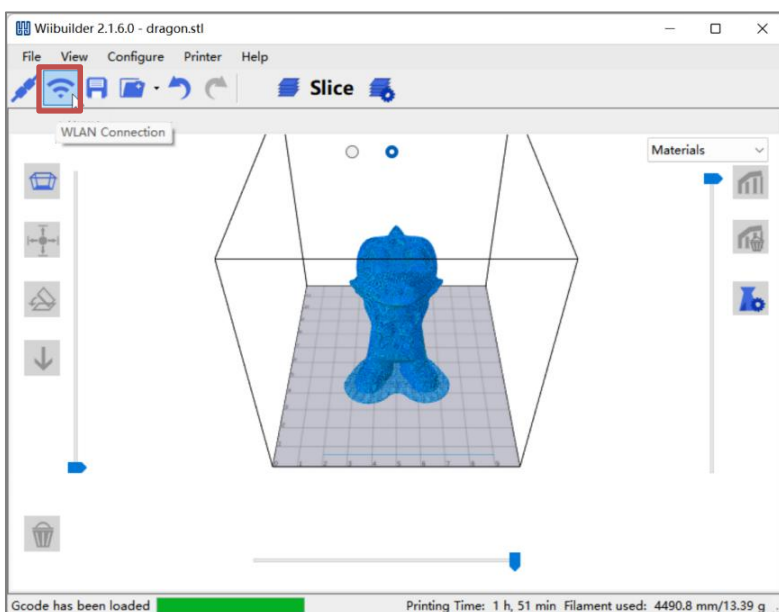
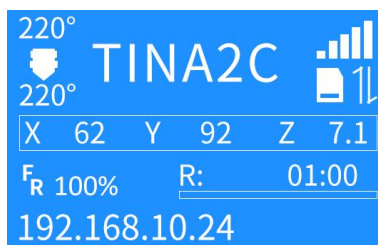

Click "WLAN Connection", the software will automatically search for the 3D printers in the local network and show them in the below list. If no 3D printer be found, you can also try to manually enter the IP address of the 3D printer to connect.

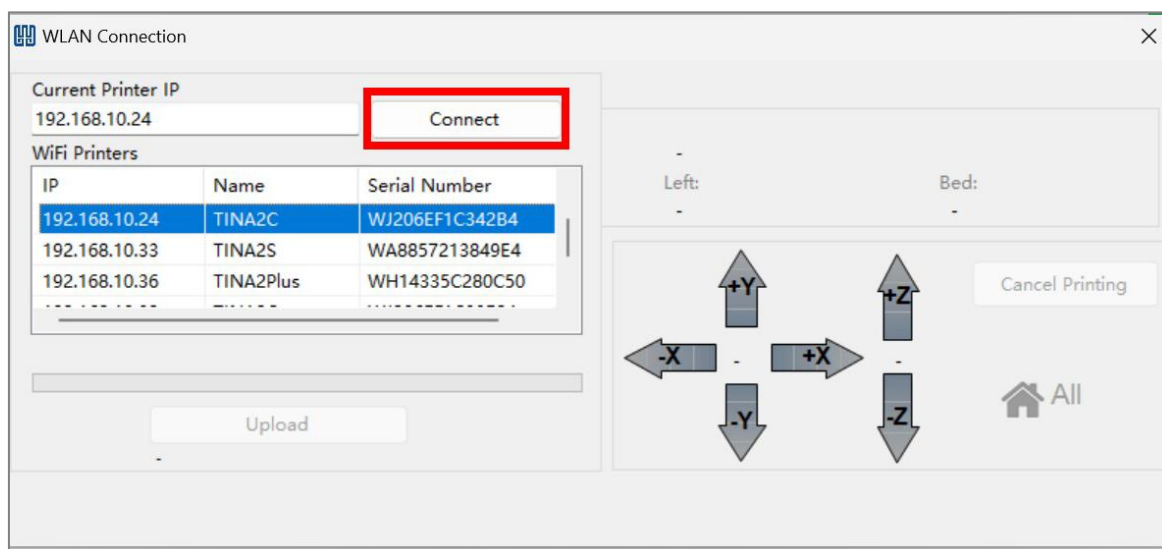

NOTE: IF YOU STILL CANNOT CONNECT TO THE 3D PRINTER, PLEASE CHECK WHETHER THE FIREWALL OF THE COMPUTER PROHIBITS THE SOFTWARE FROM NETWORKING, AND WHETHER THE COMPUTER AND THE 3D PRINTER ARE IN THE SAME LOCAL AREA NETWORK.

Send the sliced model to the 3D printer, and the 3D printer starts printing after receiving it.

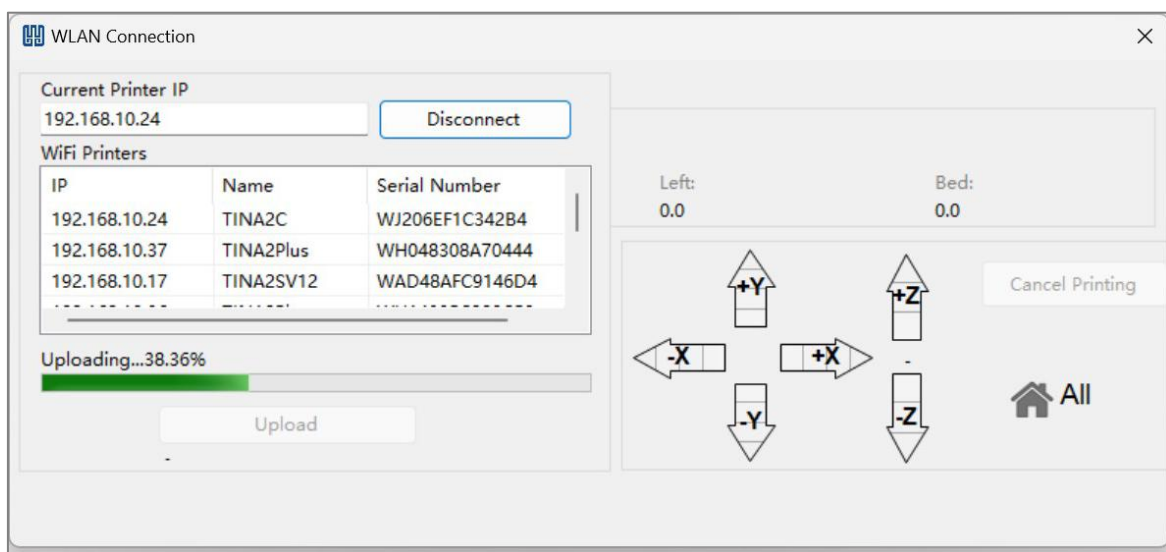
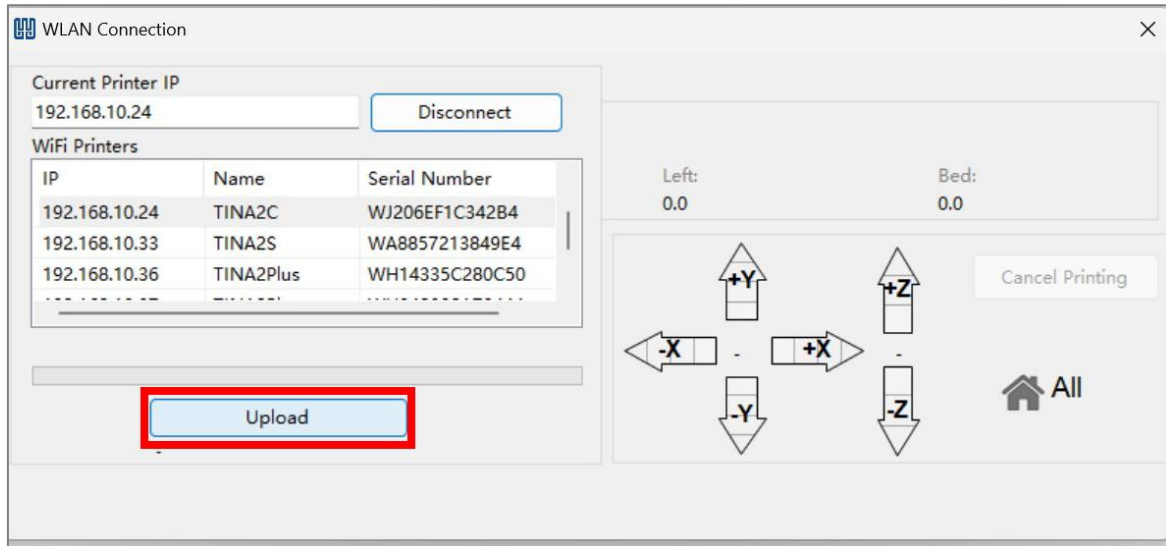

## 6.9. Send Files via TF Card

Save sliced model to TF card, insert card into printer.

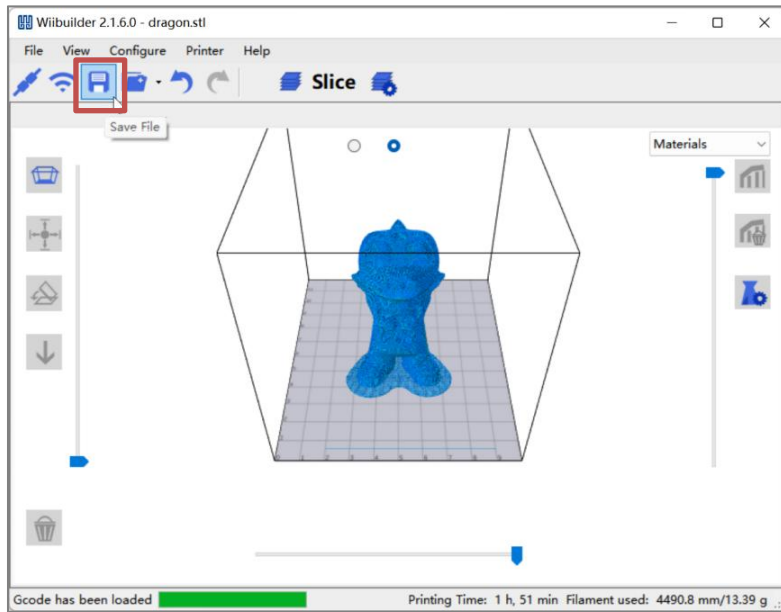

Note: Save directly to TF root, not in folder.

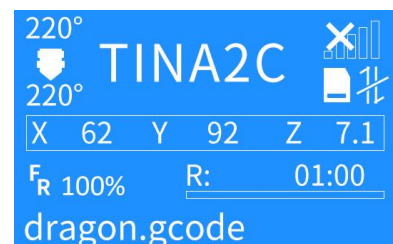
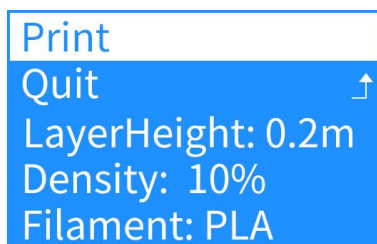
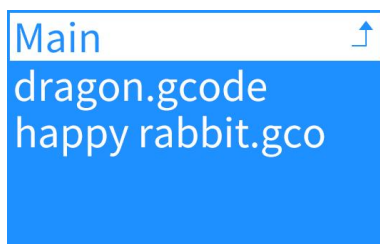
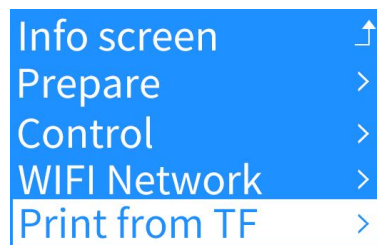
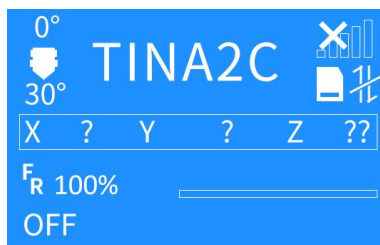
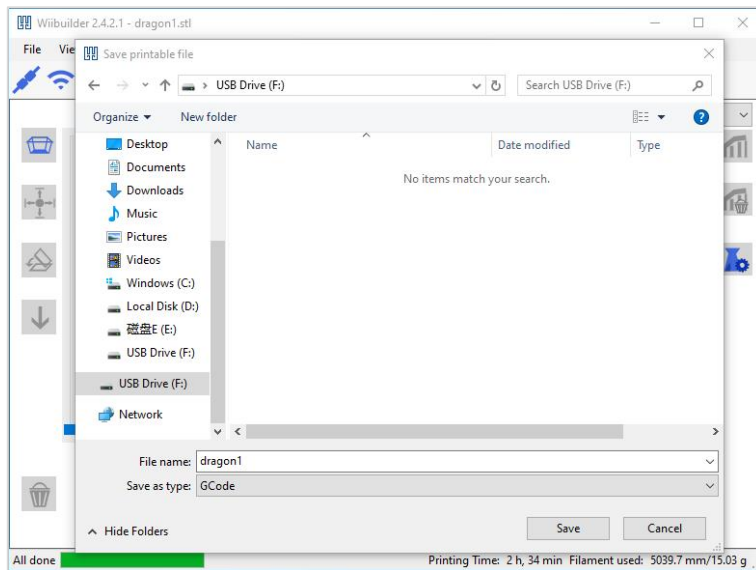

# 6.10.Advanced Parameter Settings

## 6.10.1.General

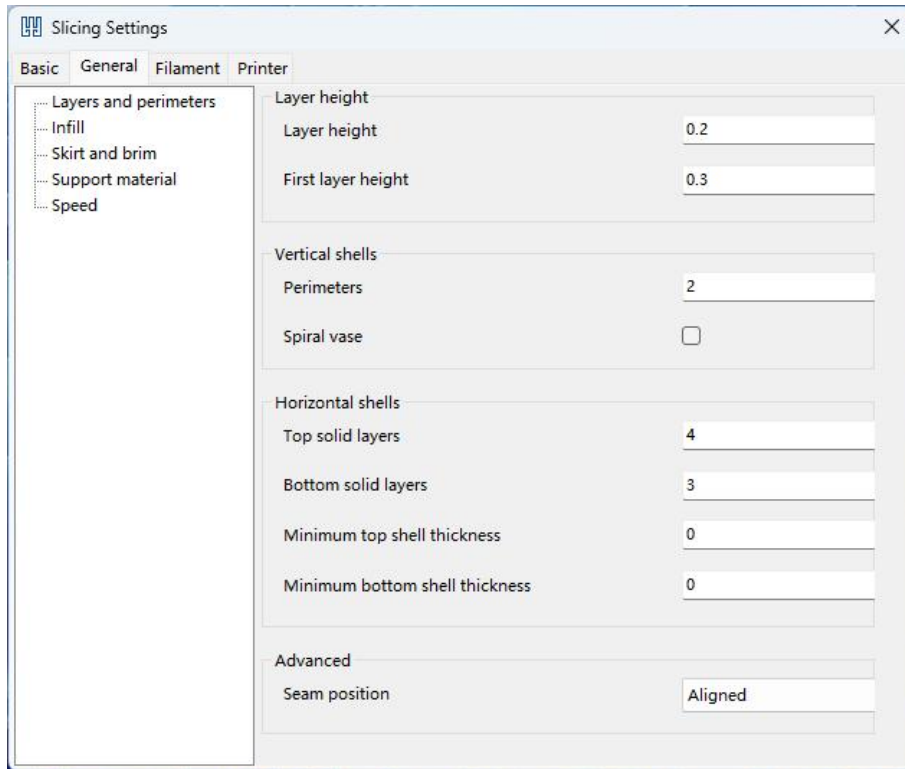

### 1. Layers and Perimeters:

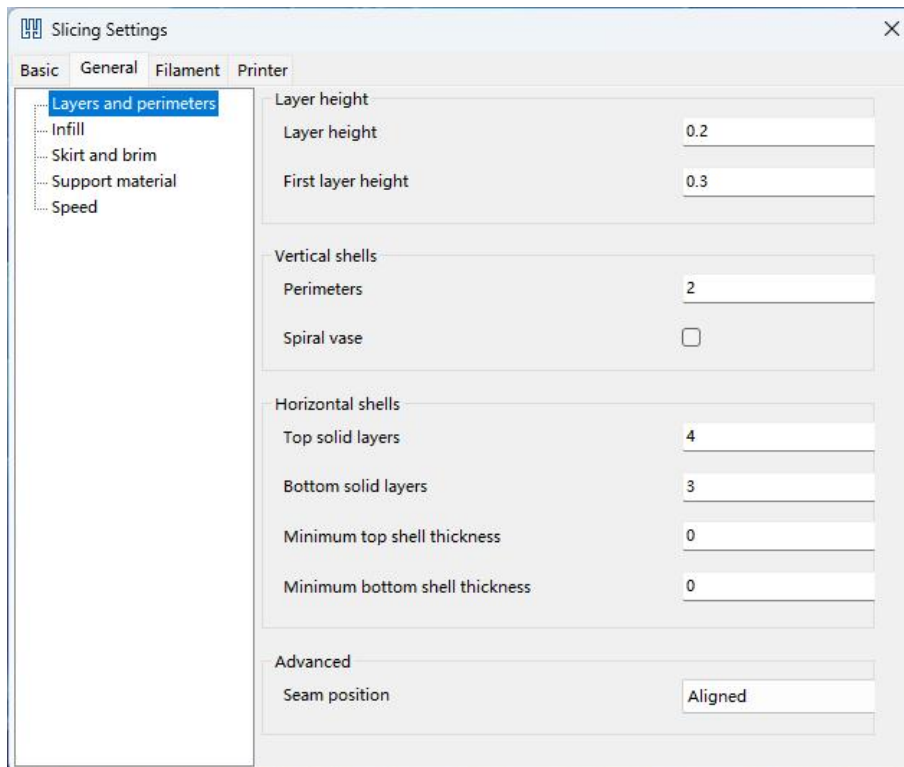

- **LAYER HEIGHT:** Determines the thickness of each printed layer. Lower values result in finer detail and smoother surfaces but increase printing time.

- **PERIMETERS/WALL LINE COUNT:** Sets the number of outer layers or walls of the print. Increasing this number enhances the model's strength and durability.
- **TOP LAYERS:** The number of solid layers printed on top of the infill. More top layers provide a smoother surface on the top of the print.
- **BOTTOM LAYERS:** The number of solid layers printed underneath the infill. More bottom layers ensure better adhesion to the print bed and a solid base for the print.

## 2. Infill:

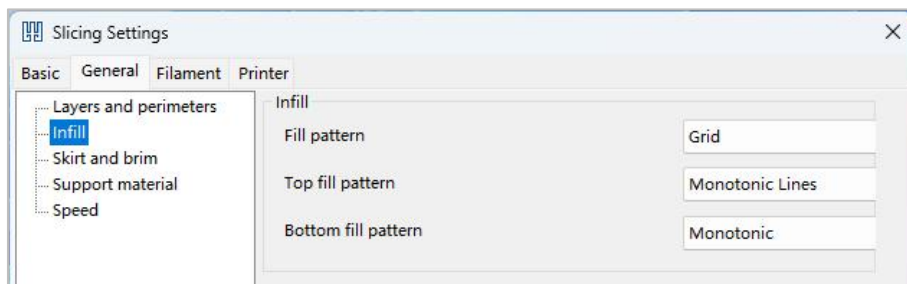

- **INFILL:** Select from Lines, Grid, Triangles, Zig Zag, Concentric, Cross, Octet. Patterns shown below.

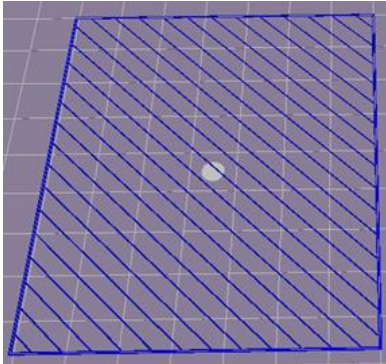
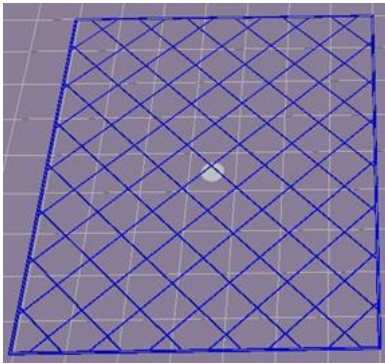
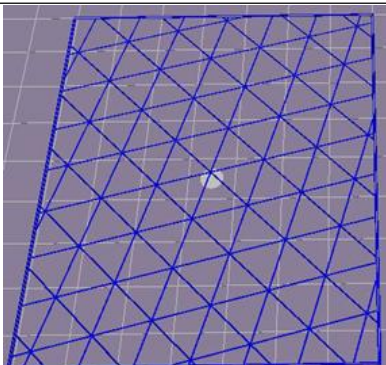
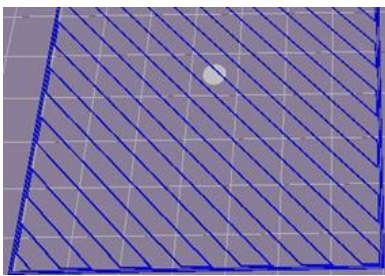
| Infill Patterns   |  |
|---|--|
|  |  |
| <b>Lines</b>  | <b>Grid</b>  |
|  |  |
| <b>Triangle</b>   | <b>Zig Zag</b>   |

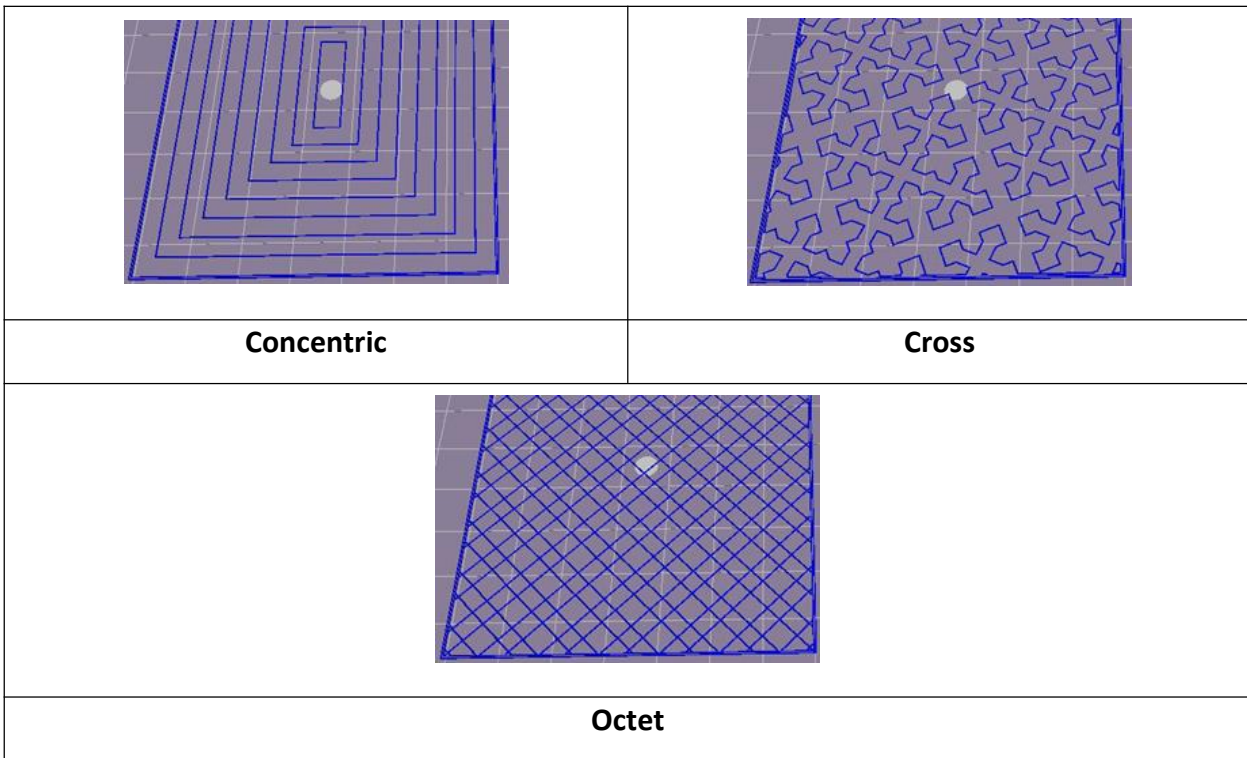

### 3. Skirt and brim:

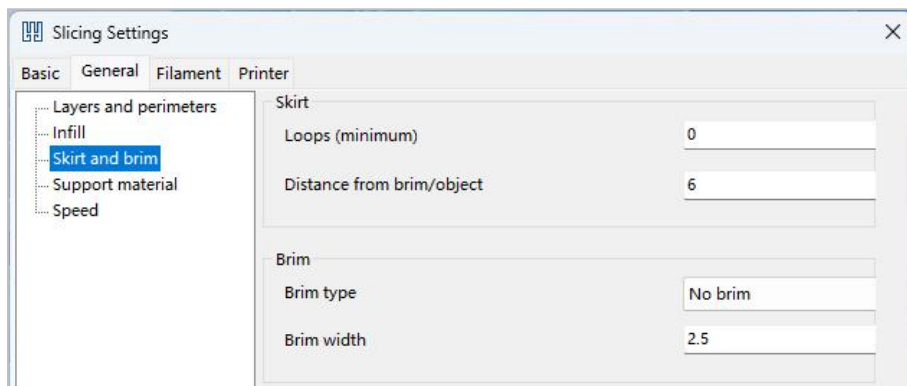

- **SKIRT:** A set of lines printed around the model but not in contact with it. It helps to prime the nozzle and checks the print bed adhesion before starting the actual print.
- **BRIM:** Adds a few rows of extra material around the base of the print to help with adhesion, particularly useful for prints with small contact areas or that tend to warp.

## 4. Support material:

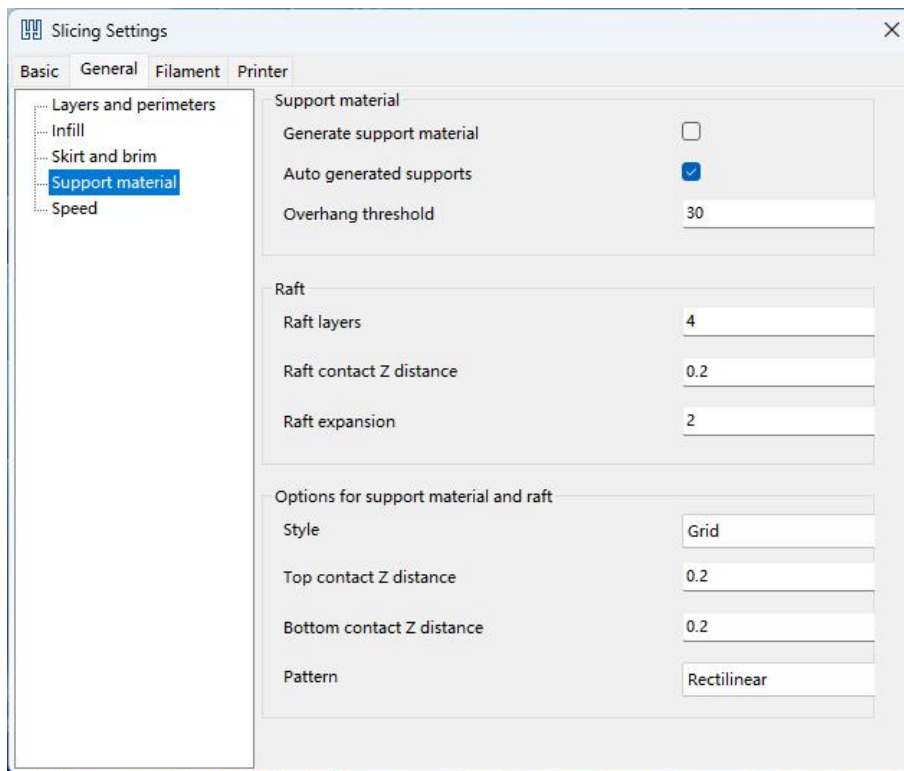

- **OVERHANG THRESHOLD (SUSPENSION THRESHOLD):** This setting defines the angle at which overhangs start to require support. For instance, if you set it to 45 degrees, any part of the model that extends beyond this angle will have support structures generated underneath it. This helps manage overhangs and prevents sagging or collapsing during printing.
- **RAFT LAYERS:** This setting specifies the number of layers of the raft that will be printed. Typically, a raft includes several types of layers:
- **RAFT CONTACT Z DISTANCE:** The Raft Contact Z Distance is an important setting that controls the vertical spacing between the raft and the model. This distance helps ensure that the raft serves its intended purpose—providing a stable and level base for the print—while also making it easier to remove the raft once printing is complete.
- **RAFT EXPANSION :** refers to a setting that controls the horizontal expansion of the raft beyond the dimensions of the model. This feature helps to improve bed adhesion and stability, especially for models with small bases or challenging geometries.

## 5. Speed:

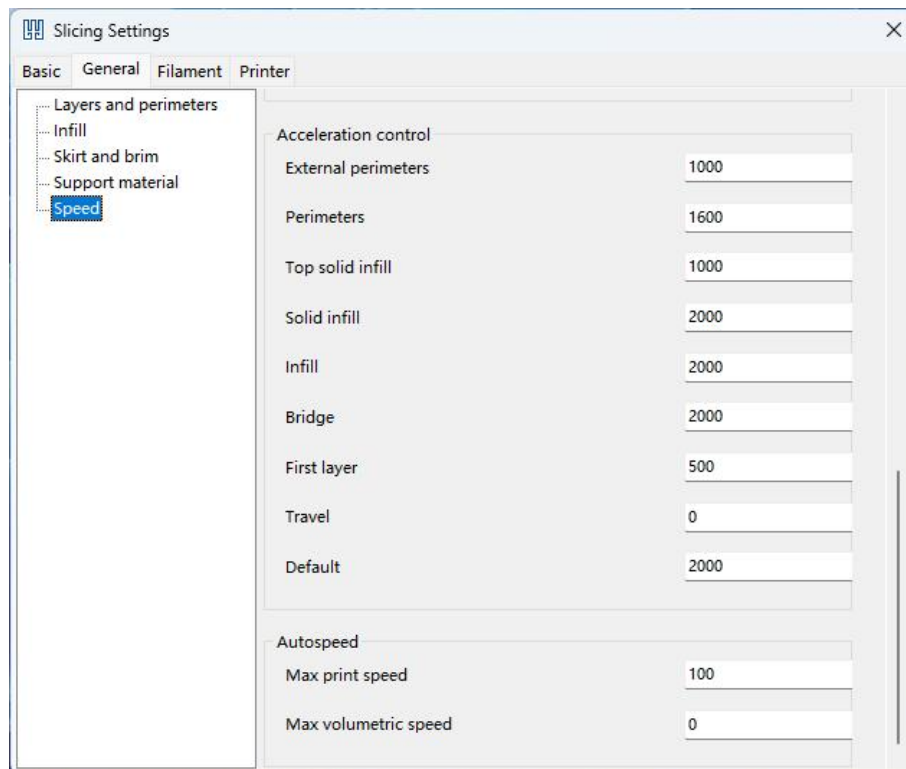

- **PERIMETERS SPEED (MM/S):** Definition: This setting controls the speed at which the printer moves while printing the perimeter layers of the model. Perimeters are the outer walls of the print. Typical Value: Often set between 30 to 50 mm/s. Slower speeds can improve the quality of the outer walls, resulting in smoother surfaces, but will increase print time.
- **SMALL PERIMETERS SPEED (MM/S):** Definition: This speed is specifically for printing small perimeters or narrow features of the model. These are typically areas where the width of the perimeter is narrower than usual. Typical Value: Generally lower than the standard perimeters speed to ensure higher precision and better quality for fine details. Values might range from 15 to 30 mm/s.
- **EXTERNAL PERIMETERS SPEED (MM/S):** Definition: This speed applies to the outermost perimeters of the model, which are the external walls. Printing external perimeters slower can enhance the quality of the visible surfaces. Typical Value: Usually set lower than the general perimeters speed to achieve a smoother finish on the outer edges. Typical values might be between 20 to 40 mm/s.
- **INFILL SPEED (MM/S):** DEFINITION: This setting controls the speed at which the printer moves while filling the internal structure of the model. Infill patterns create the internal support structure of the print. Typical Value: Typically set between 40 to 80 mm/s. Faster infill speeds can reduce print time but might impact the quality and strength of the internal structure.
- **SOLID INFILL SPEED (MM/S):** Definition: Solid infill speed applies to the denser areas of infill where the printer creates a solid fill without gaps. This is usually for areas like the base or top layers where more material is used. Typical Value: Often slower than the general infill speed to ensure good adhesion and even filling. Common values are between 30 to 50 mm/s.

- **TOP SOLID INFILL SPEED (MM/S):** Definition: This speed is used specifically for the solid infill layers on the top of the model. These layers are crucial for a smooth and solid top surface. Typical Value: Usually set slower to improve the surface finish on the top of the print. Values might range from 20 to 40 mm/s.
- **SUPPORT MATERIAL SPEED (MM/S):** Definition: Controls the speed at which the printer moves while printing the support structures. Supports are used to prevent overhangs and provide stability for complex geometries. Typical Value: Often set between 20 to 40 mm/s. Slower speeds can improve the quality and reliability of the support structures.
- **SUPPORT MATERIAL INTERFACE SPEED (MM/S):** Definition: This speed applies to the interface layers of the support structures, which are printed between the support and the model. The interface layers provide a smoother surface for the underside of the model. Typical Value: Typically set slower than the general support material speed to ensure a good quality interface. Values might range from 20 to 30 mm/s.
- **RAFT MATERIAL SPEED (MM/S):** DEFINITION: This setting controls the speed at which the printer extrudes the material for the raft. The raft is a base layer printed underneath the model to improve adhesion and stability. Typical Value: Generally set between 20 to 40 mm/s. Printing the raft slower can help improve the adhesion to the print bed and the overall stability of the raft, leading to a more reliable foundation for the model.
- **RAFT MATERIAL INTERFACE SPEED (MM/S):** Definition: This speed is specifically for the interface layers of the raft material, which are the layers between the raft and the model. These layers are designed to provide a smoother surface for the model to adhere to. Typical Value: Usually set slower than the general raft material speed, often between 15 to 30 mm/s. Slower speeds for the interface layers can help achieve a smoother surface, enhancing the quality of the model's base.
- **BRIDGES SPEED (MM/S):** Definition: Controls the speed at which the printer extrudes material when printing bridges, which are horizontal or near-horizontal spans of material between supports. Bridges require careful handling to avoid sagging or collapsing. Typical Value: Often set between 20 to 40 mm/s. Slower speeds for bridges can improve print quality and reduce issues like sagging or stringing. However, you might need to balance this with the overall print time.
- **GAP FILL SPEED (MM/S):** Definition: This setting applies to the speed at which the printer fills in small gaps or incomplete areas in the model, often used in the final pass to cover holes or gaps in the print. Typical Value: Typically set between 30 to 50 mm/s. Gap fill speed is often higher than other detailed settings because these areas are generally less critical for fine detail but can still benefit from a balanced speed to ensure complete filling.

## 6.10.2.Filament

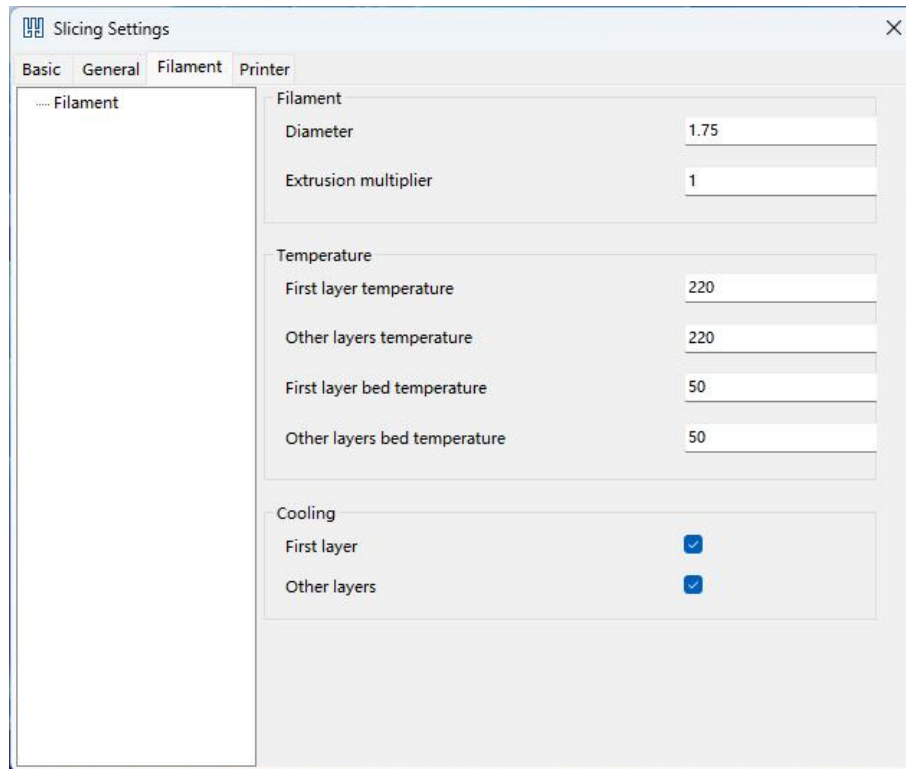

The diameter of the filament is fixed at 1.75 mm. The nozzle printing temperature and platform temperature can be modified.

PLA: Print Temp:180~220°C, Bed Temp:0~50°C

Silk PLA: Print Temp:210~230°C, Bed Temp:30~50°C

Gradient PLA: Print Temp:200~230°C, Bed Temp:40~50°C

Wood PLA: Print Temp:200~220°C, Bed Temp:40~50°C

PLA+: Print Temp:190~230°C, Bed Temp:30~50°C

PLA Pro: Print Temp:210~230°C, Bed Temp:30~50°C

TPU: Print Temp:190~235°C, Bed Temp:0~50°C

Applicable ambient temperature: 15~25°C

Winter: The temperature is lower than 15°C, which will cause the filament to become hard and brittle, not to come out, and will not stick. In order to ensure smooth silk output, it is necessary to increase the nozzle temperature by 10°C, set the platform temperature to 60°C, adjust Z-offset and apply glue. (Tina2 Basic adjusts the Z-offset, increases the first layer by 15~20°C, and increase the indoor temperature)

Summer: If the temperature exceeds 25°C, it will cause problems such as stringing and clogging.

Please lower the nozzle temperature appropriately. Summer will be more humid, and Silk PLA is easily affected by moisture. Please use it as soon as possible or store it in a sealed container.

### 6.10.3. Infill Tab

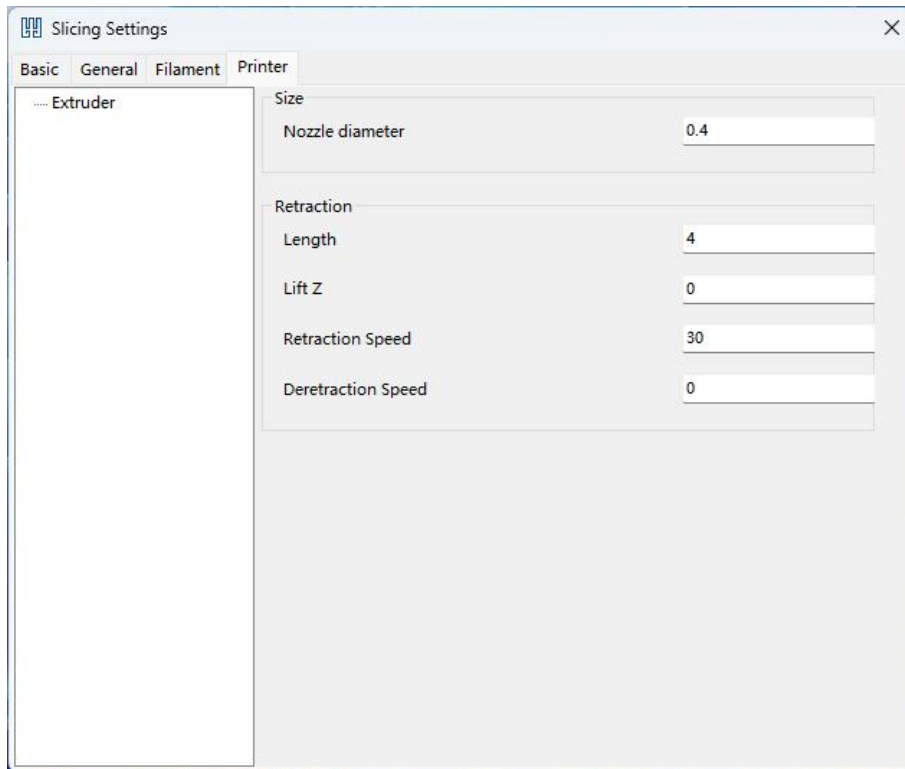

The nozzle diameter is fixed at 0.4mm.

- **RETRACTION LENGTH:**

Definition: The distance that the filament is pulled back into the nozzle during a retraction. This helps prevent oozing and stringing by reducing the pressure in the nozzle when moving between print areas.

Typical Values: Usually ranges from 0.5 to 6 mm, depending on the printer and filament type.

Shorter Lengths: Suitable for flexible or soft filaments to avoid jamming and clogging.

Longer Lengths: Often used for more rigid filaments like PLA or ABS to effectively reduce stringing.

Impact: Proper retraction length prevents excess filament from oozing out of the nozzle during travel moves, which improves print quality and reduces defects.

- **RETRACTION LIFT Z:**

Definition: The vertical distance that the nozzle lifts while retracting the filament. This is intended to avoid dragging the nozzle across the print and potentially damaging it.

Typical Values: Usually set between 0.5 to 2 mm.

Smaller Values: Minimizes lifting, which can be suitable for prints with close spacing or delicate details.

Larger Values: Helps in avoiding nozzle contact with the print, especially when moving across tall features or intricate details.

Impact: Proper lift Z helps reduce the risk of nozzle scraping or damaging the print, which is particularly useful when traveling over delicate or detailed parts of the model.

- **RETRACTION RETRACTION SPEED:**

Definition: The speed at which the filament is retracted and pushed back into the nozzle. This setting affects how quickly the printer can respond to changes in extrusion.

Typical Values: Ranges from 20 to 100 mm/s.

Slower Speeds: Provide more controlled retraction and can reduce the risk of clogging, especially for flexible filaments.

Faster Speeds: Reduce print time by quickly retracting and re-engaging the filament, but may increase the risk of filament grinding or jamming if set too high.

Impact: Optimal retraction speed prevents stringing and reduces the chances of filament issues, contributing to cleaner prints with fewer defects.

- **RETRACTION DERETRACTION SPEED:**

Definition: The speed at which the filament is reinserted into the nozzle after retraction (also known as “deretraction” or “un-retraction”). This affects how quickly the nozzle starts extruding again after a move.

Typical Values: Usually similar to or slightly different from retraction speed, often between 20 to 100 mm/s.

Matching Speed: When set the same as the retraction speed, it ensures consistent filament flow and helps avoid gaps or inconsistencies in extrusion.

Different Speed: Adjusting it can help fine-tune how quickly the filament resumes extruding, which can be useful for specific materials or print quality improvements.

Impact: Proper deretraction speed ensures smooth transition back to extrusion, reducing the risk of defects such as gaps or blobs in the print.

## **7.CURA**

### **7.1.Installation**

Another good slicer for Tina2C. Models sliced in Cura can't preview File Info screen. Custom Cura installer on microSD for Windows and Mac.

OS: Windows 10+ / MacOS 11.7+

#### **7.1.1.Installation on Windows**

Double-click exe on microSD, then:

Welcome dialog > Next > I Agree

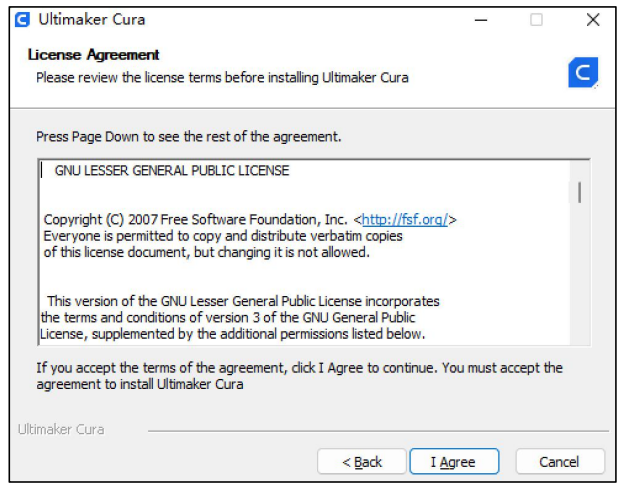
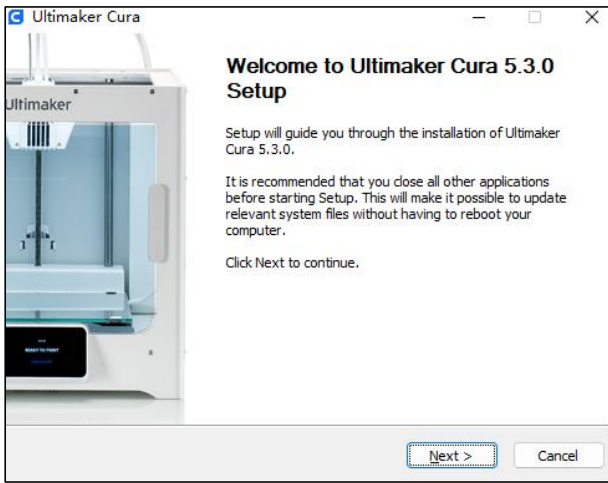

Choose install directory > Next

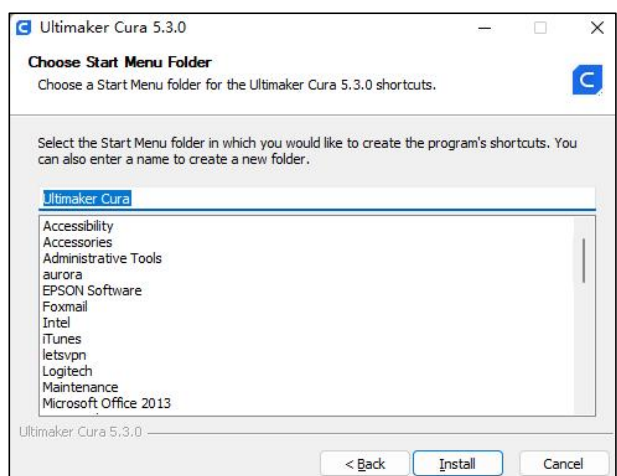
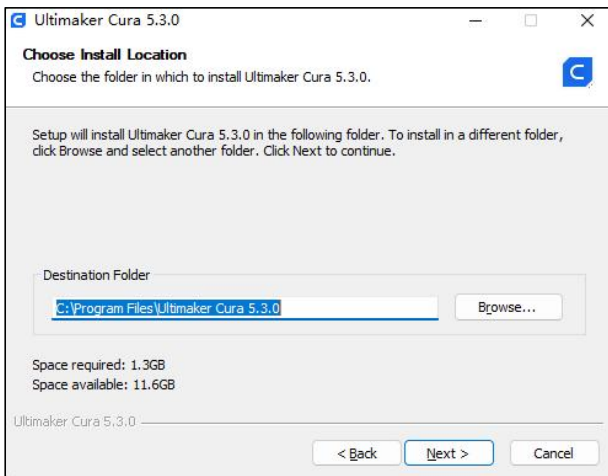

Select file associations > Install. Approve driver install if prompted. Check Run Ultimaker Cura > Finish.

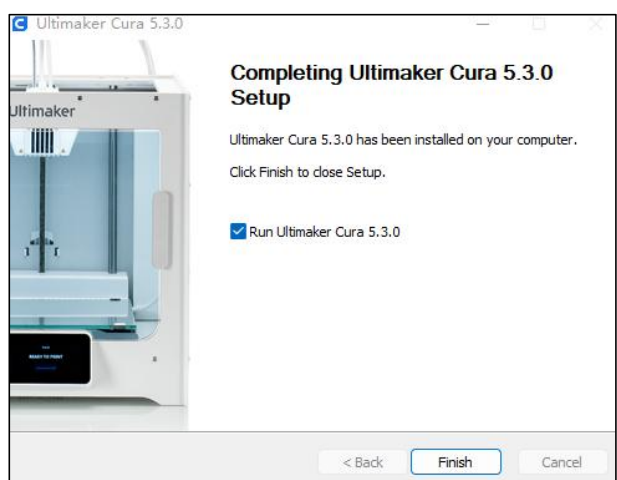
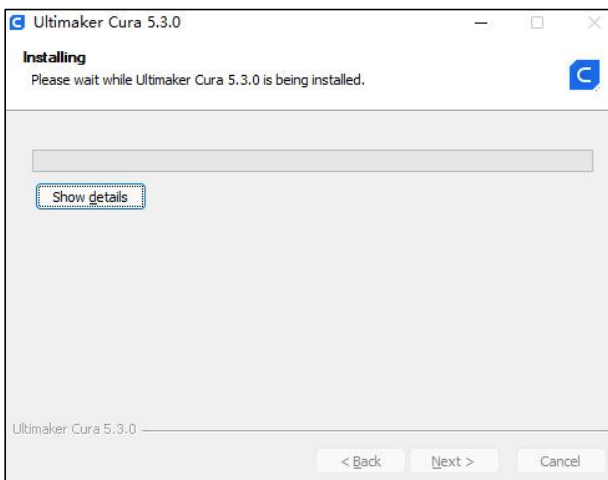

Welcome dialog > Get Started. User Agreement > Agree. If reinstalling, skip to step 6.

## User Agreement

**Disclaimer by UltiMaker**

Please read this disclaimer carefully.

Except when otherwise stated in writing, UltiMaker provides any UltiMaker software or third party software "As is" without warranty of any kind. The entire risk as to the quality and performance of UltiMaker software is with you.

Unless required by applicable law or agreed to in writing, in no event will UltiMaker be liable to you for damages, including any general, special, incidental, or consequential damages arising out of the use or inability to use any UltiMaker software or third party software.

Decline and close
Agree

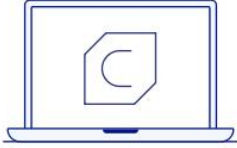

## Welcome to UltiMaker Cura

Please follow these steps to set up UltiMaker Cura.  
This will only take a few moments.

Get started

Next on next two dialogs

## Help us to improve UltiMaker Cura

UltiMaker Cura collects anonymous data to improve print quality and user experience, including:

Machine types



Material usage



Number of slices



Print settings



Data collected by UltiMaker Cura will not contain any personal information. [More information](#)

Next

Ultimaker Cloud dialog for account creation/login > Skip

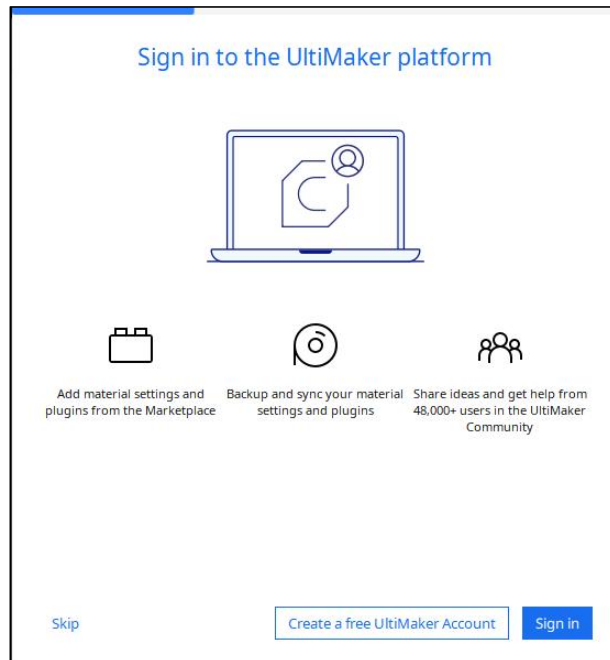

Add networked printer > Entina > TINA2 > Next. If First Run skipped, Settings > Printer > Add > Tina2 > Add, skip to step 8.

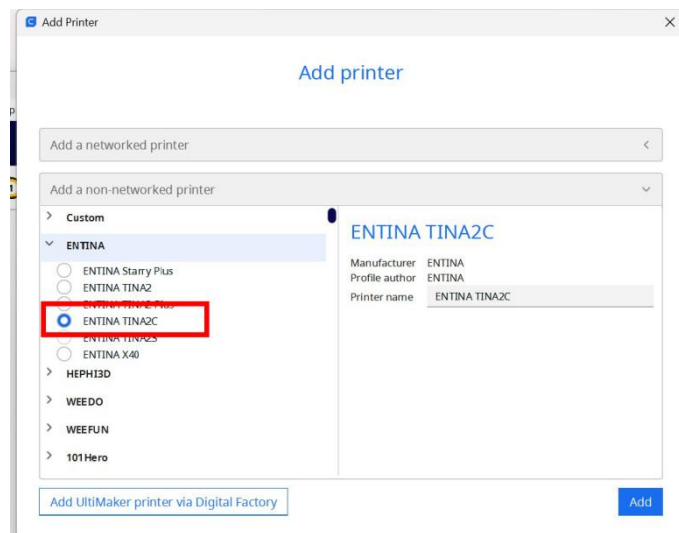
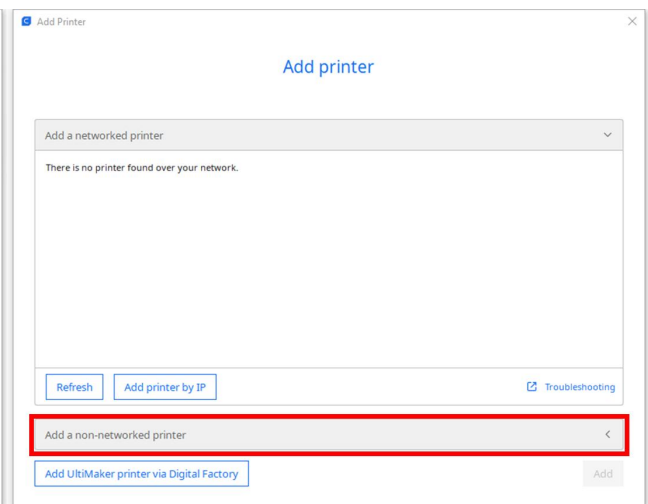
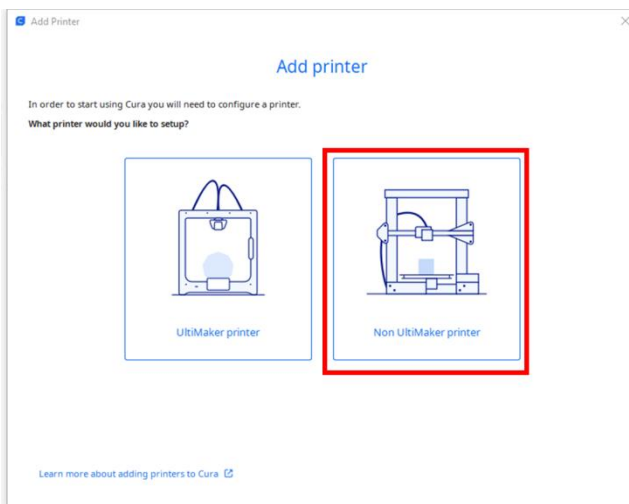

Main screen loads with Tina2 defaults. To customize, click pencil > Custom. Infill Density, Support, Platform Adhesion based on model needs.

Infill Density: Overall strength. Low for decorative, high for functional parts.

Support: None for no overhang (cube), Touching Buildplate for plate overhang only, Everywhere for complex overhang.

Platform Adhesion: Brim usually sufficient and easier cleanup. Raft builds sacrificial base layer.

Experiment for best results.

Install complete! See Cura docs for operation details.

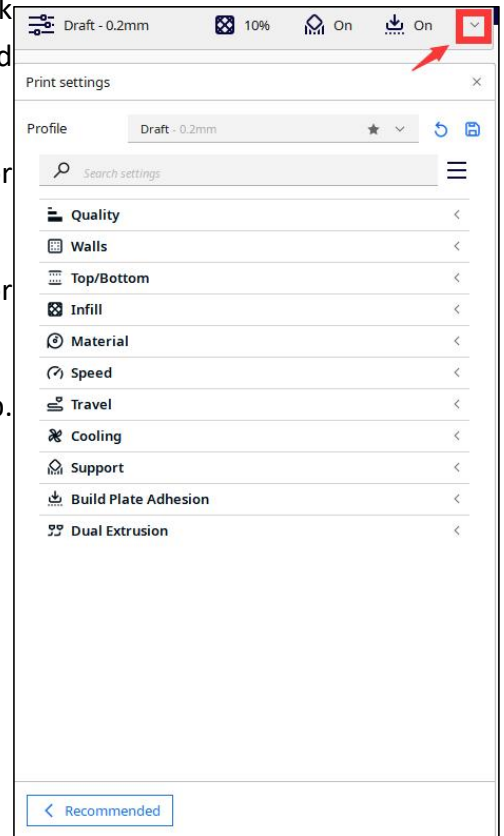

## 7.1.2. Installation on MacOS

OS: MacOS 11.7+

Decompress installer. Double-click package, drag Cura to Applications.

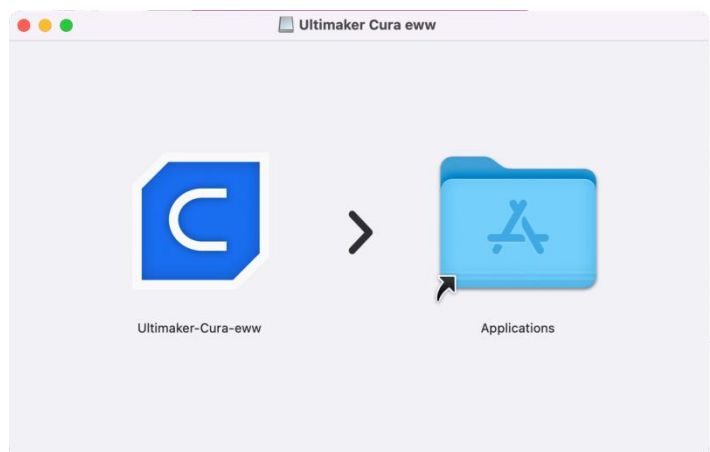

## 7.2. Interface Introduction

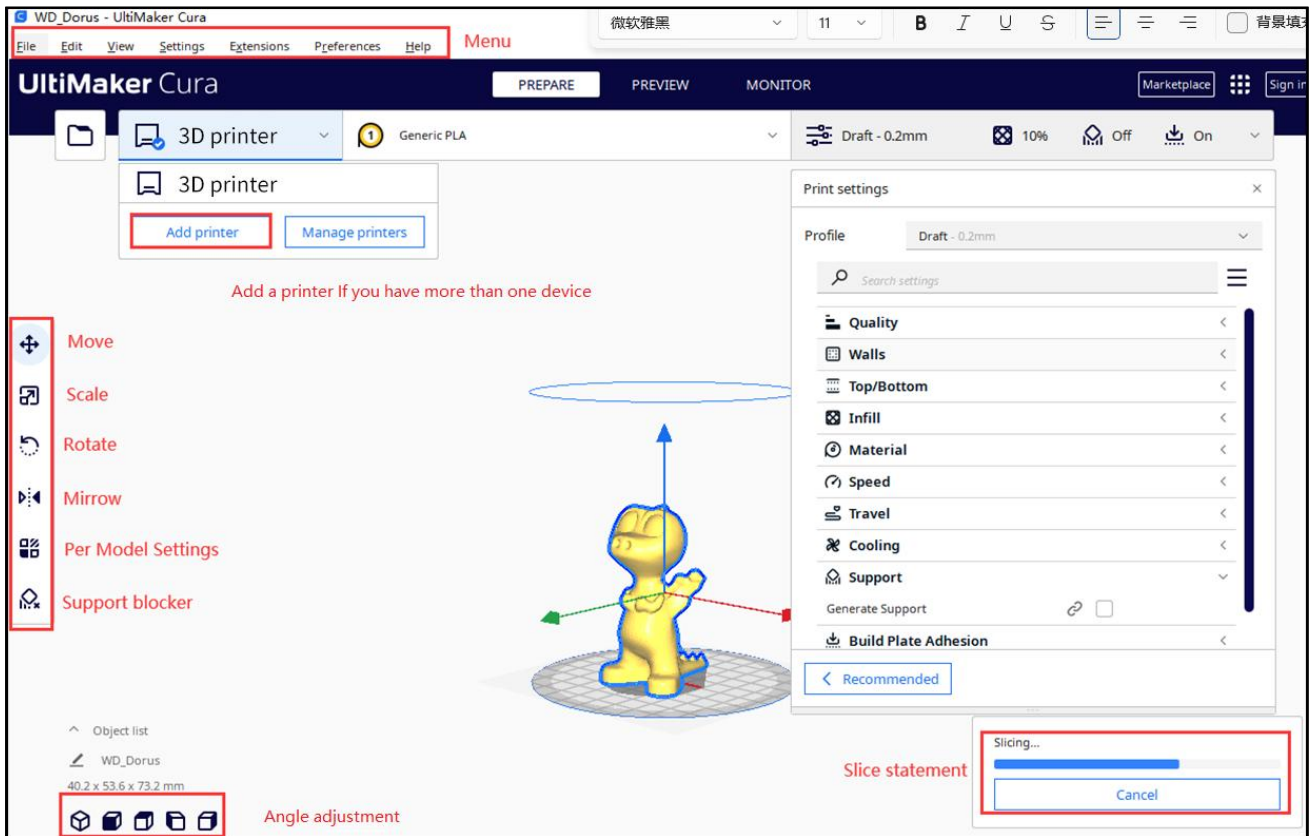

- Menu Bar: Access Cura menu
- Move, Scale, Rotate, Mirror: Adjust model size and position
- Support Blocker: Manually add supports

Right-click model for context menu:

- Center Selected: Auto-center model on platform
- Delete Selected: Remove model
- Multiply Selected: Duplicate multi-part model
- Arrange All Models: Auto-adjust multiple model position and spacing
- Clear Build Plate: Remove all models

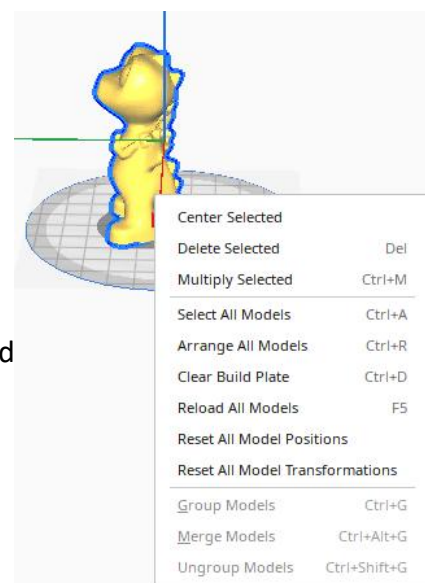

## 7.3.Add Model

Open Cura, click File to load model or drag model in.

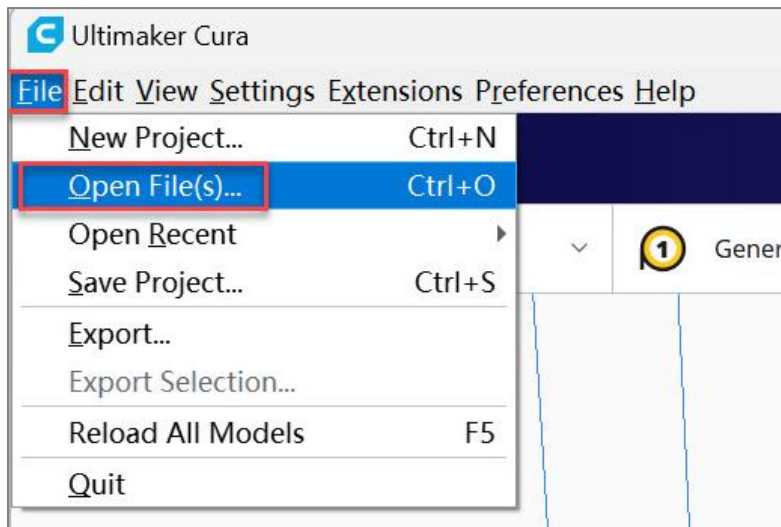

## 7.4.Adjust Model

Click model to adjust size, angle, position.

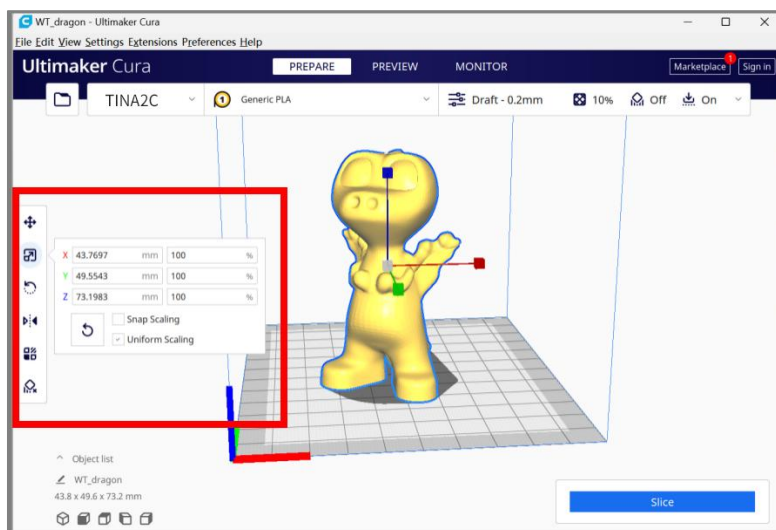

## 7.5.Slice

Beginners use defaults without adjustment.

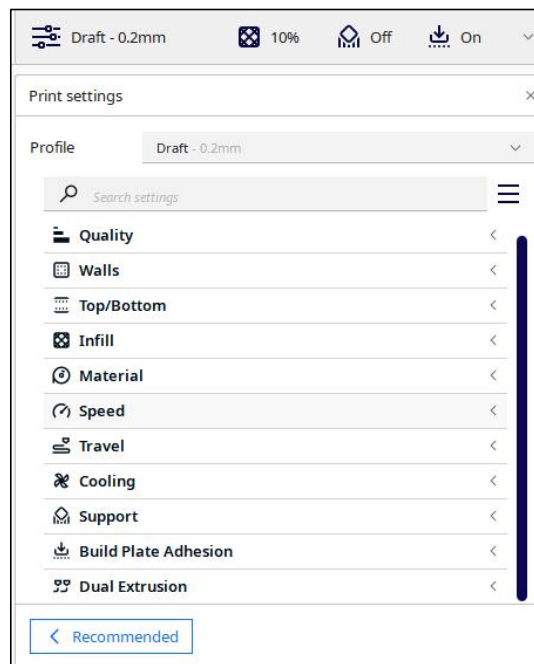

After setting parameters, click Slice to process.

