

Manual / quick
reference guide

For Vacuvita Home Base,
vacuum containers and vacuum bags

vacuvita®

www.vacuvita.com

Welcome to the Vacuvita easy access storage system!

Keep food fresh and healthy

Vacuvita is based on a simple fact - when you remove oxygen, food stays fresh up to five times longer. Vacuvita is a fully-automatic vacuum food storage system. By removing air and storing food in an airtight environment you protect your food against humidity and other outside influences. Cookies and chips stay crispy, coffee beans keep their wonderful smell and fruits and vegetables retain their rich flavours. Placing food in a vacuum bag will prevent freezer burn, which is caused by dehydration and oxidation that occur when storing food in the freezer.







The Vacuvita easy access vacuum storage system is one of a kind. Just one touch is enough to release the vacuum immediately. The Vacuvita Home Base's lid will open by itself so you can access your food within seconds. The springs and dampers are perfectly balanced for smooth opening and one-handed closing of the cover. Creating a vacuum is as easy as closing the lid. Your Vacuvita system can be expanded to your fridge and freezer with our specially designed Vacuvita containers and vacuum bags.

Because Vacuvita is so versatile and easy to use, you will find yourself eating fresh foods more often.

Please carefully read this manual to ensure that you will use your Vacuvita products in the most effective and safe way and get the best results possible.



vacuvita®

-  **Reduce food waste**
Care for the environment
-  **Keep food fresh**
Up to 5 times longer
-  **Cook like a chef**
Marinating, sous vide cooking and mis-en-place
-  **Keep track & get notified**
With our unique app and container coding system
-  **Ease of use**
With our one touch to open and easy close for instant vacuum functionality
-  **Engineered to suit your life**
 - > High vacuum level
 - > High quality materials
 - > Expand the system with additional bags and containers

Important safety instructions

Please carefully read this user manual before using this product and keep it for future reference. When using your Vacuvita products, always take basic precautions, including the following:

1. Use the Vacuvita Home Base and vacuum bags only for their intended purpose, as described in this manual.
2. Do not use the appliance on wet or hot surfaces or near a heat source.
3. Place the device on a stable and flat surface. Caution: position the cord where it cannot be tugged, cause the user to become entangled, or cause the product to be overturned.
4. To protect against the risk of electric shock, do not immerse any part of the Home Base, power cord or plug into water or other liquids.
5. Do not suck liquids into the system, this will damage the Home Base and all warranties concerning operation and safety are invalidated.
6. Carefully maintain the Vacuum adapter and keep it clean.
7. Always unplug the device before cleaning.
8. Never pull the cord to disconnect the Home Base from the outlet. Unplug the device by removing the plug itself.
9. Do not operate the appliance with a damaged power cord or plug. Do not operate the device if it malfunctions or is damaged. Contact us at service@vacuvita.com for the address of the nearest Authorised Service Center for examination, repair or adjustment. The device should not be serviced by the user.
10. Closely supervise children when using any electrical appliance. Do not allow the appliance to be used as a toy.
11. Do not use the Home Base outdoors
12. Do not put the Home Base in a refrigerator or freezer
13. Keep Vacuvita Home Base and other Vacuvita products and packaging away from animals and small children. There is a danger of suffocation.
14. Do not let the cable or adapter tube hang over the edge of a worktop, to prevent entanglement or tripping.
15. Do not use an extension cable.
16. Only use Vacuvita vacuum containers in combination with the Vacuvita Home Base. Using other vacuum sealers to create vacuum can damage the container.
17. Vacuvita container bases (but not the lids) are designed to be microwave-safe, however they are not intended for cooking. Do not use the containers in a conventional oven or under the grill.

Quick Manual

Unpacking

Vacuvida Home Base

The Vacuvida Home Base is designed as a convenient and stylish stand-alone unit to preserve dry and crispy products.

Power Adapter

The Home Base is powered by a 14V DC adapter to create and maintain your vacuum in the Home Base and to enjoy using your Vacuumbags and Containers. The Power adapter is suitable for an input voltage is between 110V-230V.

Vacuum adapter

The vacuum adapter quickly and easily connects the additional storage units, such as the Vacuvida containers or vacuumbags, to the Home Base. This vacuum adapter allows you to use our external vacuum solutions for long-term storage in the pantry, fridge or freezer.

Vacuumbags

Vacuvida vacuum bags are BPA- and BPS-free and come in a variety of convenient sizes. Your Home Base comes with five medium bags (2 quarts) and five large bags (1 gallon).

Fully expand your vacuum storage solution with Vacuvida Containers

Containers

Vacuvida Containers are BPA- and BPS-free and come in three different sizes: Small (x Gallon), Medium (x Gallon) and Large (x Gallon).



Setting it up

Plug and play // Homebase

- Remove all packaging and foils from Homebase and power adapter. Some parts of product packaging are eligible for recycling. Keep packaging away from small children.
- Position the Vacuvida Home Base on a flat surface with the lid closed. Place the plug from the power adapter into the socket at the back of the appliance and plug the other end of the power adapter into a power outlet.
- The circular indicator LED light rings on the top of the Home Base will briefly blink to indicate that the power is on. (see picture)
- The blue indicator lights behind the control button will switch on and you will hear a short two-tone sound. (see picture)

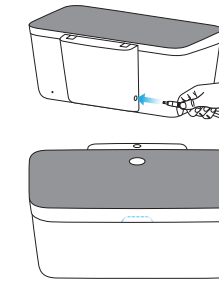

Quick check Homebase:

- When the lid of the homebase is closed, you will hear the pump automatically removing the air from the Home Base - the vacuum process has started.
- You can interrupt the vacuum process at any time by simply pushing the easy access control button at the front of the unit to open the lid.
- Pressing the easy access control button releases the vacuum and opens the lid automatically.

You are ready now to store your food in the Homebase, more info can be found in chapter xx.

For full instructions, see chapter xx for more functionalities of the Adapter and Vacuumbags

Important for vacuum food storage

- Do not store fresh onions, garlic, soft cheeses or mushrooms in Vacuvida Home Base or Vacuvida accessories.
- Vacuvida Home Base and other Vacuvida products are not a substitute for refrigeration or freezing. Perishables still need to be kept in the refrigerator or freezer. Vacuum packaging is not a substitute for canning.
- Always allow food to cool to room temperature before applying the vacuum.
- Do not allow water or liquids inside the Vacuvida Home Base as well as the Power and Vacuum tube. Do not submerge the Home Base or Vacuum adapter in water
- Always allow food to cool to room temperature before applying the vacuum.
- Do not use any accessories other than Vacuvida accessories, as they are specifically designed to be used with our high performance vacuum equipment.

Plug and play // Vacuumbags

- Remove all packaging and foils from the vacuum hose and vacuum adapter. Some parts of product packaging are eligible for recycling. Keep packaging away from small children.
- Connect the vacuum tube to the vacuum adapter (picture)
- Simply plug the free end of the vacuum tube in the Home Base and press- the circular indicator LED light rings will light up when the vacuum tube is attached properly (picture)

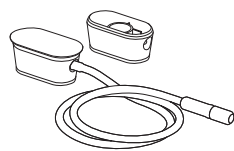

Quick check Vacuum adapter:

- Place the adapter on the black top of the Vacuvita Homebase and touch in the middle of the circular LED rings and the Home Base will start removing air via the vacuum adapter. During the vacuum process, the light rings blink to indicate that the vacuum is being created.
- The pump will automatically switch off after the vacuum level has been reached. The circular LED rings however will remain switched on to enable you to vacuum another container or bag;
- Make sure no liquids enter the vacuum tube: always check that the vacuum adapter is dry before use (Warranty)
- Please note that the LED rings will switch off after 15 minutes.

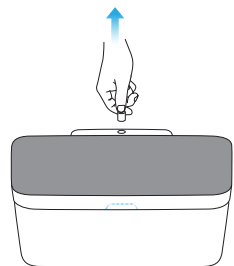

Quick check Vacuumbags

- Close the bag with the ziplock
- Place the vacuum adapter on the designated area. (picture)
- Touch in the middle of the circular LED rings and the Home Base will start removing air from the vacuum bag via the vacuum adapter. During the vacuum process, the light rings blink to indicate that the vacuum is being created.
- Press the adapter firmly on the bag during the vacuum process.
 - If the Homebase switches off while there is still air in the bag, please retry, the adapter might have been misaligned.
 - If you don't see any air removing from the bag, please be patient it may take a while before the bag is wrapped. Otherwise check again if your ziplock is closed properly and retry.
- The pump will automatically switch off after the vacuum level has been reached. The circular LED rings however will remain switched on to enable you to vacuum another container or bag.
- To release the vacuum from the bag, gently open the ziplock on the top of the bag.

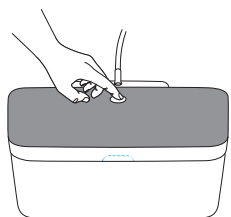
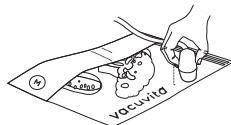

During the vacuum process small crumbs, food particles or drops of liquid may be pulled into the vacuum system. It is recommended that

you regularly clean and thoroughly dry the adapter, especially after using it on bags containing liquids.

Do not attempt to detach the tube from the adapter.

For full instructions, see chapter xx Need to know how to preserve your food in the Vacuumbags? See Chapter xx

Plug and play // Containers

Quick check Containers

- Put the lid on the container.
- Place the vacuum adapter on the designated area (picture)
- Touch in the middle of the circular LED rings and the Home Base will start removing air from the container via the vacuum adapter. During the vacuum process, the light rings blink to indicate that the vacuum is being created.
- Press the adapter firmly on the container for about 5 seconds.
 - At first time use, or after replacing the seal in the lid, it might take a little longer to create vacuum in the containers. Indication of vacuum time of an empty container:
 - 1L: +- 30 seconds
 - 2L: +- 45 seconds
 - 4L: +- 90 seconds

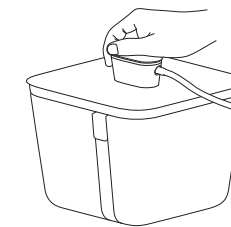

- The pump will automatically switch off after the vacuum level has been reached. The circular LED rings however will remain switched on to enable you to vacuum another container or bag.
- To release the vacuum from the container, gently pull the grey valve on the top of the lid. You will hear the air release. When all vacuum is released you can take the lid from the container.

Need to know how to preserve your food in the Containers?

See Chapter xx

For full instructions, see chapter xx for more functionalities Containers

Content

Home Base

Using your Vacuvita Home Base	15
Cleaning the Home Base	16
Cleaning the dust and particle filter	17
Cleaning or replacing the removable air filter	17
Emergency vacuum release	18
Standby mode	18

Vacuum bags

Using the Vacuvita Home Base with vacuum bags	19
Cleaning the vacuum adapter	20

Vacuum containers

Using the Vacuvita Home Base with vacuum containers	21
How to scan your containers: Using the QR code	22
Cleaning the container	23
Cleaning and re-installing the seal	23
Cleaning the valve	24

Troubleshooting

Storage chart

Food Safety Tips

25
26
29

Warranty

30	
1 year Limited Warranty	30
What are the limits of Vacuvita's Liability?	30
How to Obtain Warranty Service	31



Vacuvita Home Base

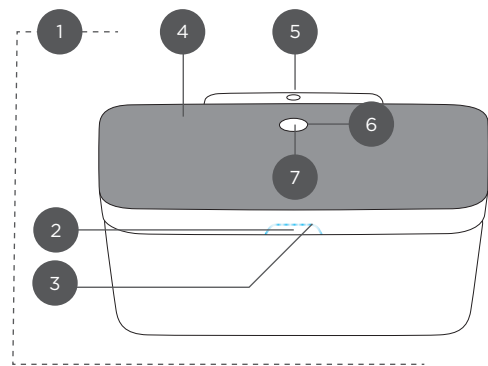

1. Vacuvita Home Base
2. Easy Access control button, to automatically open the lid and release the vacuum
3. Blue indicator light
4. Home Base lid
5. Adapter socket (with removable cap)
6. Circular indicator LED light rings
7. Capacitive touch control to enable the "external vacuum" function

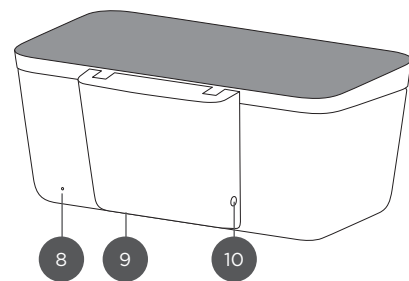

8. Emergency vacuum release switch
9. Air outlet with replaceable air filter
10. Power inlet

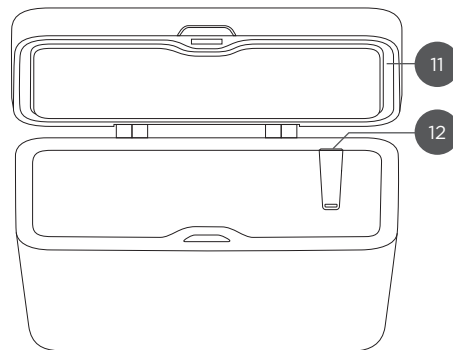

11. Lid seal
12. Dust and particle filter

Power adapter

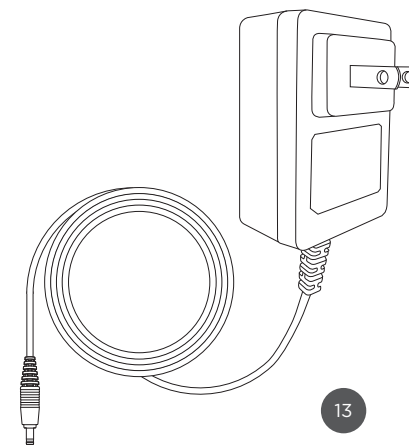

13. 14V/1.5A Power adapter

How to use your Homebase

Using your Vacuvita Home Base

- Open the Vacuvita Home Base by pressing easy access control button.
- There will be a brief sound of air being released and the lid will automatically open within a few seconds.
- Place your food inside the Vacuvita Home Base. For advice on proper storage of different types of food, see 'Storage chart' page 26.

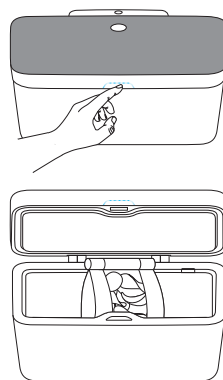

Always allow food to cool to room temperature before applying the vacuum.

- Close the Home Base by gently pressing down the lid.
- When the lid is closed, the blue indicator light behind the control button will switch on and you will hear a two-tone chime.
- You will hear the air pump removing the air from the Home Base - the vacuum process has started.
- During the vacuum process, the pump may switch to a higher pump level up to two times. You will hear a slightly louder and higher pump sound. This is normal for the operation of the pump and does not affect the lifetime of the Vacuvita Home Base.
- After max. 90 seconds (depending on the fill level) the Home Base will reach its vacuum level and the pump will switch off automatically.
- Just as your refrigerator checks and adjusts its temperature when operating, the Vacuvita Home Base checks its vacuum level at regular intervals. At those intervals the pump will switch on to maintain the vacuum level in the Home Base.
- To open your Home Base again, just press the easy access control button. This may be done at any time while it is operating.

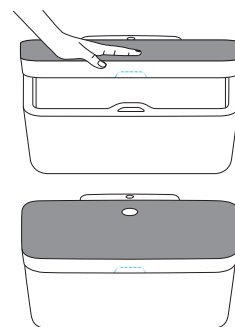

Tips & Tricks

Emergency vacuum release



Warning: In case of emergency, always remove the power plug from the wall socket.

In case of an emergency or system malfunction, the vacuum can be released by pressing the emergency vacuum release switch.

- Turn the Vacuvita Home Base, so the back is facing you.
- Using a thin product, such as a skewer, paperclip or needle, gently press the switch located behind the little hole in the Home Base housing.
- You will immediately hear the sound of vacuum being released.
- Keep the switch pressed until the sound has stopped
- Open the Home Base lid by pressing the button in the front, or open the lid manually.
- The Home Base is ready for normal use again.

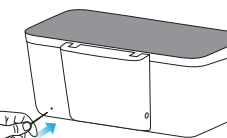
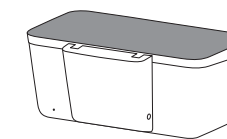

Standby mode

If the sealing is compromised, a vacuum cannot be created, or when there is no need or desire for vacuum storage, the Vacuvita Home Base has a standby mode. This standby mode allows the Home Base to open and close, but does not switch on the pump to create a vacuum.

- Close the Vacuvita Home Base lid.
- Place your hand on the lid as shown — there is no need to wait for the vacuum to be completed. Press down firmly.
- After five seconds, the blue indicator light on the front of the Home Base will begin to blink. Keeping your hand on the lid, press the control button on the front of the Home Base with your other hand.
- The blue indicator light will switch off; this means the standby mode is activated.
- If present, any vacuum will be released from the Home Base and the lid will open.
- Open and close the Home Base in the usual way. The blue indicator light and pump will not switch on when the Home Base is closed in standby mode.
- To switch off the standby mode, simply place your hand on the lid again and press. After five seconds, the blue indicator light will switch back on and blink.
- Keeping your hand on the lid, press the button on the front of the Home Base control button on the front of the Home Base with your other hand.

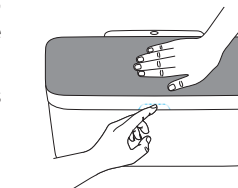
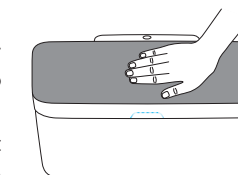

Vacuvida Vacuum adapter

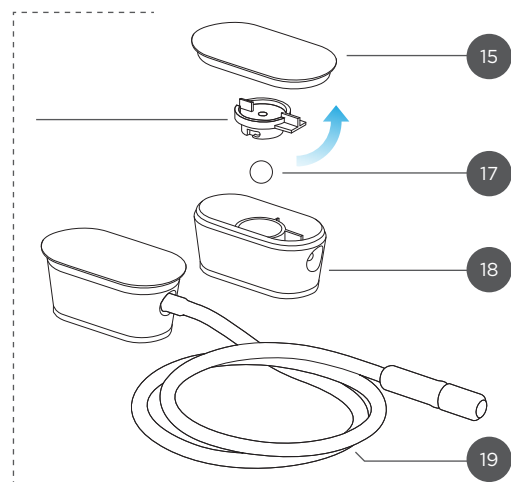

- 14. Vacuum adapter
- 15. Detachable adapter lid
- 16. Adapter channel
- 17. Adapter ball
- 18. Adapter housing
- 19. Tube

Vacuvida Vacuum bags

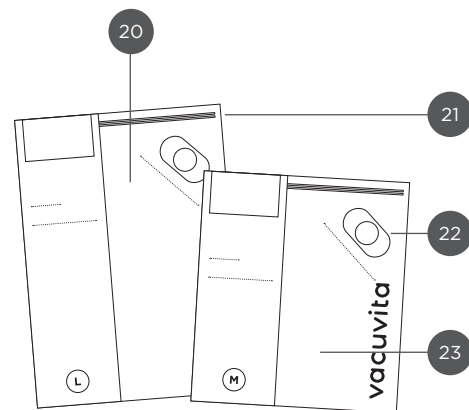

- 20. 5 x Vacuvida bags; large
- 21. Re-sealable zip
- 22. Vacuum bag valve
- 23. 5 x Vacuvida bags; medium

Using the Vacuvida Home Base with vacuum bags

- Use only Vacuvida vacuum bags. They are designed to be used with the Vacuvida high-performance vacuum system.
- Place your food item inside the bag. Always allow food to cool to room temperature before applying vacuum.
- Do not fill the bags beyond the maximum fill line, as food or liquids may be pulled into the vacuum adapter.
- Firmly press to close the zip completely.
- Place the bag on a flat surface, with the valve facing up.
- Remove the cap from the adapter socket behind the Home Base lid. Insert the free side of the adapter hose into the vacuum socket.
- The LED light rings will switch on, below the Home Base lid.
- Place the vacuum adapter on the marked area around the valve of the vacuum bag. Gently press it down.
- Press the capacitive touch control (the middle of the area lit up by the LED light rings on the Home Base) to activate the vacuum process.

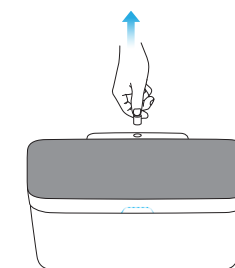
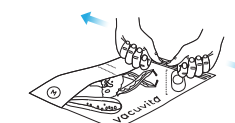
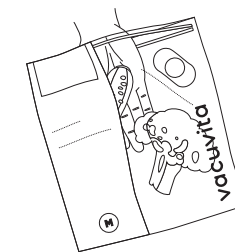

- Hold down the adaptor on the vacuum bag. The system will automatically switch off when it reaches the right vacuum level. Alternatively, you can stop the vacuum process manually by pressing the capacitive touch control.
- If there is still a lot of air inside the vacuum bag when it switches off, make sure the valve is not blocked by any food in the bag and repeat until the right result has been obtained.
- Remove the adapter from the vacuum bag and disconnect the tube from the Home Base.
- If you wish, you can write down the date and contents of the bag in the designated area.
- Store your bag in a place that is appropriate to your food type and your intended preservation period (see also chapter 'Storage chart', page 26).

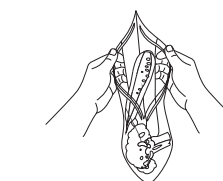
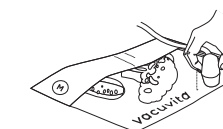
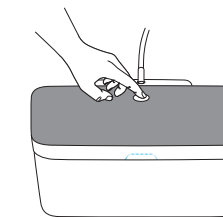

Sharp edges

When vacuum packaging items with sharp edges (e.g. dried pasta or skewered products) in Vacuvita bags, protect the bag from punctures by wrapping items in soft cushioning material, such as a paper towel. You may want to use a Vacuvita container instead of a bag.

Interruption Homebase

To open your Homebase again, just press the easy access control button. This may be done at any time while it is operating.

Heat cooked foods

Always allow food to cool to room temperature before applying the vacuum

- To open, firmly grasp two sides of the bag near the zip and gently pull them apart.
- The bags are suitable for repeated use; just take out a portion of the contents and reseal as described above.



The bags are not intended to be cleaned. Do not use the bags for different (raw) products after each other. Always apply proper hygienic precautions to prevent foodborne illness.

- For an optimal vacuum process with liquids (such as freshly-made soup) we recommend placing the liquid in a bowl in the freezer for a few hours. Whenever possible, we recommend using our containers to store liquids. When the liquid has frozen, the vacuum process is the same as that with solid food.
- To store juicy, moist or marinated food, hang the vacuum bag from your kitchen worktop, keeping the valve flat on the surface. This will prevent the liquid from running into the valve and blocking the airflow.
- If liquids do enter the vacuum adapter the process will switch off automatically. Remove the adapter from the bag, clean it as described below and restart the process.

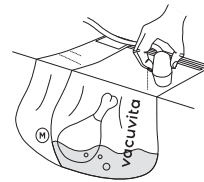

Vacuvita Container

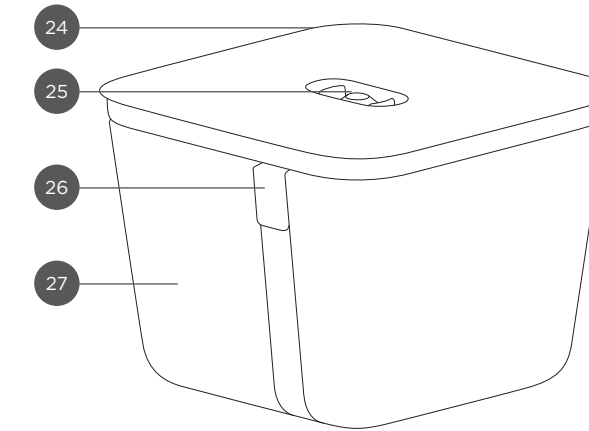

- 24. Container lid
- 25. Valve; socket for the vacuum adapter
- 26. QR tag
- 27. Container base with window

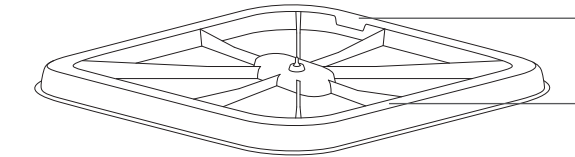

- 28. Recess for peeling seal from the lid
- 29. Seal inside the lid

Using the Vacuvita Home Base with vacuum containers

- Carefully follow the instructions on page 15 'Using your Vacuvita Home Base' to ensure safe use of the device.
- Place your food inside the container.



Always allow food to cool to room temperature before applying the vacuum.

- Do not fill the container beyond the max fill line, as food or liquids may be pulled into the vacuum adapter.
- Ensure that the seal in the lid and the rim of the container are clean and dry. Liquids and little pieces of food on the seal or the rim may prevent the container from reaching the appropriate vacuum level or cause leakage.
- Put the lid on the container and press firmly to close.
- Remove the cap from the adapter socket behind the Home Base lid. Insert the free side of the adapter hose into the vacuum socket.

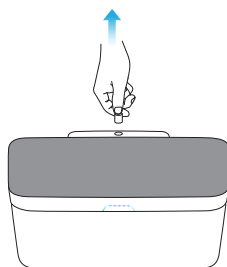

- The LED light rings will switch on below the Home Base lid.
- Place the vacuum adapter on the valve and gently press it down.
- Press the capacitive touch control (the middle of the area lit up by the circular indicator light) to activate the vacuum process.
- Hold down the adaptor on the valve of the container. The system will automatically switch off when it reaches the right vacuum level.
- To open the container, release the vacuum by gently pulling up one of the flaps of the valve. You will hear a hissing noise that indicates that the air is now entering the container. When the hissing noise stops, open the lid as usual.

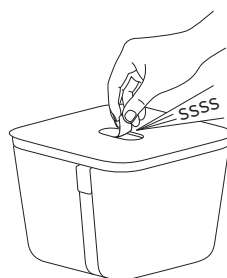
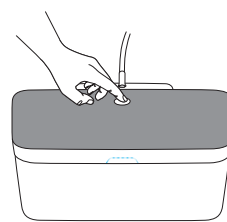
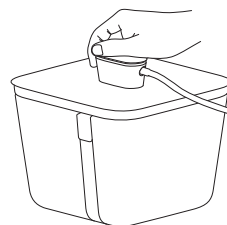

Microwave use

- Never use empty Vacuvita containers in the microwave. Never microwave the containers with the lid on to allow hot air to escape and prevent ruptures, damage to the container or injuries from exposure.
- You can heat cooked foods, such as leftovers, in a Vacuvita bag using a microwave. The bag should not be used to microwave raw foods. Always open the bag prior to putting it in a microwave to let the steam escape. Avoid microwaving foods containing oil, as it will get hot very quickly and could cause the side of the bag to stick together. Vacuvita vacuum bags cannot be re-used or re-sealed after being used in a microwave.

How to scan your containers: Using the QR code

All Vacuvita containers are equipped with a tag bearing a QR code. This helps you to easily identify the container and its contents, even if you have several containers in use.



You need the Vacuvita app to use the QR code - see Vacuvita.com/mobile/app for more information.

With the Vacuvita app, you can create an overview of the food stored in your freezer, pantry or refrigerator. The app will notify you when food is close to expiry so that it can be consumed while it is still safe, helping you to reduce waste and save money.

- After packing your Vacuvita container and completing the vacuuming process, scan the QR code, following the instructions on your mobile phone screen.
- The Vacuvita app will instruct you to fill in information such as the type of food in the container and where it will be stored (pantry, freezer or refrigerator).
- Place the container in the appropriate storage location.
- The app has added the container and its contents to the list of different foods that you have stored.
- If you have stored multiple containers in the same location (e.g. freezer), you can easily scan the QR code on the tags with the app to see what is inside.
- Next to the QR code, each tag also bears an alphanumeric code. The app displays this code in the list of stored food so that you can also find the container you are looking for without using the scanning function.

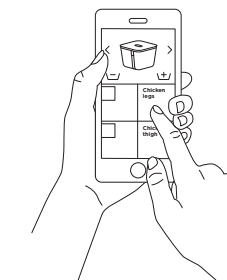
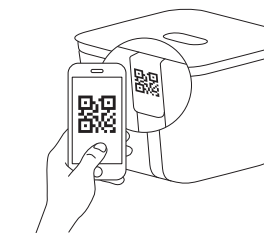

Cleaning

Cleaning the Home Base

- Open the Vacuvita Home Base by pressing the control button on the front.
- To protect against the risk of electric shock, cut the electric power by removing the plug from the power outlet.
- Clean both the outside and the inside of the Home Base using a sponge or cloth with water and mild soap.
Be careful not to flood the vacuum socket or air filter with water! Do not use the inside of the Home Base as a bowl for washing up. Do not submerge the Home Base in water!
- If required, the lid seal can be removed for cleaning. Gently pull it from the inside of the lid and use water and a mild soap.

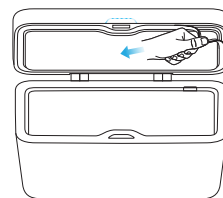
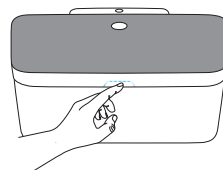

Do not put the seal in the dishwasher.
Do not use sharp objects to remove or reinstall the seal.

- To re-install the seal, make sure it is positioned properly, with the solid section facing towards the inside and the two thinner flaps facing outside the Home Base.

- Gently press the seal in the groove, by first positioning the seal at the four corners and then pressing it down in the straight sections
- Be sure to press along the entire length of the seal, so that it is properly positioned and distributed evenly along the groove. Make sure not to stretch the seal during application.

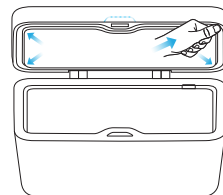

Cleaning the dust and particle filter

During the vacuum process small crumbs or food particles may be sucked into the vacuum system. It is recommended that you regularly clean the filter on the Home Base.

- Place your finger in the slot on the filter.
- Simply pull the filter upward, sliding it out of the wall. Do not pull it towards you!
- Gently tap the crumbs and particles out of the filter.
- If the filter cannot be cleaned, replace it with an original Vacuvita part. Visit vacuvita.com for details.
- Gently slide the filter back after cleaning.

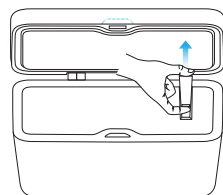

Cleaning or replacing the removable air filter

- Occasionally, you may need to clean or replace the air filter on the outside of the Home Base. It is recommended to clean the filter once every year, or when the pump sound is clearly louder and the vacuum process takes longer than prior.
- Remove the power plug from the wall socket. Place a soft cloth or towel in front of the Home Base.
- Gently tilt the Home Base forward, until the front touches the cloth. Do not drop the Home Base, as this may result in damage or malfunction!

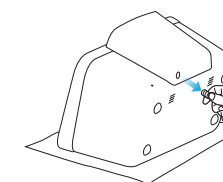
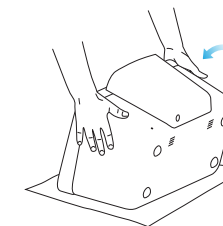

If the filter cannot be cleaned, replace it with an original Vacuvita part. Visit www.vacuvita.com for details.

- Pull the filter from the bottom of the Home Base to clean it.
- Clean the filter by gently tapping it on a hard surface or use the corner of a clean cloth to remove dust and particles.
- After cleaning, push the filter back in place.
- Return the Home Base to its upright position and put the plug back into the wall socket.

Cleaning the vacuum adapter

- Disconnect the adapter tube from the Vacuvita Home Base.
- Remove the lid from the adapter.
- Turn the adapter channel counterclockwise and lift it from the inside of the housing.
- Remove the ball.
- The parts may be cleaned using water and mild soap.

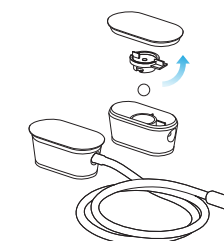

Do not scrub the sealing surfaces using scouring materials as this may damage the sealing and cause malfunctions. Make sure all the parts are dried properly before use, especially the inside cavities of the adapter housing.

Cleaning the vacuum tube

The tube is not intended for cleaning as fluids are not supposed to enter the system. If, by unforeseen circumstances, fluids have entered the tube and you do wish to attempt cleaning it, the tube can be rinsed by submerging in warm water or holding it under the tap. After rinsing make sure that all water is out of the tube, before using it again. If there is a lot of water left in the tube, gently blowing on one end might help.

Cleaning the container

- Wash the container and the lid by using water and mild dishwasher soap.
- The base of the container is top-rack dishwasher safe. The lid should only be cleaned manually to avoid damage.



Do not scrub the seal or the valve using scouring materials as this may damage it and prevent the container from sealing

- Thoroughly dry the container and the lid before using it again.

Cleaning and re-installing the seal

- Flip the lid upside down. You will notice a small recess on the inner rim. Place your finger in the indent and gently pull out the seal.
- Clean the seal using water and a mild soap.

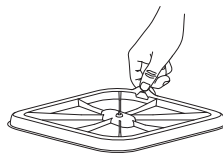

Do not put the seal in the dishwasher.
Do not use sharp objects to remove or reinstall the seal.

- Wipe the seal dry before re-installing it in the lid.
- To re-install the seal, locate the flat side of the seal. Keeping the seal flat side down, start by placing it one of the corners and pressing it down, working your way along the sides.

Cleaning the valve

- Grab the valve on top of the container by the flaps and pull it out of the lid.
- Clean the valve using water and mild soap.
- To re-install the valve, place it in the middle of the lid, aligning it to the indent. The nipple of the valve should go through the hole. Grab the nipple from the other side of the lid and pull it gently to secure it in place.

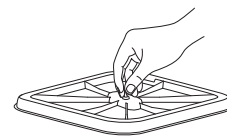
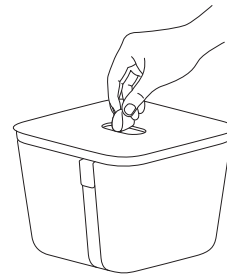

Troubleshooting

When the Home Base is unable to achieve the required vacuum level, either in the Home Base itself, the bags or the containers, one of the following light indicators codes may appear:

Lights are blinking		This means:	Possible solutions:
Inner LED light ring + Blue indicator light		The proper vacuum level in the Home Base cannot be reached. The system has automatically switched off.	<ul style="list-style-type: none"> • Check if there are any items sticking out of the Home Base that might prevent the lid from closing completely. • Check if there is anything crossing the seal. • If so, remove the items and try the process again.
Middle LED light ring + Blue indicator light		It takes too long for the proper vacuum level in the Home Base to be reached. The system has automatically switched off.	<ul style="list-style-type: none"> • Remove the lid seal and carefully clean it. • Closely inspect the seal for small damages, holes or ruptures. • If the seal is intact and clean, re-install it and try the system again.
Outer and inner LED light ring + Blue indicator light		The proper vacuum level in the container or bag cannot be reached. The system has automatically switched off.	<ul style="list-style-type: none"> • Check all connections between the Home Base and the container or bag. • Check if there are any items sticking out of the container that might prevent the lid from closing completely. • Check if there is anything crossing the seal. • Firmly press the lid back on the container and try again.
Outer and middle LED light ring + Blue indicator light		It takes too long for the proper vacuum level in the container or bag to be reached. The system has automatically switched off.	<ul style="list-style-type: none"> • Remove the container seal and carefully clean it. • Closely inspect the container seal for small damages, holes or ruptures. • If the seal is intact and clean, re-install it and try the system again. • Check the seal on the bag to see if it is properly closed. • Check if there are no holes or tears in the bag.
Pump does not switch on + Light does not switch on		There is no electrical connection between the lid magnet and steel plate on the Home Base. The system did not switch on.	<ul style="list-style-type: none"> • Make sure the Home Base is properly connected to a power outlet. • Remove any items that might prevent the lid to close completely. • Clean the magnet on the lid and the steel plate on the Home Base. • Make sure the Home Base is not in standby mode. See page 18 for instructions regarding starting and stopping the standby mode.

In case the suggested tips do not help or the problem persists, please visit www.vacuvita.com or email us at service@vacuvita.com.

Warranty

1 year Limited Warranty

Vacuvida B.V. (“Vacuvida”) warrants that from the date of purchase, this product will be free from defects in material and workmanship provided this product is used strictly as described in this user manual, using only original Vacuvida parts and accessories. This limited one year warranty shall be effective from the date of the original purchase and shall expire one (1) year after the original purchase date (“Limited Warranty Period”). Vacuvida, at its option, will repair or replace this product or any component of the product found to be defective during the Limited Warranty Period, provided the defect is not caused by the use of any non-Vacuvida branded part or accessory or has not been tampered with by others than Vacuvida personnel or service agents. A replacement will be made with a new or refitted product or component. If the product is no longer available, a replacement may be made with a similar product of equal or greater value. This is your exclusive Limited Warranty. Do NOT attempt to repair or adjust any electrical or mechanical functions on this product. Doing so will void this Limited Warranty. This Limited Warranty applies only to the original purchaser of the product and only from the date of initial retail purchase as per the original sales receipt and is not transferable. Proof of purchase is required to obtain warranty performance.

Vacuvida dealers, service centers, or retail stores selling Vacuvida products do not have the right to alter, modify or in any way change the terms and conditions of this Limited Warranty. This Limited Warranty does not cover ordinary wear and tear of parts or damage resulting from any of

the following: negligent use or misuse of the product, use on improper voltage or current, use contrary to the operating instructions or this DFU, disassembly, repair or alteration by anyone other than Vacuvida or an authorized Vacuvida service center, or use of this product with non-Vacuvida parts or accessories. Furthermore, this Limited Warranty does not cover Acts of God such as fire, flood, hurricanes and tornadoes. This Limited Warranty shall not be deemed to exclude or replace any warranties set by law. Apart from the specific legal rights conferred to you in this Limited Warranty, you may have other rights which vary from jurisdiction to jurisdiction.

What are the limits of Vacuvida’s liability?

Damage to a product caused by use of non-Vacuvida parts or accessories, accident, misuse, or abuse is not covered by this Limited Warranty. Improper care and cleaning will void this Limited Warranty. Vacuvida shall not be liable for any indirect, incidental or consequential damages caused by the breach of any express, implied or statutory warranty or condition. Except to the extent prohibited by applicable law, Vacuvida disclaims all warranties, conditions or representations, express, implied, statutory or otherwise. Vacuvida does not claim the product to be fit for a particular purpose. Vacuvida shall not be liable for any damages of any kind resulting from the purchase, use or misuse of, or inability to use the product including indirect, incidental, special, consequential or similar damages or loss of profits, or for any breach of contract, fundamental or otherwise, or for any claim brought against purchaser by any other

party. Some provinces, states or jurisdictions do not allow the exclusion or limitation of incidental or consequential damages or limitations on how long an implied warranty lasts, so the above limitations or exclusions may not apply to you. This warranty gives you specific legal rights, and you may also have other rights that vary from province to province, state to state or jurisdiction to jurisdiction.

How to Obtain Warranty Service

In the U.S.A.

If you have any question regarding this warranty or would like to obtain warranty service, please visit www.vacuvida.com or email us at service@vacuvida.com.

In the U.S.A., this warranty is offered by:

Vacuvida B.V.
Orionstraat 15
2516 AS The Hague
The Netherlands

PLEASE DO NOT RETURN YOUR PRODUCT TO THIS ADDRESS.

BO 4316

Check latest version of manual and product updates online at www.vacuvida.com

vacuvita®

Designed to suit your taste



Vacuvita B.V.
Orionstraat 15, 2516 AS The Hague, The Netherlands

www.vacuvita.com