

HUMMINGBIRD

Mini Drone with Cage



User's Guide for Model DR118 v2163-01



Warnings & Precautions

Important Safety Instructions

- Read and follow all instructions.
- Keep these instructions for future reference.
- Heed all Warnings.
- Intended for children ages 14 and higher. Adult supervision is required.
- Only use attachments/accessories specified by the manufacturer.
- Before flying, always check the body, rotors, and battery for any damage or obstructions.
- Battery should be free from cracks or swelling.
- Keep the rotors clear of any obstructions and body parts to avoid potential damage and injury.
- Manufacturer and dealer assume no liability for accidental damages from improper use or installation of parts, or from damage incurred from worn or broken parts.
- Pilots are responsible for their actions and any damage caused from improper use.
- Pilots should keep the craft in sight at all times during flight. If you lose sight of the craft at any time, power down and cease flight immediately.
- Only fly in large, open areas that are free from obstacles or potential hazards, such as trees, power lines, ceiling fans, and the like.

- Flying over bodies of water is not recommended.
- Flying at night is not recommended.
- Never try to retrieve the craft from areas you cannot safely reach, such as rooftops or trees.
- Never launch the craft from your hand.
- Never leave the craft unattended while it is powered on or while the battery is charging.

FCC Warnings

Warning: Changes or modifications to this unit not expressly approved by the party responsible for compliance could void the user's authority to operate the equipment.

NOTE: This equipment has been tested and found to comply with the limits for a Class B digital device, pursuant to Part 15 of the FCC Rules. These limits are designed to provide reasonable protection against harmful interference in a residential installation. This equipment generates, uses, and can radiate radio frequency energy and, if not installed and used in accordance with the instructions, may cause harmful interference to radio communications. However, there is no guarantee that interference will not occur in a particular installation. If this equipment does cause harmful interference to radio or television reception, which can be determined by

Warnings & Precautions

turning the equipment off and on, the user is encouraged to try to correct the interference by one or more of the following measures:

- Reorient or relocate the receiving antenna.
- Increase the separation between the equipment and receiver.
- Connect the equipment into an outlet on a circuit different from that to which the receiver is connected.
- Consult the dealer or an experienced radio/TV technician for help.

Additional Warnings & Precautions

- **WARNING:** To reduce the risk of fire or electric shock, do not expose this apparatus to rain, moisture, dripping, or splashing.
- **CAUTION:** Use of controls or adjustments or performance of procedures other than those specified may result in personal injury.
- **WARNING:** Changes or modifications to this unit not expressly approved by the party responsible for compliance could void the user's authority to operate the equipment.
- **CAUTION:** Danger of explosion if battery is incorrectly replaced. Replace only with the same or equivalent type.

- Lithium batteries, like all rechargeable batteries, are recyclable and should be recycled or disposed of according to state and local guidelines. They should never be disposed of in normal household waste, and they should never be incinerated, as they might explode. Contact your local government for disposal or recycling practices in your area.
- **WARNING:** Shock hazard - Do Not Open.
- Battery shall not be exposed to excessive heat such as sunshine, fire, or the like.
- Keep new and used batteries away from children. If the battery compartment does not close securely, stop using the product and keep it away from children.
- If you think batteries might have been swallowed or placed inside any part of the body, seek immediate medical attention.
- Do not mix old and new batteries.
- Completely replace all old batteries with new ones.
- Do not mix alkaline, standard (carbon-zinc), or rechargeable (ni-cad, ni-mh, etc) batteries.
- Batteries should be recycled or disposed of as per state and local guidelines.
- Only use the included power supply/power charger or a UL/ETL certified power supply of the same power output specifications.

Table of Contents

Mini Glow Quadcopter Drone

Features–6

Includes–6

Overview

Features & Layout–7

Remote Control

Functions–8

Battery Installation–10

Charging the Battery

Battery Charging Procedure–12

Flying

Remote Link & Gyro Calibration–14

Setting Trim & Countering Drift–16

Gyroscope Recalibration & Trim Reset–19

Tips for Safe Operation–20

Speed Setting–21

Headless Mode–22

Flips–23

Parts & Repair

Rotor Replacement–24

Parts Replacement –26

Troubleshooting

Troubleshooting Guide–27

Customer Support

Contact Information–30

International Support–30

Warranty–30

Mini Glow Quadcopter Drone

Features

- 360° flips & tricks
- 6-axis gyroscope
- 3 speed settings
- Control distance: up to 98 ft.
- Headless Mode
- LED navigation lights
- Built-in, rechargeable lithium-polymer battery power
- Operating time: 5-6 minutes
- Charge time: 30 minutes

Includes

- 2.4 GHz remote control: requires 2 AAA batteries (not included)
- USB cable for battery recharge
- 4 x replacement rotors
- Screwdriver
- User's guide

Overview

Features & Layout

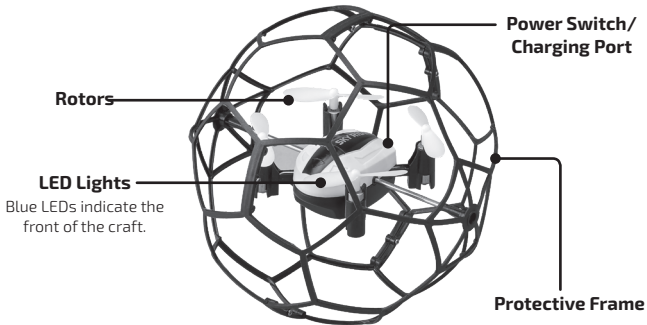

Remote Control

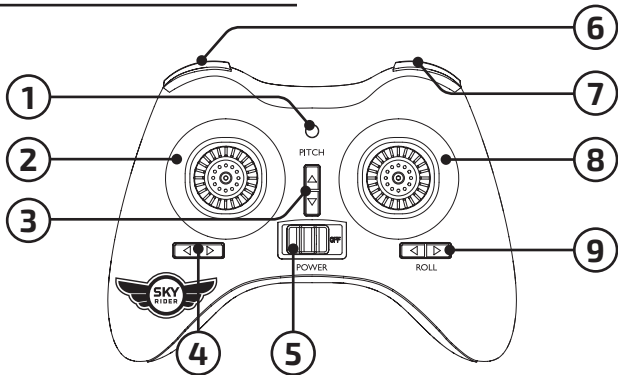

Functions

1. Power Indicator Light
2. Left Stick Functions
 - Increase/Decrease Power: move forward/backward
 - Yaw (Spin): move left/right
 - Press to change speed setting (low/med/high)
3. Pitch Trim Adjustment
4. N/A
5. Power Switch
6. Headless Mode
7. Trim Reset
8. Right Stick Functions
 - Pitch: move forward/backward
 - Roll: move left/right
 - Press and move stick in any direction to flip.
9. Roll Trim Adjustment

Remote Control

Battery Installation

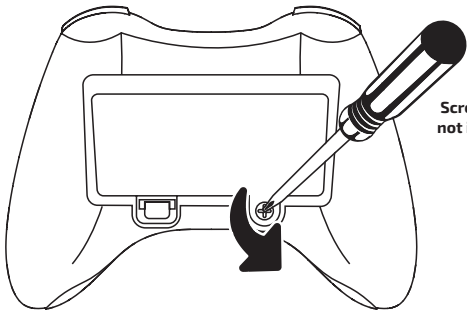

**Screwdriver
not included.**

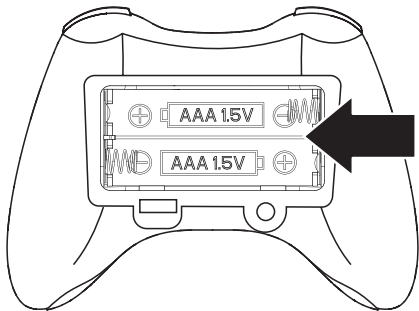

**Insert 2 x AAA batteries
(not included).**

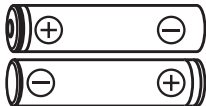

Charging the Battery

Battery Charging Procedure

The craft's battery must be charged before it can be flown. **Before charging, be sure the craft and remote control are powered OFF** to avoid risk of injury or damage.

Connect the charging cable (included) to the USB port of a powered ON computer or USB power adapter (not included), then connect the charging plug to the unit. **Be sure to correctly match the plug to the charging port or damage may occur.** Charge fully before use for maximum performance and flight time. Charging time is approximately 40-50 min.

While charging, the cable will display a red light.

When charging is complete, the light will turn OFF.

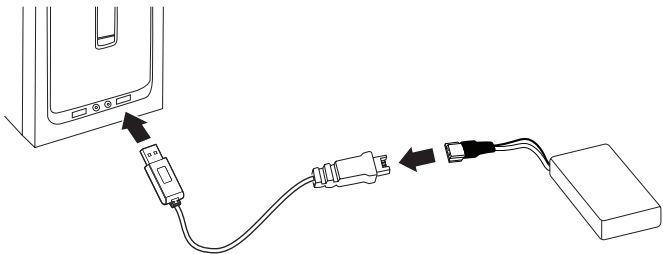

REMINDER: Do not charge overnight. Do not leave unattended while charging.

Flying

Remote Link & Gyro Calibration

Before flying, the craft and the remote must be linked together and the gyroscopes on the craft must be allowed to calibrate.

Tips before getting started:

- **Begin with the craft and remote powered OFF.**
- **Be sure the craft and you are facing the same forward direction.**
- **Rotate the protective frame to find the position in which the craft is most level.**
- **If necessary, gently squeeze the axle from the outside of the protective frame and reposition the craft.**
- **Once the craft is flying, refer to the Setting Trim section (pg. 16) to fine-tune flight calibration.**

Step 1

Power ON the craft and place it on a flat surface. This is necessary for the craft's gyroscopes to properly align. The lights on the craft will blink as it searches for a signal from the remote.

Step 2

Power ON the remote. The light on the remote will blink as it searches for the signal from the craft. An audible chime will sound and all lights will turn solid when the remote and the craft have linked.

Step 3

Push the **Left Control Stick (throttle)** fully forward and backward, and wait for a second chime. **When this last chime has sounded the craft is ready to fly.**

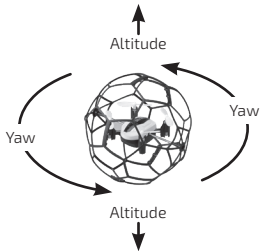

Left Stick controls Altitude (power) and Yaw (spin).

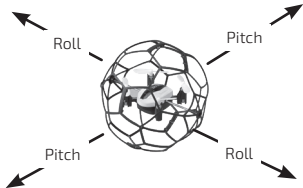

Right Stick controls Pitch (forward/backward) and Roll (left/right).

Flying

Setting Trim & Countering Drift

Even after the craft is calibrated, it may show a tendency to drift while airborne. Adjusting the trim will help counter this effect and allow for better control the craft.

- To avoid potential damage, adjust the trim while attempting a stable hover.
- Try to avoid making any exaggerated movements with the flight controls.
- Adjust one trim setting at a time to avoid confusion.

Remember, the blue LED lights indicate the front of the craft.

Adjusting the trim will help with drift but it will not entirely eliminate it. Turbulence and other factors may still influence the craft's flight characteristics.



Craft drifts right or left.

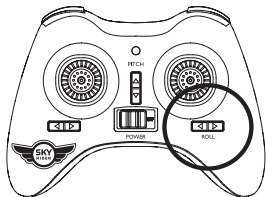

Adjust **Roll Trim**.

Flying



Craft drifts forward or backward.

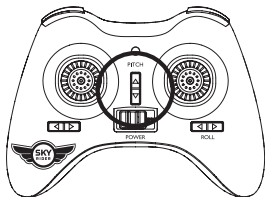

Adjust **Pitch Trim**.

Gyroscope Recalibration & Trim Reset

If the craft is experiencing difficulty flying or is behaving erratically, the gyroscopes may need to be recalibrated. It may also help to reset the trim settings for the remote. Do not attempt to do this while flying, safely land the craft first and place it on a flat surface. The craft and the remote should already be linked together.

To reset the gyroscopes on the drone, pull down and to the right on **both control sticks** for 2-3 seconds. The LED lights on the drone will blink during the recalibration. When the LED lights have stopped blinking and return to solid the recalibration is complete and the craft is ready to fly.

To reset the trim adjustments on the remote, press the **Right Control Stick** and hold it for 3 seconds. The remote will chime once when the reset is complete.

Flying

Tips for Safe Operation

- It is recommended to only fly in large, open spaces that are free of obstacles like power lines, trees, ceiling fans, etc.
- When flying indoors avoid walls and ceilings, as the craft may be drawn towards them if closer than 2-3 feet.
- Stand behind the craft when first taking off, so that you and the craft are facing the same "forward" direction. This will help with orientation when the craft is airborne.
- Novice pilots should move the controls slowly and deliberately to get used to the craft's flying characteristics. Try using one control at a time.
- Practice basic flight operations like take off, hovering, and landing.
- If you get into trouble or if anything obstructs the rotors, cut power immediately and safely clear the obstruction. Check for possible damage before flying again.

Speed Setting

Press the **Left Control Stick** on the remote to change the craft's speed setting.

- **Low:** Provides smooth and predictable control of the craft. The remote will chime once to indicate the low speed setting.
- **Medium:** The craft will move and respond faster to all control inputs. The remote will chime twice to indicate the medium speed setting.
- **High:** Highest setting for maximum performance. The remote will chime three times to indicate the high speed setting.

Flying

Headless Mode

Before using Headless Mode be sure you and the craft are facing the same "forward" direction, otherwise the craft will not fly correctly. **To activate Headless Mode, press the Left Trigger** on the remote control. The LED lights will quickly flash while Headless Mode is ON. Press again to deactivate Headless Mode.

While Headless Mode is active the craft will fly in whatever direction the **Right Control Stick** is moved, regardless of where the front of the craft is pointing. For example, if the front of the craft was pointed straight ahead but is now pointed right 90°, when you push forward on the stick the craft will fly forwards as if it was still pointed straight ahead. This can be useful if you become disoriented while flying and cannot visually determine which direction the craft is facing.

Flips

Before attempting a flip, be sure that there is ample clear space around the craft, ideally 9-10 ft.. in all directions. It is not recommended to attempt to flip around or through any obstacles, as this may result in unintended damage.

Press the **Right Control Stick once**, then move it in any direction and the craft will perform a flip in the same direction.

Parts & Repair

Rotor Replacement

The craft comes with replacement rotors if the originals become broken or badly damaged. To replace a rotor, pull it upwards and off of the motor shaft, then place the new rotor on the shaft and gently push down. Take special care not to bend or break the motor shaft. If the rotors are difficult to remove by hand, try a small set of tweezers or pliers.

It is extremely important to use the correct rotor for replacement. Using the incorrect rotor will make the craft impossible to control. The marking can be seen on the rotor near the center.

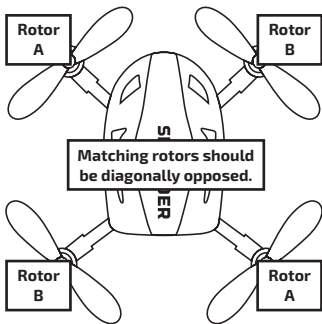

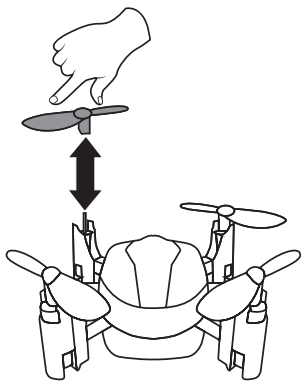

Parts & Repair

REMINDER: Pilots are responsible for any damage caused by improper use.

Parts Replacement

Standard parts such as extra batteries and remotes are available online for purchase when in stock. However, any non-standard parts such as cameras, screws, bodies, SD cards etc. can be ordered by placing an inquiry with our parts department at: **partsinfo@dpiinc.com**.

Troubleshooting

Troubleshooting Guide

PROBLEM	POSSIBLE CAUSES	SOLUTION
Craft does not respond to controls.	<ul style="list-style-type: none">• No power to remote or craft.• Poor contact between power plugs.• Craft is out of range.	<ul style="list-style-type: none">• Check remote batteries, replace if needed.• Check craft battery, be sure it is fully charged.• Be sure the power plugs are firmly connected.• Be sure the remote has an unobstructed line of sight to the craft.• Remain within the remote's 98 ft. range.

Troubleshooting

PROBLEM	POSSIBLE CAUSES	SOLUTION
Craft is difficult to control or flies erratically.	<ul style="list-style-type: none">• Gyroscopes may be misaligned.	<ul style="list-style-type: none">• Recalibrate gyroscopes (see pg. 19).• Power OFF remote and craft and reconnect (see pg. 14).
Craft drifts while in flight.	<ul style="list-style-type: none">• Trim not set or needs adjustment.	<ul style="list-style-type: none">• Adjust trim settings (see pg. 16).• Reset trim settings (see pg. 19).
Craft suffers from mechanical trouble.	<ul style="list-style-type: none">• Damage to body, rotors or other major components.	<ul style="list-style-type: none">• Repair or replace parts as needed.

PROBLEM	POSSIBLE CAUSES	SOLUTION
LED lights ON but craft does not respond to controls.	<ul style="list-style-type: none">• Low battery power.	<ul style="list-style-type: none">• Recharge the battery.

Customer Support

Contact Information

Website: www.gpx.com

Email Support: prodinfo@dpiinc.com

Email Parts: partsinfo@dpiinc.com

Phone Support: **1-888-999-4215**

International Support

To download this User's Guide in English, Spanish, and French, or to get answers to frequently asked questions, visit the support section at: www.gpx.com

Para descargar este Manual del Usuario en inglés, español y francés, o para obtener respuestas a preguntas frecuentes, visite la sección de apoyo en: www.gpx.com

Pour télécharger ce guide de l'utilisateur en anglais, espagnol ou français, ou pour obtenir des réponses à des questions fréquemment posées, consultez la rubrique d'assistance sur: www.gpx.com

Warranty

See included 30 Day Warranty for warranty information. Warranty and the most up-to-date version of this User's Guide can also be found at: www.gpx.com



***Protect for Today
Sustain for Tomorrow***

Copyright © 2018 Digital Products International (DPI, Inc.)
All other trademarks appearing herein are the property of their respective owners.
Specifications are subject to change without notice.

