

The Airecoler logo features a stylized white wave icon to the left of the brand name. The wave is composed of three curved segments, with the top and bottom segments being white and the middle segment being light blue. The brand name "Airecoler" is written in a white, sans-serif font.

Airecoler

USER MANUAL

Stellar S10

Dear Valued Customer,

Welcome to the Airecoler family, where we're committed to delivering top-notch dehumidification solutions with exceptional customer support.

Whether you are dealing with excessive moisture, musty odors, or simply striving for a more pleasant living environment, our dehumidifier is here for help. This user manual and guide will ensure you understand Airecoler dehumidifier's functions and have access to ongoing support.

Post-Sales Support:

Our commitment to your satisfaction extends beyond the initial purchase. If you encounter any challenges or have questions regarding returns, damaged packages or replacements, our dedicated customer support team is ready to assist. Simply email us at service@airecoler.com with your purchase order ID, and we'll swiftly address your concerns.

Membership Perks:

Elevate your experience by registering as a member on Airecoler official website (www.airecoler.com) and unlock exclusive benefits, including priority customer support, special promotions and discounts, and valuable product updates and tips.

Best Regards,
The Airecoler Team

 Website: www.airecoler.com

 Email: service@airecoler.com

 Phone: [Available via our website](#)

 Live Chat: [Available via our website](#)

PRIOR TO FIRST USE

Please remove the dehumidifier from its packaging and allow it to stand upright for **24 hours** before plugging it in.

During normal shipping and handling, the dehumidifier may be positioned at various angles. Allowing the unit to stand upright for 24 hours helps ensure the compressor oil settles properly before operation, supporting optimal performance and long-term reliability. This waiting period is a standard recommendation for compressor-based appliances and helps ensure proper operation.

CONTENTS

WARNING FOR USING R32 REFRIGERANT	1
SAFETY PRECAUTIONS	12
PARTS IDENTIFICATION	13
INSTALLATION INSTRUCTIONS	14
1. Recommended Installations	14
2. Position Your Dehumidifier	14
3. Set up the Drainage System	15
OPERATION INSTRUCTIONS	15
1. Plug in the Electrical Cord	15
2. Control Panel Instruction	15
2.1 The Control Buttons	16
2.2 The LED Display	16
3. Operation the Dehumidifier	17
3.1 Turn on the dehumidifier	17
3.2 Check Room Humidity	17
3.3 Set Desired Humidity	17
3.4. Set Auto On/Off Timer	17
3.5. Turn the Dehumidifier off	18
4. Remote Controller Installation Instructions	18
SMART FUNCTIONS	19
1. Compressor 3-Minute Delay	19
2. Auto Defrost	19
3. Auto-Restart	19
CARE & MAINTENANCE	20
1. Cleaning the Dehumidifier	20
2. Cleaning the Air Filter	20
3. Storage Guidelines	20
TROUBLE SHOOTING GUIDE	21
WARRANTY	22

WARNING for Using R32 Refrigerant

Transportation, marking and storage for units that employ flammable refrigerants.

1. General

The following information is provided for units that employ FLAMMABLE REFRIGERANTS.

2. Transport of equipment containing flammable refrigerants

Attention is drawn to the fact that additional transportation regulations may exist with respect to equipment containing flammable gas. The maximum number of pieces of equipment or the configuration of the equipment permitted to be transported together will be determined by the applicable transport regulations.

3. Marking of equipment using signs

Signs for similar appliances used in a work area are generally addressed by local regulations and give the minimum requirements for the provision of safety and/or health signs for a work location. All required signs are to be maintained and employers should ensure that employees receive suitable and sufficient instruction and training on the meaning of appropriate safety signs and the actions that need to be taken in connection with these signs.

The effectiveness of signs should not be diminished by too many signs being placed together.

Any pictograms used should be as simple as possible and contain only essential details.

4. Disposal of equipment using flammable refrigerants

See national regulations.

5. Storage of equipment/appliances

The storage of the appliance should be in accordance with the applicable regulations or instructions, whichever is more stringent.

6. Storage of packed (unsold) equipment

Storage package protection should be constructed in such a way that mechanical damage to the equipment inside the package will not cause a leak of the REFRIGERANT CHARGE.

The maximum number of pieces of equipment permitted to be stored together will be determined by local regulations.

Requirements for operation, service and installation manuals of appliances using flammable refrigerants

WARNING

Do not use means to accelerate the defrosting process or to clean, other than those recommended by the manufacturer.

The appliance shall be stored in a room without continuously operating ignition sources (for example: open flames, an operating gas appliance or an operating electric heater.

Do not pierce or burn. Be aware that refrigerants may not contain an odour.)



**Refrigerant
Safety Group
A2L**

Qualification of workers

The manual shall contain specific information about the required qualification of the working personnel for maintenance, service and repair operations. Every working procedure that affects safety means shall only be carried out by competent persons.

Examples for such working procedures are:

- breaking into the refrigerating circuit;
- opening of sealed components;

Competence of service personnel

1. General

Information of procedures additional to usual information for refrigerating appliance installation, repair, maintenance and decommission procedures is required when an appliance with FLAMMABLE REFRIGERANT is affected.

The training of these procedures is carried out by national training organisations or manufacturers that are accredited to teach the relevant national competency standards that may be set in legislation.

The achieved competence should be documented by a certificate.

2. Information and training

- 2.1) The training should include the substance of the following.
- 2.2) Information about the explosion potential of FLAMMABLE REFRIGERANTS to show that flammables may be dangerous when handled without care.
- 2.3) Information about POTENTIAL IGNITION SOURCES, especially those that are not obvious, such as lighters, light switches, vacuum cleaners, electric heaters.
- 2.4) Information about the different safety concepts:
 - Unventilated-Safety of the appliance does not depend on ventilation of the housing.

- Switching off the appliance or opening of the housing has no significant effect on the safety.
 - Nevertheless, it is possible that leaking refrigerant may accumulate inside the enclosure and flammable atmosphere will be released when the enclosure is opened.
 - Ventilated enclosure-Safety of the appliance depends on ventilation of the housing.
 - Switching off the appliance or opening of the enclosure has a significant effect on the safety.
 - Care should be taken to ensure sufficient ventilation before.
 - Ventilated room -Safety of the appliance depends on the ventilation of the room.
 - Switching off the appliance or opening of the housing has no significant effect on the safety.
 - The ventilation of the room shall not be switched off during repair procedures.
- 2.5) Information about refrigerant detectors:
- Principle of function, including influences on the operation.
 - Procedures, how to repair, check or replace a refrigerant detector or parts of it in a safe way.
 - Procedures, how to disable a refrigerant detector in case of repair work on the refrigerant carrying parts.
- 2.6) Information about the concept of sealed components and sealed enclosures according to IEC60079-15:2010.
- 2.7) Information about the correct working procedures:
- a) Commissioning
- Ensure that the floor area is sufficient for the REFRIGERANT CHARGE or that the ventilation duct is assembled in a correct manner.
 - Connect the pipes and carry out a leak test before charging with refrigerant.
 - Check safety equipment before putting into service.
- b) Maintenance
- Portable equipment shall be repaired outside or in a workshop specially equipped for servicing units with FLAMMABLE REFRIGERANTS.
 - Ensure sufficient ventilation at the repair place.
 - Be aware that malfunction of the equipment may be caused by refrigerant loss and a refrigerant leak is possible.
 - Discharge capacitors in a way that won't cause any spark. The standard procedure to short circuit the capacitor terminals usually creates sparks.
 - Reassemble sealed enclosures accurately. If seals are worn, replace them.
 - Check safety equipment before putting into service.
- c) Repair
- Portable equipment shall be repaired outside or in a workshop specially equipped for servicing units with FLAMMABLE REFRIGERANTS.
 - Ensure sufficient ventilation at the repair place.
 - Be aware that malfunction of the equipment may be caused by refrigerant loss and a refrigerant leak is possible.
 - Discharge capacitors in a way that won't cause any spark.

When brazing is required, the following procedures shall be carried out in the following order:

- Safely remove the refrigerant following local and national regulations. If the recovery is not required by national regulations, drain the refrigerant to the outside. Take care that the drained refrigerant will not cause any danger. In doubt, one person should guard the outlet. Take special care that drained refrigerant will not float back into the building;
- Purge the refrigerant circuit with oxygen free nitrogen;
- Evacuate the refrigerant circuit;
- Purge the refrigerant circuit with nitrogen for 5 min (not required for A2L refrigerants).
- Evacuate again(not required for A2L refrigerants).
- Remove parts to be replaced by cutting or brazing.
- Purge the braze point with nitrogen during the brazing procedure required for repair.
- Carry out a leak test before charging with refrigerant.
- Reassemble sealed enclosures accurately. If seals are worn, replace them.
- Check safety equipment before putting into service.
- Reassemble sealed enclosures accurately. If seals are worn, replace them.
- Check safety equipment before putting into service.

d) Disposal

- Ensure sufficient ventilation at the working place.
- Remove the refrigerant. If the recovery is not required by national regulations, drain the refrigerant to the outside. Take care that the drained refrigerant will not cause any danger. In doubt, one person should guard the outlet. Take special care that drained refrigerant will not float back into the building.
- When flammable refrigerants are used,
 - evacuate the refrigerant circuit.
 - purge the refrigerant circuit with oxygen free nitrogen.
 - evacuate again. (not required for A2L refrigerants);
 - cut out the compressor and drain the oil.

Information on servicing

1. General

The manual shall contain specific information for service personnel according.

2. Checks to the area

Prior to beginning work on systems containing FLAMMABLE REFRIGERANTS, safety checks are necessary to ensure that the risk of ignition is minimised.

For repair to the REFRIGERATING SYSTEM.

3. Work procedure

Work shall be undertaken under a controlled procedure so as to minimise the risk of a flammable gas or vapour being present while the work is being performed.

4. General work area

All maintenance staff and others working in the local area shall be instructed on the nature of work being carried out. Work in confined spaces shall be avoided.

5. Checking for presence of refrigerant

The area shall be checked with an appropriate refrigerant detector prior to and during work, to ensure the technician is aware of potentially toxic or flammable atmospheres. Ensure that the leak detection equipment being used is suitable for use with all applicable refrigerants, i. e. non-sparking, adequately sealed or intrinsically safe.

6. Presence of fire extinguisher

If any hot work is to be conducted on the refrigerating equipment or any associated parts, appropriate fire extinguishing equipment shall be available to hand. Have a dry powder or CO₂ fire extinguisher adjacent to the charging area.

a) Commissioning

- Ensure that the floor area is sufficient for the REFRIGERANT CHARGE or that the ventilation duct is assembled in a correct manner.
- Connect the pipes and carry out a leak test before charging with refrigerant.
- Check safety equipment before putting into service.

b) Maintenance

- Portable equipment shall be repaired outside or in a workshop specially equipped for servicing units with FLAMMABLE REFRIGERANTS.
- Ensure sufficient ventilation at the repair place.
- Be aware that malfunction of the equipment may be caused by refrigerant loss and a refrigerant leak is possible.
- Discharge capacitors in a way that won't cause any spark. The standard procedure to short circuit the capacitor terminals usually creates sparks.
- Reassemble sealed enclosures accurately. If seals are worn, replace them.
- Check safety equipment before putting into service.

c) Repair

- Portable equipment shall be repaired outside or in a workshop specially equipped for servicing units with FLAMMABLE REFRIGERANTS.
- Ensure sufficient ventilation at the repair place.
- Be aware that malfunction of the equipment may be caused by refrigerant loss and a refrigerant leak is possible.
- Discharge capacitors in a way that won't cause any spark.
- When brazing is required, the following procedures shall be carried out in the following order:

--Safely remove the refrigerant following local and national regulations. If the recovery is not required by national regulations, drain the refrigerant to the outside. Take care that the drained refrigerant will not cause any danger. In doubt, one person should guard the outlet.

Take special care that drained refrigerant will not float back into the building;

d) Decommissioning

- If the safety is affected when the equipment is putted out of service, the REFRIGERANT CHARGE shall be removed before decommissioning.
- Ensure sufficient ventilation at the equipment location.
- Be aware that malfunction of the equipment may be caused by refrigerant loss and a refrigerant leak is possible.
- Discharge capacitors in a way that won't cause any spark.
- Remove the refrigerant. If the recovery is not required by national regulations, drain the refrigerant to the outside. Take care that the drained refrigerant will not cause any danger. In doubt, one person should guard the outlet. Take special care that drained refrigerant will not float back into the building.
- When FLAMMABLE REFRIGERANTS except A2L REFRIGERANTS are used,
--Evacuate the refrigerant circuit.

7. No ignition sources

No person carrying out work in relation to a REFRIGERATING SYSTEM which involves exposing any pipe work shall use any sources of ignition in such a manner that it may lead to the risk of fire or explosion. All possible ignition sources, including cigarette smoking, should be kept sufficiently far away from the site of installation, repairing, removing and disposal, during which refrigerant can possibly be released to the surrounding space.

Prior to work taking place, the area around the equipment is to be surveyed to make sure that there are no flammable hazards or ignition risks. "No Smoking" signs shall be displayed.

8. Ventilated area

Ensure that the area is in the open or that it is adequately ventilated before breaking into the system or conducting any hot work. A degree of ventilation shall continue during the period that the work is carried out. The ventilation should safely disperse any released refrigerant and preferably expel it externally into the atmosphere.

9. Checks to the refrigerating equipment

Where electrical components are being changed, they shall be fit for the purpose and to the correct specification. At all times the manufacturer's maintenance and service guidelines shall be followed. If in doubt, consult the manufacturer's technical department for assistance. The following checks shall be applied to installations using.

FLAMMABLE REFRIGERANTS:

- The actual REFRIGERANT CHARGE is in accordance with the room size within which the refrigerant containing parts are installed;
- The ventilation machinery and outlets are operating adequately and are not obstructed;
- If an indirect refrigerating circuit is being used, the secondary circuit shall be checked for the presence of refrigerant;
- Marking to the equipment continues to be visible and legible. Markings and signs that are illegible shall be corrected;
- Refrigerating pipe or components are installed in a position where they are unlikely to be exposed to any substance which may corrode refrigerant containing components, unless the components are constructed of materials which are inherently resistant to being corroded or are suitably protected against being so corroded.

10. Checks to electrical devices

Repair and maintenance to electrical components shall include initial safety checks and component inspection procedures. If a fault exists that could compromise safety, then no electrical supply shall be connected to the circuit until it is satisfactorily dealt with. If the fault cannot be corrected immediately but it is necessary to continue operation, an adequate temporary solution shall be used. This shall be reported to the owner of the equipment so all parties are advised.

Initial safety checks shall include:

- That capacitors are discharged: this shall be done in a safe manner to avoid possibility of sparking;
- That no live electrical components and wiring are exposed while charging, recovering or purging the system;
- That there is continuity of earth bonding.

11. Repairs to sealed components

- 1) During repairs to sealed components, all electrical supplies shall be disconnected from the equipment being worked upon prior to any removal of sealed covers, etc. If it is absolutely necessary to have an electrical supply to equipment during servicing, then a permanently operating form of leak detection shall be located at the most critical point to warn of a potentially hazardous situation.
- 2) Sealed electrical components shall be replaced.

12. Repair to intrinsically safe components

Do not apply any permanent inductive or capacitance loads to the circuit without ensuring that this will not exceed the permissible voltage and current permitted for the equipment in use.

Intrinsically safe components must be replaced.

Replace components only with parts specified by the manufacturer. Other parts may result in the ignition of refrigerant in the atmosphere from a leak.

13. Cabling

Check that cabling will not be subject to wear, corrosion, excessive pressure, vibration, sharp edges or any other adverse environmental effects. The check shall also take into account the effects of aging or continual vibration from sources such as compressors or fans.

14. Detection of flammable refrigerants

Under no circumstances shall potential sources of ignition be used in the searching for or detection of refrigerant leaks. A halide torch (or any other detector using a naked flame) shall not be used. The following leak detection methods are deemed acceptable for all refrigerant systems. Electronic leak detectors may be used to detect refrigerant leaks but, in the case of FLAMMABLE REFRIGERANTS, the sensitivity may not be adequate, or may need re-calibration.

(Detection equipment shall be calibrated in a refrigerant-free area.)

Ensure that the detector is not a potential source of ignition and is suitable for the refrigerant used.

Leak detection equipment shall be set at a percentage of the LFL of the refrigerant and shall be calibrated to the refrigerant employed, and the appropriate percentage of gas (25 % maximum) is confirmed.

Leak detection fluids are also suitable for use with most refrigerants but the use of detergents containing chlorine shall be avoided as the chlorine may react with the refrigerant and corrode the copper pipe-work.

If a leak is suspected, all naked flames shall be removed/extinguished.

If a leakage of refrigerant is found which requires brazing, all of the refrigerant shall be recovered from the system, or isolated (by means of shut off valves) in a part of the system remote from the leak. Removal of refrigerant shall be according to Removal and evacuation.

15. Removal and evacuation

When breaking into the refrigerant circuit to make repairs -or for any other purpose -conventional procedures shall be used. However, for flammable refrigerants it is important

that best practice be followed, since flammability is a consideration.

The following procedure shall be adhered to:

- Safely remove refrigerant following local and national regulations;
- Purge the circuit with inert gas(optional for A2L);
- Evacuate(optional for A2L);
- Continuously flush or purge with inert gas when using flame to open circuit ;
- Open the circuit.

The refrigerant charge shall be recovered into the correct recovery cylinders if venting is not allowed by local and national codes. For appliances containing flammable refrigerants, the system shall be purged with oxygen-free nitrogen to render the appliance safe for flammable refrigerants. This process might need to be repeated several times. Compressed air or oxygen shall not be used for purging refrigerant systems. For appliances containing flammable refrigerants, refrigerants purging shall be achieved by breaking the vacuum in the system with oxygen-free nitrogen and continuing to fill until the working pressure is achieved, then venting to atmosphere, and finally pulling down to a vacuum (optional for A2L).

This process shall be repeated until no refrigerant is within the system (optional for A2L). When the final oxygen-free nitrogen charge is used, the system shall be vented down to atmospheric pressure to enable work to take place.

The outlet for the vacuum pump shall not be close to any potential ignition sources, and ventilation shall be available.

16. Charging procedures

In addition to conventional charging procedures, the following requirements shall be followed.

- Ensure that contamination of different refrigerants does not occur when using charging equipment. Hoses or lines shall be as short as possible to minimise the amount of refrigerant contained in them.
- Cylinders shall be kept in an appropriate position according to the instructions.
- Ensure that the REFRIGERATING SYSTEM is earthed prior to charging the system with refrigerant.
- Label the system when charging is complete (if not already).
- Extreme care shall be taken not to overfill the REFRIGERATING SYSTEM. Prior to recharging the system, it shall be pressure-tested with the appropriate purging gas. The system shall be leak-tested on completion of charging but prior to commissioning. A follow up leak test shall be carried out prior to leaving the site.

17. Decommissioning

Before carrying out this procedure, it is essential that the technician is completely familiar with the equipment and all its detail. It is recommended good practice that all refrigerants are recovered safely. Prior to the task being carried out, an oil and refrigerant sample shall be taken in case analysis is required prior to re-use of recovered refrigerant. It is essential that electrical power is available before the task is commenced.

- a) Become familiar with the equipment and its operation.
- b) Isolate system electrically.
- c) Before attempting the procedure, ensure that:
 - Mechanical handling equipment is available, if required, for handling refrigerant cylinders;

- All personal protective equipment is available and being used correctly;
 - The recovery process is supervised at all times by a competent person;
 - Recovery equipment and cylinders conform to the appropriate standards.
- d) Pump down refrigerant system, if possible.
- e) If a vacuum is not possible, make a manifold so that refrigerant can be removed from various parts of the system.
- f) Make sure that cylinder is situated on the scales before recovery takes place.
- g) Start the recovery machine and operate in accordance with instructions.
- h) Do not overfill cylinders (no more than 80 % volume liquid charge).
- i) Do not exceed the maximum working pressure of the cylinder, even temporarily.
- j) When the cylinders have been filled correctly and the process completed, make sure that the cylinders and the equipment are removed from site promptly and all isolation valves on the equipment are closed off.
- k) Recovered refrigerant shall not be charged into another REFRIGERATING SYSTEM unless it has been cleaned and checked.

18. Labelling

Equipment shall be labelled stating that it has been de-commissioned and emptied of refrigerant.

The label shall be dated and signed. For appliances containing FLAMMABLE REFRIGERANTS, ensure that there are labels on the equipment stating the equipment contains FLAMMABLE REFRIGERANT.

19. Recovery

When removing refrigerant from a system, either for servicing or decommissioning, it is recommended good practice that all refrigerants are removed safely. When transferring refrigerant into cylinders, ensure that only appropriate refrigerant recovery cylinders are employed. Ensure that the correct number of cylinders for holding the total system charge is available.

All cylinders to be used are designated for the recovered refrigerant and labelled for that refrigerant (i. e. special cylinders for the recovery of refrigerant). Cylinders shall be complete with pressure-relief valve and associated shut-off valves in good working order.

Empty recovery cylinders are evacuated and, if possible, cooled before recovery occurs. The recovery equipment shall be in good working order with a set of instructions concerning the equipment that is at hand and shall be suitable for the recovery of the flammable refrigerant. If in doubt, the manufacturer should be consulted. In addition, a set of calibrated weighing scales shall be available and in good working order. Hoses shall be complete with leak-free disconnect couplings and in good condition.

The recovered refrigerant shall be processed according to local legislation in the correct recovery cylinder, and the relevant waste transfer note arranged. Do not mix refrigerants in recovery units and especially not in cylinders.

If compressors or compressor oils are to be removed, ensure that they have been evacuated to an acceptable level to make certain that flammable refrigerant does not remain within the lubricant.

The compressor body shall not be heated by an open flame or other ignition sources to accelerate this process. When oil is drained from a system, it shall be carried out safely.

General Safety Instruction

1. The appliance is for indoor use only.
2. Do not use the unit on a socket under repairs or not installed properly.
3. Do not use the unit, follow these precautions:
 - A: Near to source of fire.
 - B: An area where oil is likely to splash.
 - C: An area exposed to direct sunlight.
 - D: An area where water is likely to splash.
4. All the sockets must comply with the local electric safety requirements. If necessary, please check it for the requirements.
5. Children should be supervised to ensure that they do not play with the appliance.
6. If the supply cord is damaged, it must be replaced by the manufacturer, its service agent or similarly qualified persons in order to avoid a hazard.
7. This appliance is not intended for use by persons (including children) with reduced physical, sensory or mental capabilities, or lack of experience and knowledge, unless they have been given supervision or instruction concerning use of the appliance by a person responsible for their safety.
8. The appliance shall be installed in accordance with national wiring regulations.
9. The applicable operating temperature range for this unit is 41°F -95°F ;
Model Specifications for Fuse : 3.15A,250VAC;

Recycling

This marking indicates that this product should not be disposed with other household wastes. To prevent possible harm to the environment or human health from uncontrolled waste disposal recycle it responsibly to promote the sustainable reuse of material resources.



SAFETY PRECAUTIONS

- Place the dehumidifier on a flat surface to minimize vibration and noise.
- Before use, check the power cord for any damage. Do not operate the dehumidifier if the power cord or plug is damaged.
- Insert the three-prong plug into a matching electrically grounded outlet (120V/60Hz, at least 5A). Do not cut off the third prong or modify the power cord length.
- Avoid operating the dehumidifier in standing water and ensure the motor and wiring stay dry.
- Never immerse the dehumidifier in water or other liquids.
- Keep the dehumidifier away from heat-generating devices, flammable materials, or hazardous substances.
- Turn off and unplug the power supply before cleaning or storing the dehumidifier.
- Always grasp the plug (not the cord) to unplug.
- Do not insert fingers or other objects into the air inlet or outlet.
- Avoid sitting, standing, or placing heavy objects on the dehumidifiers.
- Disconnect the power if you notice strange sounds, odors, or smoke coming from the dehumidifier.
- Do not operate or turn off the dehumidifier by plugging in or unplugging it. Use the control panel instead.
- This dehumidifier should only be used by adults who have read the manual and understand its operation.
- This dehumidifier is not intended for use by individuals (including children) with reduced physical, sensory or mental capabilities, unless supervised or instructed by someone responsible for their safety.
- Children should be supervised to ensure that they do not play with the dehumidifier.
- Do not tilt the dehumidifier while it is operating to prevent water overflow.

PARTS IDENTIFICATION

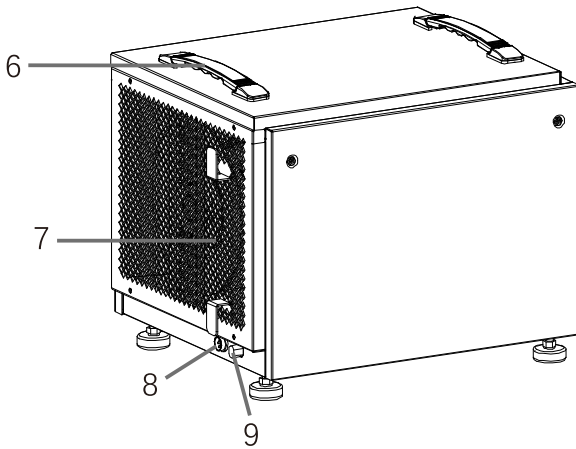
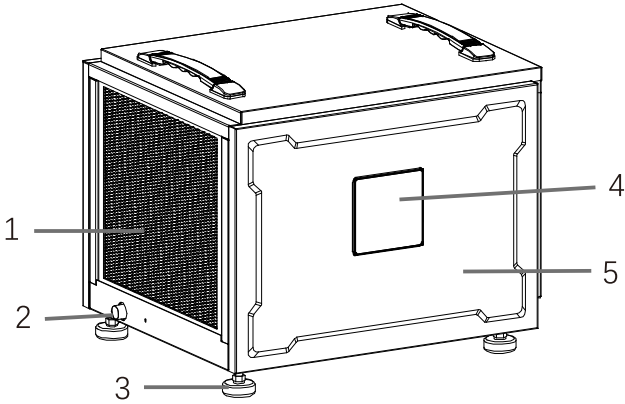

- | | |
|-------------------------|------------------------|
| 1. Air Inlet | 6. Handle |
| 2. Gravity Drain Outlet | 7. Air Outlet |
| 3. Adjustable Foot | 8. Remote Control Port |
| 4. Control Panel | 9. Power Cord Port |
| 5. Service Panel | |

NOTE: DO NOT OBSTRUCT THE AIR INLET OR OUTLET.

INSTALLATION INSTRUCTIONS

1. Recommended Installations

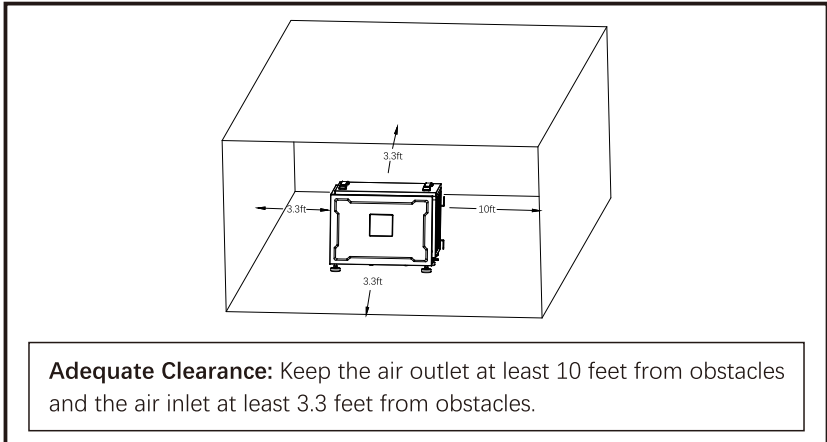

Following the above recommendations will help prevent the discharged air from being drawn back into the unit, ensuring the dehumidifier operates effectively.

2. Position Your Dehumidifier

- Install the dehumidifier horizontally to minimize vibration and or noise.
- You can adjust the feet to level the dehumidifier.

To adjust the feet,

- Turn the nut in a clockwise direction to get the nut loosen;
- Turn the foot in a clockwise direction to get the foot down or turn the foot in a counterclockwise direction to get the foot up;
- Turn the nut in a counterclockwise direction to fix the foot.

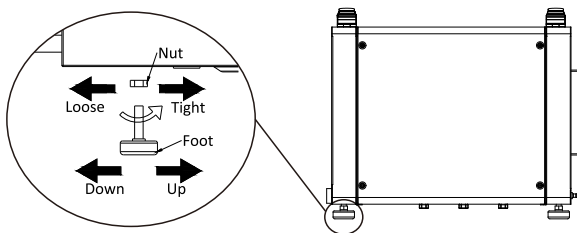

For optimal outcomes, please:

- Operate your dehumidifiers in an enclosed area.
- Close all doors and windows that open to the outside to maximize water removal efficiency.
- Place your dehumidifier away from obstructions, and keep it away from anything that could block airflow into and out of the unit.

3. Set up the Drainage System

Drain by Gravity

If the drainage point is below the gravity drain outlet and located nearby, with no upward lift required, you may use gravity drainage.

When using gravity to drain:

- Attach the gravity drain hose to the Gravity Drain Outlet.
- Direct the hose to a suitable drainage facility, ensuring it is positioned lower than the dehumidifier's drain outlet and free from kinks or blockages.

OPERATION INSTRUCTIONS

1. Plug in the Electrical Cord

IMPORTANT

Please let the dehumidifier sit outside the box for **24 hours** before initial plugging in.

To properly operate the dehumidifier, please plug it into a GFCI-protected 120-volt outlet with a rating of at least 5 amps. Uncoil the power cord and securely connect it to an appropriate outlet.

Note: When the dehumidifier is first plugged into AC power, the control panel display will light up for a second, which is part of the dehumidifier's self-diagnosis procedure and no action is required. This indicates that the dehumidifier is functioning correctly and ready to operate effectively. You will still need to press the POWER button to turn the dehumidifier on.

2. Control Panel Instruction

The control panel of the dehumidifier features a user-friendly interface with 4 buttons and an LED screen. Press the POWER Button to turn the dehumidifier on. After turning on the dehumidifier, the LED screen will display the readouts.

If not been operated for over 30 seconds, the control panel will become dim until pressed buttons again.

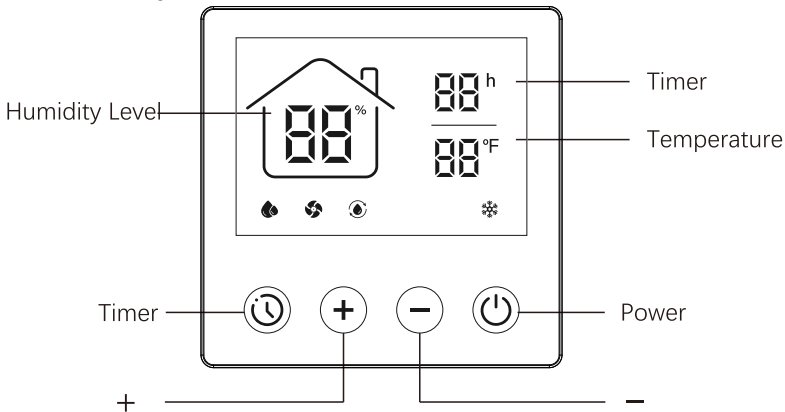

2.1. The Control Buttons

- **Power Button:** Press to toggle the dehumidifier on/off.
- **+ Button:** Press to increase humidity or timer settings.
- **- Button:** Press to decrease humidity or timer settings.
- **Timer Button:** Press to set a timer.

2.2. The LED Display

 is humidity percentage value. If no operations on the control panel, this number is the humidity readout of the inlet air the dehumidifier detects which is similar to the current room humidity level. When you are pressing the **+** or **-** button to set the target humidity percentage value, this digital number will turn to display the previous setting value and keep blinking.

^h illuminates when the timer function is enabled and disappears when the timer function is disabled.

^{°F} is the temperature readout of the inlet air the dehumidifier detects which is similar to the current room temperature.

 **Water Droplet Icon:** It illuminates when the compressor is running and disappears when the compressor stops running.

Note: In the following cases, it is normal if the water droplet icon disappears which means the compressor stops or does not kick in.

- A. The humidity set-point is NOT at least 3% lower than the room humidity readout value (in this case, please double-check your setting);
- B. The room humidity level has reached the set-point, so the dehumidifier automatically stops running;
- C. The dehumidifier was just turned on and may take a few seconds for the compressor to kick in;
- D. The dehumidifier was restarted in a brief moment, the compressor is under delay protection status.

 **Fan Icon:** It illuminates when the fan is running and disappears when the compressor stops running.

 **Continuous Mode Icon:** This icon illuminates when the humidity set point is 10%, which means the dehumidifier will dehumidify continuously.

 **Defrost Icon:** It illuminates when the dehumidifier detects frost on the interior. During defrosting, the fan operates while the compressor does not, and the defrost icon flashes until the frost melts. The dehumidifier will automatically begin to dehumidify and the “Defrost” icon will disappear once the defrosting process is complete.

Note: Frequent defrosting may occur when the room temperature is too low, which can reduce dehumidification efficiency. For optimal performance, keep the room temperature above 65°F. If the temperature is below 60°F, consider adding heat to maintain proper drying.

3. Operate the Dehumidifier

3.1 Turn on the dehumidifier

Press the **Power** button to turn the dehumidifier on.

3.2 Check Room Humidity

Refer to the **RH** on the control panel to check the current room humidity percentage.

3.3 Set Desired Humidity

Press the **+** or **-** button to set your desired humidity between 10% and 90%, in 1% increments. Recommended settings typically range between 40% and 60%. The **RH** digital number will turn to display the previous target humidity set point and blink to indicate the setting is being adjusted.

Ensure the set humidity is at least 3% lower than the room humidity. After selecting your target value, wait for automatic registration after 5 seconds.

Once a target humidity is set, the dehumidifier will automatically cycle on and off to maintain humidity within +3% of the set level:

- The unit will run until the humidity drops to 3% below the target, then enter standby mode-the compressor and fan will stop running.
- When the humidity rises to 3% above the target, the dehumidifier will automatically restart and run until it again reaches 3% below the set level.

Note 1: The target humidity needs to be at least 3% lower than the current room humidity. If not, the unit will remain in standby mode until the room humidity rises 3% above the target.

Note 2: To run the unit continuously, set the target humidity to 10% to activate Continuous Mode.

3.4 Set Auto On/off Timer

The TIMER function allows scheduling the dehumidifier to turn on (AUTO-ON) or off (AUTO-OFF) after a delay of 1 to 24 hours.

- **To set AUTO-ON timer:** When the dehumidifier is off, selecting Timer activates it after the set hours.
- **To set AUTO-OFF timer:** When the dehumidifier is on, selecting Timer turns it off after the set hours.

Follow these steps to set the TIMER:

- Press the Timer Button, the Timer icon illuminates and the timer digital number changes into 00 H, flashing.

- Adjust the timer setting by pressing the **+** or **-** button for 1-hour increments, up to 24 hours.
- After selecting the target timer value, wait for automatic confirmation after 5 seconds.
- The timer countdown displays remaining time until the dehumidifier starts or stops.
- To disable the timer function, manually turn ON/OFF the dehumidifier, or set the timer to 00.

NOTE:

- Ensure power is supplied to the dehumidifier before setting AUTO ON TIMER.
- For AUTO ON setting, turn on the dehumidifier to select a desired humidity level first; otherwise, it maintains the previous setting.
- You can only set AUTO ON timer when the dehumidifier is off or set AUTO OFF timer when it's on, but not be able to set both AUTO ON and AUTO OFF timer simultaneously.
- TIMER functions only once, not cycling the dehumidifier indefinitely.
- TIMER is disabled if the dehumidifier is manually powered on/off.

3.5 Turn the Dehumidifier off

Press the **Power** button to turn off the dehumidifier.

Note: To protect the compressor, the fan runs for 5 seconds after the dehumidifier shuts off. So please do not disconnect the power cord to force the dehumidifier to stop. Always use the **Power** button.

4. Remote Controller Installation Instructions

This dehumidifier allows the onboard control panel to be used as a remote controller using a 33ft (10m) signal cable (**needs to be purchased separately**). This enables the unit to be placed, for example, in a basement while the control panel is installed upstairs.

⚠ Safety First: Always disconnect the unit from power before performing any steps.

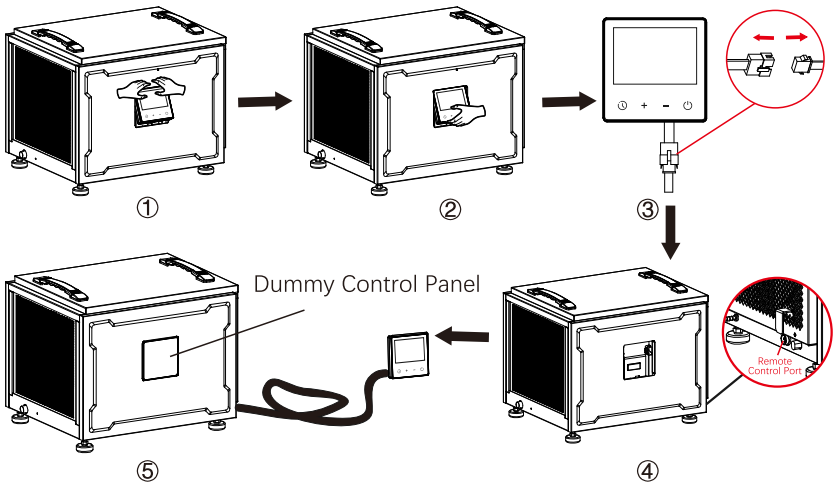

Steps:

1. Release the control panel from the unit:

Push the top of the control panel gently toward the unit until the bottom edge lifts slightly. Some light force may be required, but do not use excessive force.

2. Remove the control panel:

Grab the lifted bottom edge and pull the panel downward carefully. Apply light force; avoid pulling too hard to prevent damage.

3. Disconnect the panel cable:

Carefully detach the cable at the back of the control panel from the unit.

4. Connect the 33ft (10m) signal cable (needs to be purchased separately):

Connect one end to the control panel and the other end to the remote controller port on the dehumidifier. Ensure the cable is properly connected before operating the unit remotely.

Optional: Install the dummy control panel on the unit

Place the dummy control panel (included with the 33ft / 10m signal cable) back onto the unit and gently push it into place until you hear a click.

Caution: Do not pinch or damage the original control panel cable while installing the dummy control panel.

Note: The unit functions normally even without the dummy control panel installed.

SMART FUNCTIONS

1. Compressor 3-Minute Delay

To prevent any potential damage, the dehumidifier incorporates a 3-minute delay after a complete cycle. Following this interval, the compressor automatically starts operation. In essence, if you power off and restart the dehumidifier immediately, the compressor initiates after a 3-minute delay. During this time, the Fan icon is illuminating continuously on the LED screen and until the compressor kicks in, the water droplets icon illuminates.

2. Auto Defrost

If the temperature drops below 60°F, frost may form on the coils. When this happens, the unit will automatically pause the compressor and run the fan to defrost. The Defrost icon will illuminate during this process. Once the frost has cleared, the unit will resume normal operation.

3. Auto-Restart

If a power outage occurs while the dehumidifier is running, it will automatically restart with the previous settings (excluding the timer) once power is restored.

CARE&MAINTENANCE

WARNING:

Ensure the dehumidifier is turned OFF and unplugged before performing any cleaning or maintenance.

1. Cleaning the Dehumidifier

- Wipe the dehumidifier housing with a soft damp cloth.
- Avoid submerging or applying water directly to the dehumidifier or control panel to prevent damage to electronic components.
- Do not use chemical solvents such as benzene, alcohol, gasoline or other heavy-duty cleaners, as they may harm the surface.

2. Cleaning the Air Filter

A blocked filter can impede performance. Clean the air filter every 2 weeks or more frequently in dusty or pet-fur-laden environments. The air filter is located on the side of the unit.

Follow the steps below to clean the filter:

- Take out the filter.
- Use a vacuum cleaner with a soft brush attachment to remove large debris or dust.
- Wash the filter in lukewarm, soapy water (below 104°F) or use a neutral cleaning agent.
- Rinse the filter with clean water and thoroughly dry it.
- Re-install the filter.

Note: DO NOT operate the dehumidifier without a filter because dirt and lint will clog it, reducing performance.

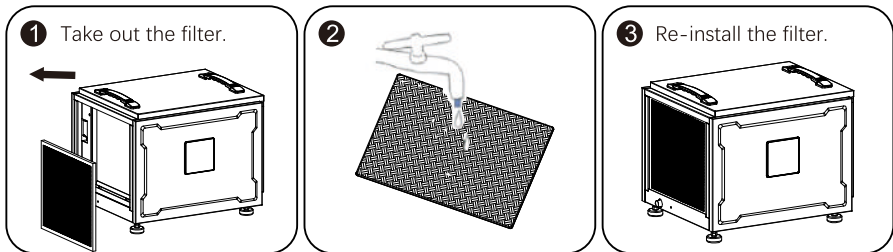

3. Storage Guidelines

- Turn off the unit, disconnect power, and remove the gravity drainage plug.
- Let the unit sit for 24 hours to allow all internal water to drain completely.
- Clean the dehumidifier and air filter thoroughly, ensuring everything is clean and dry.
- Wrap the cord and hose, bundling them for safekeeping.
- Cover the dehumidifier with a plastic bag to protect it from dust and debris.
- Store the dehumidifier upright in a dry, well-ventilated place.

Trouble Shooting Guide

The following chart provides solutions for common problems that may arise. If the issue persists after troubleshooting, or if it's not addressed in the chart below, please contact Airecoler customer service for professional support at service@airecoler.com.

Problem	Possible Cause	Solution
Dehumidifier does not operate	No power to dehumidifier	Plug it into a working outlet
	Not turned on	Turn the dehumidifier on
	Has not set it properly	Make sure the set humidity level is at 3% lower than the inlet humidity reading
	Error code displays	Contact customer service
Dehumidifier collects little water	Too low humidity level	Try again until the humidity level exceeds 40%
	Insufficient working time	Allow more working time
	Filter is blocked	Clean filter
	Air Inlet or Outlet is blocked	Clear the obstructions
	Low ambient temperature	Heat up the room
Condensate hose is blocked	Check hose for restrictions	
Dehumidifier operating, but room not dry	Doors and windows are open	Seal room from external areas
Abnormal Noise	The dehumidifier has not been placed properly	Place the dehumidifier in a horizontal position
	Filter is blocked	Clean filter
Humidity reading remains at 10RH%, (far from the actual room humidity)	Humidity sensor failure	Set the target humidity percentage value at 10RH%, the dehumidifier works normally, which means this failure does not affect the function of this dehumidifier. Repair and replace the humidity sensor.
Humidity reading remains at "99%RH" (far from the actual room humidity)	Water on the surface of the humidity sensor	Please let the dehumidifier work for a period of time, the humidity reading will get normal after the water on the surface of the humidity sensor is evaporated.
	Humidity sensor failure	The dehumidifier works normally, which means this problem does not affect the function of this dehumidifier. Repair and replace the humidity sensor.

Note: It is normal that the dehumidifier pulls warm air out.

WARRANTY

This warranty applies only to products purchased from Airecoler or its authorized dealers and must be installed, operated, and maintained according to the provided instructions.

2 Years Full Warranty (1 year standard + 1 year with product registration)

Airecoler warrants to the original purchaser that this product is free from defects in materials and workmanship for 2 years from the date of purchase. During this period, Airecoler will, at its discretion, repair or replace any defective parts or units. In rare cases where repair or replacement is not feasible, a refund may be issued as a last resort.

5-Year Limited Warranty on Refrigeration System

The refrigeration system—including compressor, condenser, and evaporator—is warranted against defects in materials or workmanship for five years from the purchase date. Labor and shipping costs are excluded after the initial two-year full warranty period.

Note: If the dehumidifier is replaced, the warranty period for the replacement dehumidifier continues from the original purchase date.

Exclusions

This warranty does not cover:

(1) Damage resulting from:

- Normal wear and tear
- Misuse, abuse, accidents, or failure to follow the operating instructions
- Exposure to liquids or foreign particles
- Unauthorized servicing or modifications

(2) Second-hand products or products purchased through liquidation sales.

(3) Products purchased from unauthorized dealers.

While these terms define our warranty, we encourage customers to contact us with any concerns, regardless of warranty status. We are committed to delivering the best possible support.

For assistance, please contact Airecoler Customer Service as follows:

 **Website:** www.airecoler.com

 **Phone:** Available via our website

 **Email:** service@airecoler.com

 **Live Chat:** Available via our website



www.airecoler.com