



# DEEBOT **X12** FAMILY

Instruction Manual

## IMPORTANT SAFETY INSTRUCTIONS

### IMPORTANT SAFETY INSTRUCTIONS READ ALL INSTRUCTIONS BEFORE USING THIS APPLIANCE.

When using an electrical appliance, basic precautions should always be followed, including the following:

**WARNING:** Read all safety warnings and instructions. Failure to follow the warnings and instructions may result in electric shock, fire, or serious injury.

1. Do not allow to be used as a toy. Close attention is necessary when used by or near children.
2. Clear the area to be cleaned. Remove power cords and small objects from the floor that could entangle the Appliance. Tuck rug fringe under the rug base, and lift items such as curtains and tablecloths off the floor.
3. If there is a drop off in the cleaning area due to a step or stairs, you should operate the Appliance to ensure that it can detect the step without falling over the edge. It may become necessary to place a physical barrier at the edge to keep the unit from falling. Make sure the physical barrier is not a trip hazard.
4. Only use as described in this manual. Only

use attachments recommended or sold by the manufacturer.

5. Do not handle plug or appliance with wet hands.
6. Non-rechargeable batteries are prohibited.
7. Do not use without Dust Bin and/or Filters in place.
8. Do not operate the vacuum in an area where there are lit candles or fragile objects on the floor to be cleaned.
9. Do not use and store in extremely hot or cold environments (below  $-5^{\circ}\text{C}$  / $23^{\circ}\text{F}$  or above  $40^{\circ}\text{C}$  / $104^{\circ}\text{F}$ ). Please charge the robot in temperature above  $0^{\circ}\text{C}$  / $32^{\circ}\text{F}$  and below  $40^{\circ}\text{C}$  / $104^{\circ}\text{F}$ .
10. Keep hair, loose clothing, fingers, and all parts of body away from any openings and moving parts.
11. Do not operate the Appliance in a room where an infant or child is sleeping.
12. For INDOOR use ONLY. Do not use the Appliance in outdoor, commercial or industrial environments. Do not use Appliance on wet surfaces or surfaces with standing water.
13. Do not allow the Appliance to pick up large objects like stones, large pieces of paper, or any item that may clog the Appliance.
14. Do not use to pick up flammable or combustible

- materials such as gasoline, printer, or copier toner, or use in areas where they may be present.
15. Do not pick up anything that is burning or smoking, such as cigarettes, matches, hot ashes, or anything that could cause a fire.
  16. Do not put any object into openings. Do not use with any opening blocked; keep free of dust, lint, hair, and anything that may reduce air flow.
  17. Take care not to damage the power cord. Do not pull on or carry the Appliance or Docking Station by the power cord, use the power cord as a handle, close a door on the power cord, or pull power cord around sharp edges or corners. Do not run Appliance and Docking Station over the power cord. Keep power cord away from hot surfaces. Do not unplug by pulling on cord. To unplug, grasp the plug, not the cord.
  18. If the power cord is damaged, it must be replaced by the manufacturer or its service agent in order to avoid a hazard.
  19. Do not use with a damaged power cord or plug. Do not use the Appliance or Docking Station if it is not working properly, has been dropped, damaged, left outdoors, or come in contact with water. It must be repaired by the manufacturer or its service agent in order to avoid a hazard.
  20. Turn OFF the power switch before cleaning or maintaining the Appliance. Turn off all controls before unplugging. Always turn off this appliance before connecting or disconnecting motorized nozzle.
  21. Turn OFF the Power Switch before removing the Dust Bin.
  22. Remove the Appliance from the Docking Station, and turn OFF the power switch to the Appliance before removing the battery for disposal of the Appliance.
  23. The battery must be removed and discarded according to local laws and regulations before disposal of the Appliance.
  24. Please dispose of used batteries according to local laws and regulations.
  25. Do not incinerate the Appliance even if it is severely damaged. The batteries can explode in a fire.
  26. When not using the Docking Station, unplug from outlet when not in use and before servicing.
  27. The Appliance must be used in accordance with the directions in this Instruction Manual. Ecovacs Home Service Robotics cannot be held liable or responsible for any damages or injuries caused by improper use.

28. Prevent unintentional starting. Ensure the switch is in the off position before connecting to battery pack, picking up or carrying the appliance.
29. When battery pack is not in use, keep it away from other metal objects, like paper clips, coins, keys, nails, screws, or other small metal objects, that can make a connection from one terminal to another. Shorting the battery terminals together may cause burns or a fire.
30. Under abusive conditions, liquid may be ejected from the battery; avoid contact. If contact accidentally occurs, flush with water. If liquid contacts eyes, additionally seek medical help. Liquid ejected from the battery may cause irritation or burns.
31. Do not use a battery pack or appliance that is damaged or modified. Damaged or modified batteries may exhibit unpredictable behavior resulting in fire, explosion, or risk of injury.
32. Do not expose a battery pack or appliance to fire or excessive temperature. Exposure to fire or temperature above 130°C may cause explosion. The temperature of 130°C can be replaced by the temperature of 265°F.
33. Follow all charging instructions and do not charge the battery pack or appliance outside of the temperature range specified in the instructions. Charging improperly or at temperatures outside of the specified range may damage the battery and increase the risk of fire.
34. Have servicing performed by a qualified repair person using only identical replacement parts. This will ensure that the safety of the product is maintained.
35. Do not modify or attempt to repair the appliance or the battery pack (as applicable) except as indicated in the instructions for use and care.
36. Place the cords from other appliances out of the area to be cleaned.
37. Do not operate the vacuum in a room that has lit candles on furniture that the vacuum may accidentally hit or bump into.
38. Do not allow children to sit on the vacuum.
39. Use only as described in this manual. Use only manufacturer's recommended attachments.
40. Recharge only with the charger specified by the manufacturer. A charger that is suitable for one type of battery pack may create a risk of fire when used with another battery pack.
41. Use appliances only with specifically designated battery packs. Use of any other battery packs may create a risk of injury and fire.

42. The robot contains batteries that are only replaceable by skilled persons. To replace the robot's battery, please contact Customer Service.
43. If the robot will not be used for a long time, fully charge the robot and power OFF for storage and unplug the Docking Station.
44. To Reduce The Risk Of Electric Shock – Do not use on wet surfaces. Do not expose to rain. Store indoors.
45. To Reduce The Risk Of Injury From Moving Parts – Unplug Before Servicing.
46. Risk Of Injury. Brush May Start Unexpectedly. Unplug Before Cleaning or Servicing.
47. To reduce the risk of injury, user must read the Instruction Manual.
48. To Reduce The Risk Of Electric Shock – Do not use outdoors or on wet surfaces.
49. Please make sure your power supply voltage matches the power voltage marked on the Docking Station.
50. Do not use the Docking Station if it is damaged.
51. The plug must be removed from the receptacle before cleaning or maintaining the Docking Station.
52. Power Switch: "I"=ON, "O"=OFF.

|   |                     |
|---|---------------------|
| ≡ | Direct current      |
| ~ | Alternating current |

This Device Complies with DHHS Radiation Rules, 21CFR Chapter 1, Subchapter J.

### Federal Communications Commission (FCC) Interference Statement

**NOTE:** This equipment has been tested and found to comply with the limits for a Class B digital device, pursuant to Part 15 of the FCC Rules.

These limits are designed to provide reasonable protection against harmful interference in a residential installation. This equipment generates, uses, and can radiate radio frequency energy and, if not installed and used in accordance with the instructions, may cause harmful interference to radio communications.

However, there is no guarantee that interference will not occur in a particular installation. If this equipment does cause harmful interference to radio or television reception, which can be determined by turning the equipment off and on, the user is encouraged to try to correct the interference by one or more of the following measures:

- Reorient or relocate the receiving antenna.

- Increase the separation between the equipment and receiver.
- Connect the equipment into an outlet on a circuit different from that to which the receiver is connected.
- Consult the dealer or an experienced radio/TV technician for help.

This device complies with Part 15 of the FCC Rules. Operation is subject to the following two conditions:

- (1) This device may not cause harmful interference, and
- (2) this device must accept any interference received, including interference that may cause undesired operation.

**Caution:** Changes or modifications to this unit not expressly approved by the party responsible for compliance could void the user's authority to operate the equipment.

This device contains licence-exempt transmitter(s)/ receiver(s) that comply with Innovation, Science and Economic Development Canada's licence-exempt RSS(s). Operation is subject to the following two conditions:

- (1) This device may not cause interference.
- (2) This device must accept any interference, including interference that may cause undesired operation of the device.

## RF exposure warning

This equipment complies with FCC radiation exposure limits set forth for an uncontrolled environment.

This equipment must be installed and operated in accordance with provided instructions and the antenna(s) used for this transmitter must be installed to provide a separation distance of at least 20 cm from all persons and must not be collocated or operating in conjunction with any other antenna or transmitter.

MPE caution (for mobile device under Part 15.247device)

To satisfy FCC & IC RF exposure requirements, a separation distance of 20 cm or more should be maintained between the antenna of this device and persons during device operation.

To ensure compliance, operations at closer than this distance is not recommended.

To disable the Wi-Fi module on DEEBOT, follow these steps: power on the robot, then place it on the OMNI Station, ensuring that the Charging Contacts on DEEBOT and the Station are properly connected, and press and hold the  for 30 s until you hear beeps.

To enable DEEBOT's Wi-Fi, please restart the robot or tap the .

## SAVE THESE INSTRUCTIONS

For INDOOR household use ONLY.

This device contains licence-exempt transmitter(s)/ receiver(s) that comply with Innovation, Science and Economic Development Canada's licence-exempt RSS(s). Operation is subject to the following two conditions:

- (1) This device may not cause interference.
- (2) This device must accept any interference, including interference that may cause undesired operation of the device.

To satisfy FCC&IC RF exposure requirements, a separation distance of 20 cm or more should be maintained between the antenna of this device and persons during device operation.

To ensure compliance, operations at closer than this distance is not recommended.

## **Device Update**

Typically, some devices are updated bi-monthly, but not always so specific.

Some devices, especially those that went on sale more than three years ago, will only be updated if a critical vulnerability is found and fixed.

# PACKAGE CONTENTS

## 1 Package Contents

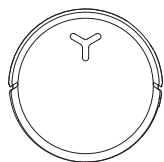

DEEBOT

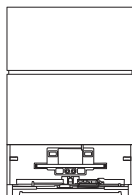

OMNI Station

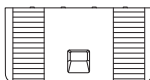

Base

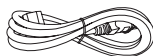

Power Cord



Instruction Manual



Corner Guards



ECOVACS DEEBOT Cleaning Solution



ECOVACS DEEBOT Heavy-duty Cleaning Solution

### Note:

\*A thoughtful pair of corner guards is included to enhance user safety and improve handling comfort. To install: Align the inner slot of the corner guard with the edge and press it into place. Compatible with all DEEBOT corner designs.

\*Figures in this manual are for reference only and may differ from the appliance. Product design and specifications are subject to changes without notice.

## 2 Product Diagram

### 1. DEEBOT Front View

Buttons on DEEBOT:

Press: Toggle start/Pause

Press for 3 s: Return to the station

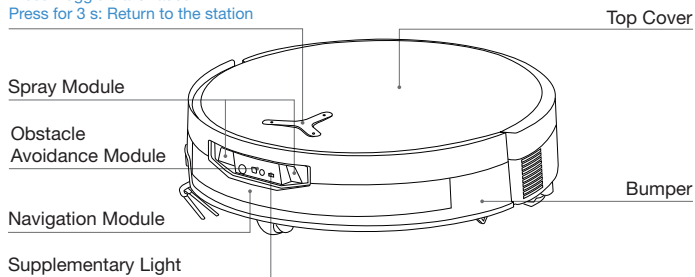

### 2. DEEBOT Bottom View

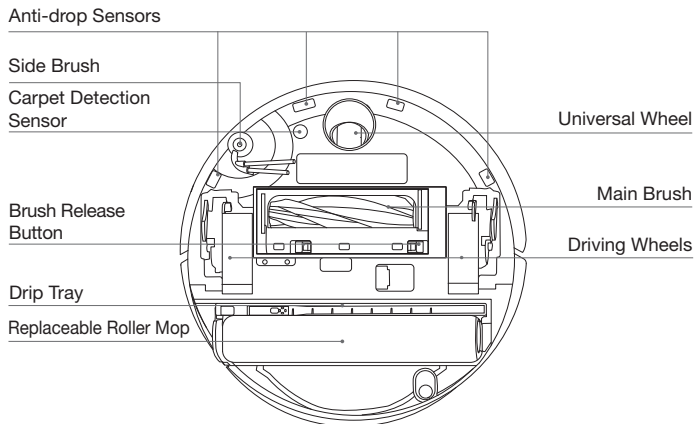

### 3. Inside DEEBOT (Under the Top Cover)

#### RESET Button

**Network Setup:** Press the RESET Button, and a voice prompt will be heard to connect DEEBOT to the App.

**Restore default settings:** Press and hold the RESET button for 5 seconds. After hearing the voice prompt, the startup music will play, and DEEBOT will be restored to its default settings.

Exercise caution when using this function.

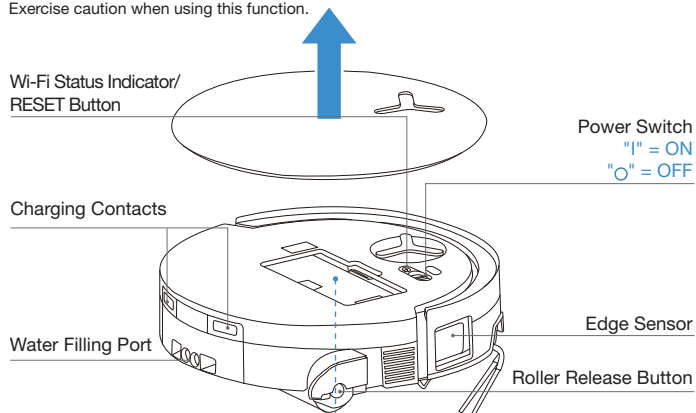

### 4. Dust Bin

Dust Bin Cover

Filter

Filter Holder

Dust Disposal Port

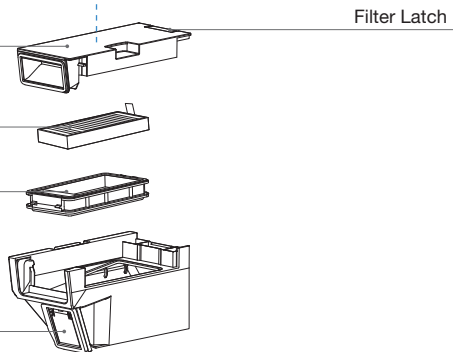

### 5. OMNI Station Front View

Dirty Water Tank

Clean Water Tank

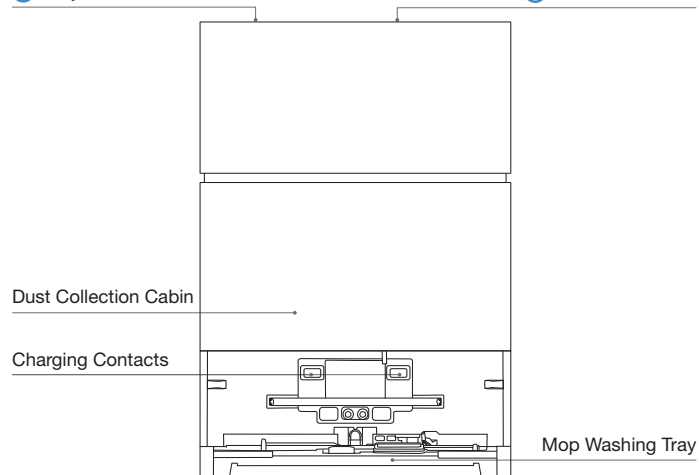

#### Note:

- Flashing Orange or Red: Please check the ECOVACS HOME App for the cause of the malfunction.
- If DEEBOT fails to charge, please wipe the charging contacts with a clean and dry cloth.

## 6. OMNI Station Back View

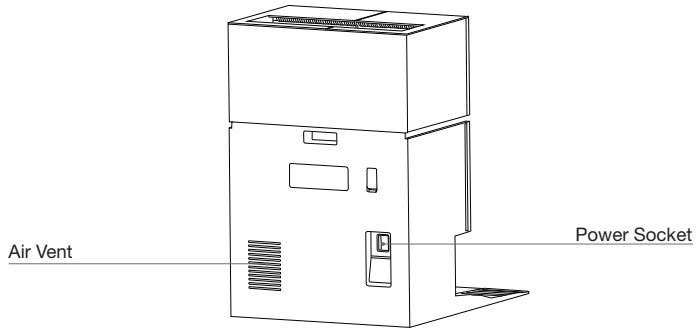

## 7. Indicator Light on DEEBOT

| Light Effect    | State                 |
|-----------------|-----------------------|
| Breathing White | Charging              |
| Solid White     | Fully Charged/Running |
| Solid Red       | Low Battery           |
| Flashing Red    | DEEBOT Alarm          |
| Flashing Orange | Station Alarm         |

## 8. Sensors Overview

| Name                      | Functional Description   |
|---------------------------|--|
| Navigation Module         | Laser Ranging is applied to measure the distance between DEEBOT and surrounding objects based on the time difference of reflection, allowing the module to map against the objects around while DEEBOT is moving. The detection range is 10 m.   |
| Obstacle Avoidance Module | Infrared Ranging and similar triangles are applied to measure the distance between the surrounding objects and DEEBOT. When the sensor detects an object nearby, DEEBOT will automatically take a turn to avoid bumping into the object. The detection range is 0.3 m.   |
| Anti-drop Sensors         | Using the Time-of-Flight (dToF) principle, the dToF sensor located on DEEBOT's bottom continuously measures the distance between DEEBOT and the ground. Meanwhile, infrared sensors on the bottom detect the distance using infrared ranging technology. DEEBOT will not move forward when there are stairs in front (such as when the height of the white surface is 55 mm or more, or the height of the black surface is 30 mm or more) and the identified height exceeds the preset one, realizing the anti-drop feature. |
| Carpet Detection Sensor   | The sensor emits 300 kHz ultrasound, whose energy will be absorbed by the carpet, causing the echoed energy to be lower than the threshold. DEEBOT thereby detects the carpet's presence. In the ECOVACS laboratory, more than 50 types of carpets available on the market are identified.   |
| Anti-collision Sensor     | With the principle of the Optocoupler Switch, DEEBOT will avoid obstacles when they are about to collide.  |
| Edge Sensor               | With Infrared Ranging, the edge sensor detects the distance between the DEEBOT and objects on the side. When there is a wall or obstacles on the right, the DEEBOT performs edge cleaning to avoid missing any spots and prevent collisions.   |
| AIVI Camera               | AI intelligent analysis is utilized for environmental sensing and efficient video management (for some models).  |
| Microphone                | The microphone captures sound through diaphragm vibrations caused by the human voice traveling through the air. This enables voice recording and Voice Control to direct the DEEBOT to complete the assigned job through the acquisition and algorithms of sound models. The effective wake distance is 5 m.   |
| Infrared Stain Sensor     | Using infrared lighting, DEEBOT detects particles and liquid dirt within 40 cm of the ground and implements intelligent cleaning strategies.   |

# INITIAL SETUP AND USE

## 1 Notes before Cleaning



### Tidy up the Area to be Cleaned

For the maximum cleaning area possible, put furniture, such as tables, chairs, and pedestal fans, in their proper place and put away low-lying items, such as weight scales, before using DEEBOT.

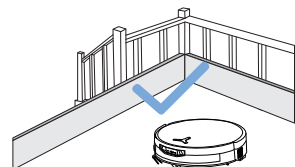

### Prevent DEEBOT from Falling

Place a physical barrier at the edge of a drop, such as staircases and steps, to stop DEEBOT from falling over the edge.

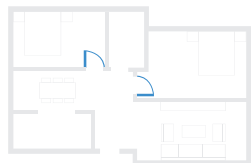

### Open Doors and Help DEEBOT Explore

Open all room doors to help DEEBOT fully explore your house during the first use.



Remove objects, including cables, clothes, and slippers, from the floor to improve cleaning efficiency.



Before using the product on a carpet with tasseled edges, please fold the tassels under the carpet.



Please do not stand in narrow spaces, such as hallways, to avoid blocking the navigation module.



Ensure the clarity of DEEBOT's vision and avoid scratching or smudging the Obstacle Avoidance Module lens with fingerprints or oily stains. Use a clean, soft cloth to wipe the camera, instead of cleaning agents, detergents, or sprays.

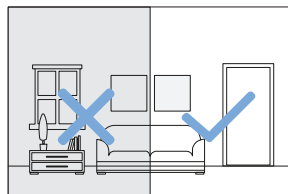

### Provide Sufficient Lighting

Ensure all cleaning areas are well-lit to support DEEBOT's Obstacle Avoidance Module in accurately avoiding obstacles such as shoes, socks, and cords.

## 2 Quick Start

Remove all protective materials before using the appliance.

### 1. Station Installation

The sound of "click" indicates proper installation.

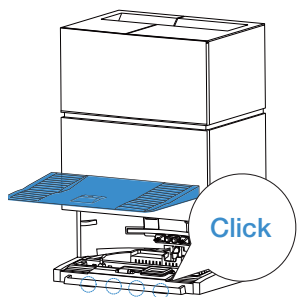

### 2. Assemble and Place the Station

Place the OMNI station against the wall on a flat, hard surface. Do not place items within 0.05 m on either side and 0.8 m in front.

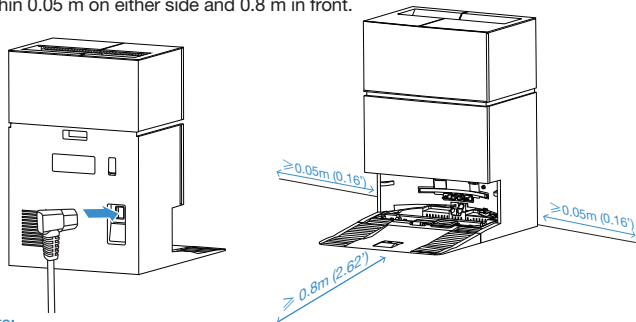

#### Note:

- If there are reflective objects such as mirrors and reflective skirting lines near the station, the bottom 14 cm of such objects should be covered.
- Do not place the station under direct sunlight or in high-temperature environments.
- Place the station in a location with a strong Wi-Fi signal for a better user experience.

## 3 Download ECOVACS HOME APP

To enjoy all available features, it is recommended that you control your DEEBOT via the ECOVACS HOME App.

Scan the QR code under the top cover to download the ECOVACS HOME App.

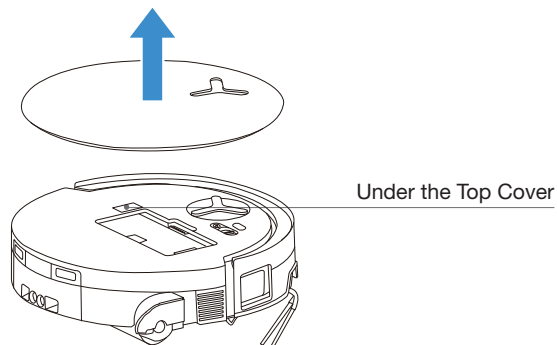



Or search "ECOVACS HOME" on the App Store or Google Play to download the ECOVACS HOME App.



Note: Follow the instructions on the App to complete the registration, login, and connection.

## 4 Connect DEEBOT with APP

**Via Bluetooth:** Turn on DEEBOT and your mobile phone Bluetooth. Allow the App to obtain mobile phone Bluetooth permission. Tap to scan the QR Code on DEEBOT or tap  or  in the App to find the nearby DEEBOT.

**Via Wi-Fi:** You can also choose to connect DEEBOT with the App through other methods according to the prompts on the App's page.

**Note:** Please connect via Bluetooth for a better experience.

**Note:** Please connect via Bluetooth for a better experience.

### Wi-Fi Network Requirements:

- You are using a 2.4GHz or 2.4/5 GHz mixed network.
- Your router supports 802.11b/g/n and IPv4 protocol.
- Do not use a VPN (Virtual Private Network) or Proxy Server.
- Do not use a hidden network.
- WPA and WPA2 using TKIP, PSK, AES/CCMP encryption.
- WEP EAP (Enterprise Authentication Protocol) is not supported.
- Use Wi-Fi channels 1-11 in North America and channels 1-13 outside North America (refer to local regulatory agency).
- If you are using a network extender/repeater, the network name (SSID) and password are the same as those of your primary network.
- Please enable the WPA2 on your router.

### Wi-Fi Indicator Light

|   |                           |                         |
|---|---------------------------|-------------------------|
|  | Slow flashing white light | Disconnected from Wi-Fi |
|   | Fast flashing white light | Connecting              |
|   | Steady white light        | Connected to Wi-Fi      |

Please be aware that intelligent features such as remote startup, voice interaction, 2D/3D map display and control settings, and personalized cleaning (depending on the Appliance) require the ECOVACS HOME App, which is constantly updated.

You need to agree to our Privacy Policy and User Agreement so that we can process some of your essential and necessary information before you can use certain features of the ECOVACS HOME App to control the Appliance. If you disagree with our Privacy Policy and User Agreement, such features will be unavailable. However, you can still use the basic features of this appliance for manual operation.

### Network Interface Information

| Name               | Description  |
|--------------------|--|
| Infrared interface | The infrared interface is turned off by default, and it is activated when DEEBOT is in the charging station. When the DEEBOT is in the charging station, it will communicate with the charging station through the infrared interface. |
| Bluetooth          | Enable Bluetooth to connect the robot to the network during the network setup process. Bluetooth uses the GAP1800, GATT 1801, 8888 service for configuration and data interaction securely.  |
| Wi-Fi*             | Facilitate data transfer between the app and DEEBOT, enabling control of DEEBOT through the app.   |
| ECOVACS HOME App   | ECOVACS products offer smart functions such as network setup, mapping, and cleaning mode selection (specific to each product). To utilize these features, users need to download and use the official ECOVACS Home App.                |

\* The DEEBOT series robotic vacuums are designed for domestic cleaning scenarios. A home Wi-Fi network is required for operation, and anti-DDOS protection needs to be configured by users through route settings.

## 5 Power on and Charge DEEBOT

Turn on the power switch under DEEBOT's cover ('I' = ON, 'O' = OFF), and place DEEBOT in front of the station that is connected to the power supply. Use the App or voice control to recall DEEBOT, or press and hold  on DEEBOT for 3 s, to allow DEEBOT to dock for charging.

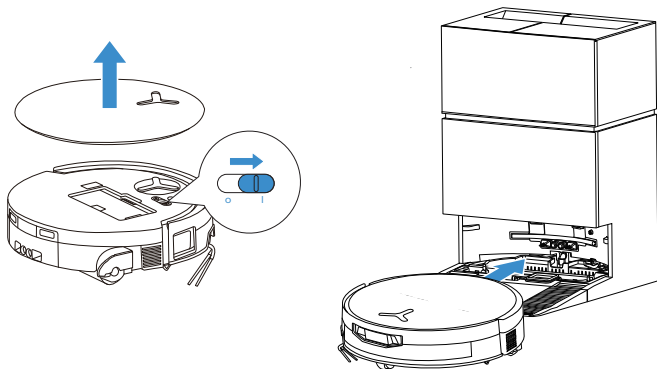

### Note:

- DEEBOT cannot charge when it is powered off.
- After cleaning, it is recommended to keep DEEBOT powered on and charging to ensure it is ready for the next cleaning session.
- Please start cleaning from the station. Do not move the station while cleaning.

## 6 Fill the Clean Water Tank

Take out the clean water tank, open the tank cover, and fill the tank with water. Close the tank cover and reinstall the clean water tank.

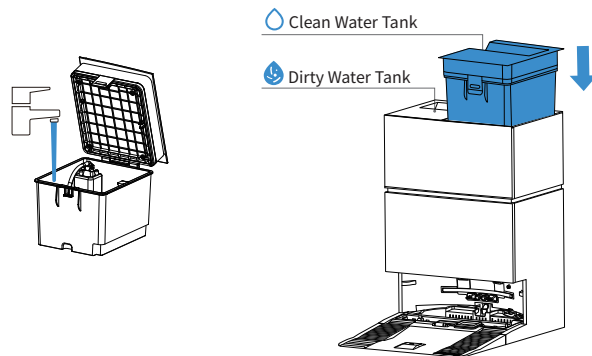

### Note:

- Use only ECOVACS DEEBOT cleaning solution to avoid malfunctions.
- Use a clean, dry cloth to wipe off any water on the surface of the tank before placing it in position.
- Make sure to lock the top covers of both water tanks securely before use.
- Any watermarks in the water tanks are from function testing. Please use it with confidence.

## 7 Add Cleaning Solution

1. Take off the dust collection cabin cover, pull out the two cleaning solution boxes, and place them on a level, hard surface.

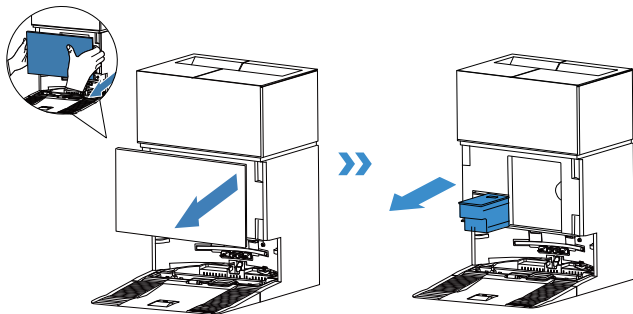

2. Pour the cleaning solution into the blue box and the heavy-duty cleaning solution into the black box. After securing the box lids, push them back into the station and close the tank lid.

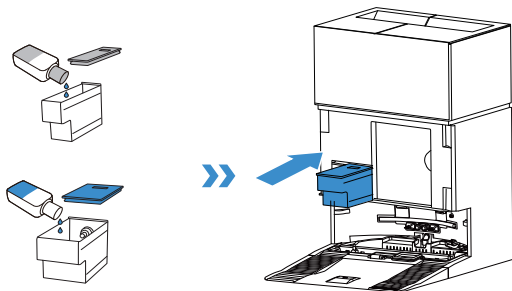

### Note:

- Do not pour cleaning solution into the clean water tank. Add it to the cleaning solution tank instead. Otherwise, an incorrect ratio may cause excessive foaming and reduce cleaning effectiveness.

3. Return the dust collection cabin cover and press the cover firmly to secure it in position.

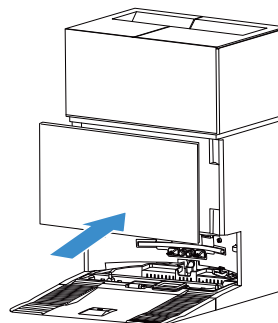

### Note:

- Do not overfill with cleaning solution, as it may overflow when the lid is secured. This step can be skipped if you do not use floor cleaning solution regularly and the Auto Cleaning Solution Dispense function can be disabled in the APP.
- For better performance and longer lifespan of the product, please use ECOVACS DEEBOT cleaning solution.
- Please make sure that no foreign objects fall into the cleaning solution box.

## 8 Operate DEEBOT for Cleaning

### 1. Start Mapping

Before the first mapping, please help eliminate a few potential issues. For example, DEEBOT may get stuck under furniture. Please refer to the following solutions:

- ① Raise the low-sitting furniture if possible;
- ② Cover the bottom of the furniture;
- ③ Set up a virtual boundary via the App.

### 2. Start Cleaning

- The DEEBOT's water tank is automatically refilled through the station. Manual refilling is not needed.
- When mopping, DEEBOT will recognize floor types and is able to lift mops automatically when encountering carpets. Please do not use DEEBOT on shaggy rugs or carpets. It is recommended to fold up the shaggy rugs during the cleaning process, or set the carpeted area as a no-entry zone by setting a virtual boundary in the App.

Please ensure that DEEBOT is in the station and is fully charged before cleaning for the first time. Tap  on DEEBOT to start. You can also use the ECOVACS HOME App or voice control to start.

### 3. Pause

Tap  on DEEBOT to pause it while it is working. You can also use the ECOVACS HOME App or voice control to pause DEEBOT.

### 4. Wake Up

After pausing for a while, all indicator lights on DEEBOT will go out. To wake up DEEBOT, press .

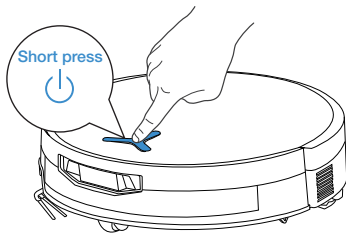

### 5. Back to Station

Use the ECOVACS HOME App or voice control to recall DEEBOT, or press and hold the  button on DEEBOT for 3 s, to allow DEEBOT to dock for charging.

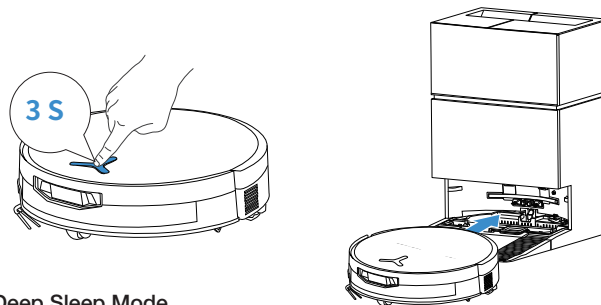

### 6. Deep Sleep Mode

DEEBOT will enter deep sleep mode if it stays outside the station for about 10 h to protect the battery. Please switch OFF and ON to wake DEEBOT up.

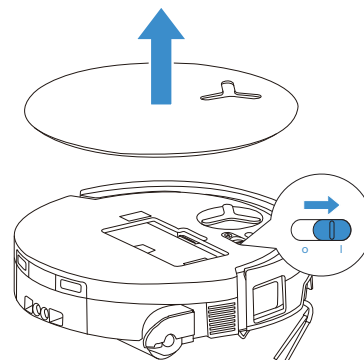

When DEEBOT returns to the station during a task, PowerBoost Charging will start by default and take approximately 5 minutes. It will then switch to standard charging and stop automatically once fully charged.

## REGULAR MAINTENANCE

### ① Maintenance Frequency

To keep DEEBOT running at peak performance, perform maintenance and replace parts at the following frequencies:

| Part  | Maintenance Frequency | Replacement          |
|---|-----------------------|----------------------|
| Replaceable Roller  | /                     | Every 1-2 months     |
| Drip Tray   | Every week            | /                    |
| Dust Bag  | /                     | When the App prompts |
| Side Brush  | Every 2 weeks         | Every 3-6 months     |
| Main Brush  | Every week            | Every 6-12 months    |
| Filter  | Every week            | Every 3-6 months     |
| Edge Sensor<br>Universal Wheel<br>Anti-drop Sensors<br>Bumper<br>Charging Contacts on DEEBOT<br>Charging Contacts on OMNI Station<br>Navigation Module<br>Obstacle Avoidance Module | Approx. every month   | /                    |
| Clean Water Tank  | Every 3 months        | /                    |
| Dirty Water Tank  | Every month           | /                    |
| Body and Bottom of the Station  | Every month           | /                    |
| Mop Washing Tray  | Every 5 months        | /                    |
| Cleaning Solution Unit  | Every month           | /                    |

**Note:** Explore more accessories at the ECOVACS HOME App or at <https://www.ecovacs.com>.

## DEEBOT MAINTENANCE

### ① Maintain Dust Bin and Filter

1. Remove the dust bin and then empty it.

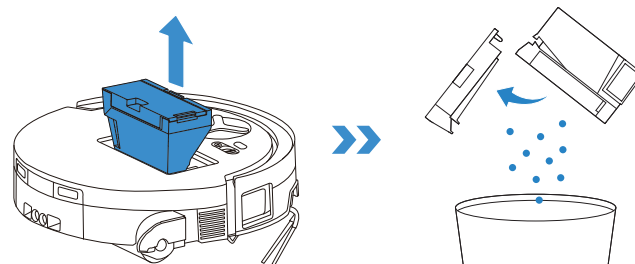

2. Open the filter net and remove the filter.

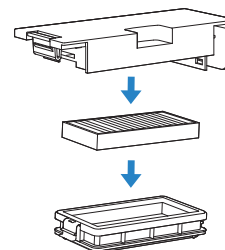

3. Rinse the dust bin and filter with water, and shake off the water droplets.

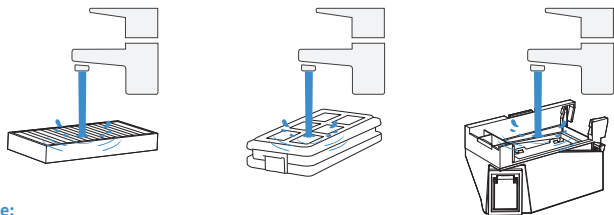

**Note:**

- Please rinse the filter with water as shown.
- Do not use fingers or brushes to clean the filter.

4. Air-dry the dust bin and filter.

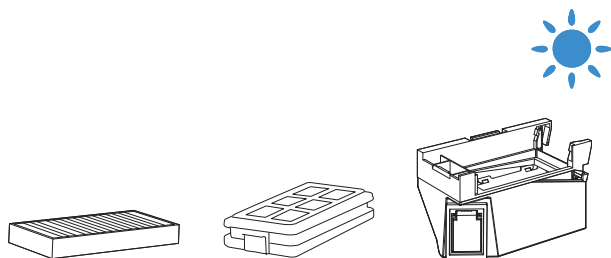

**Note:** Completely dry the components before use.

## 2 Maintain Main Brush and Side Brush

### Clean the Main Brush.

1. Remove the cover from the main brush.

**Note:** Before turning DEEBOT upside down, please empty any remaining water from the drip tray.

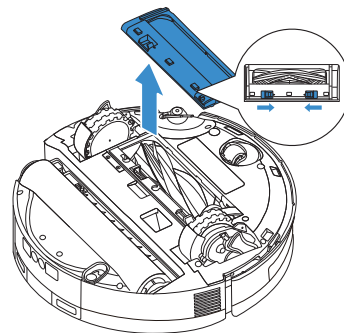

2. Remove and clean the main brush and its chamber.

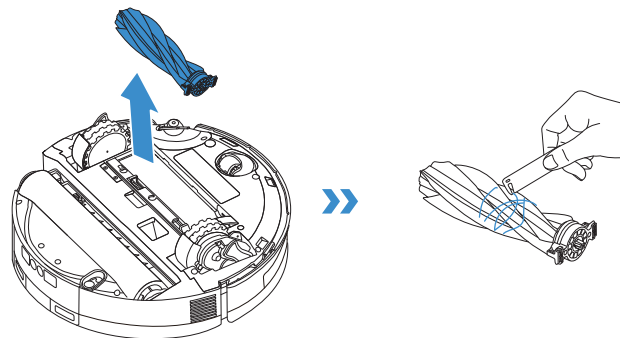

4. Install the main brush and the cover.

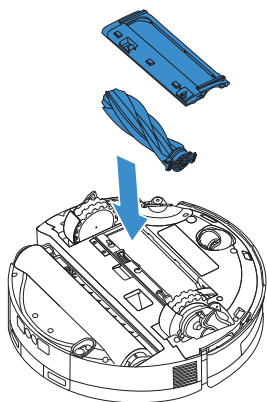

### Clean the Side Brush

Remove the side brush using a screwdriver and clean it.

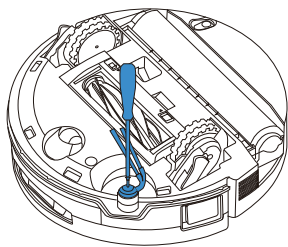

### 3 Maintain Roller Components

1. Press the roller release button on the side of the roller mop, gently lift, and remove the roller mop.

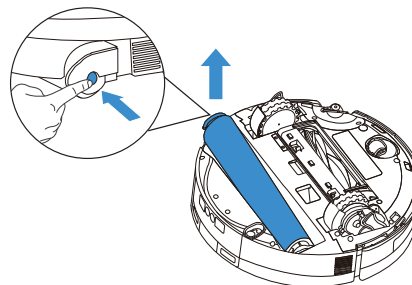

2. Remove the roller end cover, clean and dry the roller mop. Wipe the roller chamber with a damp cloth that has been wrung out.

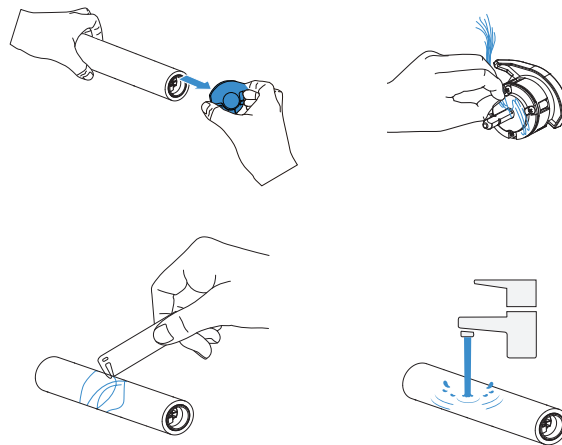

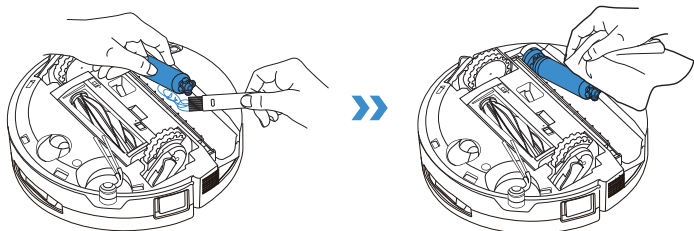

**Note:**

- Do not pull roller motor components forcefully during cleaning to avoid damage.
- Do not rinse DEEBOT with water.

3. Reinstall the roller end cover and attach the roller mop to the motor. Once the mop is in place, align the roller release button with the groove on the side of the roller chamber and press it. A "click" sound indicates the mop is properly installed.

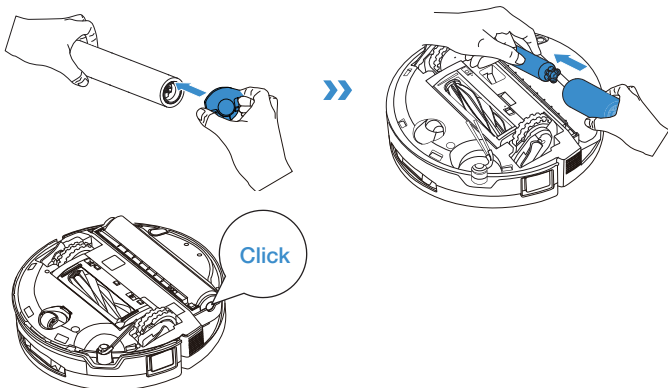

**Note:** Explore more accessories at the ECOVACS HOME App or at <https://www.ecovacs.com>.

#### 4 Maintain Drip Tray

1. Push up the release button to remove the drip tray, then clean and dry it.

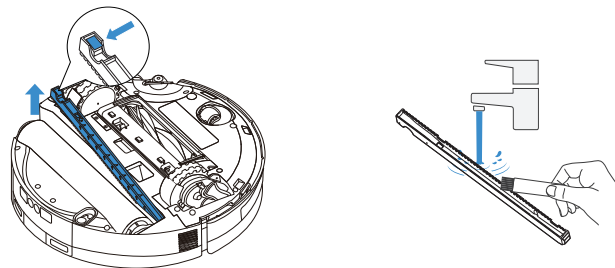

**Note:** A small amount of residual water may leak out when flipping DEEBOT if it's not in drying mode.

2. Reinstall the drip tray and press down firmly until it's properly installed.

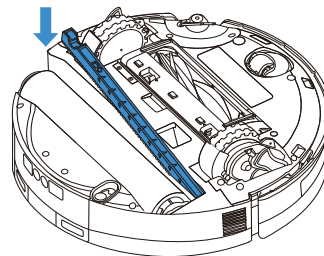

## 5 Clean Mop Roller Cover

1. After removing the roller mop, slide the mop roller cover release switch to the right to unlock it.

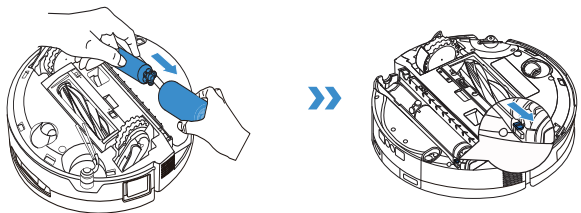

2. Grip the mop roller cover by the groove on the roller chamber, then gently twist and lift it off.

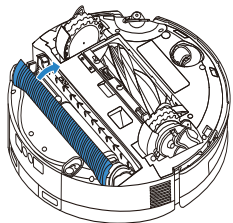

3. Once the mop roller cover is cleaned and dried, align its axle with the track on the left side of the roller chamber, reinstall it, and lock the release switch.

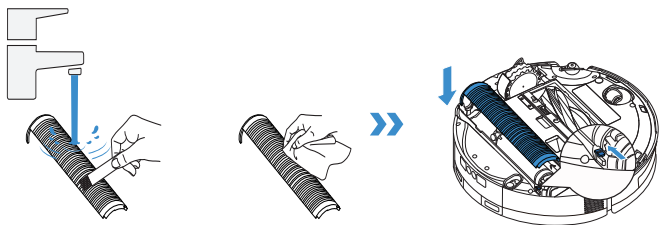

## 6 Maintain Other Components

### Clean the Obstacle Avoidance Module Lens

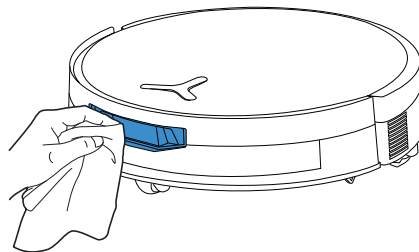

### Clean the Bumper

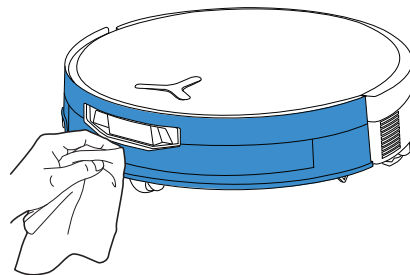

## Clean the Navigation Module

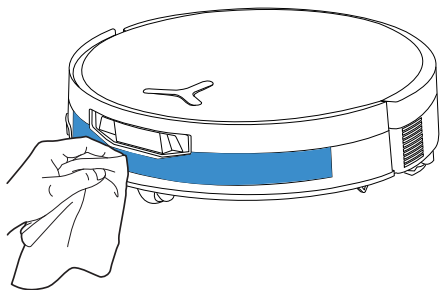

## Clean the Edge Sensor

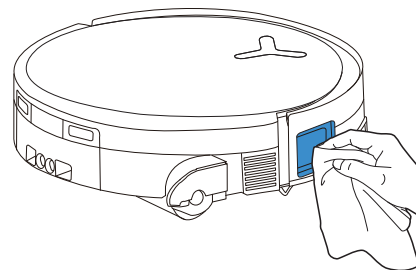

## Clean Charging Contacts

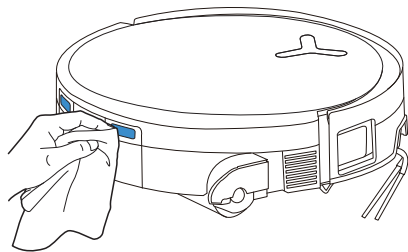

## Clean the Anti-drop Sensors

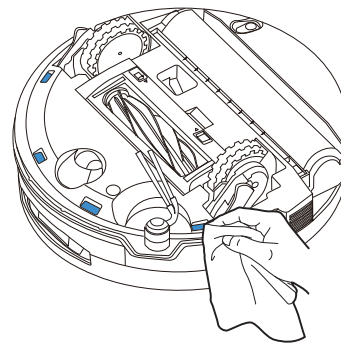

### Note:

- Wipe the components with a clean, dry cloth. Never use a wet cloth. Do not use cleaning sprays or detergents, as moisture may cause damage.
- Charging contacts contain sensitive electronic components. Clean them with a dry cloth. Do not use a wet cloth to prevent water damage.

## Clean the Universal Wheel

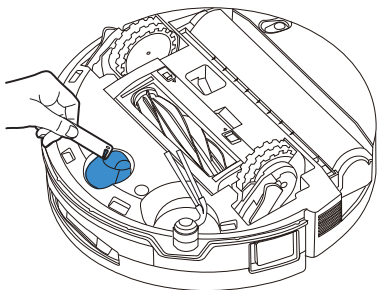

## Clean the Driving Wheels

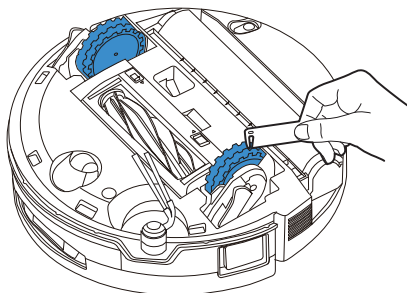

## STATION MAINTENANCE

### 1 Maintain Dust Bin

1. Remove the dust collection cabin cover.

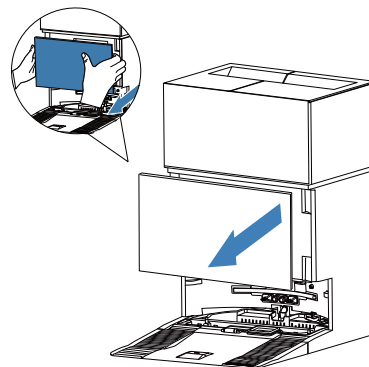

2. Remove the disposable dust bag in the direction of the arrow and discard it.

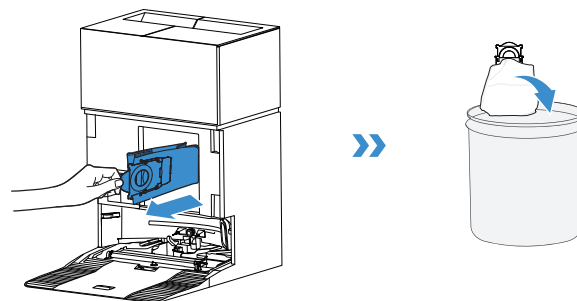

**Note:** Hold the handle to lift out the dust bag, which can effectively prevent dust leakage.

3. Clean the dust container with a dry cloth and install a new dust bag.

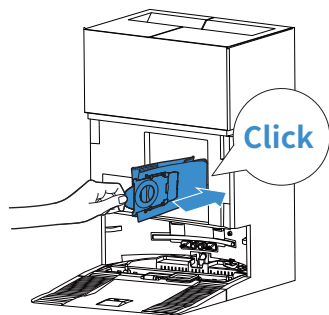

4. Insert the top latch of the dust container cover into the slot, and then press downward to ensure a proper seal.

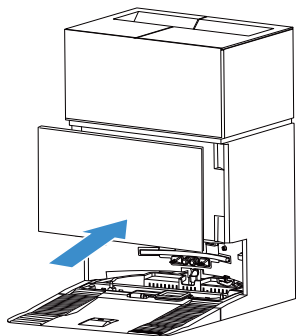

## 2 Maintain Mop Washing Tray

1. Remove and clean the station base.

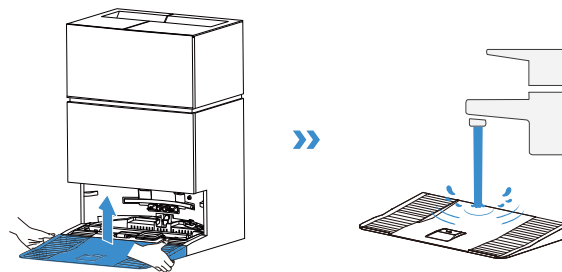

2. Remove the mop washing tray. Press the latch on the tray to detach the filter and clean it.

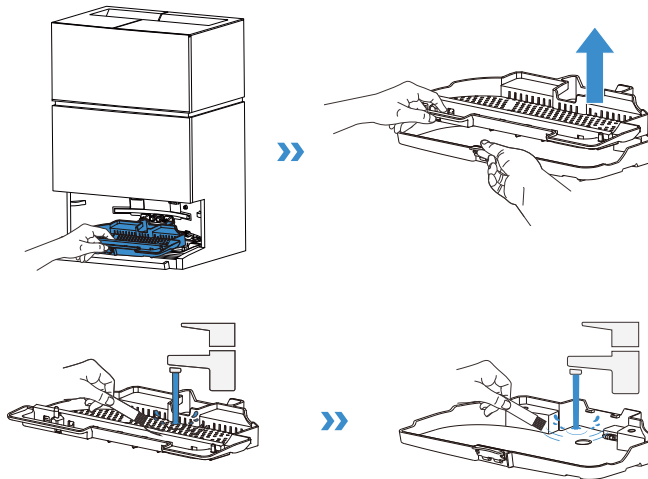

3. Reinstall the mop washing filter, tray, and station base in order. A "click" sound indicates they are securely in place.

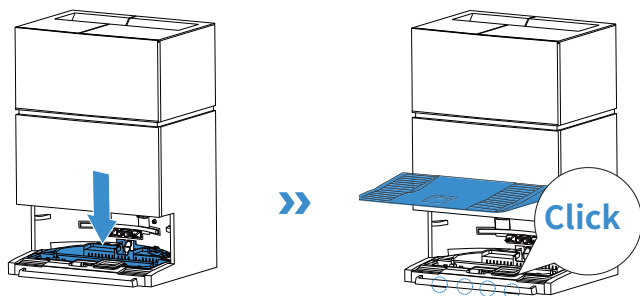

**Note:** Please install the tray and base properly to prevent malfunction.

#### 4 Storage

Please fully charge and switch OFF DEEBOT before storage. Please recharge it every 1.5 months to prevent the battery from over-discharging.

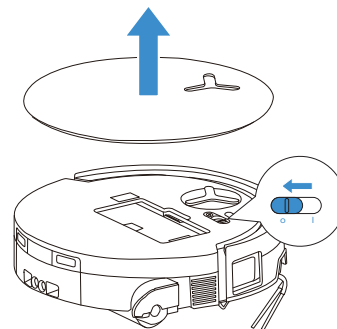

**!** Please note that DEEBOT cannot charge when powered OFF.

**Note:**

- After DEEBOT finishes its cleaning task, it is recommended not to power it off but to keep it charging, to better prepare for the next cleaning session.
- If the battery is over-discharged or not used for a long time, DEEBOT may not be charged. Please contact ECOVACS for help. Do not disassemble the battery by yourself.
- If you do not use DEEBOT for a long time, use the Device Relocation feature in the App to drain the clean water inside DEEBOT, keep the station water tanks empty, and the roller mops dry.

# TROUBLESHOOTING

For the following possible issue, refer to the corresponding solutions.

| No. | Malfunction  | Possible Cause   | Solution  |
|-----|--|--|---|
| 1   | DEEBOT is not able to connect to the ECOVACS HOME App. | Incorrect Wi-Fi username or password entered.  | Enter the correct Wi-Fi username and password.  |
|     |  | DEEBOT is not within range of your home Wi-Fi signal.  | Make sure DEEBOT is within range of your home Wi-Fi signal. Try to stay as close to the router as possible.   |
|     |  | DEEBOT is not in the configuration state.  | Press the Reset button to connect DEEBOT to your phone by Bluetooth. If it fails, please press the Reset button +  and connect via the ECOVACS HOME App. |
|     |  | There is no home Wi-Fi on the Wi-Fi list.  | Check if the Wi-Fi name contains special characters. Please do not use special characters like ! @#& ¥%/\.<br>Do not use a 5 Ghz network.   |
|     |  | An incorrect App is installed.   | Please download and install the ECOVACS HOME App.   |
| 2   | Unable to create the furniture map in the App.         | Moving DEEBOT when cleaning might cause the map to be lost.  | During cleaning, do not move DEEBOT.  |
|     |  | Auto cleaning is not finished.   | Make sure DEEBOT automatically returns to the OMNI Station after cleaning.  |
|     |  | Multi-floor mode was not enabled when the second map was created.                                      | Please enable multi-floor mode in the App.  |
| 3   | The side brush drops out of place during use.          | The side brush is not properly installed.  | When installing the side brush with a screwdriver, ensure the screw is tightened securely.  |
| 4   | No signal found. Unable to return to the station.      | The OMNI Station is incorrectly placed.  | Place the station properly according to the instructions in the <a href="#">[Power on and Charge DEEBOT]</a> section.   |
|     |  | Station is out of power or has been moved.   | Check whether the OMNI Station is connected to the power supply. Do not move the OMNI Station.  |
|     |  | DEEBOT does not start cleaning from the OMNI Station.  | It is recommended that DEEBOT start cleaning from the OMNI Station.   |
|     |  | The docking route is blocked. For example, the door is closed to the room where the station is placed. | Keep the charging route clear.  |

| No. | Malfunction   | Possible Cause   | Solution   |
|-----|---|--|--|
| 5   | DEEBOT returns to the OMNI Station before it has finished cleaning. | The room is so large that DEEBOT needs to return to recharge.  | Please enable auto resume. For more details, please follow the App instructions.   |
|     |   | In highly complex home layouts, cleaning efficiency may decrease, possibly resulting in incomplete cleaning. | Simplify your home layout.   |
| 6   | DEEBOT is unable to charge.   | DEEBOT is not switched ON.   | Switch ON DEEBOT.  |
|     |   | DEEBOT's charging contacts are not connected to the OMNI station's charging contacts.                        | Make sure that DEEBOT's charging contacts have connected to the station's charging contacts and  flashes. Check whether DEEBOT's and OMNI station's charging contacts are dirty. Please clean these parts according to the instructions in the <a href="#">[REGULAR MAINTENANCE]</a> section. |
|     |   | The OMNI Station is not connected to the power supply.   | 1. Make sure the OMNI station is connected to power supply.<br>2. Once the power is connected, ensure that the motor startup sound can be heard.   |
|     |   | The base has not been installed in place.  | Refer to the <a href="#">[Quick Start]</a> section for correct installation.   |
| 7   | DEEBOT is very loud during cleaning.                                | The main brush/side brush/roller mop is tangled, or the dust bin is blocked.                                 | It is recommended to clean the main brush, side brush, dust bin, roller mop, etc., regularly.  |
|     |   | DEEBOT is in Strong Suction Mode or Max Suction Power Mode.  | Switch to Standard or Quiet Mode. Quiet Mode may reduce cleaning performance.  |
| 8   | DEEBOT gets stuck while working and stops.                          | DEEBOT is tangled with objects on the floor (electrical wires, curtains, carpet fringing, etc.).             | DEEBOT will try various ways to free itself. If its attempts fail, manually remove the obstacles and restart.  |
|     |   | DEEBOT might be stuck under furniture with an entrance of similar height.                                    | Please raise the furniture, set a physical barrier, or set a virtual boundary via the ECOVACS HOME App.  |
|     |   | DEEBOT is stuck in a narrow area.  | Tidy up your home, set a physical barrier, or set a virtual boundary via the ECOVACS HOME App.   |

| No. | Malfunction  | Possible Cause   | Solution  |
|-----|--|--|---|
| 9   | During cleaning, DEEBOT may encounter issues like a disorderly route, biased movement, repeated cleaning over the same spots, and missing small areas. | A large area has not been cleaned, possibly because it was blocked.  | Ensure the door is open, clear potential obstacles, such as slippers and scattered cords. DEEBOT will perform supplementary cleaning before the cleaning session is finished.                             |
|     |  | The driving wheels may slip on the ground when DEEBOT climbs steps, thresholds, and door bars, which can affect its judgment of the entire home environment. | Close the door of the room, or set a virtual boundary in the App. You can then bring DEEBOT into the room to clean it separately.   |
|     |  | On freshly waxed or polished floors, as well as smooth tiles, there may be less friction between the driving wheels and the floor.                           | Please wait for the wax to dry before cleaning.   |
| 10  | After returning to the OMNI station, DEEBOT does not empty its dust bin.   | The Auto-Empty function has not been turned on in the App.   | Turn on the Auto-Empty function in the App.   |
|     |  | Manually moving DEEBOT back to the station will not trigger the Auto-Empty function.   | It is recommended to allow DEEBOT to return to the OMNI Station on its own. Please do not manually move it.   |
|     |  | In Do Not Disturb mode, DEEBOT will not empty the dust after returning to the OMNI Station.  | Turn off Do Not Disturb in the App or manually start dust-emptying.   |
|     |  | The station detects a decrease in empty efficiency.  | Replace the dust bag according to the <a href="#">[REGULAR MAINTENANCE]</a> section and close the dust collection cabin. If the dust bag is not full when prompted by the App, you can put it back again. |
|     |  | Check if the dust bin is full and causes a blockage.   | Clean the dust bin according to the <a href="#">[REGULAR MAINTENANCE]</a> section.  |
|     |  | If the above possible causes have been ruled out, components of the station may be abnormal.   | Please contact customer service for assistance.   |

| No. | Malfunction   | Possible Cause  | Solution  |
|-----|---|---|---|
| 11  | Auto-Empty unsuccessful.                              | The station detects a decrease in empty efficiency.   | Please replace the dust bag according to the <a href="#">[REGULAR MAINTENANCE]</a> instructions and securely close the dust collection cabin door. If the replacement prompt appears but the bag is not full, remove, reinsert, and then properly secure the cabin. |
|     |   | The outlet of the dust bin is blocked by foreign objects.   | Remove the dust bin and clear the foreign objects on the outlet.  |
| 12  | The inner side of the dust collection cabin is dirty. | Fine particles pass through the dust bag and accumulate on the inner side of the dust collection cabin. | Clean the inner side of the dust collection cabin.  |
|     |   | The dust bag is broken.   | Check and replace the dust bag.   |
|     |   | The dust bag is not properly installed.   | Please install the dust bag properly.   |
|     |   | The dust container cover is not closed.   | Please check if the dust container cover is closed properly.  |
| 13  | Dust leakage occurs while DEEBOT is working.          | The outlet of the dust bin is blocked by foreign objects.   | Remove the dust bin and clear the foreign objects on the outlet.  |
| 14  | The roller mop does not rotate.                       | The roller mop is not correctly installed.  | Install the roller mop properly according to the <a href="#">[REGULAR MAINTENANCE]</a> section.   |
|     |   | The roller mop is blocked by foreign objects.   | Clean and install the roller mop properly according to the <a href="#">[REGULAR MAINTENANCE]</a> section.   |
| 15  | The driving wheel is stuck.                           | The driving wheel is entangled or stuck due to foreign objects.   | Rotate and press the driving wheel to check for any wrapping or obstruction by foreign objects. If any foreign objects are found, please clean them promptly. If this issue persists, please contact customer service for assistance.                               |

| No. | Malfunction   | Possible Cause   | Solution   |
|-----|---|--|--|
| 16  | The mop washing tray is full of water and cannot be emptied. A voice prompt reports the mop washing tray malfunction. | The dirty water tank is not properly installed.  | Tap down on the dirty water tank to ensure it is properly installed.   |
|     |   | The sealing plugs in the dirty water tank are not installed properly.                      | Make sure that the two sealing plugs are properly installed.   |
|     |   | The mop washing tray is not properly installed.  | Check and ensure the mop washing tray is properly installed.   |
|     |   | Check if the floating ball gets stuck when there is no water in the mop washing tray base. | Take out the mop washing tray to put the floating ball back in place.  |
|     |   | The OMNI Station cannot drain water normally.  | Place DEEBOT in the station. After ensuring it's charging, double tap  . If the issue persists, please contact customer service for assistance. |
|     |   | The suction port of the mop washing tray is blocked by foreign objects or dirt.            | Please clean the mop washing tray and its filter, and make sure the inlet is free of any foreign objects.  |
|     |   | The voice alert persists after all the above solutions are tried.                          | Power off and on the station. If this issue persists, please contact customer service for assistance.  |

**Please contact our customer service for assistance if the problem persists despite the recommended solutions.**

## TECHNICAL SPECIFICATIONS

|                                |                      |                                 |                   |
|--------------------------------|----------------------|---------------------------------|-------------------|
| <b>Model</b>                   | <b>DEX35</b>         |                                 |                   |
| Rated Input                    | 17.8 V === 2 A       | Fast Charge Input               | 16.4 V === 10.5 A |
| Charging Time                  | about 4.5 h          |                                 |                   |
| <b>Station Model</b>           | <b>CH2542</b>        |                                 |                   |
| Rated Input                    | 110-120 V ~ 50-60 Hz |                                 |                   |
| Nominal Charge Output          | 17.8 V === 2 A       | Fast Charge Output (Short Time) | 16.4 V === 10.5 A |
| Rated Input Current (Charging) | 3 A                  | Power (Emptying)                | 4.5 A             |
| Power (Hot Water Washing Mop)  | 4A                   |                                 |                   |

Output power of the wireless module is less than 100 mW.

Note: Technical and design specifications may be changed for continuous product improvement.

Explore more accessories at <https://www.ecovacs.com>.

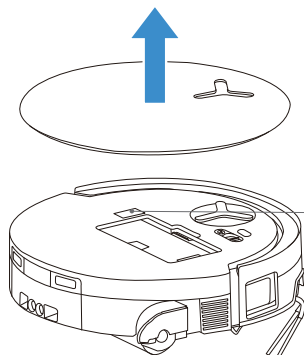

Please use the mobile camera to scan the QR code and obtain the user guide.