

CUJO Setup Guide



Table of Contents

[Package Contents](#)

[CUJO Device](#)

[CUJO App](#)

[Setup Introduction](#)

[Connect Your CUJO](#)

[Option 1: Direct Connection](#)

[Option 2: Bridged Connection](#)

[Firmware Update](#)

[Compatibility](#)

[DHCP Mode](#)

[Network Setup Examples](#)

[Option 1: Router → devices](#)

[Option 2: Router → “Bridge mode only” router → devices](#)

[Option 3: Router → Access Point | Switch → devices](#)

[Option 4: Router → device + “Bridge mode only” router | Access Point | Switch → devices](#)

[Option 5: “Bridge mode only” router → devices](#)

[Option 6: “Unconfigurable ISP Router” → devices](#)

[Option 7: “Unconfigurable ISP Router” → “Bridge mode only” router → devices](#)

[Option 8: “Unconfigurable ISP Router” → Access Point | Switch → devices](#)

[Advanced network example](#)

[CUJO Specification](#)

[Legal Notice](#)

[Declaration](#)

Package Contents



The CUJO package (no. 1) contains the following:

- CUJO device (no. 2)
- Power adapter (no. 3) - to connect the CUJO device to a power source.
The adapter is compatible with 100-240V 50-60Hz power.
It also comes with an appropriate power plug based on your location.
- Ethernet cable (no. 4) to connect CUJO to your router (length: 3 feet / 1 meter)
- Information card with the MAC address of the CUJO device and a link to the online instruction page

CUJO Device



Back view of the CUJO device:

- Pin hole for the reset button (no. 1)
- Top port (no. 2) for Bridge mode. The CUJO device expects to find an access point or switch connected to this port. It also works with routers set to “Bridge mode” (like Apple AirPort, Eero, OnHub, Google WiFi and etc.)
- Bottom port (no. 3) to connect to an internet source. CUJO expects to find a router connected to this port.
- Power socket (no. 4) for the power cord

CUJO App



Before you proceed to set up CUJO as a security device for your network, please download the CUJO app for your mobile device. Supported devices:

- Apple devices (iPhone, iPad). Minimum iOS v. 8.4.1, screen 640x960
- Android devices (phones and tablets). Minimum Android v. 4.1.1, screen 540x960

All configurations, controls, and notifications are handled using the CUJO app.

To keep CUJO itself secure, it only connects to the CUJO Cloud Service using an encrypted channel. The CUJO app and the CUJO device only communicate directly to the CUJO Cloud Service and there is no other interface to access the CUJO device.

You can download the app from the App Store or Google Play:



Setup Introduction

This document contains detailed instructions to set up your CUJO. The following is a short summary of the steps required:

- 1) CUJO App
 - *Download and install the CUJO app on your mobile phone (iOS or Android)*
 - *Open the CUJO app and sign up*
 - *Follow the step-by-step instructions on the CUJO app*
- 2) Connect your CUJO
 - *Take a look at the possible setup examples to decide on a way to connect your CUJO to your network*
- 3) Connect to the same network
 - *Connect your mobile device with the CUJO app installed to the same network as your CUJO device*
- 4) Activate
 - *Activate your CUJO device on the app and finish the setup*
- 5) Firmware update
 - *CUJO will detect the newest firmware version and will start an update if necessary*

Connect Your CUJO

There are two ways to connect your CUJO to your network:

- 1) Direct connection (**DHCP mode**) - CUJO is connected to the router as any other device. This mode needs configuration changes on your router.
- 2) Bridged connection (**Bridge mode**) - CUJO sits in between your router (upstream) and one of the following: a wireless access point, a network switch, or a another router. In bridge mode, there is no configuration change needed for your upstream device. There may be some configuration changes required on your downstream device. All devices connected to your downstream device are protected.

Option 1: Direct Connection

Connect your CUJO just like any other device to your router. Use the bottom Ethernet port on your CUJO and any open port on your router. Your router could be connected to a modem or it could be connected to a combo router + modem.

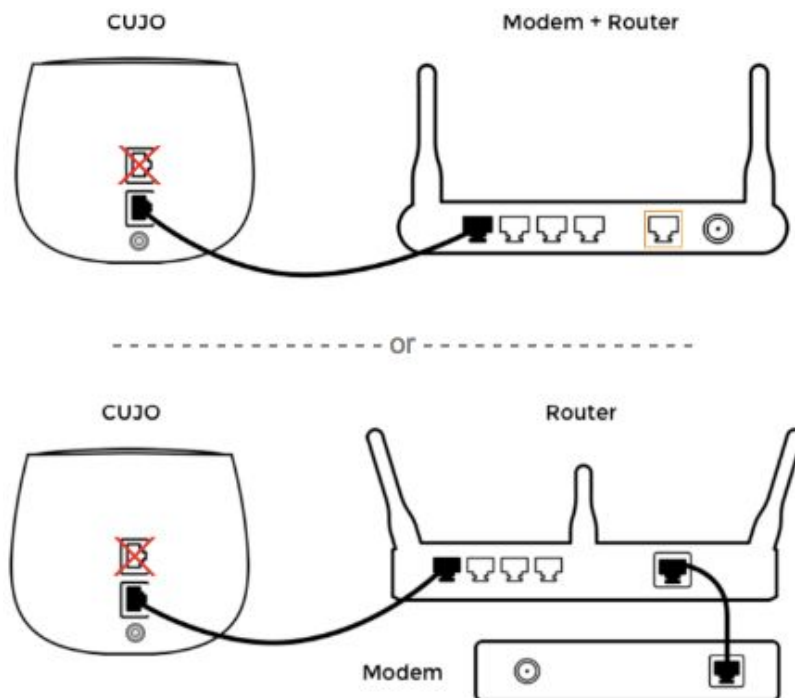

With a direct connection, your CUJO can operate in two modes:

DHCP mode. In this mode, CUJO will be running the DHCP server, but it requires disabling the DHCP server on your router. The CUJO app will help you change the DHCP settings automatically. Before the changes take place, we will ask you to provide login credentials for your router. Or you can choose to do it manually by following the step-by-step guide on your CUJO app or proceed further with this manual.

If you have any questions or difficulties with the setup, let us know. Our support team will be happy to help you. Contact us at hi@getcujo.com or 1-844-GET-CUJO.

Standby mode. In this mode, CUJO is just another device connected to your router, it does not protect your network. When CUJO is set in Standby mode, the CUJO support team will be happy to help you with the setup remotely. Contact us at hi@getcujo.com or 1-844-GET-CUJO.

* If you experience any connectivity issues, try switching to Bridge mode or call our support.

Option 2: Bridged Connection

If you have a router provided by your cable company (Comcast, AT&T, etc), but your connected devices are connecting to a switch, access point or another router (like the Apple Express or Google OnHub routers), then it's best to use this method.

Connect your cable company's router (the internet source) to bottom Ethernet port of your CUJO.

Connect your other access point or switch to the upper Ethernet port of your CUJO.

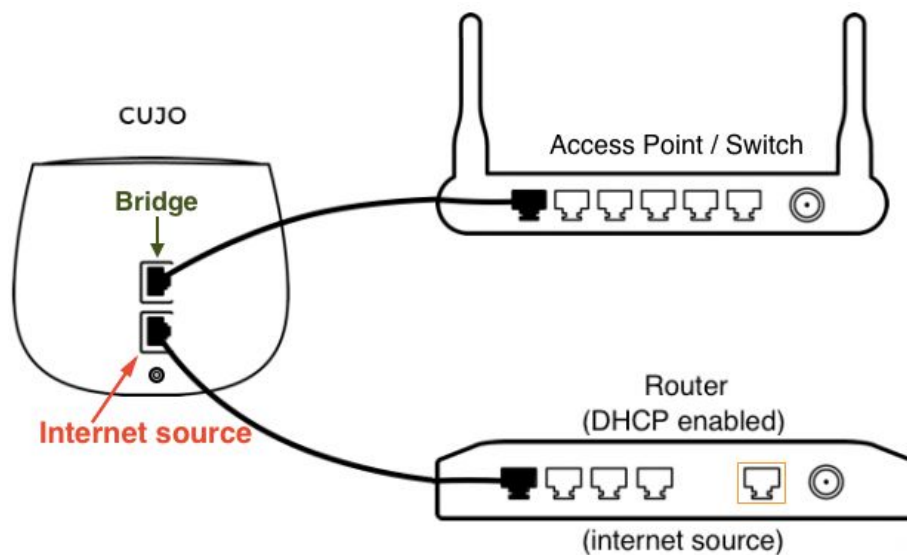

You can connect to a router instead of an access point or switch, but in that case you need an additional configuration of that router.

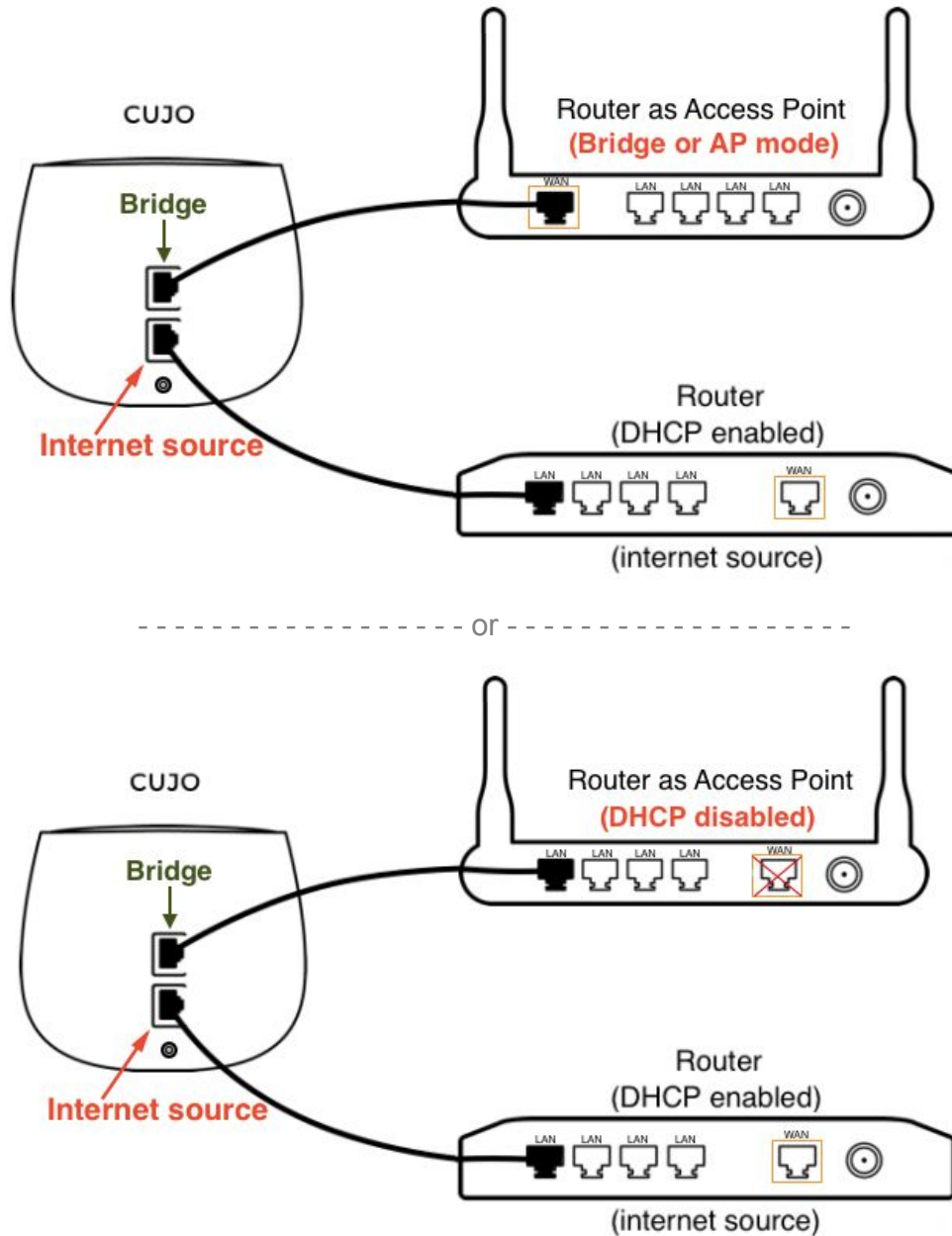

There are two ways to configure your router:

- Disable NAT and DHCP on your router. Usually, router manufacturers call it “Bridge” (“[Eero](#)”, “[Apple AirPort](#)”, “[OnHub](#)”), “Access Point” (AP) (“[Asus](#)”) or “Wireless Access Point” (“[Netgear](#)”) mode.
- If you are unable to turn off NAT functionality, you can turn off DHCP and plug your ethernet cable from the WAN port to the LAN port (“[TP-Link Archer](#)”).

Please see the article for [Compatibility](#)
To get more technical information refer to our [FAQ](#) page.



Make sure that the CUJO's eyes are up (smiling). If they are blinking fast, your firmware is being updated (see step 4 below). If the eyes are pointing down or not lit up at all, disconnect and reconnect your CUJO. If you are still having trouble, try an alternate connection method as shown above. If you are still having trouble, contact us at hi@getcujo.com or 1-844-GET-CUJO and we will walk you through the setup.

Firmware Update



If your CUJO's eyes are blinking fast it means that your firmware is being updated. Do not unplug your network or your CUJO when the eyes are blinking. You may lose Internet connectivity while the firmware is being updated. This should not take longer than 2-3 minutes. After the firmware updates itself, your CUJO's eyes will smile again.

Allow CUJO up to 48 hours to find and identify all devices on your network. Using the app, you can also edit each device and assign a name and model.

Compatibility

CUJO is compatible with all known routers in **Bridge mode** connected to CUJO's bottom port. In Bridge mode, you must also connect another device to CUJO's top port:

- **Access Point**
- **Switch**
- **Router** running in "Bridge mode" or "Access Point" (AP) or "Wireless Access Point" mode.

Also, you can make your router become a switch by:

- Disabling the DHCP server on your router
- Plugging the ethernet cable on your router from the WAN port to the LAN port

To connect CUJO in **DHCP mode**, the router must have the ability to turn off the DHCP server (or the ability to change the router's IP, please follow the exact steps on the app). Most routers are compatible with this configuration.

Known exceptions:

- *"Bridge mode only"* routers (incompatible with "DHCP mode"):
Eero, Google WiFi and Google OnHub
- *"Unconfigurable ISP Router"* (no way to turn off DHCP server or change router's IP) that needs at least one other device running as an Access Point:
AT&T Uverse (NVG510), Technicolor (TC8715, TC8717), Huawei (B310, B683)
- Compatible only in CUJO Bridge mode while connected to the bottom CUJO port:
Luma

DHCP Mode

To connect CUJO in **DHCP mode**, the router must have the ability to turn off the DHCP server. Most routers are compatible with this configuration.

To set DHCP mode manually, use the app and you will see instructions for manual DHCP setup:

- 1) Log in to your router
- 2) Navigate to the page (it's usually under Advanced settings and called Local Area Network (LAN)) where you can change the router's IP address and DHCP settings
- 3) Disable the DHCP server (and change router's IP if needed)
- 5) Save settings
- 6) Reboot the CUJO device (unplug the power cord from CUJO and plug it back in)

Some routers (like "[Xfinity](#)" or "[Apple AirPort](#)") does not have the ability to disable the DHCP server, in this case there is a special configuration that helps CUJO override your router's DHCP server. You will need to:

- 1) Log in to your router
- 2) If the CUJO app asks, change your router's IP. Save settings. Your router will reboot. Then try to log in to your router using the new IP.
- 3) Add the CUJO device to the static IP reservation list and remember the current CUJO IP (write it down for the next step).
- 4) Set the new range of the DHCP server on your router to this reserved CUJO IP. Save settings. Your router may reboot again.

After these steps complete successfully, CUJO will override the DHCP server on your network.

Network Setup Examples

Your ISP usually provides either the *modem* and *router* as separate devices or as a combo all in one box. If you have one device that combines the modem and router, we will simply call it *router*.

Also, if you can connect more than one device to your ISP's box or if it has WiFi capabilities, that usually means that you have *router*, not a modem.

So, you may have one of these device configurations provided by your ISP:

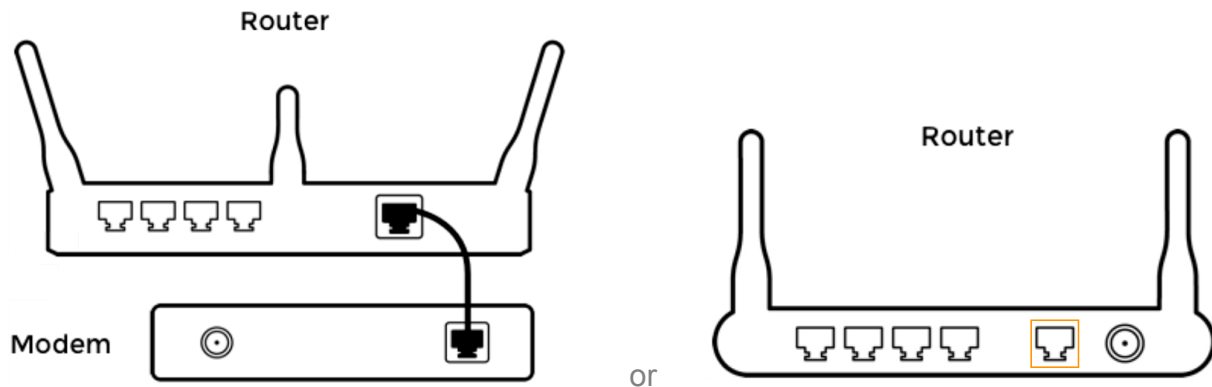

Definitions for advanced users:

Modem - a device that does not have NAT and DHCP server capabilities

Router - a device that does have and runs the NAT and DHCP server

- ⚠️ CUJO can only be connected to your ISP's router, not your ISP's modem.
- ⚠️ If you have the setup with an ISP modem and "Bridge mode only" router, then you need to get an additional device that provides NAT and DHCP.
- ⚠️ If you have one of the "Unconfigurable ISP Routers", then you need to get an additional device that will server as your Access Point.

The preferred CUJO mode options according to your current network setup:

- 1) **DHCP mode:** Router → *devices*
- 2) **Bridge mode:** Router → “*Bridge mode only*” router → *devices*
- 3) **Bridge mode:** Router → Access Point | Switch → *devices*
- 4) **DHCP mode:** Router → *device* + “*Bridge mode only*” router | Access Point | Switch → *devices*
- 5) **Incompatible:** “*Bridge mode only*” router → *devices*
- 6) **Incompatible:** “*Unconfigurable ISP Router*” → *devices*
- 7) **Bridge mode:** “*Unconfigurable ISP Router*” → “*Bridge mode only*” router → *devices*
- 8) **Bridge mode:** “*Unconfigurable ISP Router*” → Access Point | Switch → *devices*

* In the above modes where we say *devices*, you may have any device connected to the network or you can have another Switch or Access Point that will extend your network

Option 1: Router → *devices*



All your devices connected to your router will be protected by CUJO.

Option 2: Router → “Bridge mode only” router → devices

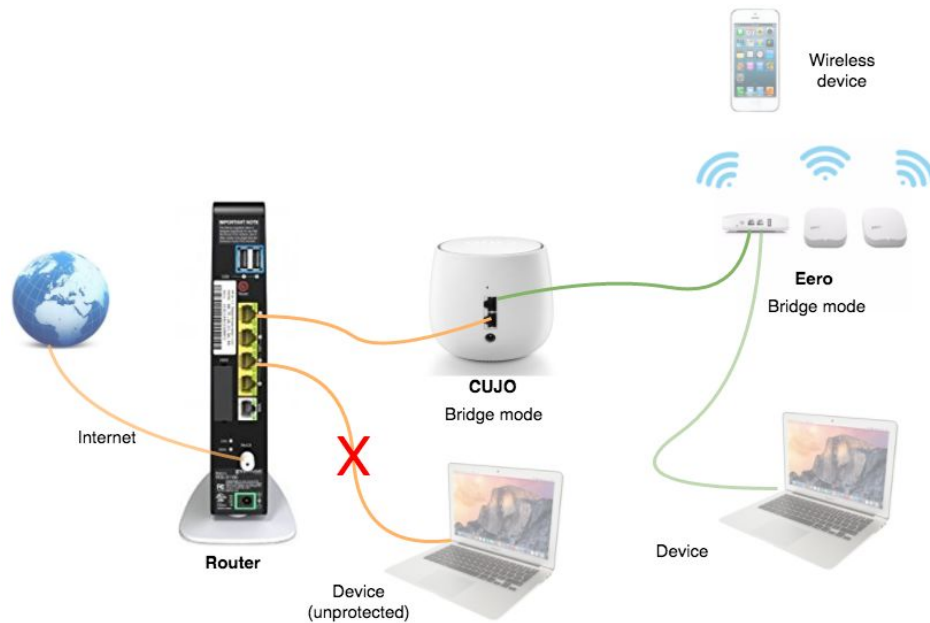

You need to set the mode of the “Bridge mode only” router to Bridge mode

If you have devices connected to your router, then they will be unprotected by CUJO. CUJO will only protect devices connected to the “Bridge mode only” router. If you want to protect all your network devices, then you need to run CUJO in DHCP mode, see Option 4

Option 3: Router → Access Point | Switch → *devices*

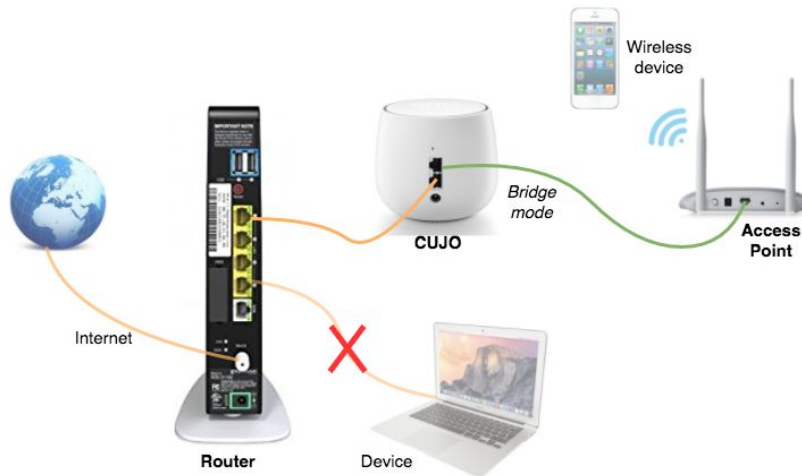

If you have devices connected to your router, then they will be unprotected by CUJO. CUJO will only protect the devices connected to the Access Point. If you want to protect all your network devices, then you need to run CUJO in DHCP mode, see Option 4

Option 4: Router → *device* + “Bridge mode only” router | Access Point | Switch → *devices*



In this setup, CUJO will protect all your network devices, whether they are connected directly to router or through the access point (switch or router in bridge mode)

Option 5: “Bridge mode only” router → devices

Incompatible



To connect CUJO in this setup, you need to replace your modem with a modem + router combo box or connect another router to get network setup Option 1.

Option 6: “Unconfigurable ISP Router” → devices

Incompatible



To connect CUJO in this setup, you need to get an additional device running as an Access Point to get network setup Option 7 or Option 8.

Option 7: “Unconfigurable ISP Router” → “Bridge mode only” router → devices



You need to set the mode of the “Bridge mode only” router to Bridge mode.

If you have devices connected to your router, then they will be unprotected by CUJO. CUJO will only protect the devices connected to the “Bridge mode only” router.

Option 8: “Unconfigurable ISP Router” → Access Point | Switch → devices

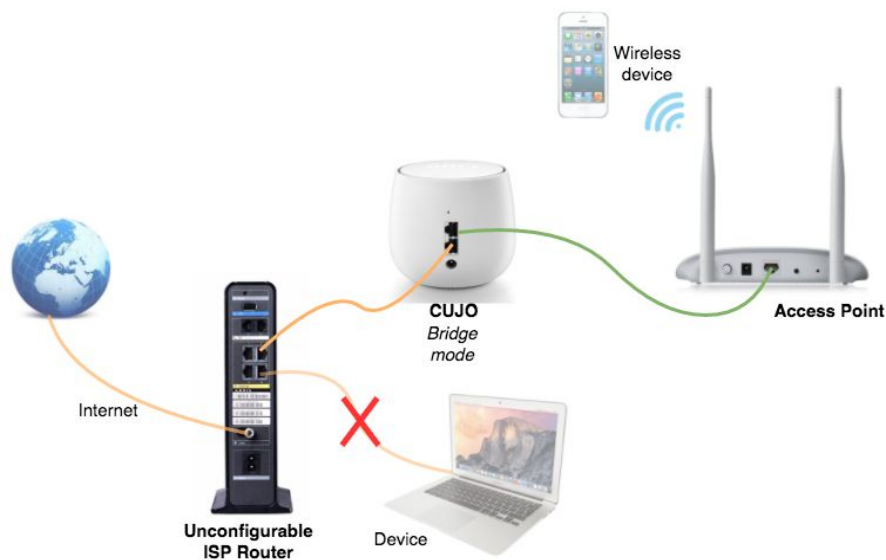

If you have devices connected to your router, then they will be unprotected by CUJO. CUJO will only protect the devices connected to the Access Point.

Advanced network example

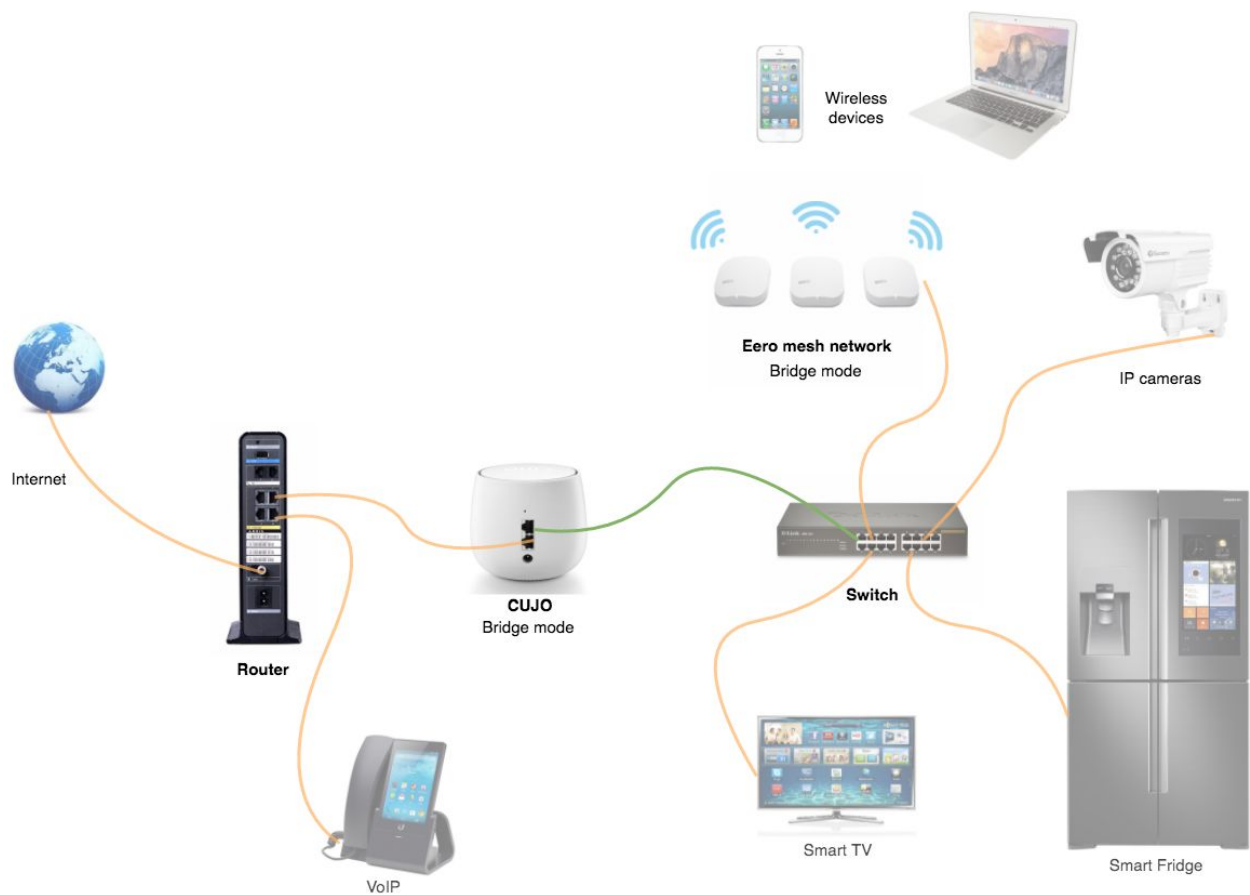

Comments:

- The main router will serve as NAT and the default DHCP server on the network
- Other routers on the network need to run in Access Point, Bridge, or Switch modes
- We recommend VoIP and other real time streaming sensitive devices be left outside CUJO's scope since CUJO does not have QoS implementation

CUJO Specification

Certifications	FCC, ETL (similar to UL), WEEE, CE (pending RoHS/REACH), Safety Cert
Dimensions (W x H x D)	4.875" x 4.875" x 5.75" (124mm x 124mm x 146mm)
Weight	0.831 lbs (without packaging) (377g)
Features	Internet security for all devices Parental Controls (coming soon...) VPN (coming soon...) Bridge or DHCP server mode Customizable DHCP settings (Subnet, IP range, Lease time, Static IP, DNS) Live Video Customer Service support
Security Features	Safe Browsing (IP/DNS) Command & Control blocking Unauthorized access blocking Antivirus and Antimalware Behavior Analysis Local+Cloud security layers DoS attack protection Protection of all devices on the network (like PC, Phone, TV, Camera and etc.)
Management Features	CUJO App: iOS/Android for Phones Minimal requirements: iOS 8.4.1, screen 640x960 Android 4.1.1, screen 540x960
Ambient Temperature	32°F - 104°F (0°C - 40°C)
Processor	Dual Core 1GHz
Flash Memory	4GB Flash
SDRAM Memory	1GB DDR SRAM
Acceleration	Cryptographic Hardware Acceleration
Ports	2 x 1Gbps Ethernet Ports
External Power Supply	Input: 100-240V ~ 0.3A 50-60Hz Output: 5V DC 2.0A Max Plugs: US/CA, EU, AU/NZ, UK, Other countries

Legal Notice

Terms of Service

Welcome to the CUJO LLC (“CUJO”) Terms of Service (the “Terms”). Please read these Terms and our [Privacy Policy](http://www.getcujo.com/privacy) (www.getcujo.com/privacy) carefully because they govern your use of our website located at www.getcujo.com (the “Site”) and the services we offer through our products and our mobile device application (“App”). To make these Terms easier to read, the Site, our services and App are collectively called the “Services.”

Agreement to Terms

By using our Services, you agree to be bound by these Terms. If you don’t agree to be bound by these Terms, do not use the Services. If you are accessing and using the Services on behalf of a company (such as your employer) or other legal entity, you represent and warrant that you have the authority to bind that company or other legal entity and each of its affiliates to these Terms. In that case, “you” and “your” will refer to that company or other legal entity and its affiliates.

Privacy Policy

Please refer to our Privacy Policy (www.getcujo.com/privacy) for information on how we collect, use and disclose information from our users. You acknowledge and agree that your use of the Services is subject to our Privacy Policy.

Changes to Terms or Services

We may modify the Terms at any time, in our sole discretion. If we do so, we’ll let you know either by posting the modified Terms on the Site or through other communications. It’s important that you review the Terms whenever we modify them because if you continue to use the Services after we have posted modified Terms on the Site, you are indicating to us that you agree to be bound by the modified Terms. If you don’t agree to be bound by the modified Terms, then you may not use the Services anymore. Because our Services are evolving over time we may change or discontinue all or any part of the Services, at any time and without notice, at our sole discretion.

ARBITRATION NOTICE: UNLESS YOU OPT OUT OF ARBITRATION WITHIN 30 DAYS OF THE DATE YOU FIRST AGREE TO THESE TERMS BY FOLLOWING THE OPT-OUT PROCEDURE SPECIFIED IN THE “ARBITRATION” SECTION BELOW, AND EXCEPT FOR CERTAIN TYPES OF DISPUTES DESCRIBED IN THE “ARBITRATION” SECTION BELOW, YOU AGREE THAT DISPUTES BETWEEN YOU AND CUJO WILL BE RESOLVED BY BINDING, INDIVIDUAL ARBITRATION AND YOU ARE WAIVING YOUR RIGHT TO A TRIAL BY JURY OR TO PARTICIPATE AS A PLAINTIFF OR CLASS MEMBER IN ANY PURPORTED CLASS ACTION OR REPRESENTATIVE PROCEEDING.

Who May Use the Services

Eligibility

You may use the Services only if you are 18 years or older and capable of forming a binding contract with CUJO and are not barred from using the Services under applicable law.

Registration and Your Information

If you want to use certain features of the Services you’ll have to create an account (“Account”). You can do this via the CUJO app.

It’s important that you provide us with accurate, complete and up-to-date information for your Account and you agree to update such information, as needed, to keep it accurate, complete and up-to-date. If you don’t, we might have to suspend or terminate your Account. You agree that you won’t disclose your Account password to anyone and you’ll notify us immediately of any unauthorized use of your Account. You’re responsible for all activities that occur under your Account, whether or not you know about them.

Feedback

We welcome feedback, comments and suggestions for improvements to the Services (“Feedback”). You can submit Feedback by emailing us at hi@getcujo.com. You grant to us a non-exclusive, worldwide, perpetual, irrevocable, fully-paid, royalty-free, sublicensable and transferable license under any and all intellectual property rights that you own or control to use, copy, modify, create derivative works based upon and otherwise exploit the Feedback for any purpose.

Content and Content Rights

For purposes of these Terms “Content” means text, graphics, images, music, software, audio, video, works of authorship of any kind, and information or other materials that are posted, generated, provided or otherwise made available through the Services.

Content Ownership, Responsibility and Removal

CUJO and its licensors exclusively own all right, title and interest in and to the Services and Content, including all associated intellectual property rights. You acknowledge that the Services and Content are protected by copyright, trademark, and other laws of the United States and foreign countries. You agree not to remove, alter or obscure any copyright, trademark, service mark or other proprietary rights notices incorporated in or accompanying the Services or Content.

Rights in Content Granted by CUJO

Subject to your compliance with these Terms, CUJO grants you a limited, non-exclusive, non-transferable, non-sublicensable license to download, view, copy, display and print the Content solely in connection with your permitted use of the Services and solely for your personal and non-commercial purposes.

Rights and Terms for Software and Apps

Rights in Software

Subject to your compliance with these Terms, with respect to any software installed or embedded in any CUJO products (“Software”), CUJO grants you a limited non-exclusive, non-transferable, non-sublicensable license to use the Software on the CUJO product solely for your own personal non-commercial purposes. You may not: (i) copy, modify, translate or create derivative works based on the Software; (ii) distribute, transfer, publish, disclose, sublicense, lease, lend, sell or rent the Software to any third party; (iii) reverse engineer, decompile, reverse decompile or disassemble the Software, or otherwise attempt to derive the source code; (iv) make the functionality of the Software available to third parties or multiple users through any means, or (v) benchmark or conduct any performance or comparison tests on the Software. CUJO reserves all rights in and to the Software not expressly granted to you under these Terms.

Rights in App Granted by CUJO

Subject to your compliance with these Terms, CUJO grants you a limited non-exclusive, non-transferable, non-sublicensable license to download and install a copy of the App on a mobile device or computer that you own or control and to run such copy of the App solely for your own personal non-commercial purposes. You may not copy the App, except for making a reasonable number of copies for backup or archival purposes. Except as expressly permitted in these Terms, you may not: (i) copy, modify, translate or create derivative works based on the App; (ii) distribute, transfer, publish, disclose, sublicense, lease, lend, sell or rent the App to any third party; (iii) reverse engineer, decompile, reverse decompile or disassemble the App, or otherwise attempt to derive the source code; (iv) make the functionality of the App available to third parties or multiple users through any means, or (v) benchmark or conduct any performance or comparison tests on the App. CUJO reserves all rights in and to the App not expressly granted to you under these Terms.

Rights in Subscription Service

Subject to your payment for the applicable term of the subscription (e.g. 12 months), CUJO will provide you with its cloud connectivity that fights internet of things hacking and protects from identity theft, financial fraud, device destruction and other home security problems by automatically blocking hacks, based on machine learning, behavioral intelligence and cloud data (the “Subscription Service”) for your own personal non-commercial purposes. The term of the Subscription Service will continue on the date of purchase of the applicable CUJO product (or the date you purchase a renewed subscription) and

continue for the applicable term purchased. CUJO will have the right to terminate the Subscription Service prior to expiration of the applicable term by providing you notice, provided that if you purchased a term by paying in advance (e.g. a \$0 Subscription or 12-month Subscription), then upon any termination CUJO will refund to you a pro-rata portion of the payment you made for the term of the Subscription Services (the \$0 Subscription will be deemed a 30 months term for refund purpose). By way of example, if you paid \$60 for a 12-month term of the Subscription Services, and CUJO terminates the term after 6 months, then CUJO would refund \$30.

General Prohibitions and CUJO's Enforcement Rights

You agree not to do any of the following:

- Use, display, mirror or frame the Services or any individual element within the Services, CUJO's name, any CUJO trademark, logo or other proprietary information, or the layout and design of any page or form contained on a page, without CUJO's express written consent;
- Access, tamper with, or use non-public areas of the Services, CUJO's computer systems, or the technical delivery systems of CUJO's providers;
- Attempt to probe, scan or test the vulnerability of any CUJO system or network or breach any security or authentication measures;
- Avoid, bypass, remove, deactivate, impair, descramble or otherwise circumvent any technological measure implemented by CUJO or any of CUJO's providers or any other third party (including another user) to protect the Services or Content;
- Attempt to access or search the Services or Content or download Content from the Services through the use of any engine, software, tool, agent, device or mechanism (including spiders, robots, crawlers, data mining tools or the like) other than the software and/or search agents provided by CUJO or other generally available third-party web browsers;
- Send any unsolicited or unauthorized advertising, promotional materials, email, junk mail, spam, chain letters or other form of solicitation;
- Use any meta tags or other hidden text or metadata utilizing a CUJO trademark, logo URL or product name without CUJO's express written consent;
- Use the Services or Content, or any portion thereof, for any commercial purpose or for the benefit of any third party or in any manner not permitted by these Terms;
- Forge any TCP/IP packet header or any part of the header information in any email or newsgroup posting, or in any way use the Services or Content to send altered, deceptive or false source-identifying information;
- Attempt to decipher, decompile, disassemble or reverse engineer any of the software used to provide the Services or Content;
- Interfere with, or attempt to interfere with, the access of any user, host or network, including, without limitation, sending a virus, overloading, flooding, spamming, or mail-bombing the Services;
- Collect or store any personally identifiable information from the Services from other users of the Services without their express permission;
- Impersonate or misrepresent your affiliation with any person or entity;
- Violate any applicable law or regulation; or
- Encourage or enable any other individual to do any of the foregoing.

Although we're not obligated to monitor access to or use of the Services or Content or to review or edit any Content, we have the right to do so for the purpose of operating the Services, to ensure compliance with these Terms, and to comply with applicable law or other legal requirements. We reserve the right, but are not obligated, to remove or disable access to any Content, at any time and without notice, including, but not limited to, if we, at our sole discretion, consider any Content to be objectionable or in violation of these Terms. We have the right to investigate violations of these Terms or conduct that affects the Services. We may also consult and cooperate with law enforcement authorities to prosecute users who violate the law.

Links to Third Party Websites or Resources

The Services and App may contain links to third-party websites or resources. We provide these links only as a convenience and are not responsible for the content, products or services on or available from those websites or resources or links displayed on such websites. You acknowledge sole responsibility for and assume all risk arising from, your use of any third-party websites or resources.

Termination

We may terminate your access to and use of the Services, at our sole discretion, at any time and without notice to you. You may cancel your Account at any time by sending an email to us at hi@getcujo.com. Upon any termination, discontinuation or cancellation of Services or your Account, all provisions of these Terms which by their nature should survive will survive, including, without limitation, ownership provisions, warranty disclaimers, limitations of liability, and dispute resolution provisions.

Warranty Disclaimers

CUJO provides a limited warranty on its hardware device as follows: For a period of one (1) year following the purchase date of the device, CUJO will repair or replace any device that was defective as of the date of purchase. CUJO does not provide any warranty for any data that may be stored on the device or CUJO's servers and CUJO does not provide any warranty regarding such data. EXCEPT FOR THE FOREGOING WARRANTY, THE SERVICES AND CONTENT ARE PROVIDED "AS IS," WITHOUT WARRANTY OF ANY KIND. WITHOUT LIMITING THE FOREGOING, WE EXPLICITLY DISCLAIM ANY WARRANTIES OF MERCHANTABILITY, FITNESS FOR A PARTICULAR PURPOSE, QUIET ENJOYMENT OR NON-INFRINGEMENT, AND ANY WARRANTIES ARISING OUT OF COURSE OF DEALING OR USAGE OF TRADE. We make no warranty that the Services will meet your requirements or be available on an uninterrupted, secure, or error-free basis. We make no warranty regarding the quality, accuracy, timeliness, truthfulness, completeness or reliability of any Content.

Indemnity

You will indemnify and hold harmless CUJO and its officers, directors, employee and agents, from and against any claims, disputes, demands, liabilities, damages, losses, and costs and expenses, including, without limitation, reasonable legal and accounting fees arising out of or in any way connected with, (ii) your use of these Services, or (iii) your breach of these Terms.

Limitation of Liability

NEITHER CUJO NOR ANY OTHER PARTY INVOLVED IN CREATING, PRODUCING, OR DELIVERING THE SERVICES OR CONTENT WILL BE LIABLE FOR ANY INCIDENTAL, SPECIAL, EXEMPLARY OR CONSEQUENTIAL DAMAGES, INCLUDING LOST PROFITS, LOSS OF DATA OR GOODWILL, SERVICE INTERRUPTION, COMPUTER DAMAGE OR NETWORK INTERRUPTION OR IMPACT ON OTHER DEVICES OR SYSTEM FAILURE OR THE COST OF SUBSTITUTE SERVICES ARISING OUT OF OR IN CONNECTION WITH THESE TERMS OR FROM THE USE OF OR INABILITY TO USE THE SERVICES OR CONTENT, WHETHER BASED ON WARRANTY, CONTRACT, TORT (INCLUDING NEGLIGENCE), PRODUCT LIABILITY OR ANY OTHER LEGAL THEORY, AND WHETHER OR NOT CUJO HAS BEEN INFORMED OF THE POSSIBILITY OF SUCH DAMAGE, EVEN IF A LIMITED REMEDY SET FORTH HEREIN IS FOUND TO HAVE FAILED OF ITS ESSENTIAL PURPOSE. SOME JURISDICTIONS DO NOT ALLOW THE EXCLUSION OR LIMITATION OF LIABILITY FOR CONSEQUENTIAL OR INCIDENTAL DAMAGES, SO THE ABOVE LIMITATION MAY NOT APPLY TO YOU.

IN NO EVENT WILL CUJO'S TOTAL LIABILITY ARISING OUT OF OR IN CONNECTION WITH THESE TERMS OR FROM THE USE OF OR INABILITY TO USE THE SERVICES OR CONTENT EXCEED THE



AMOUNTS YOU HAVE PAID TO CUJO FOR USE OF THE SERVICES OR CONTENT IN THE SIX (6) MONTHS PRIOR TO THE APPLICABLE EVENT.

THE EXCLUSIONS AND LIMITATIONS OF DAMAGES SET FORTH ABOVE ARE FUNDAMENTAL ELEMENTS OF THE BASIS OF THE BARGAIN BETWEEN CUJO AND YOU.

Dispute Resolution

Governing Law

These Terms and any action related thereto will be governed by the laws of the State of California without regard to its conflict of laws provisions.

Agreement to Arbitrate

You and CUJO agree that any dispute, claim or controversy arising out of or relating to these Terms or the breach, termination, enforcement, interpretation or validity thereof or the use of the Services or Content (collectively, "Disputes") will be settled by binding arbitration, except that each party retains the right: (i) to bring an individual action in small claims court and (ii) to seek injunctive or other equitable relief in a court of competent jurisdiction to prevent the actual or threatened infringement, misappropriation or violation of a party's copyrights, trademarks, trade secrets, patents or other intellectual property rights (the action described in the foregoing clause (ii), an "IP Protection Action"). Without limiting the preceding sentence, you will also have the right to litigate any other Dispute if you provide CUJO with written notice of your desire to do so by email or regular mail at 2150 Park Place Suite 100, El Segundo, CA 90245, (1-844-GET- CUJO) within thirty (30) days following the date you first agree to these Terms (such notice, an "Arbitration Opt-out Notice"). If you don't provide CUJO with an Arbitration Opt-out Notice within the thirty (30) day period, you will be deemed to have knowingly and intentionally waived your right to litigate any Dispute except as expressly set forth in clauses (i) and (ii) above. The exclusive jurisdiction and venue of any IP Protection Action or, if you timely provide CUJO with an Arbitration Opt-out Notice, will be the state and federal courts located in the Northern District of California and each of the parties hereto waives any objection to jurisdiction and venue in such courts. Unless you timely provide CUJO with an Arbitration Opt- out Notice, you acknowledge and agree that you and CUJO are each waiving the right to a trial by jury or to participate as a plaintiff or class member in any purported class action or representative proceeding. Further, unless both you and CUJO otherwise agree in writing, the arbitrator may not consolidate more than one person's claims, and may not otherwise preside over any form of any class or representative proceeding. If this specific paragraph is held unenforceable, then the entirety of this "Dispute Resolution" section will be deemed void. Except as provided in the preceding sentence, this "Dispute Resolution" section will survive any termination of these Terms.

Arbitration Rules

The arbitration will be administered by the American Arbitration Association ("AAA") in accordance with the Commercial Arbitration Rules and the Supplementary Procedures for Consumer Related Disputes (the "AAA Rules") then in effect, except as modified by this "Dispute Resolution" section. (The AAA Rules are available at www.adr.org/arb_med or by calling the AAA at 1-800-778-7879.) The Federal Arbitration Act will govern the interpretation and enforcement of this Section.

Arbitration Process

A party who desires to initiate arbitration must provide the other party with a written Demand for Arbitration as specified in the AAA Rules. The arbitrator will be either a retired judge or an attorney licensed to practice law and will be selected by the parties from the AAA's roster of arbitrators. If the parties are unable to agree upon an arbitrator within seven (7) days of delivery of the Demand for Arbitration, then the AAA will appoint the arbitrator in accordance with the AAA Rules.

Arbitration Location and Procedure

Unless you and CUJO otherwise agree, the arbitration will be conducted in the county where you reside. If your claim does not exceed \$10,000, then the arbitration will be conducted solely on the basis of the documents that you and CUJO submit to the arbitrator, unless you request a hearing or the arbitrator determines that a hearing is necessary. If your claim exceeds \$10,000, your right to a hearing will be determined by the AAA Rules. Subject to the AAA Rules, the arbitrator will have the discretion to direct a reasonable exchange of information by the parties, consistent with the expedited nature of the arbitration.

Arbitrator's Decision

The arbitrator will render an award within the time frame specified in the AAA Rules. The arbitrator's decision will include the essential findings and conclusions upon which the arbitrator based the award. Judgment on the arbitration award may be entered in any court having jurisdiction thereof. The arbitrator's award of damages must be consistent with the terms of the "Limitation of Liability" section above as to the types and amounts of damages for which a party may be held liable. The arbitrator may award declaratory or injunctive relief only in favor of the claimant and only to the extent necessary to provide relief warranted by the claimant's individual claim. If you prevail in arbitration you will be entitled to an award of attorneys' fees and expenses, to the extent provided under applicable law. CUJO will not seek, and hereby waives all rights it may have under applicable law to recover, attorneys' fees and expenses if it prevails in arbitration.

Fees

Your responsibility to pay any AAA filing, administrative and arbitrator fees will be solely as set forth in the AAA Rules. However, if your claim for damages does not exceed \$75,000, CUJO will pay all such fees unless the arbitrator finds that either the substance of your claim or the relief sought in your Demand for Arbitration was frivolous or was brought for an improper purpose (as measured by the standards set forth in Federal Rule of Civil Procedure 11(b)).

Changes

Notwithstanding the provisions of the "Modification" section above, if CUJO changes this "Dispute Resolution" section after the date you first accepted these Terms (or accepted any subsequent changes to these Terms), you may reject any such change by sending us written notice (including by email to hi@getcujo.com) within 30 days of the date such change became effective, as indicated in the "Last Updated" date above or in the date of CUJO's email to you notifying you of such change. By rejecting any change, you are agreeing that you will arbitrate any Dispute between you and CUJO in accordance with the provisions of this "Dispute Resolution" section as of the date you first accepted these Terms (or accepted any subsequent changes to these Terms).

General Terms

These Terms constitute the entire and exclusive understanding and agreement between CUJO and you regarding the Services and Content, and these Terms supersede and replace any and all prior oral or written understandings or agreements between CUJO and you regarding the Services and Content. If any provision of these Terms is held invalid or unenforceable (either by an arbitrator appointed pursuant to the terms of the "Arbitration" section above or by court of competent jurisdiction, but only if you timely opt out of arbitration by sending us an Arbitration Opt-out Notice in accordance with the terms set forth above), that provision will be enforced to the maximum extent permissible and the other provisions of these Terms will remain in full force and effect. You may not assign or transfer these Terms, by operation of law or otherwise, without CUJO's prior written consent. Any attempt by you to assign or transfer these Terms, without such consent, will be null. CUJO may freely assign or transfer these Terms without restriction. Subject to the foregoing, these Terms will bind and inure to the benefit of the parties, their successors and permitted assigns.

Any notices or other communications provided by CUJO under these Terms, including those regarding modifications to these Terms, will be given: (i) via email; or (ii) by posting to the Services. For notices made by e-mail, the date of receipt will be deemed the date on which such notice is transmitted.

CUJO's failure to enforce any right or provision of these Terms will not be considered a waiver of such right or provision. The waiver of any such right or provision will be effective only if in writing and signed by a duly authorized representative of CUJO. Except as expressly set forth in these Terms, the exercise by either party of any of its remedies under these Terms will be without prejudice to its other remedies under these Terms or otherwise.

Contact Information

If you have any questions about these Terms or the Services, please contact CUJO at hi@getcujo.com, 1-844-GET-CUJO, 2150 Park Place Suite 100, El Segundo, CA 90245





COMPLIANCE STATEMENT

We,

CUJO LLC
2150 Park Place Suite#100
El Segundo,
CA 90245
USA

Declare under our sole responsibility that the product:

Brand = CUJO
Model No = A0001
Product Description = Home Internet Security Device

Comply:

- FCC Compliance:
According to 47CFR, Part 15 for: Class B Personal Computers and
Peripherals:

We: CUJO LLC
Located at: 2150 Park Place, Suit 100, El Segundo, CA 90245
Telephone: 1-844-GET-CUJO

Declare under sole responsibility that the product identified herein, complies with 47CFR Part 15 of the FCC rules as a Class B digital device. Each product marketed is identical to the representative unit tested and found to be compliant with the standards. Records maintained continue to reflect the equipment being produced can be expected to be within the variation accepted, due to quantity production and testing on a statistical basis as required by 47CFR § 2.909. Operation is subject to the following two conditions: (1) this device may not cause harmful interference, and (2) this device must

accept any interference received, including interference that may cause undesired operation.

Trade Name: CUJO
Type of Product: Home Internet Security Device
Model: A0001

Note: This equipment has been tested and found to comply with the limits for a Class B digital device, pursuant to Part 15 of the FCC Rules. These limits are designed to provide reasonable protection against harmful interference in a residential installation. This equipment generates, uses and can radiate radio frequency energy and, if not installed and used in accordance with the instructions, may cause harmful interference to radio communications. However, there is no guarantee that interference will not occur in a particular installation. If this equipment does cause harmful interference to radio or television reception, which can be determined by turning the equipment off and on, the user is encouraged to try to correct the interference by one or more of the following measures:

- Reorient or relocate the receiving antenna.
- Increase the separation between the equipment and receiver.
- Connect the equipment into an output on a circuit different from that to which the receiver is connected.
- Consult the dealer or an experienced radio/TV technician for help.

- IC Compliance:

Compliance Label: *CAN ICES-3 (B)/NMB-3(B)*

English: This Class B digital apparatus complies with Canadian ICES-003.

French: Cet appareil numérique de la classe B est conforme à la norme NMB-003 du Canada.

- ETL Compliance:



Intertek
5004947

Conforms to UL STD 60950-1
Certified to CSA STD C22.2 No. 60950-1

- CE:

The EU Directives covered by this Declaration:
Electromagnetic Compatibility Directive, 2014/30/EU EMC Council
Directive

Restriction of Hazardous Substances (RoHS) Directive 2011/65/EU
Waste Electrical and Electronic Equipment Directive (WEEE),
2012/19/EU

With the essential requirements and other relevant requirements
based on the following standards and other normative documents:

- IEC 60950-1:2005(Second Edition) + Am 1:2009 +
Am2:2013
- UL 60950-1 Issued: 2007/03/27 Ed: 2 Rev: 2014/10/14
Information Technology Equipment
- Safety Part 1: General Requirements;
- CSA C22.2#60950-1 Issued: 2007/03/27 Ed: 2 (R2012)
Information Technology Equipment
- Safety Part 1: General Requirements; Amd. 1: 2011, Amd. 2:
2014.
- CENELEC EN 55032: 2015 Immunity

- CENELEC EN 61000-6-3: 2007+ A1:2011/AC:2012
- AS/NZS CISPR 22:2009 +A1:2010
- FCC Part 15 CFR Title 47: 2016
- ICES-003: 2016 (Canada)
- VCCI V-3 / 2014.04
- 2014/30/EU EMC Directive
- CENELEC EN 55024: 2010 Immunity
- CENELEC EN 61000-6-1: 2007 Immunity
- IEC 61000-4-2: 2008
- IEC 61000-4-3: 2006 +A1:2007 +A2:2010
- IEC 61000-4-4: 2012
- IEC 61000-4-5: 2005
- IEC 61000-4-6: 2013
- IEC 61000-4-11: 2004

- Proposition 65, the Safe Drinking Water and Toxic Enforcement Act of 1986,
“WARNING: This product contains a chemical known to the State of California to cause cancer, birth defects or other reproductive harm.”

For more information go to: <https://www.p65warnings.ca.gov>

This conformity is understood as being effective if the products for which it is given is installed and used according to the instructions provided in the user’s guide.

California, January 31 , 2017

Sameer Nayar

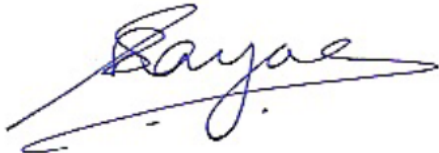
A handwritten signature in blue ink, appearing to read 'Sameer Nayar', with a long horizontal stroke extending to the right.

Chief Operating Officer
CUJO LLC