

3 D / P R I N T E R

ENTINA

3D
PRINTER

EN

USER'S MANUAL

ENTINA
3D
PRINTER

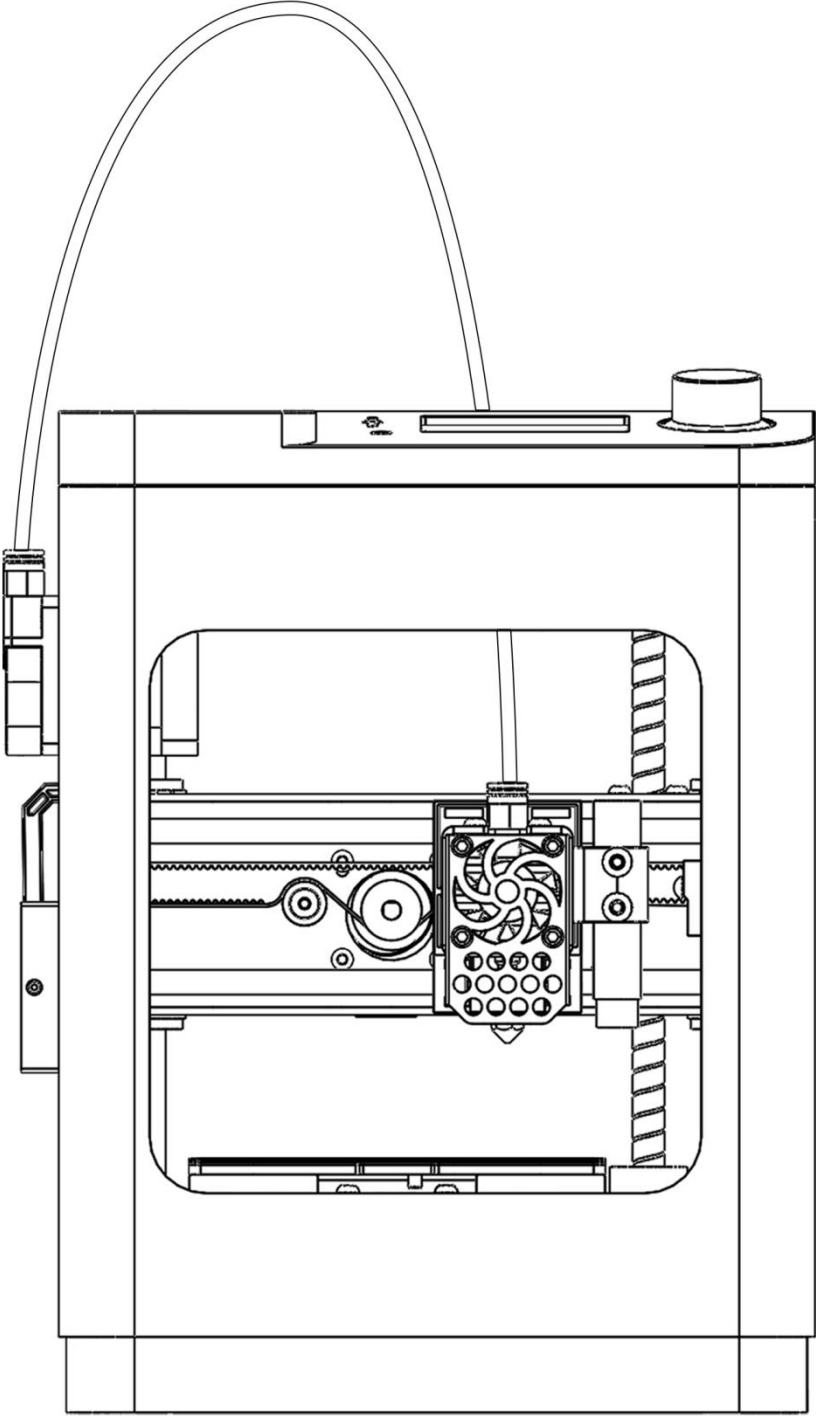

CONTENTS

1. NOTES	1
1.1. Safety Warnings	1
1.2. Filament	2
1.3. Environmental Requirements	2
2. INTRODUCTION	3
2.1. Specification	3
2.2. Product Overview	4
2.3. Motherboard and Adapter Board	4
2.4. Internal Structure	5
3. SYSTEM MENU	6
3.1. Basic Menu Control	7
3.2. Info Screen	7
3.3. Prepare Menu	8
3.4. Control Menu	13
3.5. Print from TF card	19
4. COMMON MENU OPERATIONS	23
4.1. Print from TF Card	23
4.2. Common setting during printing	23
4.3. Load Filament	25
4.4. Unload Filament	25
4.5. Power On Resume Print	25
5. WIIBUILDER SLICING SOFTWARE	26
5.1. Installation	26
5.2. Interface Introduction	27
5.3. Add Model	29
5.4. Adjust The Model	30

5.5. Basic Parameter Settings	31
5.6. Send Files by The Network	32
5.7. Send Files by TF Card	34
5.8. Send Files by USB	35
5.9. Advanced Parameter Settings	36
6. CURA	45
6.1. Installation	45
6.2. Interface Introduction	50
6.3. Add Model	51
6.4. Adjust The Model	51
6.5. Slice	52
6.6. Send files by the Network	53
6.7. Send Files by TF card	54
7. PRINT BY APP	55

1. NOTES

PLEASE READ THIS MANUAL BEFORE USING THE DEVICE, PAYING EXTRA ATTENTION TO THESE SAFETY WARNINGS AND GUIDELINES. PLEASE KEEP THIS MANUAL IN A SAFE PLACE FOR FUTURE REFERENCE.

1.1. Safety Warnings

- Do not touch the nozzle or stepper motors, when the 3D printer is printing or just finished the printing job, the nozzle temperature is up to 230°C.
- Do not expose this device to water or moisture of any kind. Do not place drinks or other containers with moisture on or near the device. If moisture does get in or on the device, immediately unplug it from the power outlet and allow it to fully dry before reapplying power.
- Do not touch the device, the power cord, or any other connected cables with wet hands.
- Prior to operation, check the unit and power cord for physical damage. Do not use if physical damage has occurred.
- Before plugging the unit into a power outlet, ensure that the outlet provides the same type and level of power required by the device.
- Unplug this device from the power source when not in use.
- Take care to prevent damage to the power cord. Do not allow it to become crimped, pinched, walked on, or become tangled with other cords. Ensure that the power cord does not present a tripping hazard.
- Never unplug the unit by pulling on the power cord. Always grasp the connector head or adapter body.
- Ensure that the 3D printer is turned off and unplugged from its power source before making repairs or performing service.

1.2. Filament

To use this 3D printer, please use the filament provided by our company. Filaments sold in the retail market have different specifications and uneven quality, which can easily clog and damage the nozzle and motor. If the 3D printer fails due to the use of third-party consumables, the warranty will not be granted.

If the filaments are not used for a long time after unpacking, please seal them and preserve them. PLA will absorb moisture when exposed to air for a long time, affecting the quality of printed products.

1.3. Environmental Requirements

This 3D printer is intended for indoor use only. The ideal ambient temperature is 15°C - 25°C. When the ambient temperature is lower than 10°C, the printing model is hard to adhere to the platform. When the ambient temperature is lower than 0°C, the device will not startup. When the ambient temperature is higher than 30°C, the print quality will decline significantly and the nozzle may be clogged.

2. INTRODUCTION

2.1. Specification

Model	TINA2S
Printing Technology	FDM
Build Volume	100 x 105 x 100mm /3.9''x 4.0''x 3.9''
Nozzle Diameter	0.4mm
Layer Thickness	0.1-0.4mm
Platform Material	Flexible Spring Steel
Leveling Technology	3 Points Auto Bed Leveling
Maximum Nozzle Temperature	245°C
Motherboard	Silent Motherboard with TMC2208
Maximum Heated Bed Temperature	60°C
Maximum Printing Speed	200mm/s
Printing Precision	±0.1mm
Product Weight	3Kg/6.6lbs
Power Supply	AC 100-240V, DC 12V5A, 60W
Filament Diameter	1.75mm
Supported Filament Type	PLA / PLA+ / TPU
Supported Filament Weight	100g-250g, with built in filament holder 1Kg, with filament rack (extra purchase)
Supported Slicing Software	Wiibuilder (Windows/MacOS) Cura-ENTINA (Windows/MacOS) OctoPrint (Pi OS/Linux)
Supported Model File Types	STL/OBJ/GCODE
Input Method	TF Card / WIFI / USB / APP
APP	PoloPrint Cloud (Android/IOS)

2.2. Product Overview

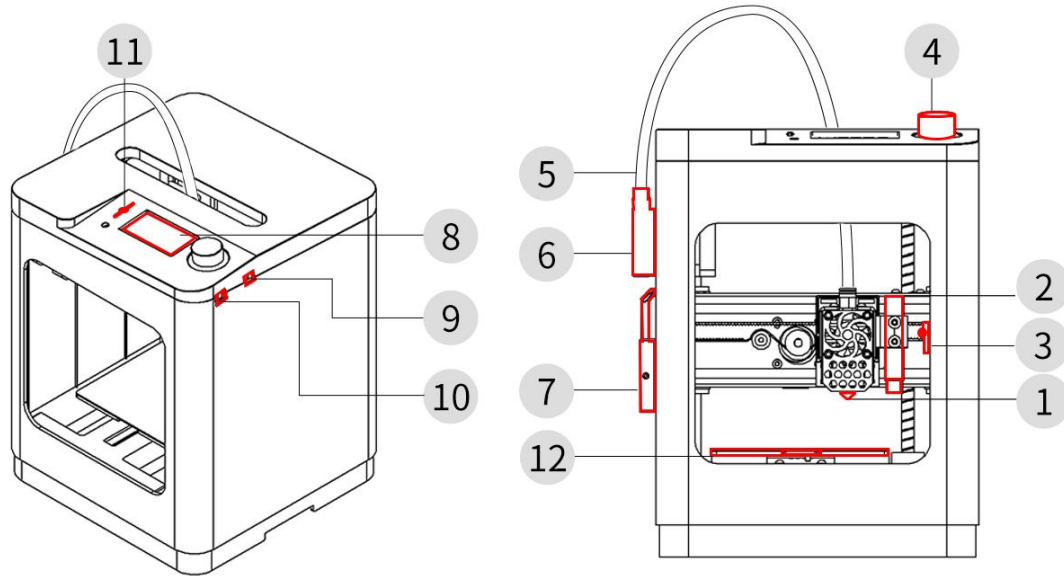

- | | | |
|---|------------------------|--------------------|
| 1. Knob | 2. Power socket | 3.USB socket |
| 4. Hotend (Heat break, Heated aluminum block, Nozzle) | 5. Heated Bed Platform | |
| 6. Extruder | 7. Proximity Sensor | 8. Filament Holder |
| 9. TF Card slot | 10. Screen | 11. Filament Tube |

2.3. Motherboard and Adapter Board

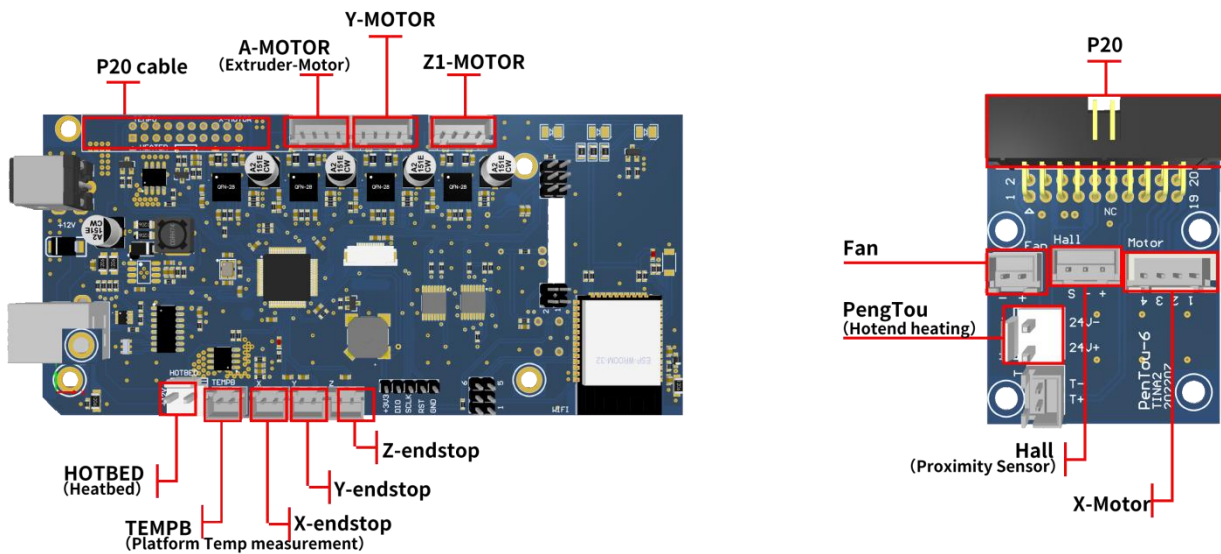

2.4. Internal Structure

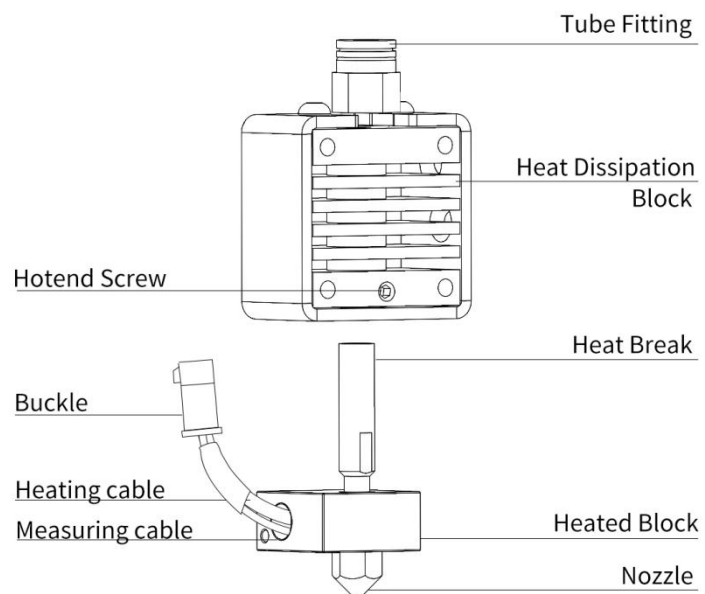
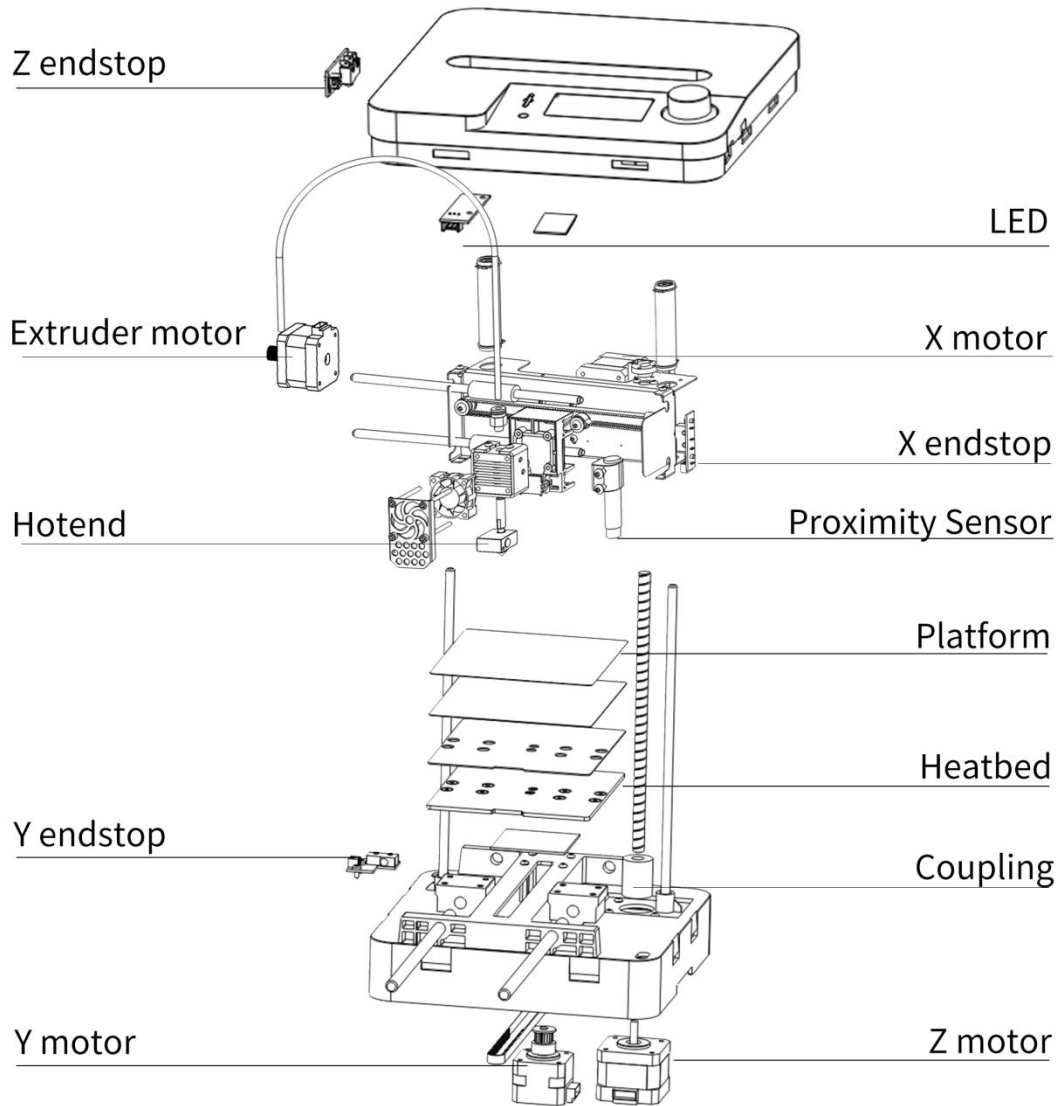

3. SYSTEM MENU

In the operation panel area on the top of the 3D printer, the left side is the TF card slot. The print data file is stored in the TF card. In the middle is an LCD screen, and on the right is a knob button. Press the knob button to open the system menu.

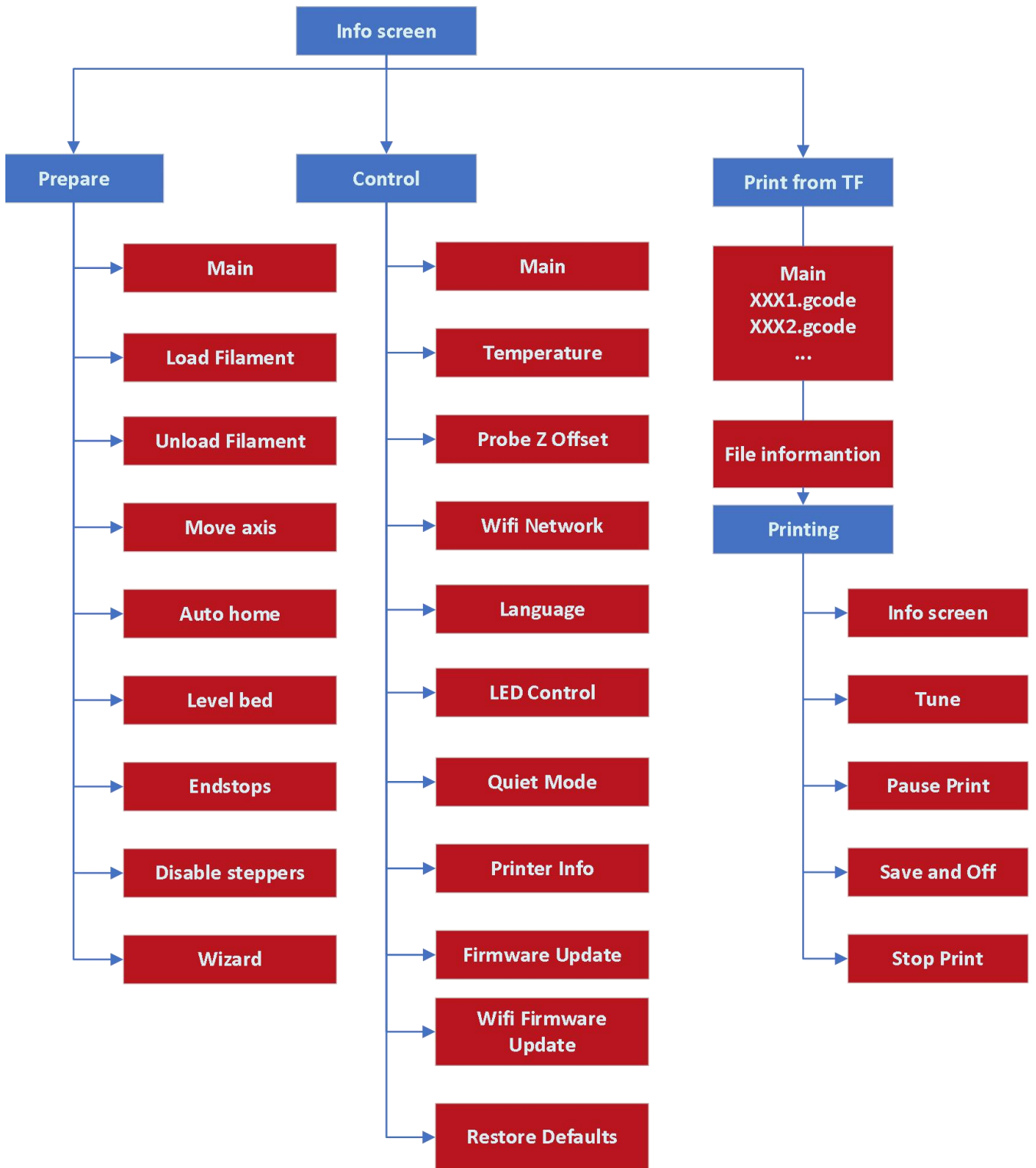

3.1. Basic Menu Control

- Turn the knob clockwise to move the highlight down on the menus or to decrease a value.
- Turn the knob counterclockwise to move the highlight up on the menus or to increase a value.
- Press the knob to enter the submenu, select the highlighted option, or accept the edited value.

3.2. Info Screen

After TINA2S starts up, the Info Screen is displayed.



Info Screen displays the status of the main components, including: Nozzle temperature (preset temperature and actual temperature), heated bed temperature (preset temperature and actual temperature), network connection status, XYZ position information, remaining printing time, and TF card status.

The bottom bar of the screen is the information bar, which displays the network status after power on. When the device is not connected to the Internet, it will display "OFF". After the device is connected to the WIFI network, it will display the IP address of the device.

Press the knob to open the main menu.

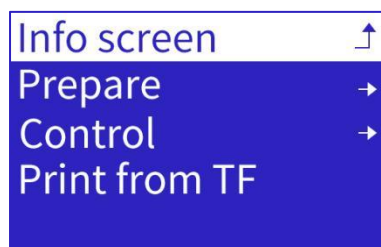

- Info Screen: Displays the info screen.
- Prepare: Displays the prepare menu.
- Control: Displays the control menu.
- Print From SD: Displays the list of TF card files.

3.3. Prepare Menu



Press the knob to open the prepare menu. This menu has two screens, turn the knob to scroll the screen.



3.3.1. Load Filament

Automatically heats the nozzle and loads the filament.

Click the button to enter the automatic loading filament interface.



The nozzle will be heated to 210°C, then the extruder will feed the filament to the nozzle. During heating or extrusion, you can press the knob button to exit the current operation.

3.3.2. Unload Filament

Automatically heats the nozzle and unloads the filament.

Click the button to enter the automatic unloading filament interface.



The nozzle will be heated to 210°C, then the extruder will retract the filament from the nozzle. During heating or extrusion, you can press the knob button to exit the current operation.

3.3.3.Move Axis

Move axis can operate each stepper motor, which can be used to debug the 3D printer or troubleshoot. Click the button to enter the sub menu.

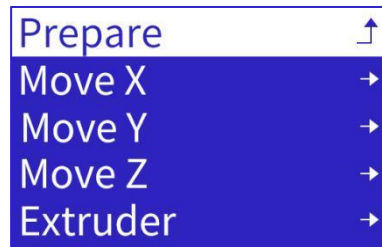

Click "Move axis", click the adjustment buttons of X, Y, Z, and control the movement of the X, Y, and Z motors respectively. The distances of X.Y.Z axis: 10mm, 1mm, 0.1mm respectively. The distance of the extruder motor: 10mm, 1mm, 0.1mm. In the debugging interface of each axis, the knob can control the bidirectional operation of the axis motor.

1.Turn the knob to control the movement of X motor.



2.Turn the knob to control the movement of Y motor.

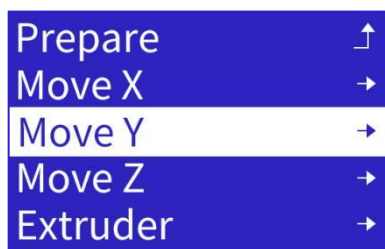

3.Turn the knob to control the movement of Z Motor.

Prepare	↕
Move X	→
Move Y	→
Move Z	→
Extruder	→

Move Z	
Move axis	↕
Move 10mm	→
Move 1mm	→
Move 0.1mm	→

Move Z: +100.0

4. Turn the knob to control the movement of extrude motor.

Prepare	↕
Move X	→
Move Y	→
Move Z	→
Extruder	→

Extruder	
Move axis	↕
Move 10mm	→
Move 1mm	→
Move 0.1mm	→

Extruder: +100.0

NOTICE:

1. THE MOVEMENT RANGE OF EACH MOTOR IS 0-100MM, PLEASE PERFORM "AUTO HOME" FIRST, AND THEN JOG TO ENSURE THAT THE 3D PRINTER OBTAINS THE CORRECT COORDINATES OF THE NOZZLE. IF "AUTO HOME" IS NOT PERFORMED, THE 3D PRINTER WILL SET THE CURRENT POSITION AS THE ORIGIN POSITION, RESULTING IN A SMALLER MOVEMENT RANGE OF THE JOG OPERATION.
2. THE MOVEMENT OF EACH MOTOR IS CONTROLLED BY THE ENDSTOP OF EACH AXIS. WHEN THE ENDSTOP IS TRIGGERED, THE MOTOR MOVEMENT STOPS IMMEDIATELY. NOTE THAT IF THE ENDSTOP IS BROKEN OR NOT WIRED PROPERLY, IT MAY GENERATE A NO-TRIGGER OR FALSE-TRIGGER SIGNAL, CAUSING THE MOTOR TO FAIL TO STOP OR MOVE.
3. THE EXTRUDER MOTOR HAS THERMAL PROTECTION FUNCTION, AND IT IS ONLY ALLOWED TO MOVE WHEN THE TEMPERATURE OF THE NOZZLE IS GREATER THAN 170°C.

3.3.4. Auto Home

Click then "Auto home", the XYZ axes will move respectively, the 3D printer nozzle and platform will automatically return to the origin, and the movement will stop after touching the each endstop.

Main	↕
Load Filament	
Unload Filament	
Move axis	→
Auto home	

This function can be used for troubleshooting. If the motor or endstop fails, this function will display a fault prompt.

3.3.5. Level Bed

Click "Level bed", the system will use the proximity sensor to do an Auto Bed Leveling operation. At the beginning of each print, system will always do the auto level bed operation, so that the nozzle and the platform maintain a proper distance during printing.



3.3.6. Endstop

Click on "Endstop" to display the status of XYZ endstops and proximity sensor. Move the nozzle or the platform to touch the endstops, and you can observe the change of the state of each endstop or the proximity sensor.

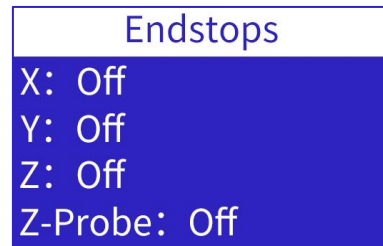

This function can be used for fault diagnosis of endstops and proximity sensor. If the endstop and proximity sensor fail, the state will not change.

3.3.7. Disable Steppers

"Disable steppers" will release the locked of the stepper motors. It is convenient to move the nozzle and platform by hand.



3.3.8.Wizard

Click " Wizard" to prompt the steps of printing TF card. This function is suitable for novice printing.

Select "Language" - "Step 1 Load Filament", heat the nozzle to the specified temperature - "Step 2 Insert TF card" - "Step 3 Print from TF card", select the file and start printing.

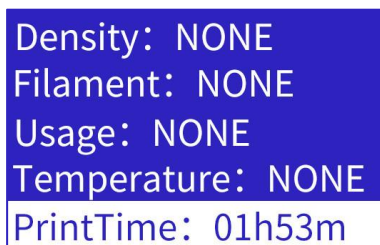
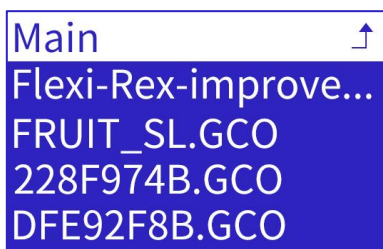

3.4. Control Menu

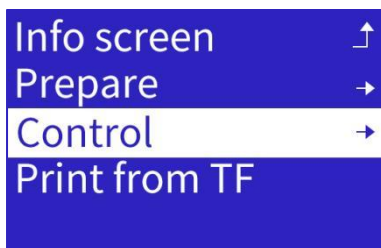

Press the knob to open the control menu. This menu has three screens, turn the knob to scroll the screen.



3.4.1. Temperature

Manually set the temperature of the nozzle or the heated bed.

Click "Temperature " to enter the page. Select the nozzle or heated bed to be heated, and click the button to confirm.



Turn the knob clockwise to reach the desired temperature, and press the knob to confirm. After the 3D printer starts to heat up, the home page will display the real time temperature of the nozzle.

If you want to perform other operations at this time, you can click the operation knob to return to the info screen, and the heating process will continue in the background. If you want to stop the 3D printer preheating, you can enter the preheating menu again, and turn the knob counterclockwise to zero.

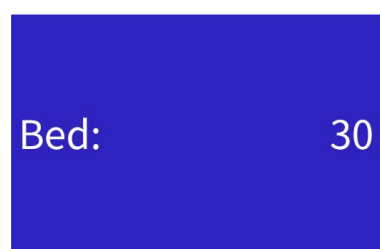

3.4.2. Prode Z Offset

After setting "Level bed", the gap between the nozzle and the platform needs to be set. If the gap is too small, the print head will scratch the platform or cause the nozzle be clogged. If the gap is too large, the printed model cannot stick to the platform well, and it is easy to cause the model to separate from the platform. It is recommended to recalibrate the Z offset after replacing the nozzle or proximity switch.

Click "Prode Z Offset" to enter the page.

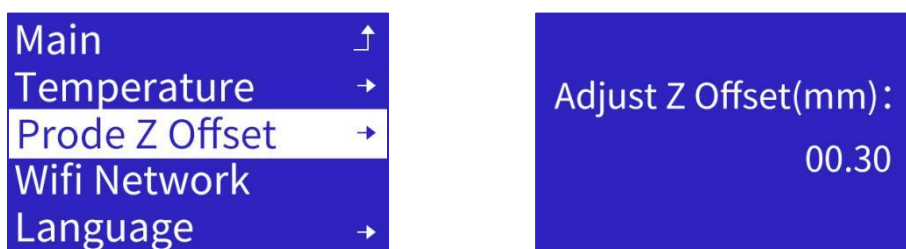

Turn the knob, the nozzle will adjust the height of the printing position up and down. Press the knob to confirm and save.

3.4.3. WIFI Network



Press the knob to open the submenu.

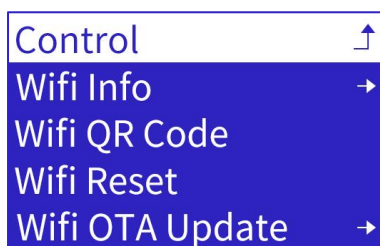

The network function of TINA2 has two connection modes, local mode, and remote mode.

Local mode: In the same local area network, Wiibuilder or Cura on the computer can connect to the 3D printer, and perform remote control or send print files. To use local mode, the 3D printer should be connected to the local WIFI network.

Remote mode: Use our APP, PoloPrint Pro, remotely control the 3D printer or download the print model. With the remote mode, you can remotely control the 3D printer from any location. To use remote mode, the 3D printer should be connected to the WIFI network and registered with the APP. Notice, a 3D printer can only be registered by one APP account.

3.4.3.1.WIFI Info

Click "WIFI Info" to open the WIFI info screen. It will show the WIFI firmware version, the serial, IP address, AP name, and the connection status of the cloud server. Only after registering in the APP, the 3D printer will connect to the cloud server.

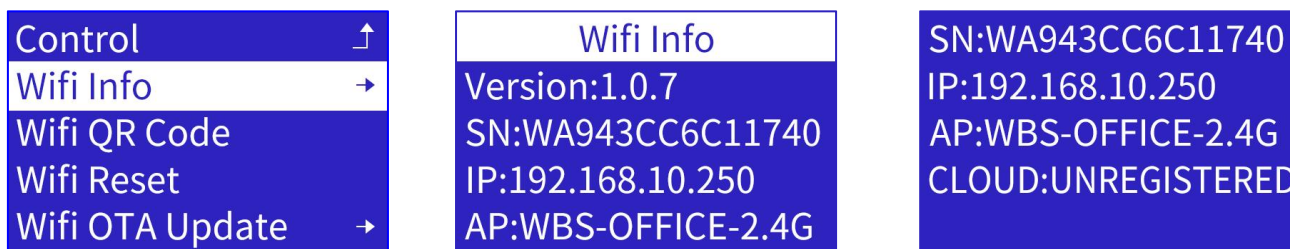

3.4.3.2.WIFI QR Code

Click "WIFI QR Code" to show the QR code generated by the device serial. Used for App scanning networking and cloud access.

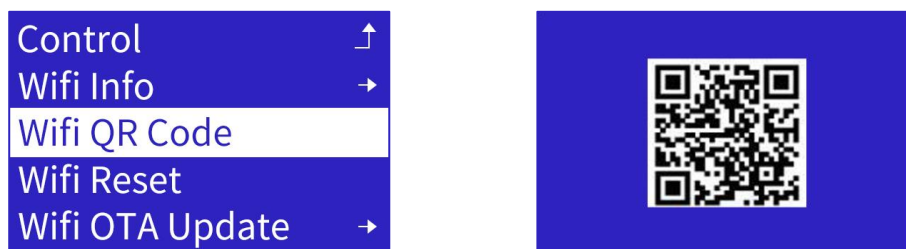

3.4.3.3.WIFI Reset

Every time TINA2 is turned on, it will automatically connect to the WIFI network that was successfully connected to the last time. If you need to connect TINA2 to a new WIFI network, you should execute the reset WIFI setting function to clear the saved WIFI network information.

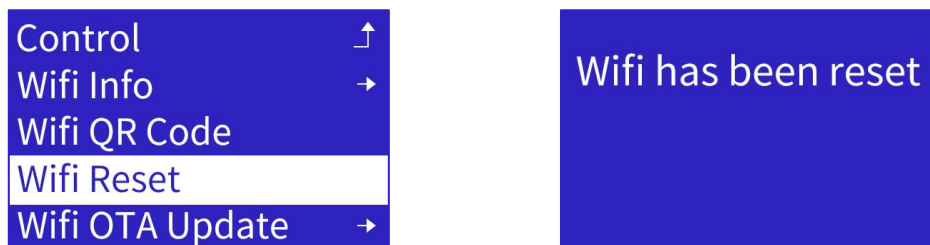

3.4.4. Language

Click "Language" to show the language list: Chinese, French, German, Italian, Japanese, Portugal, Dutch, and Turkish.

Turn the knob to choice the language you want to use, press the know to save and exit.



3.4.5. LED Control

Click "LED Control" to open the LED switch menu.

Press the knob to confirm and save.

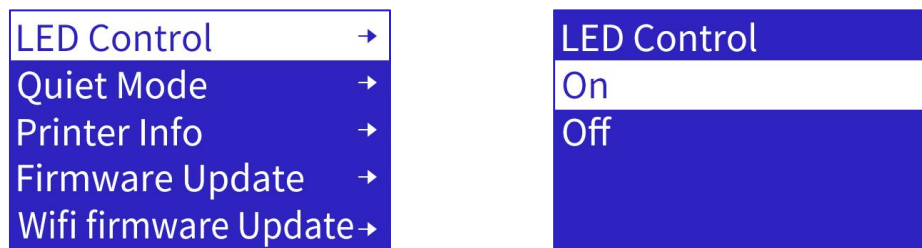

3.4.6. Quiet Mode

Click "Quiet Mode" to open the quiet mode switch menu. Quiet Mode significantly reduces the print speed to control the noise emitted.

Press the knob to confirm and save.



3.4.7. Printer Info

Click "Printer Info" to view the firmware version of the 3D printer.

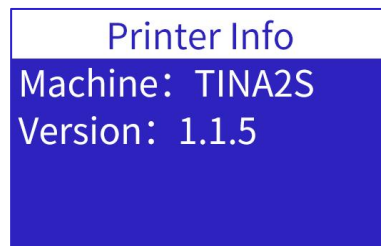

3.4.8. Firmware Update

1. Download and copy the motherboard firmware file to the root directory of the TF card. The suffix of the firmware file is wfm. If there is a compressed file, it should be decompressed first. Rename the firmware file to flash.wfm.

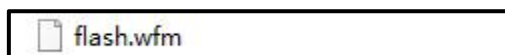

2. Insert the TF card into the 3D printer, and click "Firmware Update".
3. The 3D printer will check the version of the firmware file, and then update the motherboard firmware.

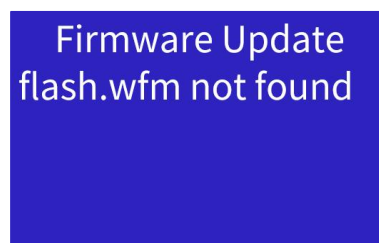

3.4.9.WIFI Firmware Update

1. Download and copy the Wifi firmware file to the root directory of the TF card. The suffix of the firmware file is efm. Rename the firmware file to wifi.efm.



2. Insert the TF card into the 3D printer, and click "WIFI firmware Update" .
3. The 3D printer will check the version of the firmware file, and then update the Wifi firmware.

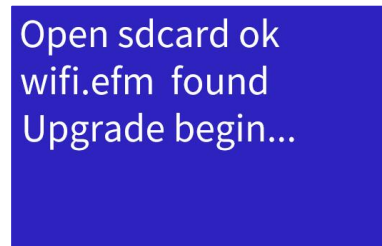

3.4.10.Restore Defaults

Click "Restore Defaults" to restore all parameters to the factory default.



3.5. Print from TF card



Show the print data files in the TF card. The suffix of the print data file is gco or gcode.

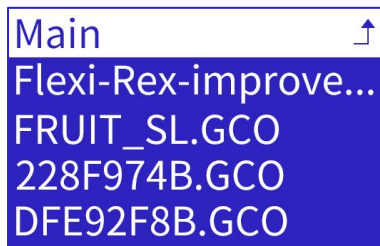

Select a file and press the knob. The next screen will show the printing information of the gcode file. Select "Print" will start printing. To prevent damage to the 3D printer, the system will check the machine model parameter in the gcode file. If the machine model parameter is not match or missing, the gcode file will not allowed to print. Please use the Wiibuilder or the customized version of Cura, select the correct model for slicing.

NOTE: THE LENGTH OF THE FILE NAME CANNOT EXCEED 20 CHARACTERS, OTHERWISE THE SYSTEM CANNOT RECOGNIZE IT OR DISPLAY GARBLED CHARACTERS.

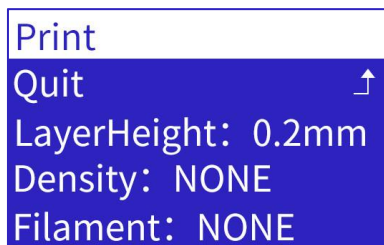

During the printing process, press the knob to open the printing setting menu.

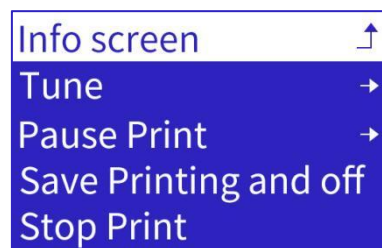

3.5.1. Tune

Select "Tune" to open the tune menu. You can adjust the print speed, nozzle temperature, heated bed temperature, extruder speed or Z offset during the printing process.

Info screen	↑
Tune	→
Pause Print	
Save Printing and Off	
Stop Print	→

Main	↑
Speed:	100
Nozzle:	200
Bed:	0
Flow:	100

Speed:	100
Nozzle:	200
Bed:	0
Flow:	100
Probe Z Offset	→

1. Select "Speed", turn the knob to reach the desired speed, and press the knob to confirm.

Main	↑
Speed:	100
Nozzle:	200
Bed:	0
Flow:	100

Speed:	100
--------	-----

2. Select "Nozzle", turn the knob to reach the desired temperature of the nozzle, and press the knob to confirm.

Main	↑
Speed:	100
Nozzle:	200
Bed:	0
Flow:	100

Nozzle:	200
---------	-----

3. Select "Bed", turn the knob to reach the desired temperature of the heated bed, and press the knob to confirm.

Main	↑
Speed:	100
Nozzle:	200
Bed:	0
Flow:	100

Bed:	0
------	---

4. Select "Probe Z Offset", turn the knob to fine tune the gap between the nozzle and the heated bed, and press the knob to confirm.

Speed:	100
Nozzle:	200
Bed:	0
Flow:	100
Probe Z Offset	→

Adjust Z Offset(mm):	-1.360
----------------------	--------

THIS FUNCTION CAN ADJUST THE HEIGHT OF THE Z AXIS IN REAL TIME TO CHANGE THE GAP BETWEEN THE NOZZLE AND THE PLATFORM DURING THE PRINTING PROCESS. AT THE BEGINNING OF PRINTING, IF IT IS OBSERVED THAT THE GAP BETWEEN THE NOZZLE AND THE PLATFORM IS TOO SMALL AND THE NOZZLE DOES NOT PRODUCE SILK, THE Z OFFSET CAN BE INCREASED BY 0.2MM.

IF IT IS OBSERVED THAT THE GAP BETWEEN THE NOZZLE AND THE PLATFORM IS TOO LARGE AND THE FILAMENT DOES NOT ADHERE WELL TO THE PLATFORM, THE Z OFFSET CAN BE GRADUALLY REDUCED.

3.5.2.Pause Print

Select "Pause Print", the 3D Printer will pause printing, and the nozzle will go to the pause position. In pause mode, you can replace the filament or resume the printing.

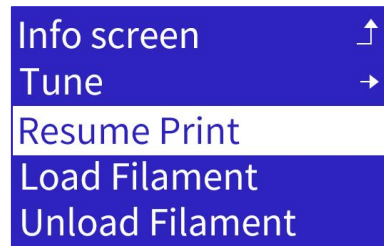

3.5.3.Save Printing and Off

Select "Save Printing and off", the 3D printer will save the current printing progress and go to the pause position. When the 3D printer stops moving, you can power off the 3D printer. The 3D printer will prompt whether to resume the printing when it is powered on next time.

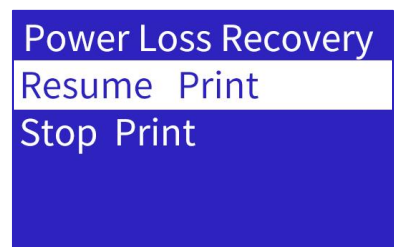
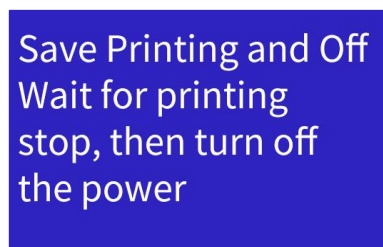

SPECIAL REMINDER:

WHEN "PAUSE PRINT" AND "SAVE PRINTING AND OFF", THE 3D PRINTER PERFORMS A HOME OPERATION. DUE TO THE MECHANICAL NATURE OF ENDSTOP, THERE WILL BE SLIGHT DEVIATIONS FOR EACH HOMING OPERATION. THEREFORE, AFTER RESUMING PRINTING, THERE WILL BE A CERTAIN SEAM OR DEVIATION IN THE POSITION WHERE THE PRINTING IS CONTINUED. THEREFORE, IT IS RECOMMENDED TO PRINT THE MODEL AT ONE TIME AS MUCH AS POSSIBLE.

3.5.4. Stop Print

Select "Stop Print", the 3D printer will cancel the current printing job and return to the Info screen.



SPECIAL REMINDER:

AFTER PRINTING HAS STOPPED, REMOVE THE MODEL FROM THE PLATFORM.

4. COMMON MENU OPERATIONS

4.1. Print from TF Card

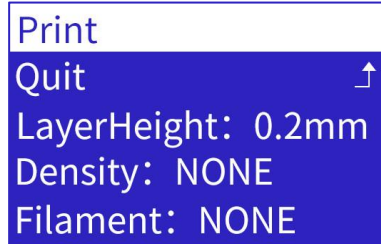

1. Open the main menu, turn the knob to the “Print From TF” and click to open the TF card file list menu.
2. Turn the knob to choose the file to print, then press the knob to start printing.

4.2. Common setting during printing

4.2.1. Pause Print

During the printing, press the knob to open the printing setting menu, choice the "Pause Print", the 3D printer will pause the printing and the nozzle will go to the pause position. Then, you can replace the filament, or resume the printing.

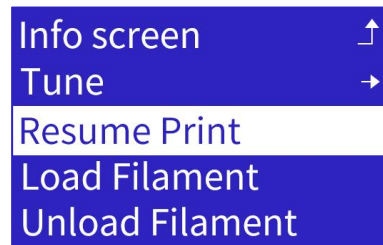
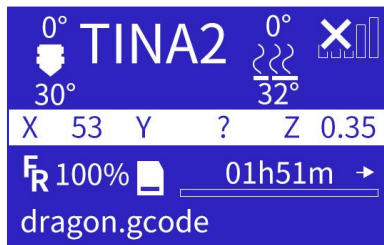

4.2.2. Modify Temperature

During the printing, press the knob to open the printing setting menu, get into the tune menu, choice the “Bed” to open then nozzle temperature adjustment function. Turn the knob to increase or decrease the temperature, press the knob to return.

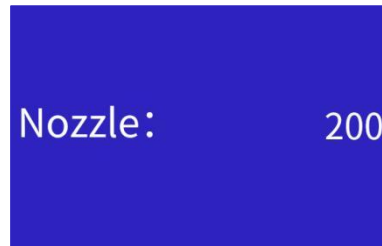
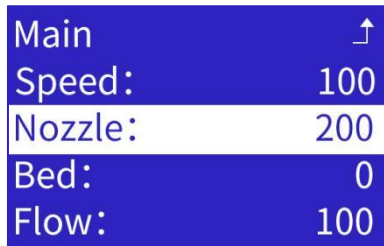

4.2.3. Modify Z Offset

I During the printing, press the knob to open the printing setting menu, get into the tune menu, choice then "Probe Z Offset" to open then Z offset adjustment function. Turn the knob to fine tune the gap between the nozzle and the platform.

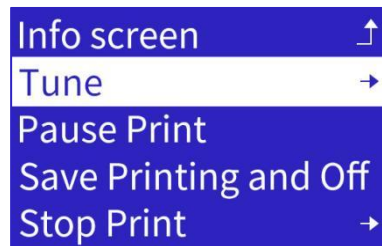
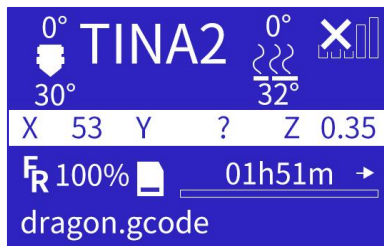

THIS FUNCTION CAN ADJUST THE HEIGHT OF THE Z AXIS IN REAL TIME TO CHANGE THE GAP BETWEEN THE NOZZLE AND THE PLATFORM DURING THE PRINTING PROCESS. AT THE BEGINNING OF PRINTING, IF IT IS OBSERVED THAT THE GAP BETWEEN THE NOZZLE AND THE PLATFORM IS TOO SMALL AND THE NOZZLE DOES NOT PRODUCE SILK, THE Z OFFSET CAN BE INCREASED BY 0.2MM. IF IT IS OBSERVED THAT THE GAP BETWEEN THE NOZZLE AND THE PLATFORM IS TOO LARGE AND THE FILAMENT DOES NOT ADHERE WELL TO THE PLATFORM, THE Z OFFSET CAN BE GRADUALLY REDUCED.

4.3. Load Filament



1. Open the main menu, then get into the prepare menu.
2. Turn the knob to the “Load Filament” and click. Once filament starts extruding from the nozzle.

4.4. Unload Filament



1. Open the main menu, the get into the prepare menu.
2. Turn the knob to the “Unload Filament” and click. The 3D printer will heat the nozzle and retract the filament.

4.5. Power On Resume Print

During printing, the 3D printer will save the current printing progress every 10s. If an unexpected power lost occurs, the 3D printer will prompt whether to resume the printing when it is powered on next time.

SPECIAL REMINDER:

WHEN PRINTING, THE 3D PRINTER WILL SAVE THE PRINTING PROGRESS EVERY 10S AND WRITE IT INTO THE ".BIN" FILE OF THE TF CARD. EACH TIME THE PROGRESS IS SAVED, THE PREVIOUS PROGRESS WILL BE DELETED. WHEN THE DEVICE IS POWERED OFF SUDDENLY AND RESTARTED, THE MACHINE WILL CHECK ONLINE WHETHER THERE IS A ".BIN" FILE IN THE MEMORY CARD. IF THERE IS, IT WILL PROMPT "CONTINUE PRINTING, STOP PRINTING"; CONTINUE PRINTING, THE DEVICE WILL READ THE SAVED PROGRESS AND STOP PRINTING, THE DEVICE WILL CLEAR THE ".BIN" FILE. HOWEVER, BECAUSE THE PROGRESS OF THE POWER OFF REPLAY IS SAVED ONCE EVERY 10S, AND THERE IS A TIME INTERVAL OF 10S, THERE IS A POSSIBILITY OF FAILURE IN THE POWER-OFF REPLAY.

5. WIIBUILDER SLICING SOFTWARE

The 3D printer includes the Wiibuilder slicing software on the included TF card. Use the included card reader to display the contents of the TF card on your PC to install the program.

Configuration requirements to run Wiibuilder:

- CPU: Pentium 1GHz
- Memory: minimum 1G
- Hard disk: more than 1G disk space
- Display resolution: minimum 640*480 pixels
- Graphics card: support 3D acceleration, support OpenGL2.0 and above
- Color: minimum 256 colors
- Operating system: Windows7 and above / MACOS8.0 and above
- Other runtime libraries: .Net Framework 4.5.2 and above

5.1. Installation

5.1.1. Installation in Windows

Perform the following steps to install the Wiibuilder slicing software.

Locate and run the Wiibuilder.exe software on the SD card to install the Wiibuilder software program. Click the Install-Next- Finishbutton to continue.

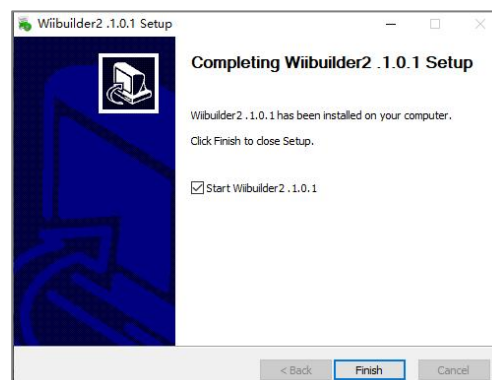
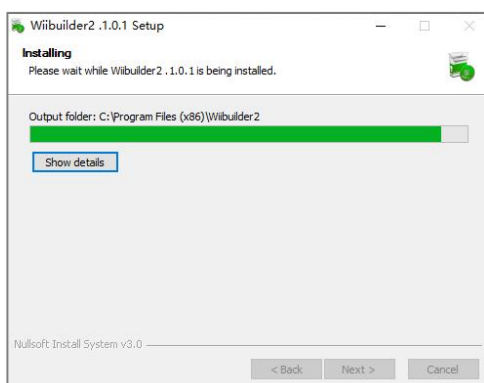
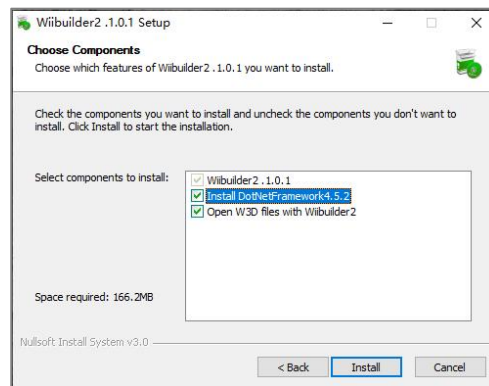
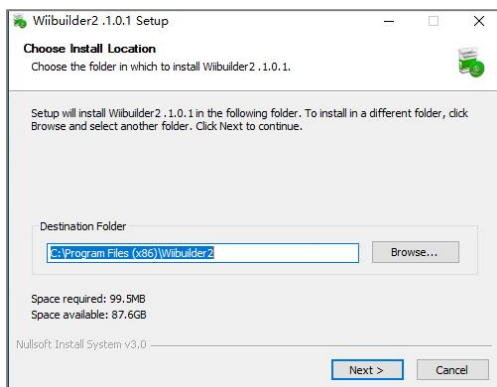

5.1.2. Installation in MacOS

Decompress the installation. Double-click to run the software installation package, drag Wiibuilder into the application, and it will be displayed.

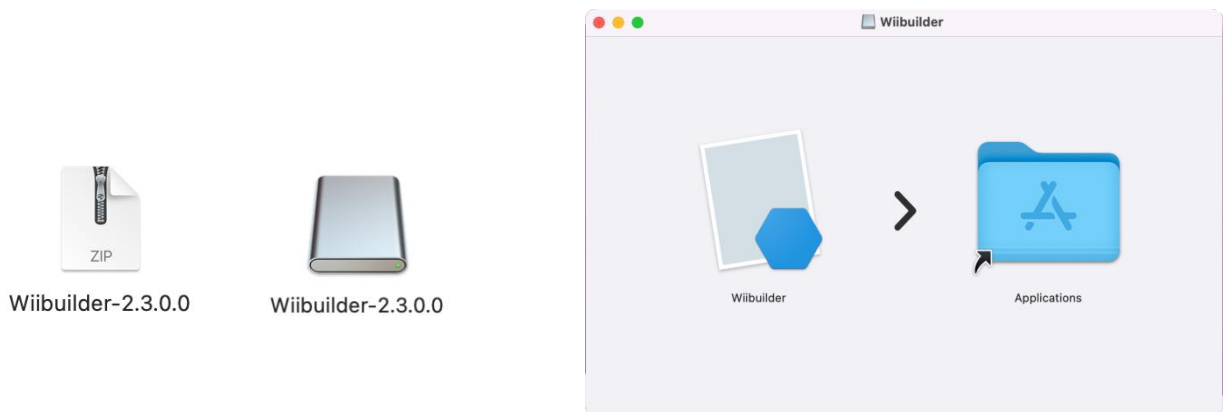

5.2. Interface Introduction

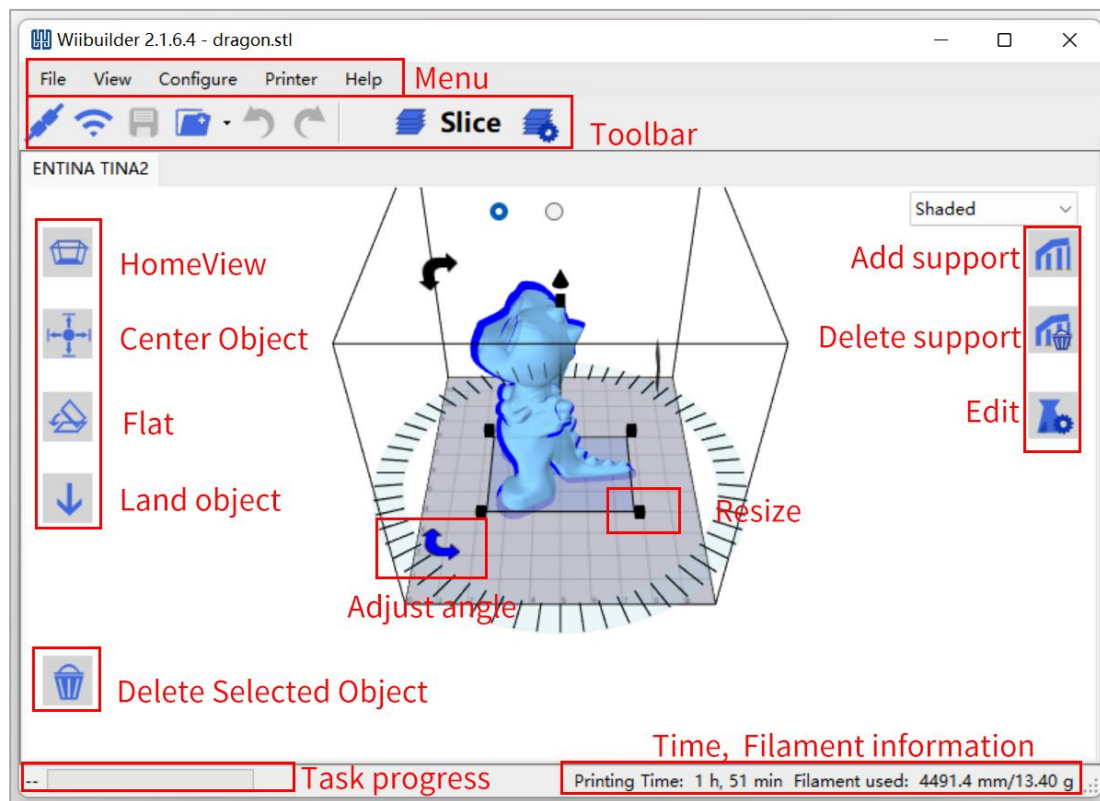

- Menu bar: Open the Wiibuilder menu.
- Toolbar: USB connection, WIFI connection, save gcode file, load model, undo, restore, execute slice, slice setting.
- Home view: Restore the default viewing angle.
- Center Object: Automatically adjust the XY coordinates of the model and place the model in the middle of the platform.

- Flat: Automatically adjust the inclination of the model, and flatten the inclined model on the platform.
- Land object: Automatically adjust the Z coordinate of the model to align the bottom of the model with the platform.
- Delete Selected Object: Delete the currently selected model.
- Add Support: Add manual support to the model.
- Delete Support: Delete the added manual support.
- Edit: Open model and Gcode editor.

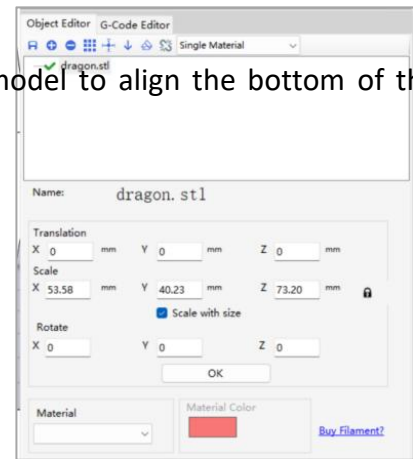

Right click on the model to open the context menu:

- Copy: Open the model copy.
- Mirror: Mirror the model according to the X, Y, Z axis directions.
- Delete: Delete the current model.
- Export: Export the current model to stl file.
- Arrange All Parts: automatically adjust the position and spacing of multiple models on the platform.
- Clear Plate: Delete all models on the platform.
- Slicing settings:

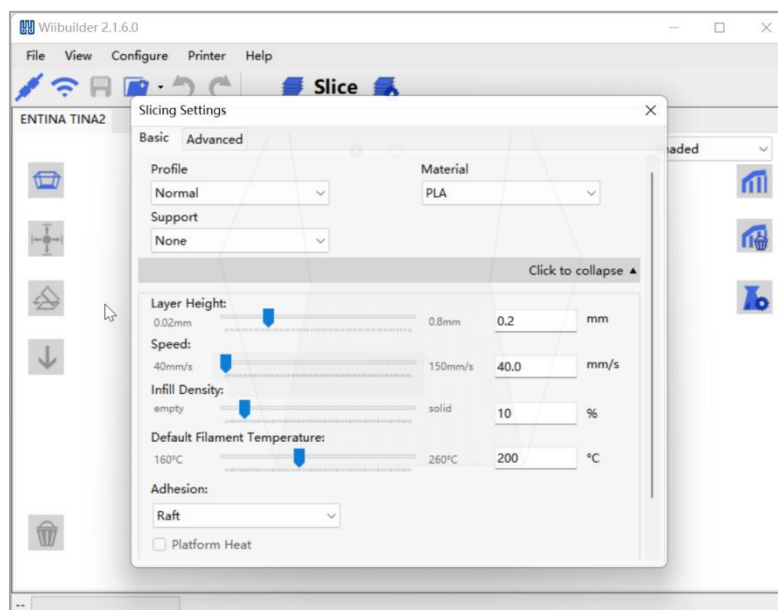
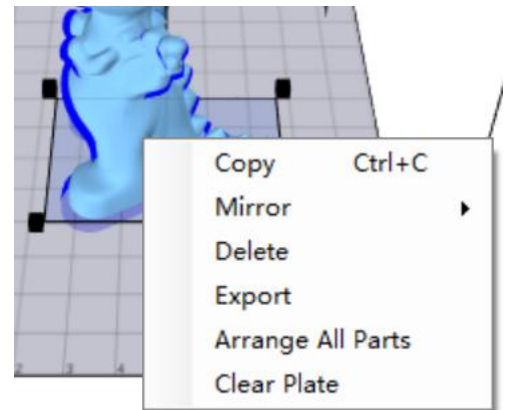

5.3. Add Model

1. Open Wiibuilder, click “File” to load the model, or just drag the model into it.

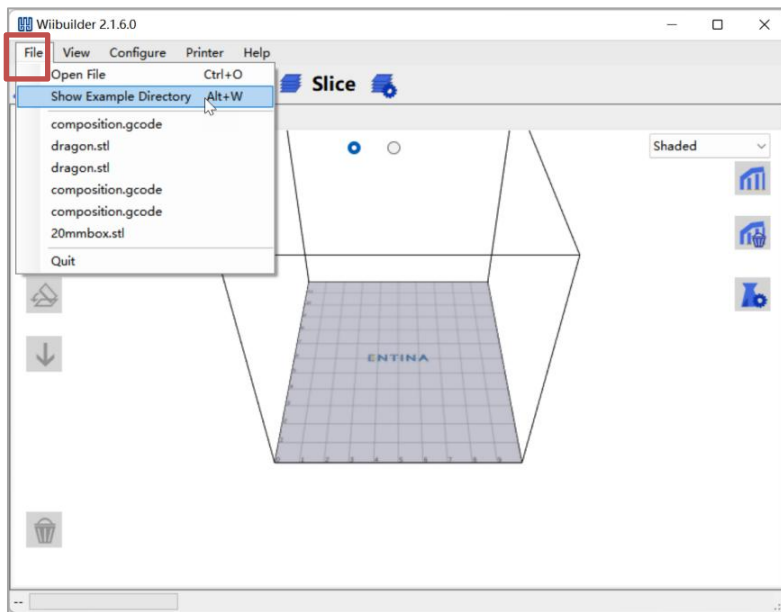

2. Five models have been stored in the “Show Example Directory”, you can use them for test printing.

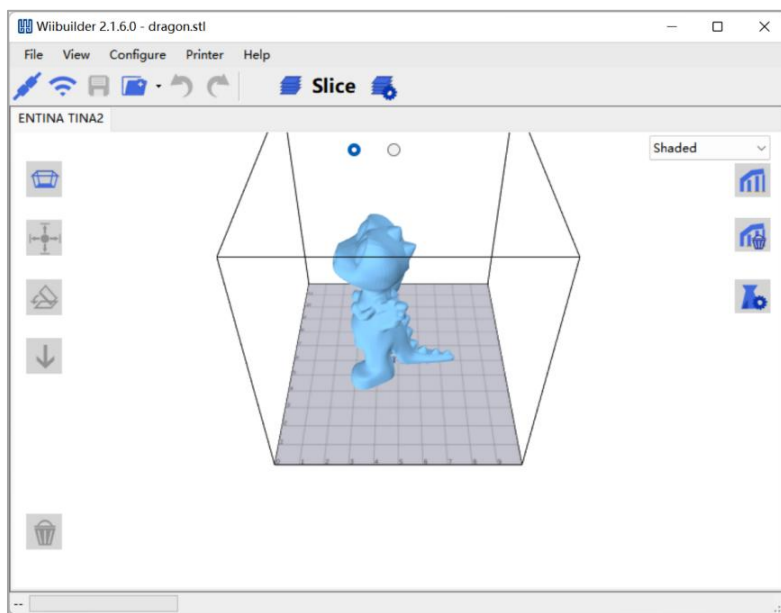

3. User can download more models through the website, such as: <https://www.thingiverse.com>

5.4. Adjust The Model

1. Click the model to adjust the size, angle, and position.

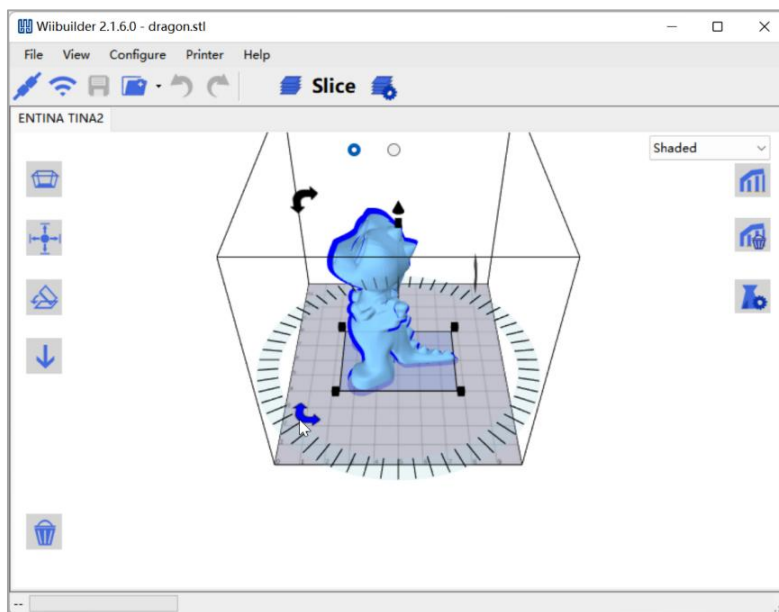

2. The model needs to be centered and correctly placed on the platform. Click "Center Object", "Flat", and "Land object".

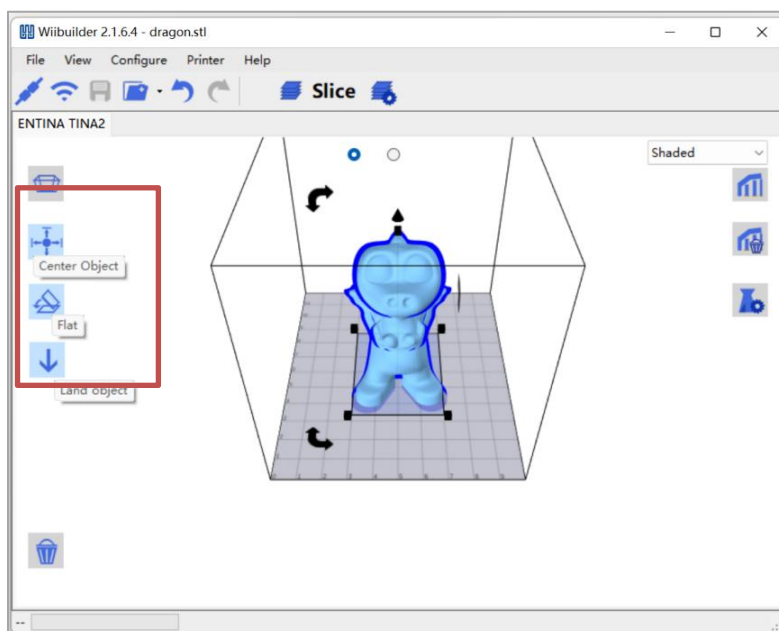

5.5. Basic Parameter Settings

Novice users can directly use the default parameters without adjustment.

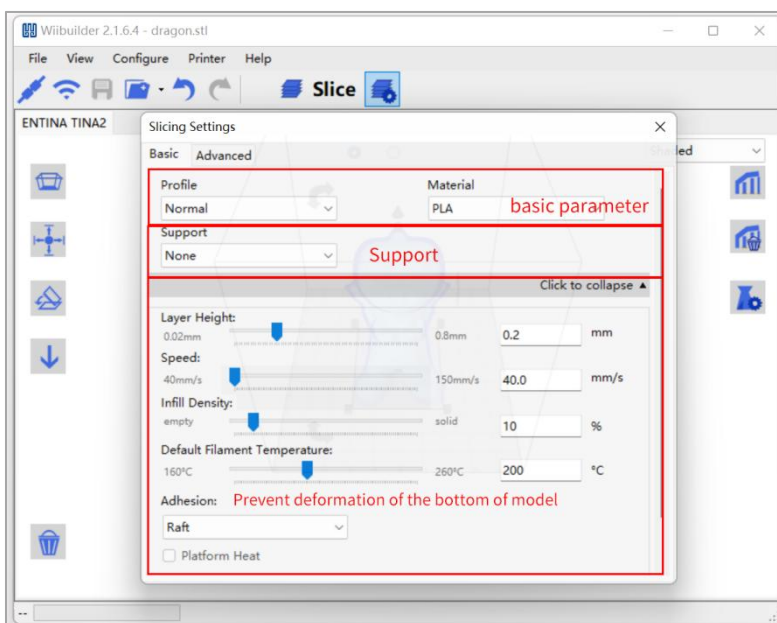

After setting the parameters, click "Slice" to convert the file.

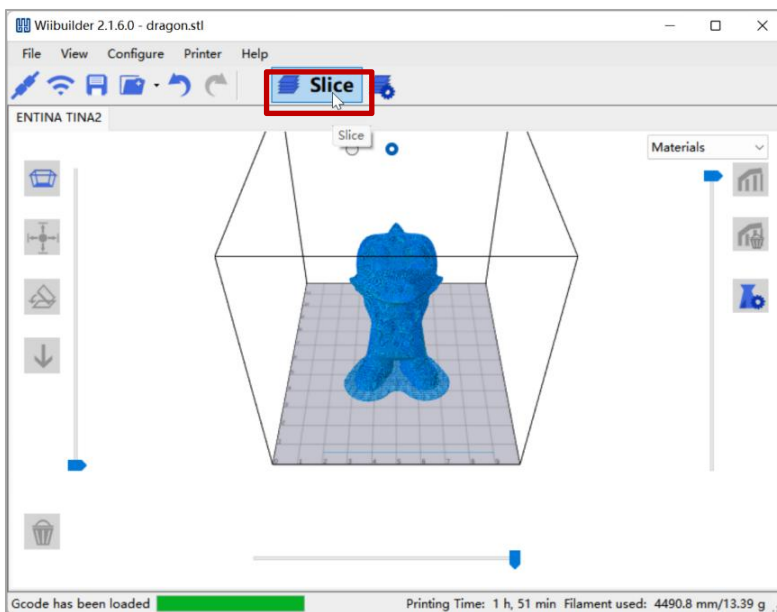

5.6. Send Files by The Network

NOTE: THE 3D PRINTER HAS BEEN CONNECTED TO THE NETWORK, AND THE IP ADDRESS IS DISPLAYED. FOR OPERATIONS, PLEASE REFER TO: "PRINT BY APP".



1. The computer should connect to the same local network with the 3D printer.

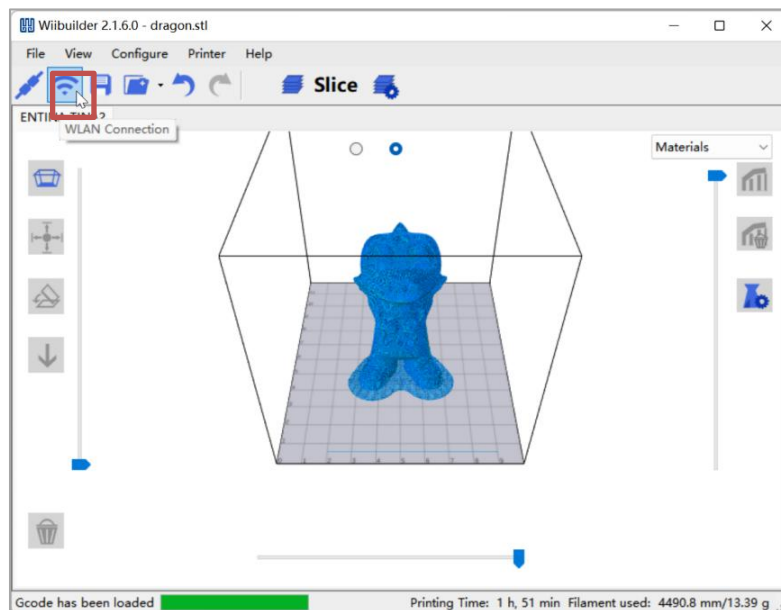

2. Click "WLAN Connection", the software will automatically search for the 3D printers in the local network and show them in the below list. If no 3D printer be found, you can also try to manually enter the IP address of the 3D printer to connect.

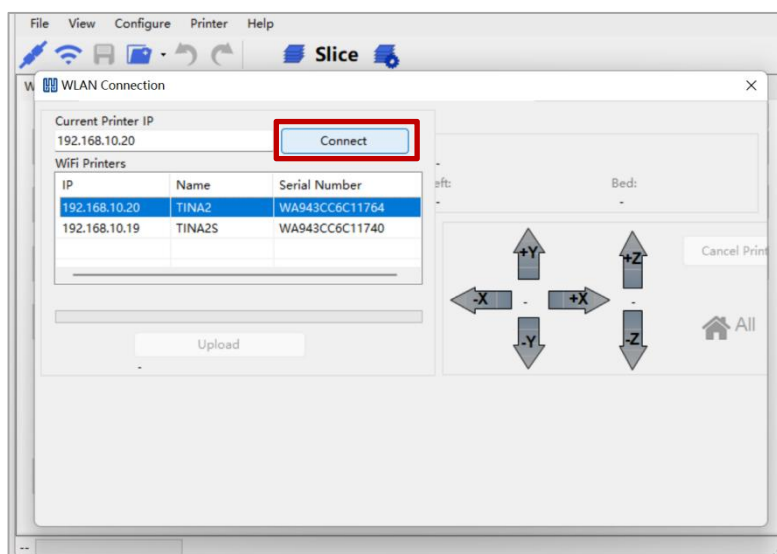

NOTE: IF YOU STILL CANNOT CONNECT TO THE 3D PRINTER, PLEASE CHECK WHETHER THE FIREWALL OF THE COMPUTER PROHIBITS THE SOFTWARE FROM NETWORKING, AND WHETHER THE COMPUTER AND THE 3D PRINTER ARE IN THE SAME LOCAL AREA NETWORK.

3. Send the sliced model to the 3D printer, and the 3D printer starts printing after receiving it.

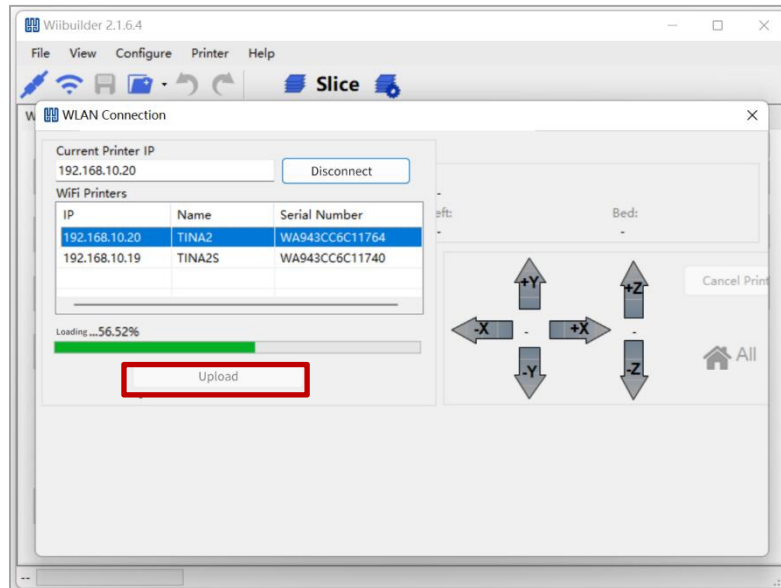

5.7. Send Files by TF Card

Save the sliced model to the TF card, insert the TF card into the 3D printer and print.

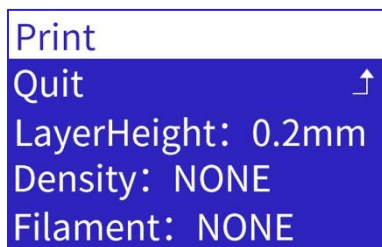
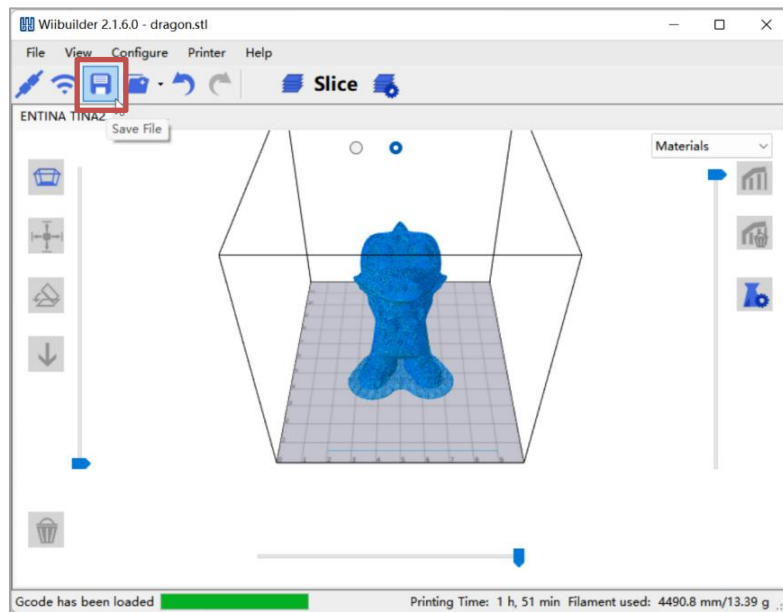

5.8. Send Files by USB

1. Connect the 3D printer and computer with a USB cable. The CH340 driver should be installed first. Click "Connect Printer".

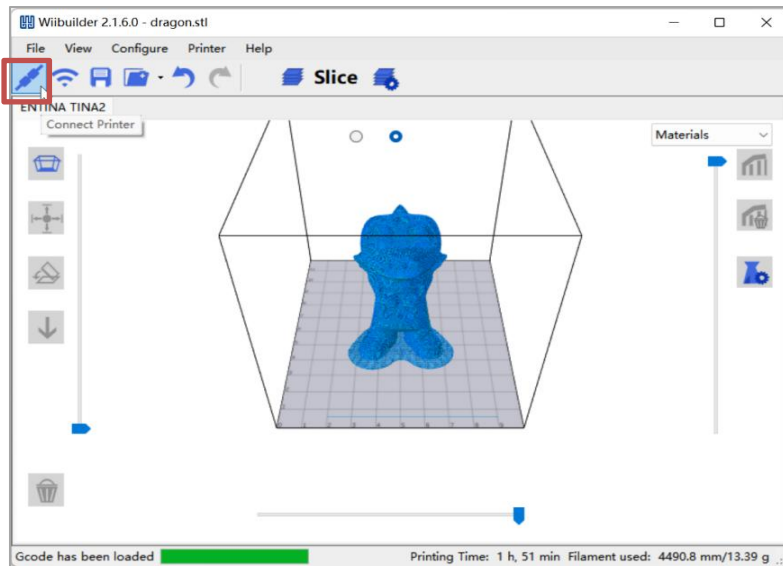

2. Click "Connect". Click "Upload And Print", the model will start printing.

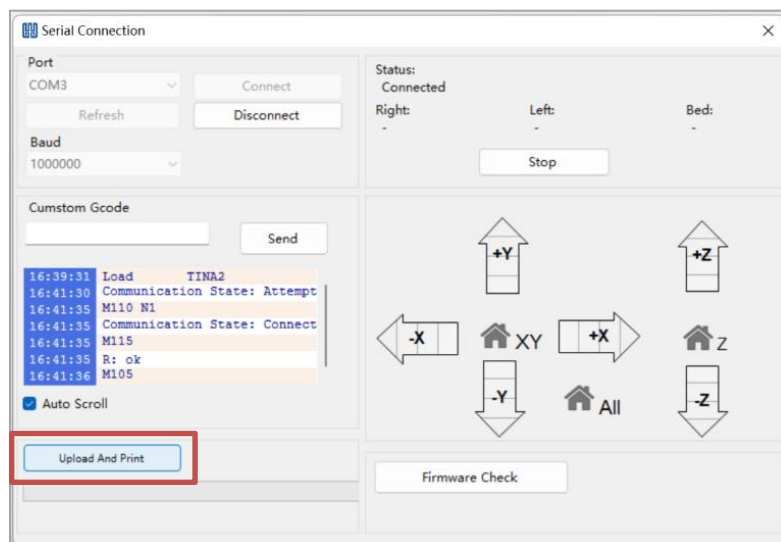
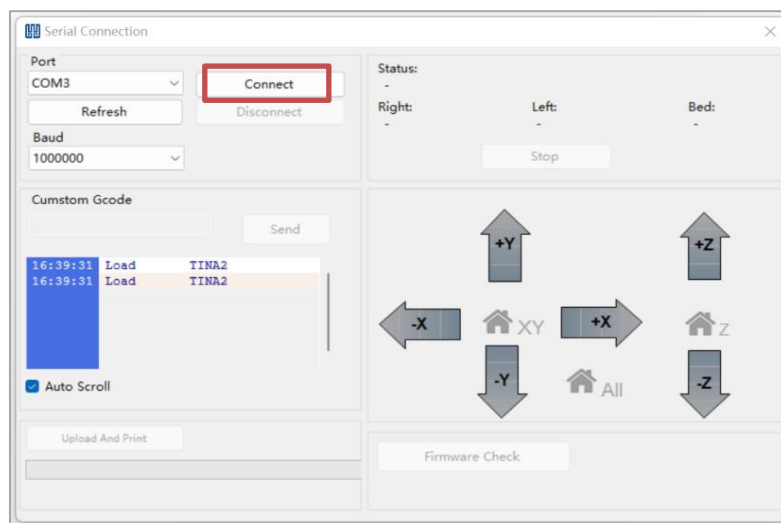

5.9. Advanced Parameter Settings

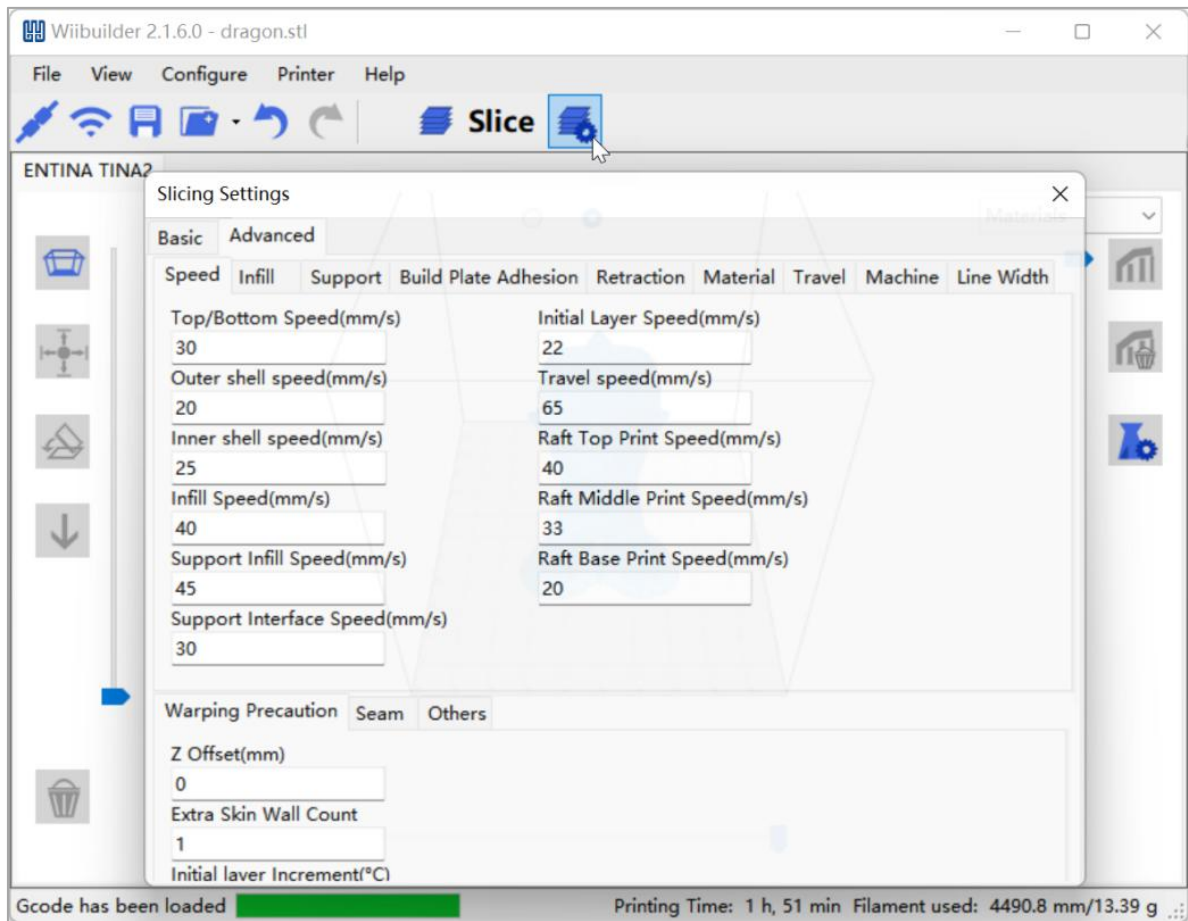

5.9.1. Speed Tab

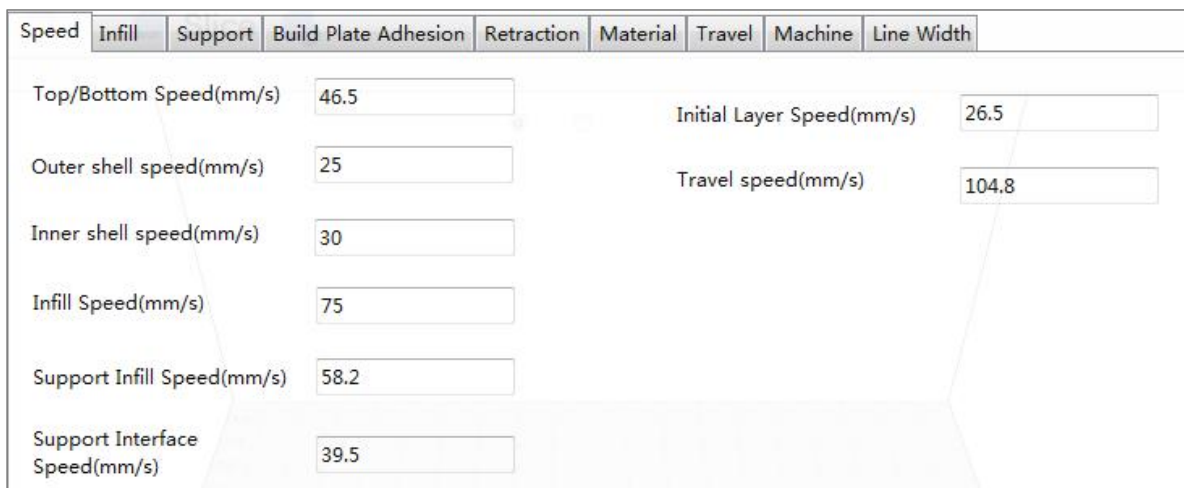

The **Speed Tab** features the following options:

- **Top/Bottom Speed (mm/s):** Sets the printing speed of the top and bottom surfaces of the model.
- **Outer shell speed (mm/s):** Sets the printing speed of the external shell surfaces.
- **Inner shell speed (mm/s):** Sets the printing speed of the internal shell surfaces.
- **Infill Speed (mm/s):** Sets the printing speed of the infill inside the model.

- **Support Infill Speed (mm/s):** Sets the printing speed of infill inside the model supports.
- **Support Interface Speed (mm/s):** Sets the printing speed of the top and bottom surfaces of the model supports.
- **Initial Layer Speed (mm/s):** Sets the printing speed of the first layer of the model.
- **Travel speed (mm/s):** Sets the movement speed of the nozzle when not printing.

5.9.2. Infill Tab

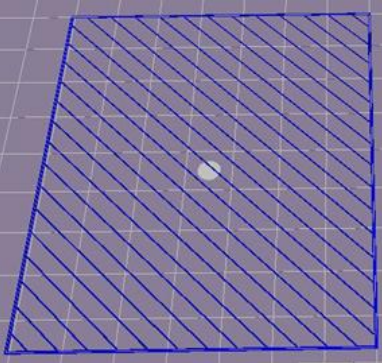
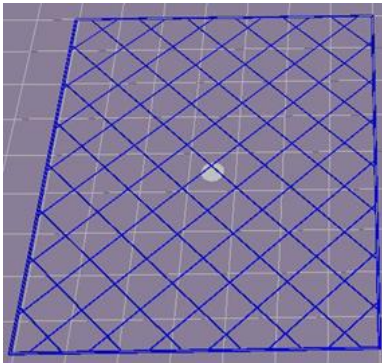
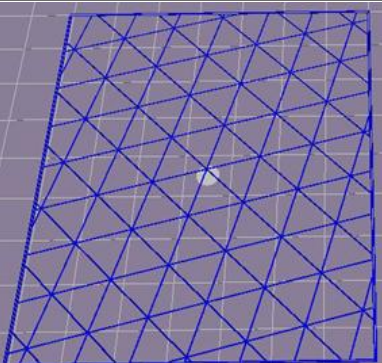
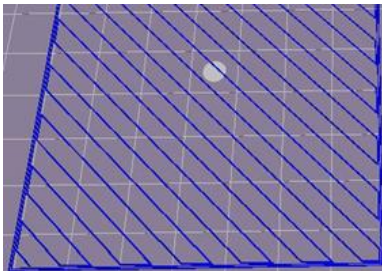

- **Infill Pattern:** Use the drop-down menu to select one of seven different infill patterns, including **Lines**, **Grid**, **Triangles**, **Zig Zag**, **Concentric**, **Cross**, and **Octet**. The individual patterns are illustrated in the table below.
- **Infill Before Wall:** Check this box to print the model after filling and printing the outline.
- **Outer Before Inner Walls:** Check this box to print the exterior walls before printing the interior walls.

Infill Patterns	
	
Lines	Grid
	

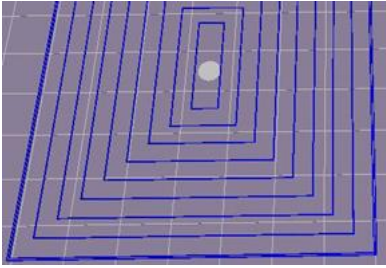
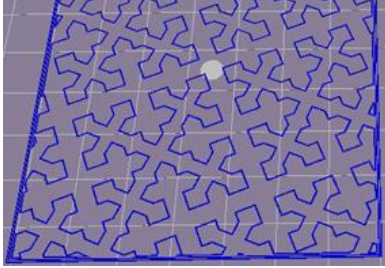
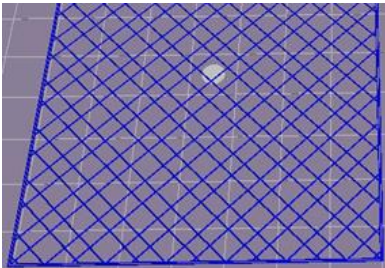
Triangle	Zig Zag
	
Concentric	Cross
	
Octet	

5.9.3.Support Tab

Speed	Infill	Support	Build Plate Adhesion	Retraction	Material	Travel	Machine	Line Width
Support Pattern:		Zig Zag	Enable Support Interface		<input checked="" type="checkbox"/>			
Overhang angle for support(°):		60	Support Top Thickness(mm)		0.8			
Support infill density(%):		10	Support Bottom Thickness(mm)		0.8			
Support Top Gap(mm):		0.18	Support Interface Density(%)		70			
Support Bottom Gap(mm):		0.1	Support Interface Infill Pattern		Lines			
Distance X/Y(mm):		0.7	Connect Support		<input type="checkbox"/>			

- **Support Pattern:** Use the drop-down menu to select one of five support patterns, including **Lines**, **Grid**, **Triangles**, **Zig Zag**, and **Concentric**. The pattern designs are the same as those of the infill patterns of the same name.
 - **Lines** support is easier to remove and is used on models that require more support.
 - **Grid** support is used on small models, which need fewer supports.
 - **Zig Zag** support is used for models that are particularly difficult to remove. It is stronger than Lines support and is better than Grid support.

- **Overhang angle:** The overhang angle is the angle between the support and the surface of the model. Larger settings make the supports easier to remove, while smaller settings provide better support. The default angle is 60 degrees.
- **Support infill density (%):** Determines the infill density for supports. The higher the density, the stronger the supports.
- **Support Top Gap (mm):** The distance between the top of the support and the model surface. The smaller the distance, the more effective the support, but is more difficult to remove from the model surface, resulting in residual material on the model surface. The larger the distance, the less effective the support, but is easier to remove from the model surface, resulting in a smoother surface.
- **Support Bottom Gap (mm):** The distance between the bottom of the support and the model surface. The effects of this parameter are the same as the effects of the **Support Top Gap (mm)** parameter.
- **Distance X/Y (mm):** The distance between the support and the model surface in the horizontal plane. The effects of this parameter are the same as the effects of the **Support Top Gap (mm)** parameter.
- **Enable Support:** Check this box to use supports.
- **Support Top:** Determines the thickness of the top layer of the supports.
- **Support Bottom:** Determines the thickness of the bottom layer of the supports.
- **Support Interface:** Sets the percentage of infill used inside the supports.
- **Support Interface Infill Pattern:** Use this drop-down menu to choose one of five infill patterns for the supports, including **Lines**, **Grid**, **Triangles**, **Zig Zag**, and **Concentric**. The pattern designs are the same as those of the infill patterns of the same name.
- **Connect Support:** Check this box to connect separate supports into one part.

5.9.4. Build Plate Adhesion Tab

Speed	Infill	Support	Build Plate Adhesion	Retraction	Material	Travel	Machine	Line Width
			Raft Air Gap(mm)	0.24		Brim line amount	20	
			Raft Extra Margin(mm)	5		Skirt Line Count	1	
			Raft Base thickness(mm)	0.3				
			Initial Layer Z Overlap	0.09				

- **Raft Air Gap (mm):** The distance between the raft and the model. This determines the difficulty of removing the raft from the model.

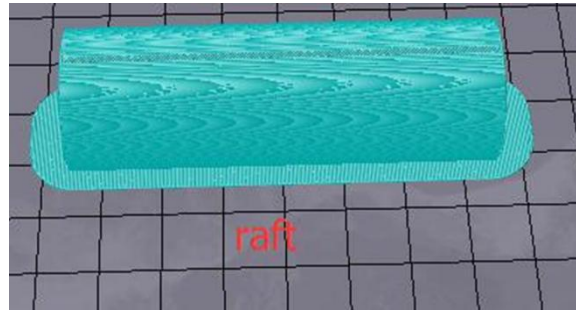

- **Raft Extra Margin (mm):** The distance between the edge of the raft and the model surface.
- **Raft Base thickness (mm):** Determines the thickness of the raft.
- **Initial Layer Z Overlap:** Determines the amount of overlap between the first and second layers of the model.
- **Brim line amount:** Sets the number of ring gaskets that are added to the edge of the model in contact with the build platform.

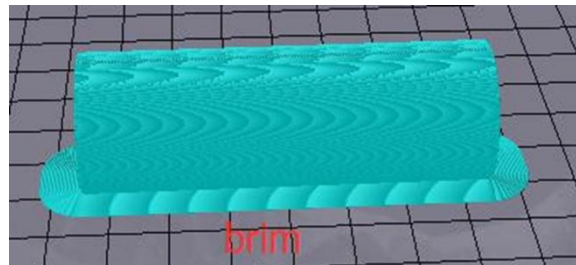

- **Skirt Line Count:** Sets the number of anti-overflow lines at the end of the model in contact with the build platform.

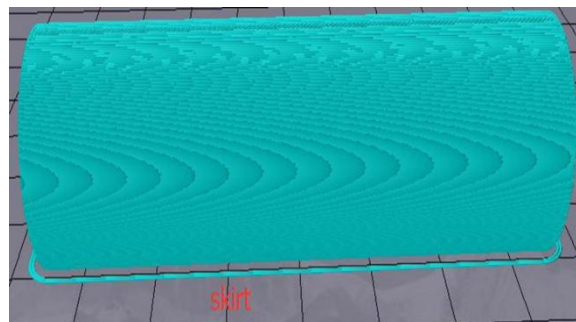

5.9.5.Retraction Tab

Speed	Infill	Support	Build Plate Adhesion	Retraction	Material	Travel	Machine	Line Width
Horizontal Travel Retraction		<input checked="" type="checkbox"/>	Z Hop When Retracted		<input checked="" type="checkbox"/>			
Retract at Layer Change		<input type="checkbox"/>	Z Hop Height(mm):		<input type="text" value="0"/>			
Retraction speed(mm/s):		<input type="text" value="28"/>						
Retraction distance(mm):		<input type="text" value="1.2"/>						
Retraction Minimum Travel(mm):		<input type="text" value="0.8"/>						

- **Horizontal Travel Retraction:** Check this box to enable filament retraction when the nozzle is not printing and is moving in a horizontal direction.
- **Retract at Layer Change:** Check this box to retract the filament when switching from layer to layer.
- **Retraction speed (mm/s):** Sets the speed at which filament is retracted.
- **Retraction distance (mm):** The distance the filament is retracted within the nozzle.
- **Retraction Minimum Travel (mm):** Sets the minimum nozzle movement distance before printing and before retracting the filament.
- **Z Hoe When Retracted:** Check this box to enable lift the nozzle when filament is returned after retraction.
- **Z Hop Height (mm):** The distance the nozzle is lifted when filament is returned after retraction.

5.9.6. Material Tab

Speed	Infill	Support	Build Plate Adhesion	Retraction	Material	Travel	Machine	Line Width
Filament flow(%):		95						
Filament Diameter(mm):		1.75						

- **Filament flow (%):** Sets the flow rate of filament in the melting state. This is set according to the type of filament being used. In general, the flow rate for PLA or PLA Pro is 90 and the flow rate of ABS is 100.
- **Filament Diameter (mm):** Sets the diameter of the filament being used. This printer only supports 1.75mm diameter filament.

5.9.7. Travel Tab

Basic		Advanced						
Speed	Infill	Support	Build Plate Adhesion	Retraction	Material	Travel	Machine	Line Width
Combing Mode								
Off								

- **Combing Mode:** This option determines how the nozzle will move when not printing. The **Off** option has the nozzle move the shortest distance between the previous extrusion location and the new start location. The **All** option causes the nozzle to move along anything

it has already extruded. The **No Skin** option will avoid the outer layers to move the nozzle to the new start location, which can greatly improve print quality.

5.9.8.Machine Tab

Basic	Advanced							
Speed	Infill	Support	Build Plate Adhesion	Retraction	Material	Travel	Machine	Line Width
Right Nozzle Diameter(mm)								
0.4								

- **Right Nozzle Diameter (mm):** Sets the diameter of the nozzle on the right extruder. This printer only has a single extruder, which is designated the right extruder. The nozzle diameter of this printer is 0.4mm.

5.9.9.Line Width Tab

Speed	Infill	Support	Build Plate Adhesion	Retraction	Material	Travel	Machine	Line Width
Outer Wall Line Width(mm)		0.4		Skirt/Brim Line Width(mm)		0.4		
Inner Wall(s) Line Width(mm)		0.4		Raft Top Line Width(mm)		0.4		
Top/Bottom Line Width(mm)		0.4		Raft Middle Line Width(mm)		0.7		
Infill Line Width(mm)		0.5		Raft Base Line Width(mm)		0.8		
Support Line Width(mm)		0.4		Prime Tower Line Width(mm)		0.4		

- **Outer Wall Line Width (mm):** This is the width of the outermost wall line. By lowering this value, higher levels of detail can be printed.
- **Inner Wall(s) Line Width (mm):** This is the width of a single wall line for all walls except the outermost wall.
- **Top/Bottom Line Width (mm):** This is the width of the top and bottom lines.
- **Infill Line Width (mm):** This is the width of a single infill line.
- **Support Line Width (mm):** This is the width of a single support structure line.
- **Skirt/Brim Line Width (mm):** This is the width of a single skirt or brim line.
- **Raft Top Line Width (mm):** This is the width of the lines in the top surface of the raft. These lines can be thin so that the top of the raft is smooth.

- **Raft Middle Line Width (mm):** This is the width of the lines in the middle raft layers. Making the second layer extrude more causes the lines to stick to the build plate.
- **Raft Base Line Width (mm):** This is the width of the raft base layer. These should be thick lines to assist with build plate adhesion.
- **Prime Tower Line Width (mm):** This is the extrusion width of the prime tower.

5.9.10. Seam Tab

Note: The Z Seam is where the 3D printer finishes its motion when printing the skin (outside layer) of a model. This can result in a small blob or zit where the 3D printer changes the Z height. If in alignment, there can be a noticeable line up the side of the print, referred to as a Z Seam, because the filament continues to ooze at the start/stop location. The options on this screen are used to mitigate this effect.

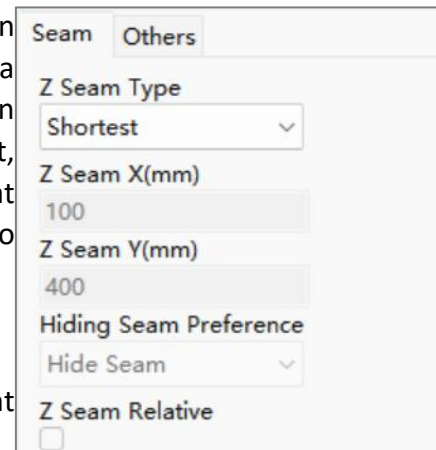

- **Z Seam Type:** Determines where the Z Seam will appear.
 - **Shortest:** This option selects the most time efficient start/stop location.
 - **User Specified:** This option allows you to specify the X and Y start/stop location, which determines where the Z Seam will appear.
 - **Random:** With this option, the 3D printer will randomly choose the start/stop location, which prevents building a column.
 - **Sharpest Corner:** The start/stop location and the Z Seam will appear in the sharpest corner of the model.
- **Z Seam X (mm):** This option is the X location of the Z Seam. This option can only be set when the Z Seam Type is set to **User Defined**.
- **Z Seam Y (mm):** This option is the Y location of the Z Seam. This option can only be set when the Z Seam Type is set to **User Defined**.
- **Hiding Seam Preference:** This option is only available when the Z Seam Type is set to **Sharpest Corner**. It determines whether the Z Seam will be on the inside or outside of the corner.
- **Z Seam Relative:** Checking this box will set the Z Seam in respect to the object's center, whereas leaving the box unchecked will set the Z Seam along the absolute position on the build plate. This option is only available when the Z Seam Type is set to **User Defined**.

5.9.11. Others Tab

- **Skin Layers Thickness (mm):** This option determines the thickness of the top and bottom skin layers.
- **Horizontal Expansion (mm):** Thermoplastics tend to shrink when cooling. This option allows you to fine tune the part size to offset shrinkage for prints that require tighter tolerances.

- **Skin Alternate Rotation:** Typically, a 3D printer will print solid layers for the top and bottom layers. When doing this, it changes direction 90 degrees from layer to layer. This setting changes that behavior to add an additional 45 degrees of rotation every two layers.

The following images illustrate the normal print direction of the first three layers.

Seam
Others

Skin Layers Thickness(mm)

Initial Layer Horizontal Expansion(mm)

Hole Horizontal Expansion(mm)

Enable Print Cooling

Enable Draft Shield

Wall Line Count

Extra Skin Wall Count

Outer Wall Inset(mm)



The following image illustrates the print direction of layer three when the **Skin Alternate Rotation** option is enabled.



- **Enable Print Cooling:** When enabled, cooling air will be directed at the printed part.
- **Enable Draft Shield:** When enabled, this printer will print a wall around the model to prevent environmental breezes or drafts from affecting the cooling. This is typically used when **Enable Print Cooling** is disabled for filament that needs a longer cooling time, such as ABS.
- **Wall Line Count:** This option determines the number of walls to print.

6. CURA

6.1. Installation

Cura is another good slicing software program for use with the WEEDO Tina2S 3D Printer. Unlike models sliced with Wiibuilder, models sliced with Cura cannot be previewed on the File Information screen. For your convenience, a customized version of the Cura installer is included on the microSD™ card for both the Windows® and Mac® OS X® operating systems.

6.1.1. Installation in Windows

To install Cura, double click the exe file for Windows on the microTF card, then perform the following steps:

1. The first screen is a **Welcome** dialog. Click the **Next >** button to display the License **Agreement** dialog. Click the **I Agree** button to continue.

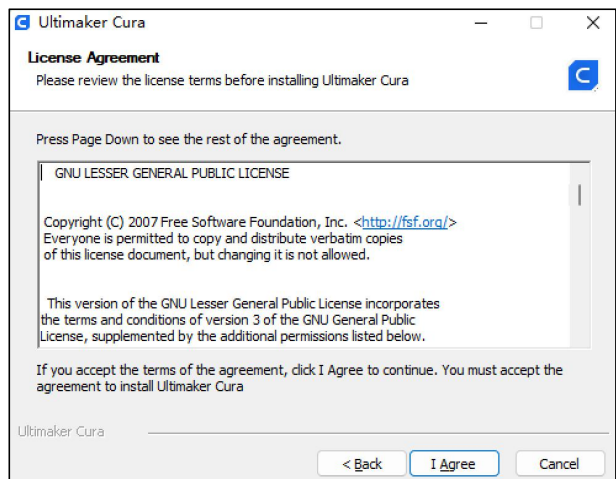

2. The installer will prompt you to select the directory to which Cura will be installed. If you don't want to use the default directory, click the **Browse...** button, then select your preferred directory. Click the **Next >** button to continue.

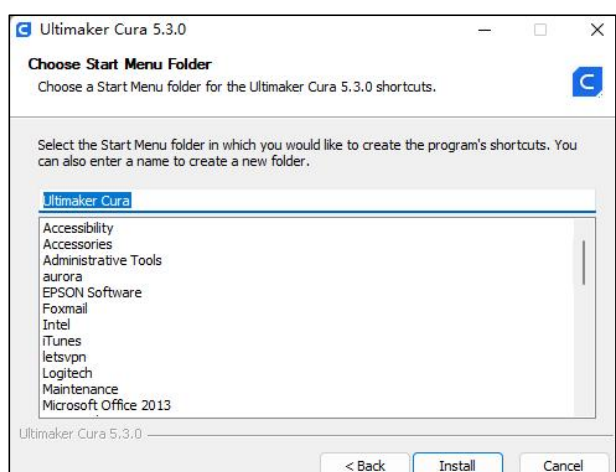
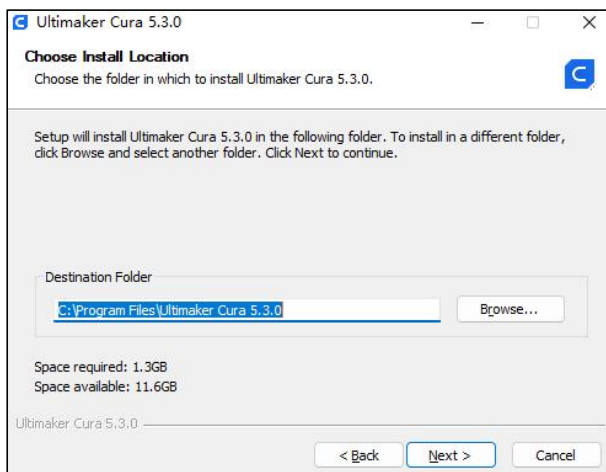

3. By default, the STL file extension will be associated with Cura. Select the file types you want to associate with Cura, then click the **Install** button to continue. If you are prompted by Windows Security to approve a driver installation, click the **Install** button to continue. Ensure that the check box to the left of Run Ultimaker Cura is checked, then click the **Finish** button to continue.

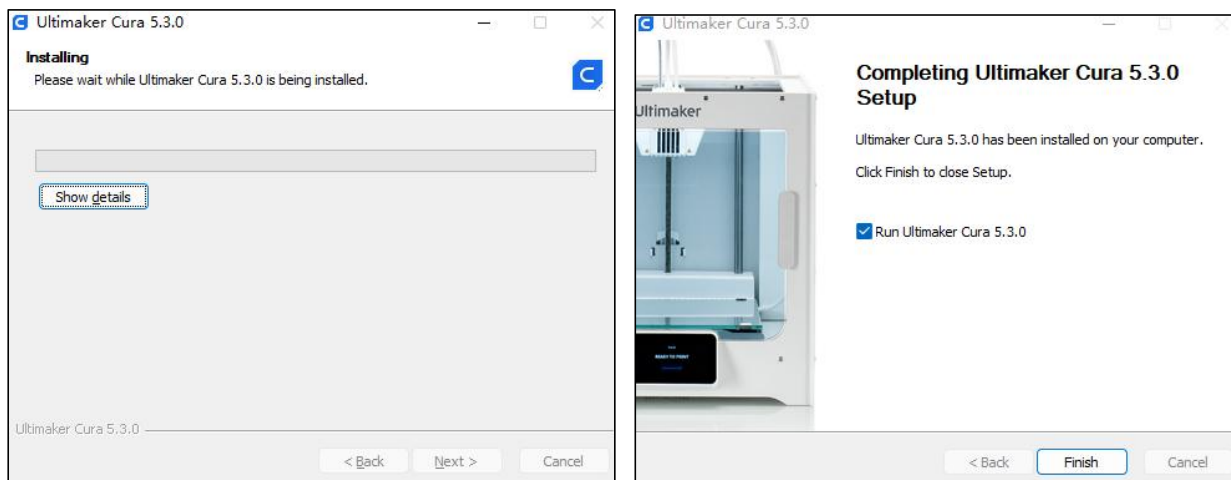

4. Once Cura launches, you will see a **Welcome** dialog, followed by a **User Agreement** dialog. Click **Get Started** on the **Welcome** dialog, then click **Agree** on the **User Agreement** dialog to continue. If you have already installed Cura on this computer, you will instead be left on the main screen. If this is the case, skip ahead to step 6.

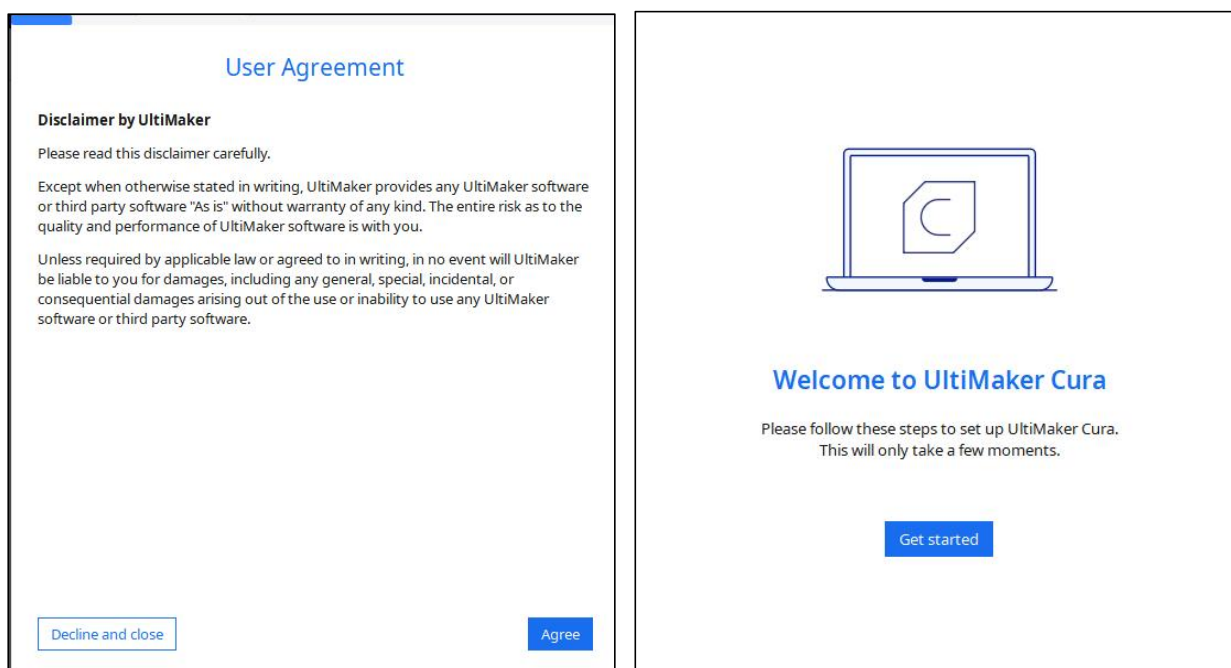

5. Click the **Next** button on the next two dialogs to continue.

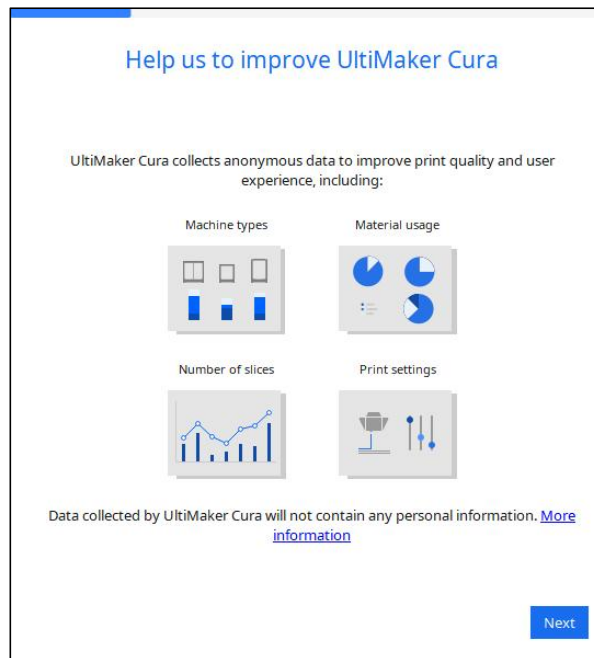

6. The **Ultimaker Cloud** dialog tells you about the cloud and allows you to **Create an account** or **Sign in**. Click the **Skip** button to complete the installation and basic setup.

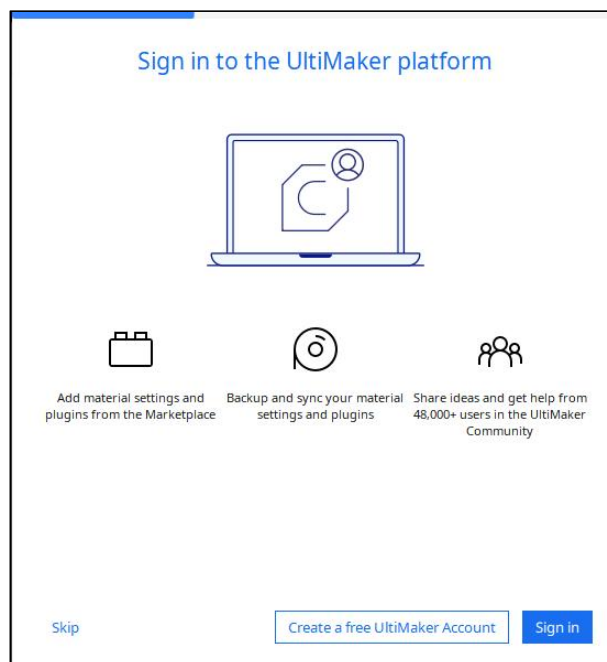

7. On the **Add printer** dialog, click the caret to the right of the **Add a networked printer** label, then click the caret next to the **WEEFUN** label. Click the radio button next to the **WEEFUN D120** option, then click the **Next** button to continue.

If you skipped to this step because the **First time run** wizard is bypassed, click **Settings > Printer > Add Printer...** to display the **Add a printer** dialog. Click the radio button to the left of the **WEEDUN D120** option, then click the **Add** button. Skip ahead to step 8.

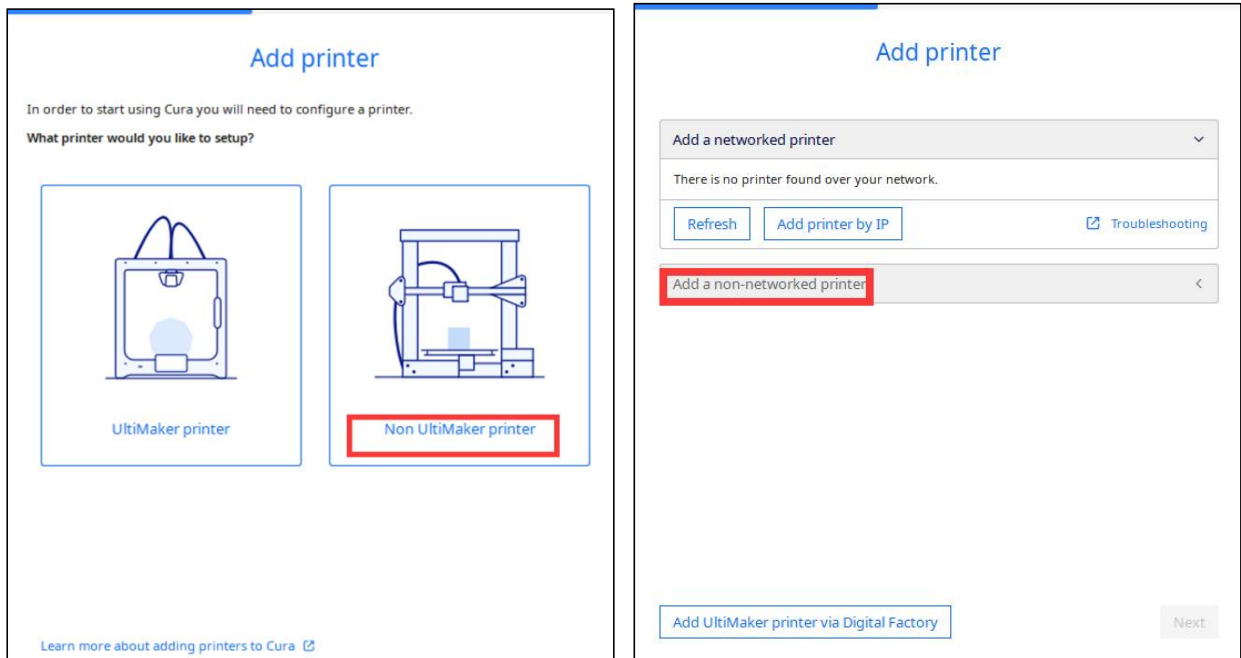

8. Cura will finish launching and leave you on the main screen. The basic parameters have all been set to work with the WEEDO Tina2S. If you want to change or customize the parameters, click the pencil icon in the upper right corner, then select Custom to change the settings you need to change.

Note that the Infill density, Support type, and Platform adhesion type options should be set according to the needs of the model you are printing.

The Infill density will determine the overall strength of the finished object. If printing a decorative object, a low fill density is appropriate. However, if printing an object that will be used as a tool or part (e.g., a gear), a high fill density will impart maximum structural strength to the finished object.

If printing something with no overhang, such as a cube, you can set the Support type to None. If the model has areas that overhang the build plate, but which are not overhanging a lower section, you can use the Touching build plate option. The

Everywhere option is usually only necessary for very complex models with parts that overhang other parts.

In most cases, the Brim option for the Platform adhesion type is sufficient and is easier to remove and clean up. The Raft option builds a flat layer on which the model is then built that will need to be removed once the print is complete.

Feel free to experiment with these options to achieve the best possible print.

Congratulations! Cura is now installed and ready for use. Refer to the Cura documentation for operating details and information about the various options.

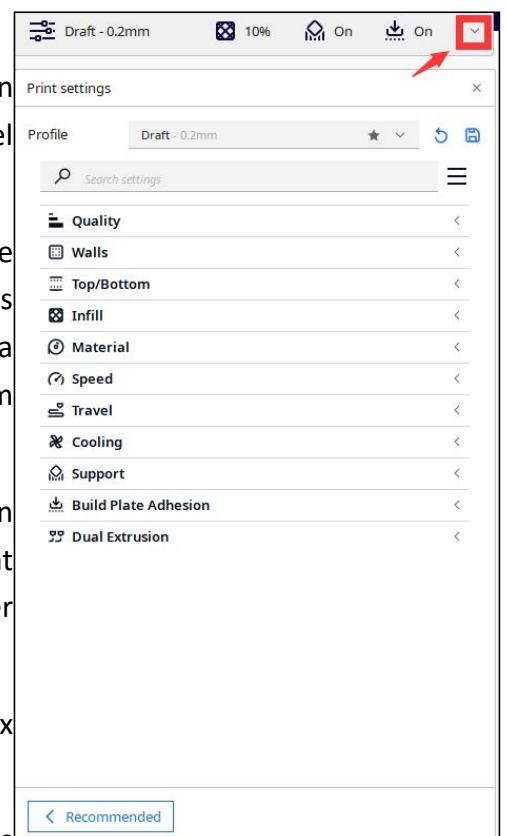

6.1.2. Installation in MacOS

Decompress the installation. Double-click to run the software installation package, drag Cura into the application, and it will be displayed.

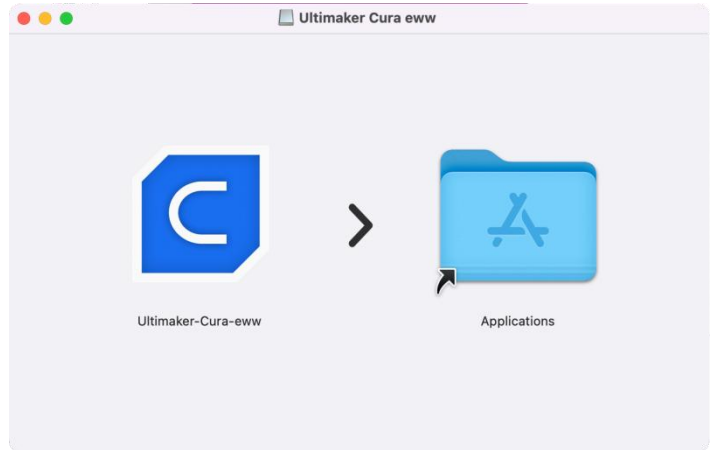
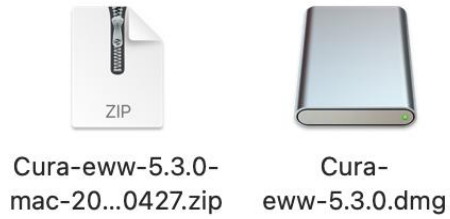

6.2. Interface Introduction

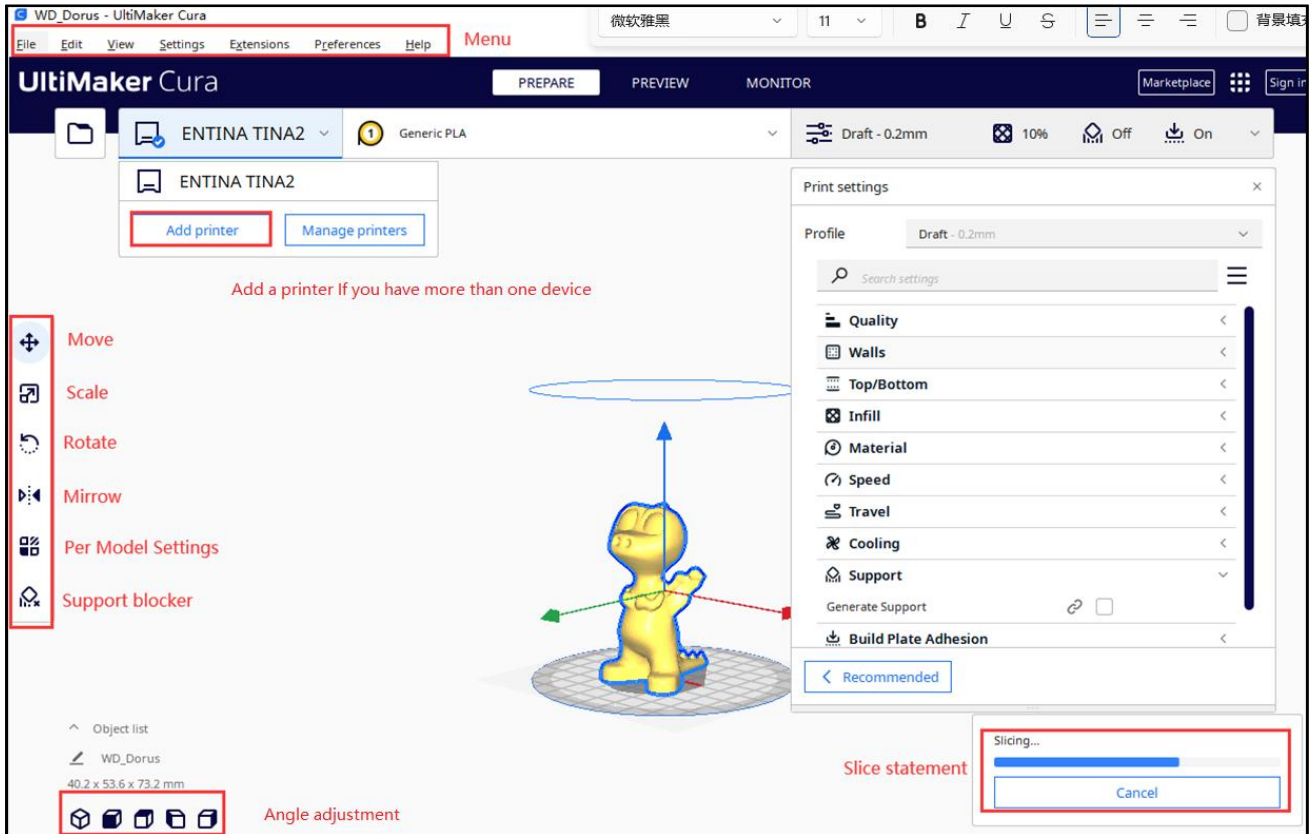

- Menu Bar: Open the Cura menu
- Move, Scale, Rotate, Mirror: Change the size and position of the model
- Support Blocker: Add manual support to the model

Right-click on the model to open the context menu:

- Center Selected: automatically adjust the XY coordinates of the model and place the model in the middle of the platform
- Delete Selected: delete the currently selected model
- Multiply Selected: Choose the multiple parts if your model has
- Arrange All Models: automatically adjust the position and spacing of multiple models on the platform
- Clear Build Plate: delete all models on the platform

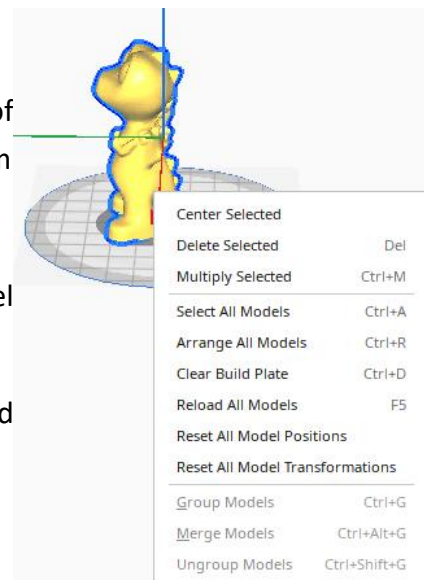

6.3. Add Model

Open Cura, click "File" to load the model, or just drag the model into it.

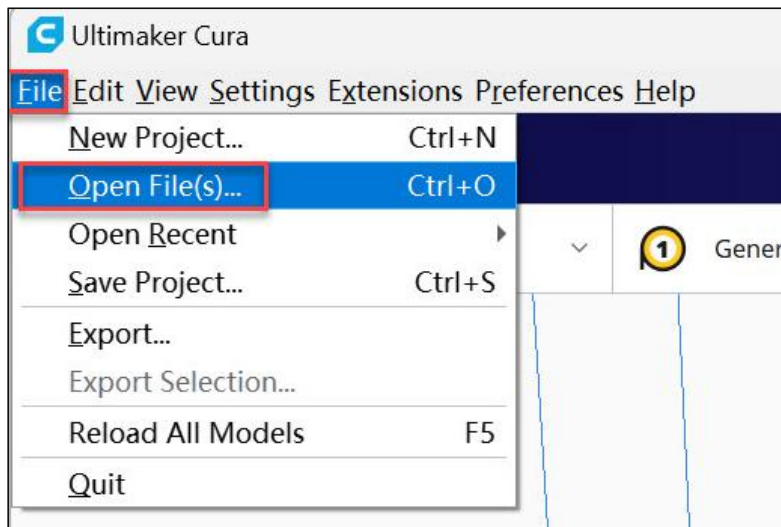

6.4. Adjust The Model

Click the model to adjust the size, angle, and position.

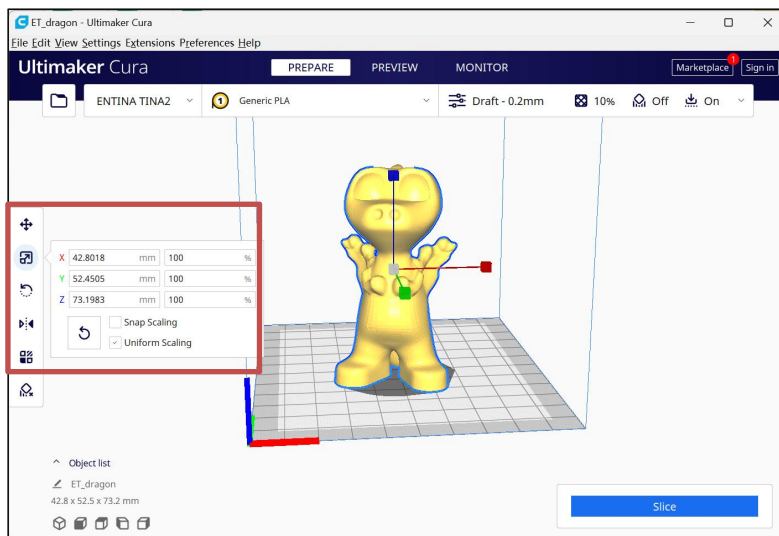

6.5. Slice

Novice users can directly use the default parameters without adjustment.

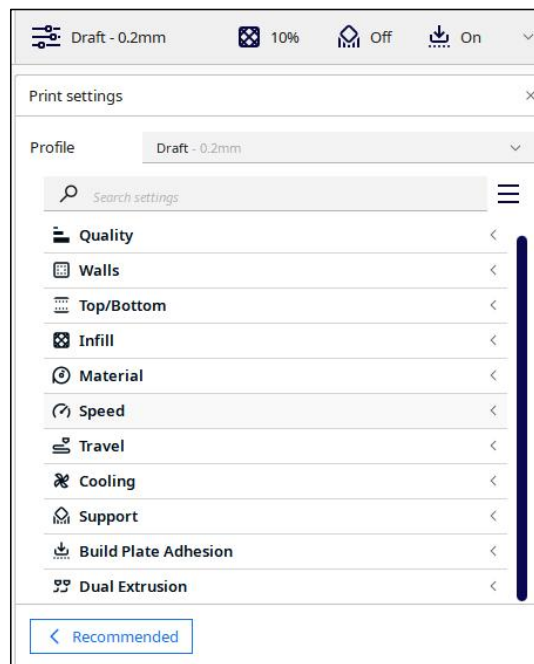

After setting the corresponding parameters, click "Slice" to convert the file.

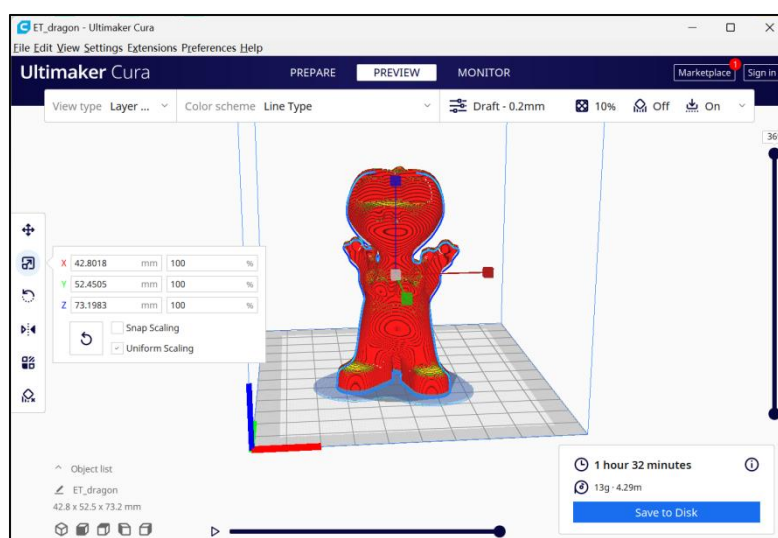
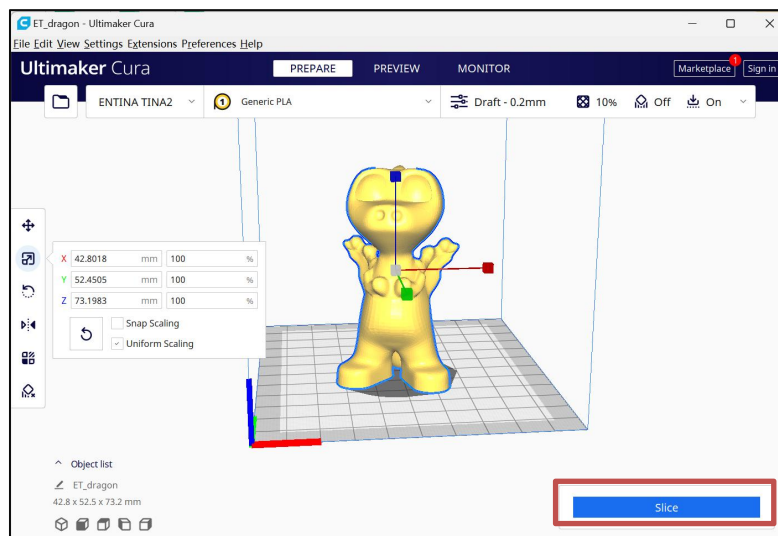

6.6. Send files by the Network

Before sending the print file through the network, make sure that the 3D printer is connected to the network, and the IP address is displayed. Please refer to: "**Print by app**".



1. click "manage printers"

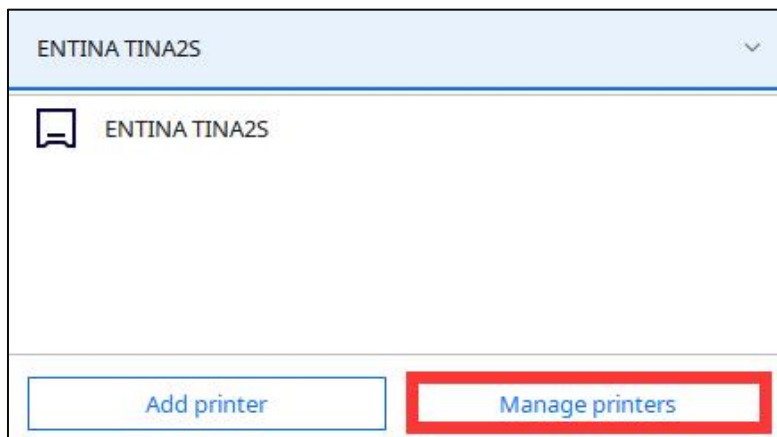

2. Choose "Connect Octoprint"

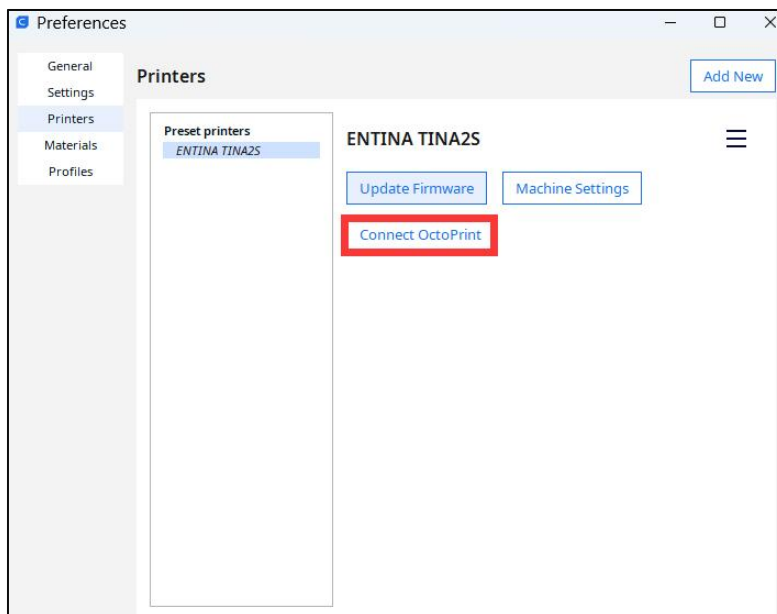

3. Enter the IP address and click **ok** to connect.

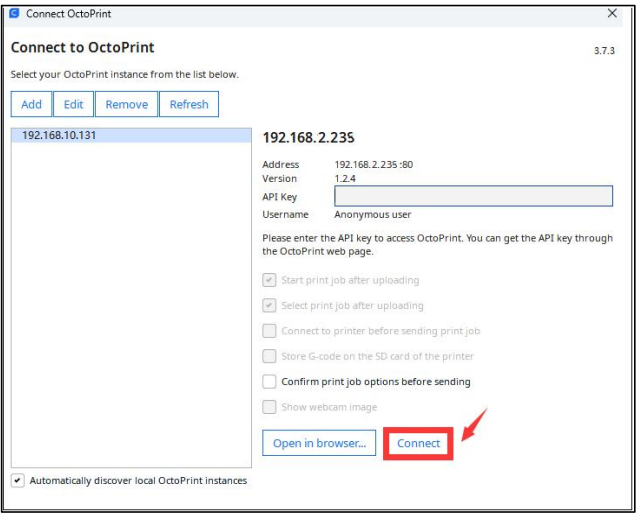
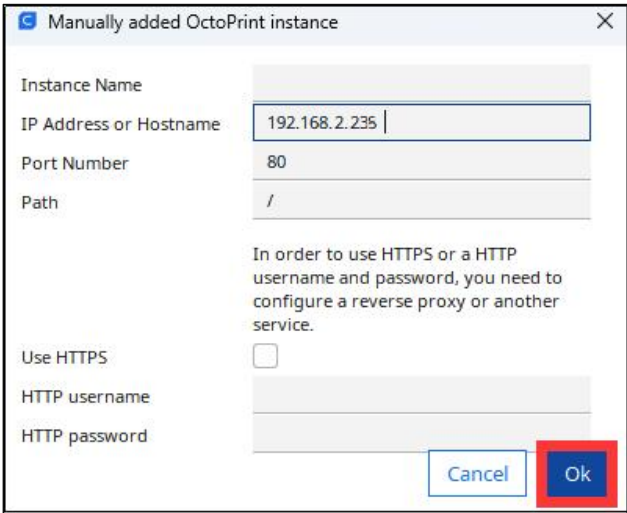
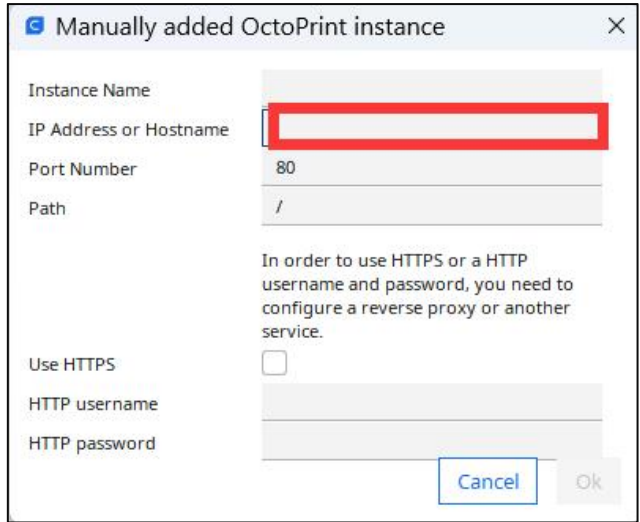
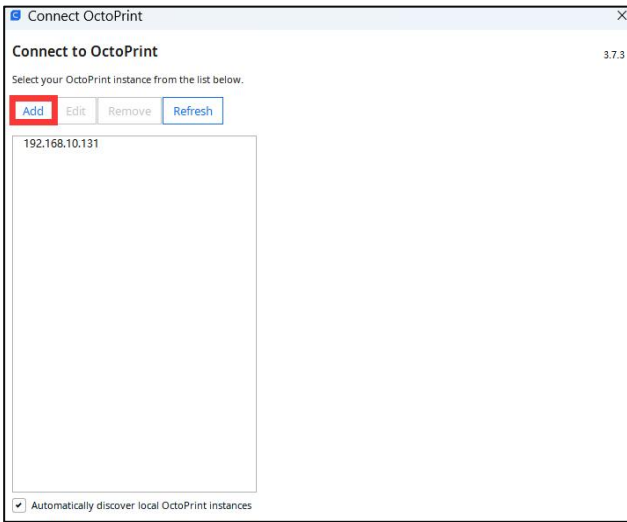

6.7. Send Files by TF card

Save the sliced model to the TF card, insert the TF card into the printer and print.

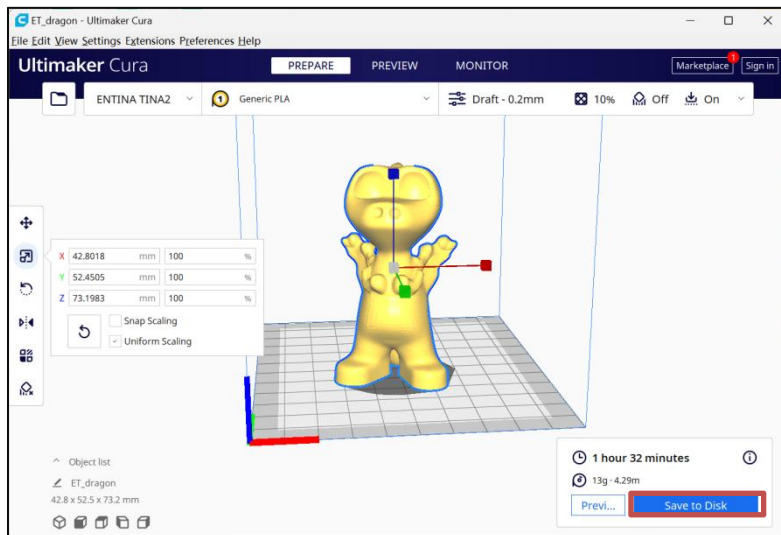

7. PRINT BY APP

1. Download and install the APP : PoloPrint Cloud
2. Register or log in to the APP.
3. Configure WiFi for 3D printer.

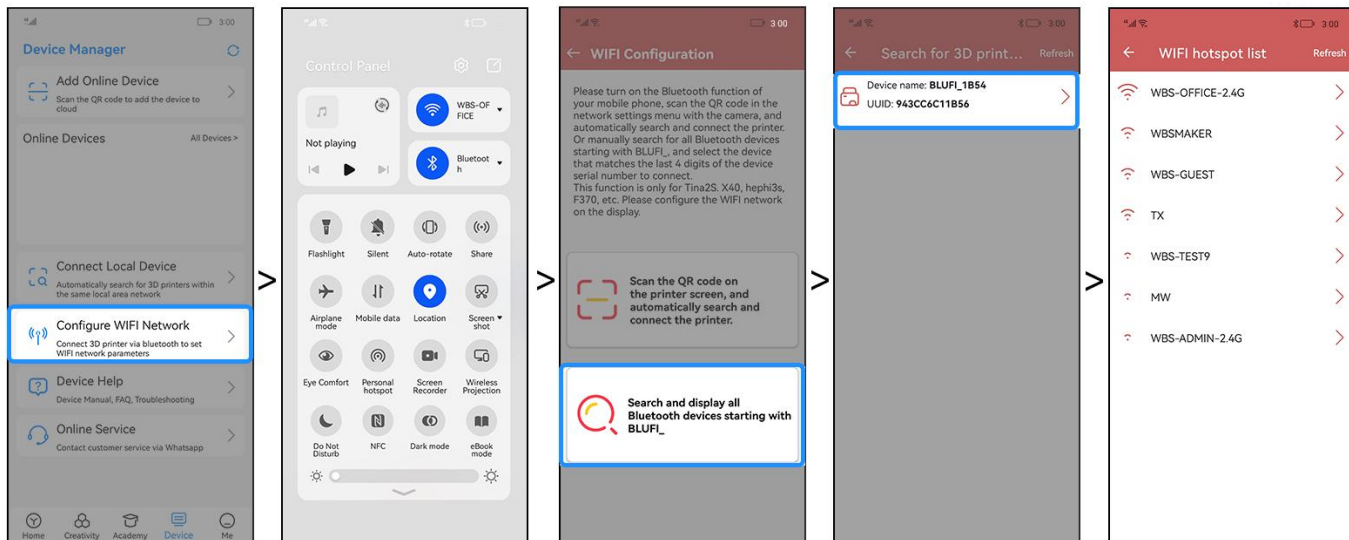

4. Get the "Wifi QR Code".

NOTE: THE 3D PRINTER HAS BEEN CONNECTED TO THE NETWORK, AND THE IP ADDRESS IS DISPLAYED. FOR OPERATIONS, PLEASE REFER TO: "5. WIFI NETWORK".



5. Click "Add Online Device ", scan the QR code displayed on the screen, and submit the recognized SSID.

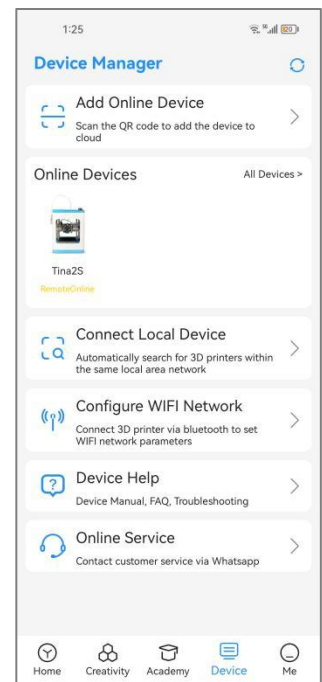
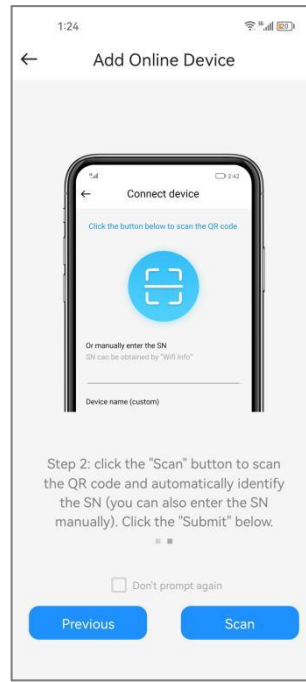
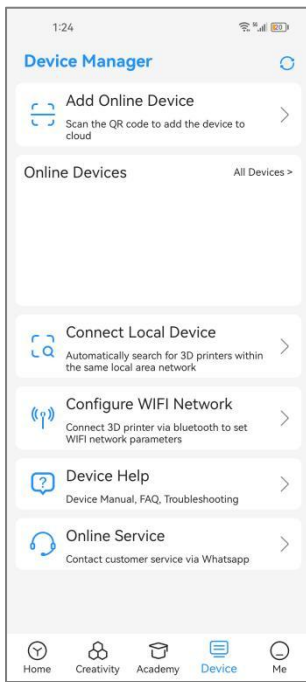

6. Select a model and click "Print".

