

Installation Instructions

Freestanding Tub Filler Faucet Manual

| CUPC Model # | Finish |
|----------------|-----------------------|
| 3817C-7-2F-CPR | Chrome |
| 3817C-7-2F-BLK | Matte Black |
| 3817C-7-2F-BNG | Brushed Nickel Glossy |
| 3817C-7-2F-BGM | Brushed Gold Matte |

| CUPC Model # | Finish |
|----------------|-----------------------|
| 3817C-7-2V-CPR | Chrome |
| 3817C-7-2V-BLK | Matte Black |
| 3817C-7-2V-BNG | Brushed Nickel Glossy |
| 3817C-7-2V-BGM | Brushed Gold Matte |

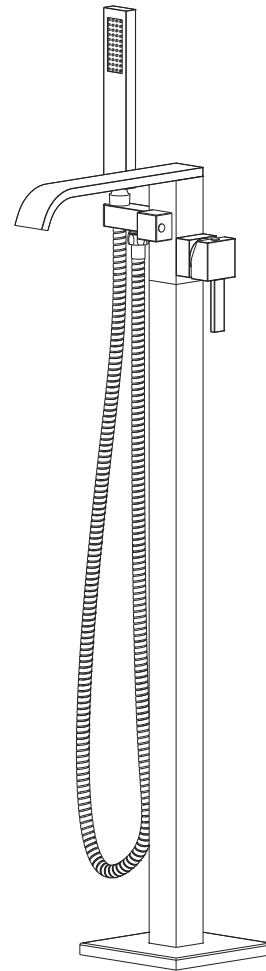
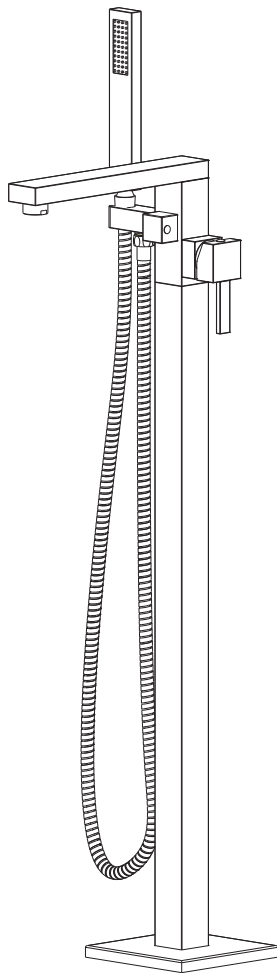

CALIFORNIA PROP 65 WARNING
WARNING! Cancer and Reproductive Harm
www.P65Warnings.ca.gov

ASME A112.18.1/CSA B125.1
 NSF61, NSF372
 ≤1.75 GPM (6.6L/min) at 60 psi c



Installation Instructions

 **READ ALL INSTRUCTIONS BEFORE UNPACKING THE PRODUCT** 

Important

- 1- For best results, we recommends that this unit be installed by a licensed, professional plumber.
- 2- Please read over these instructions thoroughly before beginning installation. Make sure that you have all tools and supplies needed to complete the installation.
- 3- Please flush the water system to ensure that no metal swarf, solder, and other impurities can enter the faucet that might damage the cartirdge. (Most of the leakages and water flow issues are from avoiding this very necessary step).
- 4- Turn off the hot and cold water lines at the angle valve and turn on the old faucet to release any built-up pressure.
- 5- Keep this booklet and the receipt (or other proof of date and place of purchase) for this product in a safe place. The receipt is required should it be necessary to request warranty parts.
- 6- Please keep the box and packaging materials until your product is completely installed and functional.

Cleaning and care

Clean the faucet often with a soft cloth to keep it looking like new. For heavy cleaning you can use mild liquid detergents or non-abrasive liquid polisher. Rinse with water and dry with a soft cloth. Avoid abrasive cleaners, steel wool and harsh chemicals as these will dull the finish and void your warranty.

Tools you may need



1. Drill

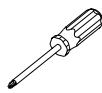

2. Phillips Screwdriver



3. Tape Measure



4. Pencil

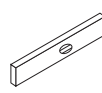

5. Level



6. Plumbers tape



7. Silicone/Caulk Gun



8. Adjustable wrench



9. Hammer

Installation

PARTS&COMPONENTS

| No | COMPONENT |
|----|---------------------|
| 1 | HANDLE |
| 2 | SCREW |
| 3 | BUTTON |
| 4 | DOME CAP |
| 5 | LOCKNUT |
| 6 | CARTRIDGE |
| 7 | BODY |
| 8 | CARTRIDGE |
| 9 | NUT |
| 10 | WASHER |
| 11 | AERATOR |
| 12 | AERATOR HOUSE |
| 13 | HANDLE |
| 14 | SCREW |
| 15 | BUTTON |
| 16 | O RING |
| 17 | SCREW |
| 18 | STRAIGHT PIPE |
| 19 | BASE |
| 20 | TRIANGLEBASE |
| 21 | SHOWER HOSE |
| 22 | FLEXIBLE HOSE (H/C) |
| 23 | HANLDE SHOWER |
| 24 | CHECK VALVE |
| 25 | EXPANSION SCREW |

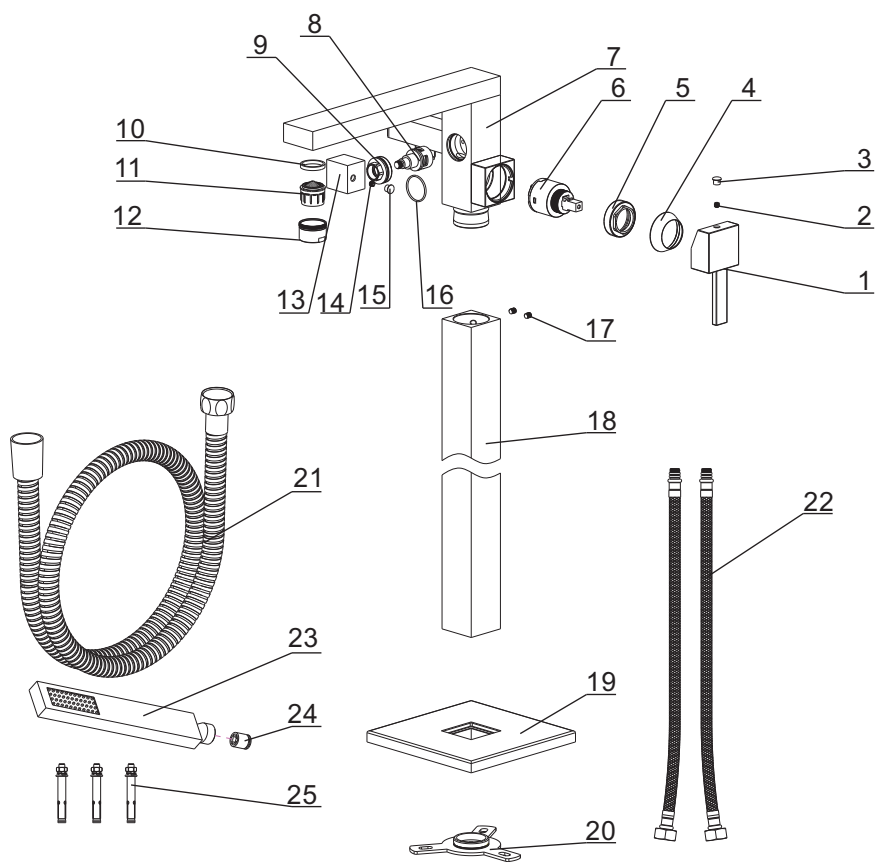

Installation

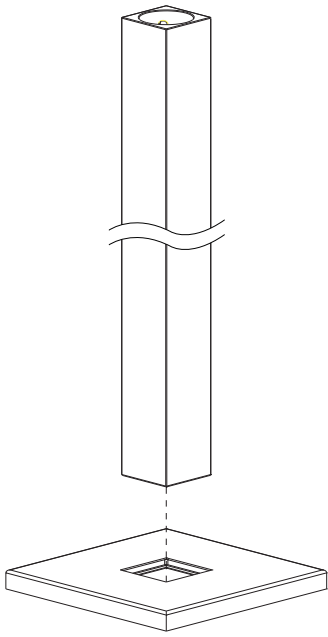

1. The Base Cover through the straight tube from top to bottom.

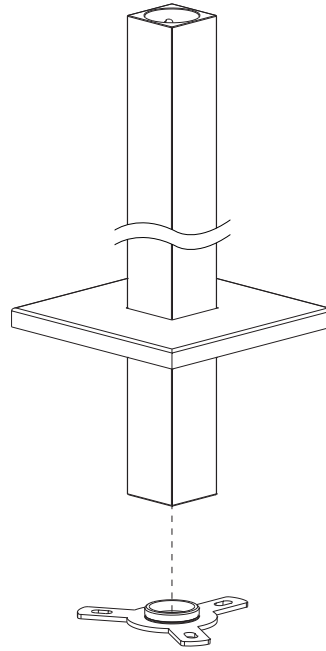

2. Install the permanent seat.

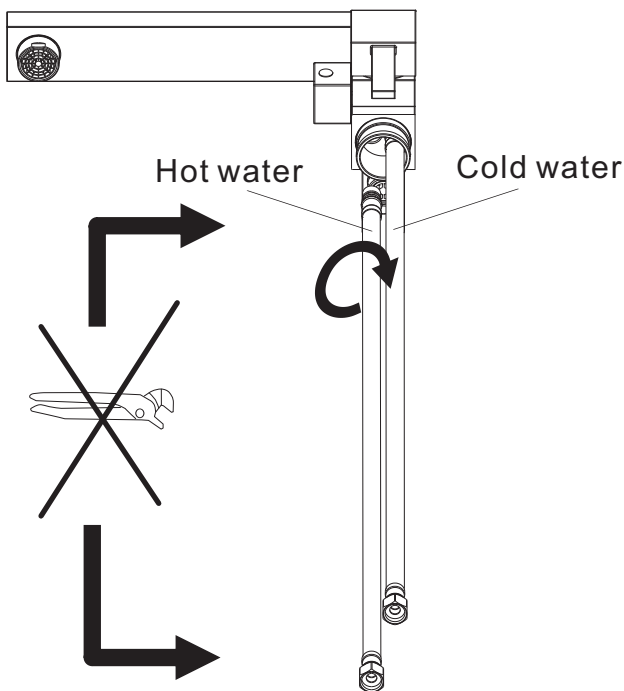

3. Distinguish the hot and cold hose and tighten the flexible hose by **HAND**.
DO NOT USE PLIER

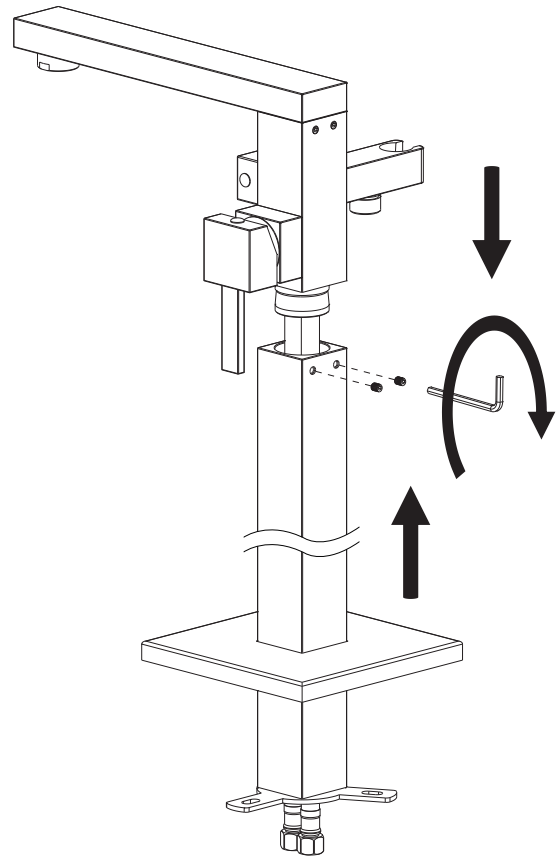

4. Insert faucet body assembly onto the faucet tube use two screws to fix them tightly. Make sure the flexible water supply lines go through the tube smoothly.

Installation

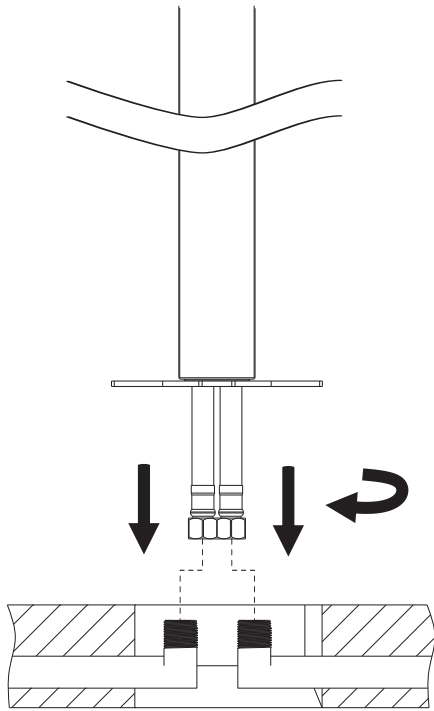

5. Install the hot-cold flexible hoses with valve.

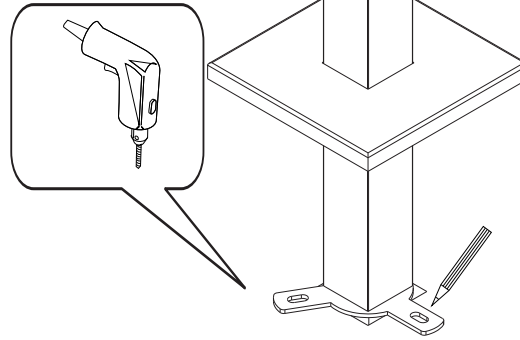

6. Mark 3 holes' position, and Drill the 3 holes.

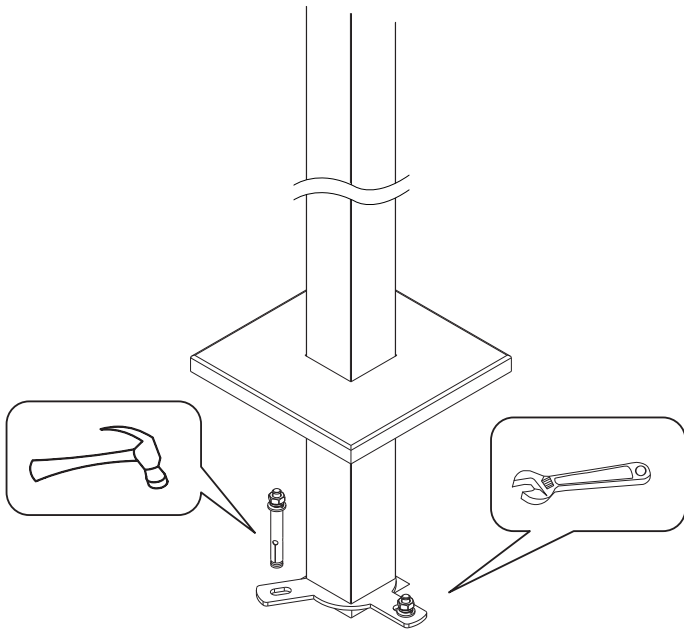

7. Secure the permanent seat on the floor using the attached 3 explosive screws, and Fix it by wrench.

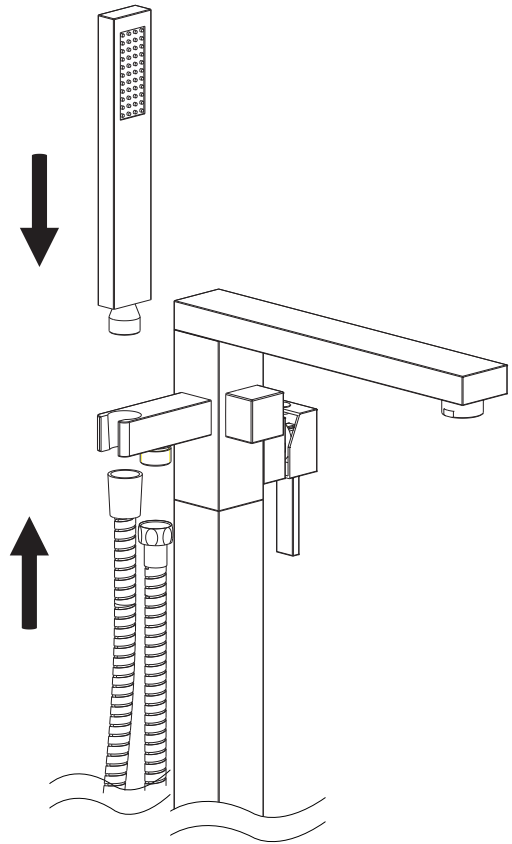

8. Install the hand shower hose.

Caution:

To ensure the tub filler is positioned correctly, **fully assemble the faucet with the triangular base before marking or drilling the floor holes.**

Mounting the base too early may cause the tub filler to become unstable or misaligned.