

INSIGNIA™

5.3 Cu. Ft. Freestanding Electric Range

NS-RGFE50WH26/NS-RGFE50SS26

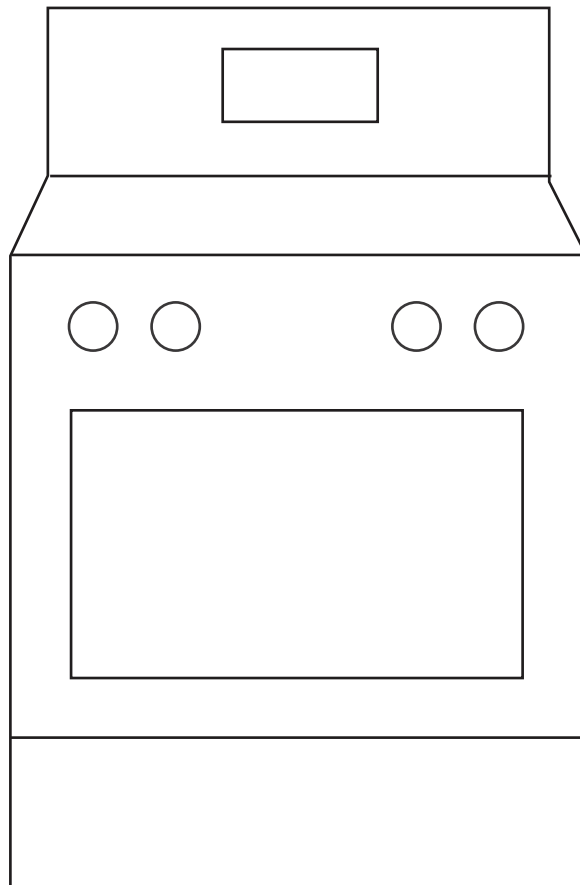

Before using your new product, please read these instructions to prevent any damage.
Most up-to-date *User Guide* is available from www.bestbuy.com

Contents

Introduction	3
Important Safety Instructions	3
Features	7
Dimensions	7
Understanding the cooking surface and surface controls	8
Using the glass-ceramic cooktop	8
Selecting the proper cookware for the ceramic cooktop	9
Understanding how various factors affect cooking	9
Understanding bakeware	9
Cooking conditions	10
Cooking results	10
Cookware materials	10
Using the surface elements	12
Understanding the types of cooktop elements	12
Setting a single element	12
Setting dual surface elements	13
Indicator lights	14
Using your oven	15
Using the oven controls	15
Setting the clock	16
Setting the timer	16
Using the oven racks	17
Baking in your oven	17
Broiling in your oven	19
Cooking tips	20
Surface cooking tips	20
Oven cooking tips	20
Care and cleaning of your range - general cleaning	21
Cleaning and maintaining the cooktop	22
Cleaning your oven	22
Removing and replacing the oven door	23
Replacing the oven light	24
Troubleshooting	25
Baking issues	25
General issues	25
Oven issues	26
Cooktop issues	26
Miscellaneous issues	27
Specifications	28
ONE-YEAR LIMITED WARRANTY	29

Introduction

Congratulations on your purchase of a high-quality Insignia product. Your NS-RGFE50WH26 or NS-RGFE50SS26 represents the state of the art in electric range design and is designed for reliable and trouble-free performance.

Important Safety Instructions

Read all instructions before use.

Keep these instructions.

Before using your new range

- Read all the safety instructions in the front of this *User Guide*.
- Remove all packaging materials from your appliance.
- Confirm that the electrical power to the appliance is turned on.
- Check your installation instructions if you need help.
- Wipe out the inside of your oven cavity with a damp cloth.
- Apply a thin layer of cooking oil to the sides of the oven racks to keep them gliding smoothly.
- Test all surface elements/burners to make sure they are working properly (see [Using the surface elements](#) on page 12).
- Before cooking, set your oven to bake at 350° F (177° C) for 30 minutes (see [Using your oven](#) on page 15). Some noise and odors are normal on the first cooking cycle.
- Remember to complete your product registration!

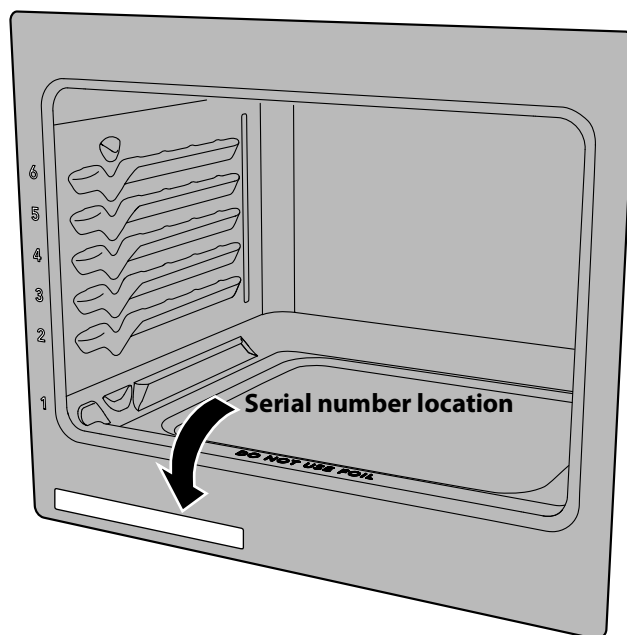

Read all safety instructions before using the product and save these instructions.

This manual contains important safety symbols and instructions. Please pay attention to these symbols and follow all instructions given.

Do not attempt to install or operate your appliance until you have read the safety precautions in this manual. Safety items throughout this manual are labeled with a WARNING or CAUTION statement based on the risk type.

Warnings and important instructions appearing in this guide are not meant to cover all possible conditions and situations that may occur. Common sense, caution, and care must be exercised with installing, maintaining, or operating your appliance.



DEFINITIONS

This is the safety alert symbol. It is used to alert of potential personal injury hazards. Obey all safety messages that follow this symbol to avoid possible injury or death.



WARNING

Indicates a potentially hazardous situation which, if not avoided, may result in death or serious injury.



CAUTION

Indicates a potentially hazardous situation which, if not avoided, may result in minor or moderate injury.

IMPORTANT

Indicates installation, operation, or maintenance information which is important but not hazard-related.

NOTE

Indicates a short, informal reference – something written down to assist the memory or for future reference.



WARNING



Tip Over Hazard

- A child or adult can tip the range and be killed.
- Verify the anti-tip device has been installed to the wall or floor.
- Ensure the anti-tip device is re-engaged to floor or wall when the range is moved.
- Do not operate the range without the anti-tip device in place and engaged.
- Failure to follow these instructions can result in death or serious burns to children or adults.

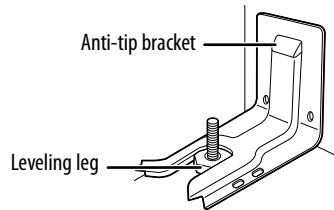

To check if the anti-tip bracket is installed properly, use both arms to grasp the rear edge of the range back. Carefully attempt to tilt range forward. When properly installed, the range should not tilt forward.

Refer to the anti-tip bracket installation instructions supplied with your range for proper installation.

IMPORTANT INSTRUCTIONS FOR UNPACKING AND INSTALLATION

IMPORTANT

Read and follow the below instructions and precautions for unpacking, installing, and servicing your appliance.

Remove all tape and packaging before using the appliance. Destroy the carton and plastic bags after unpacking the appliance. Never allow children to play with packaging material. Do not remove the wiring label and other literature attached to the appliance. Do not remove model/serial number plate.

Cold temperatures can damage the electronic control. When using this appliance for the first time, or when the appliance has not been used for an extended period of time, be sure the appliance has been in temperatures above 32° F (0° C) for at least three hours before turning on the power to the appliance.

All materials used in construction of cabinets, enclosures, and supports surrounding the product must have a temperature rating above 200° F (94° C).

Never modify or alter the construction of the appliance by removing the leveling legs, panels, wire covers, anti-tip brackets/screws, or any other part of the appliance.

Be sure to have an appropriate foam-type fire extinguisher available, visible, and easily accessible located near the appliance.

GROUNDING INSTRUCTIONS



WARNING

- Avoid fire hazard or electrical shock. Failure to follow this warning may cause serious injury, fire, or death.
- Avoid fire hazard or electrical shock. Do not use an adapter plug, use an extension cord, or remove grounding prong from the power cord. Failure to follow this warning may cause serious injury, fire, or death.

Proper Installation - Be sure your appliance is properly installed and grounded by a qualified technician. In the United States, install in accordance with the National Electrical Code NFPA No. 70 latest edition, and local electrical code requirements. In Canada, install in accordance with CAN/CGA B149.1 and CAN/CGA B149.2 and CSA Standard C22.1, Canadian Electrical code, Part 1-latest editions and local electrical code requirements. Install only per installation instructions provided in the literature package for this appliance.

For personal safety, this appliance must be properly grounded. For maximum safety, the power cord must be securely connected to an electrical outlet or junction box that is the correct voltage, is correctly polarized and properly grounded, and protected by a circuit breaker in accordance with local codes.

It is the personal responsibility of the consumer to have the appropriate outlet or junction box with the correct, properly grounded wall receptacle installed by a qualified electrician. It is the responsibility and obligation of the consumer to contact a qualified installer to assure that the electrical installation is adequate and is in conformance with all local codes and ordinances.

See the installation instructions packaged with this appliance for complete installation and grounding instructions.

IMPORTANT INSTRUCTIONS FOR USING THE APPLIANCE

 WARNING
<ul style="list-style-type: none"> • Storage In or On Appliance—Flammable materials should not be stored in an oven or microwave, near surface burners or elements, or in the storage or warmer drawer (if equipped). This includes paper, plastic, and cloth items, such as cookbooks, plastic ware, and towels, as well as flammable liquids. Do not store explosives, such as aerosol cans, on or near the appliance. • Do not leave children alone - Children should not be left alone or unattended in the area where appliance is in use. They should never be allowed to sit or stand on any part of the appliance, including the storage drawer. • Do not store items of interest to children in the cabinets above the appliance or on the backguards of ranges. Children climbing on or near the appliance to reach items could be seriously injured. • Do not allow children to climb or play around the appliance. The weight of a child on an open oven door may cause the appliance to tip, resulting in serious burns or other injury. An open drawer when hot may cause burns. • Stepping, leaning, or sitting on the door or drawers of this appliance can result in serious injuries and also cause damage to the appliance. • Never cover any slots, holes, or passages in the oven bottom or cover an entire rack with materials such as aluminum foil. Aluminum foil linings may also trap heat, causing a fire hazard. • Do not use oven or warmer drawer (if equipped) for storage. • Never use your appliance as a space heater to heat or warm the room. Doing so may result in overheating of the appliance.

IMPORTANT INSTRUCTIONS FOR USING YOUR RADIANT COOKTOP

 CAUTION
<ul style="list-style-type: none"> • When heating fat or grease, watch it closely. Grease may catch fire if it becomes too hot. • Do not use water or flour on grease fires. Smother the fire or flame, or use dry chemical or foam-type extinguisher. Cover the fire with a pan lid or use baking soda. • Use dry potholders. Moist or damp potholders on hot surfaces may result in burns from steam. Do not let potholders touch hot cooking areas. Do not use towels or other bulky cloths. • Do not heat unopened food containers. Build-up of pressure may cause container to burst and result in injury. • Wear proper apparel - Loose-fitting or hanging garments should never be worn while using the appliance. Do not let clothing or other flammable materials contact hot surfaces. • Do not touch surface burners or elements, areas near these burners or elements, interior surfaces of your oven, or the warmer drawer (if equipped). Surface burners and elements may be hot even though they appear cool. • Areas near surface burners and elements may become hot enough to cause burns. During and after use, do not touch, or let clothing or other flammable materials touch these areas until they are cool. These areas may include the cooktop, surfaces facing the cooktop, oven vent areas, oven door, and oven window. • Do not attempt to operate the appliance during a power failure. If the power fails, always turn off the appliance. If the appliance is not turned off and the power resumes, electric surface elements may resume operation when power is restored. Once the power resumes, reset the clock and the oven function.

Know which knob or key controls each surface heating area. Place cookware with food on the cooking area before turning it on. Turn the cooking area off before removing the cookware.

Cookware handles should be turned inward and not extend over adjacent surface elements — To reduce the risk of burns, ignition of flammable materials, and spillage due to unintentional contact with the utensil, the handle of the cookware should be positioned so that it is turned inward, and does not extend over other cooking areas.

Use proper pan size - This appliance is equipped with one or more surface units of different sizes. Select cookware with flat bottoms that match the surface unit size. Using the proper cookware on the cooking area will improve efficiency.

Glazed cooking utensils - Only certain types of glass, glass/ceramic, ceramic, earthenware, or other glazed utensils are suitable for cooktop service without breaking due to the sudden change in temperature. Check the manufacturer's recommendations for cooktop use.

Improper cookware may break due to sudden changes in temperature. Check the cookware manufacturer's recommendations for cooktop use.

Never leave surface elements unattended. Boil-overs may cause smoking and greasy spills that may ignite. A pan that has boiled dry could be damaged and may damage the cooktop.

Do not use a searing grill meant for use with a broiler pan on the cooktop. The searing grill is not designed for use on the cooktop. Doing so may result in a fire.

When you are flaming foods under a ventilating hood, turn on the fan.

IMPORTANT INSTRUCTIONS FOR GLASS AND CERAMIC COOKTOPS

Do not clean or operate a broken cooktop. If the cooktop should break, cleaning solutions and spillovers may penetrate the broken cooktop and create a risk of electric shock. Contact a qualified technician immediately.

Clean cooktop glass with caution. If a wet sponge or cloth is used to wipe spills on a hot cooking area, be careful to avoid a steam burn. Some cleaners can produce harmful fumes if applied to a hot surface.

Avoid scratching the cooktop glass with sharp objects.

IMPORTANT INSTRUCTIONS FOR USING YOUR OVEN

Protective liners - Do not use aluminum foil, after market oven liners, or any other materials or devices to line oven bottom, oven racks, or any other part of the appliance. Only use aluminum as recommended for baking, such as lining cookware or as a cover placed on food. Any other use of protective liners or aluminum foil may result in a risk of electric shock or fire or a short circuit.

Use care when opening oven door, lower oven door, or storage drawer (warming drawer on some models). Stand to the side of the appliance when opening the door of a hot oven. Let hot air or steam escape before you remove or replace food in the oven.

Keep oven vent ducts unobstructed. Touching surfaces in this area when your oven is on may cause severe burns. Do not place plastic or heat-sensitive items on or near the oven vent. These items can melt or ignite.

Placement of oven racks - Always place oven racks in desired location while oven is cool. If rack must be moved while oven is hot, do not let potholder contact hot burner or element in oven. Use potholders and grasp the rack with both hands to reposition. Remove all cookware and utensils before moving the rack. Do not use a broiler pan without its insert. Broiler pans and inserts allow dripping fat to drain away from the high heat of the broiler. Do not cover the broiler insert with aluminum foil; exposed fat and grease could ignite.

Do not cook food on the oven bottom. Always cook in proper cookware and always use the oven racks.

IMPORTANT INSTRUCTIONS FOR CLEANING YOUR APPLIANCE



CAUTION

Before manually cleaning any part of the appliance, be sure all controls are turned off and the appliance is cool. Cleaning a hot appliance can cause burns.

Clean the appliance regularly to keep all parts free of grease that could catch fire. Do not allow grease to accumulate. Greasy deposits in the fan could catch fire.

Always follow the manufacturer's recommended directions for use of kitchen cleaners and aerosols. Be aware that excess residue from cleaners and aerosols may ignite causing damage and injury.

Clean ventilating hoods frequently - Grease should not be allowed to accumulate on hood or filter. Follow the manufacturer's instructions for cleaning vent hoods.

IMPORTANT INSTRUCTIONS FOR CLEANING OVENS



CAUTION

Before cleaning, remove the broiler pan, any food, utensils, and cookware from the oven, storage drawer or warming drawer (if equipped). Remove oven racks unless otherwise instructed.

Do not clean the oven door gasket. The door gasket is essential for a good seal. Care should be taken not to rub, damage, or move the gasket.

SERVICING AND MAINTAINING YOUR APPLIANCE

Do not repair or replace any part of the appliance unless specifically recommended in the manuals. All other servicing should be done only by a qualified technician. This reduces the risk of personal injury and damage to the appliance.

Always contact your dealer, distributor, service agent, or manufacturer about problems or conditions you do not understand.

Ask your dealer to recommend a qualified technician and an authorized repair service. Know how to disconnect the power to the appliance at the circuit breaker or fuse box in case of an emergency.

Remove the oven door from any unused oven if it is to be stored or discarded.

Do not touch a hot oven light bulb with a damp cloth. Doing so could cause the bulb to break. Handle halogen lights (if equipped) with paper towels or soft gloves. Disconnect the appliance or shut off the power to the appliance before removing and replacing the bulb.

! WARNING

California Residents: for cancer and reproductive harm information, visit www.P65Warnings.ca.gov.

USE OF ALUMINUM FOIL, ALUMINUM UTENSILS, OR OVEN LINERS

! WARNING

Never cover any slots, holes, or passages in the oven bottom or cover an entire oven rack with materials such as aluminum foil. Aluminum foil linings may trap heat, causing a fire hazard.

! CAUTION

- Protective liners—Do not use aluminum foil to line the oven bottom. The high heat of the oven can melt these materials to the oven cavity and ruin the oven. These types of materials can also reduce the effectiveness of the air circulation in the oven and produce poor baking results. Only use aluminum foil as recommended in this manual. Improper installation of these liners may result in risk of electric shock or fire.
- Aluminum utensils—The melting point of aluminum is much lower than that of other metals. Care must be taken when aluminum pots or pans are used.
- Oven racks—Do not use aluminum foil to cover the oven racks. Using a liner in the oven restricts the heat and air flow needed to obtain the best possible cooking results for any oven.

Features

- 5.3 cu. ft. (0.15 cu. m) oven with six rack positions helps prepare your meals.
- Dual-size element customizes to fit your pan's size.
- Bake and broil settings change how your oven heats.
- Glass-ceramic surface provides extra workspace and is easy to clean.
- Oven heats from 170° ~ 500° F (77° ~ 260° C) to cook your food.
- Clock and timer functions let you keep track of time.

Dimensions

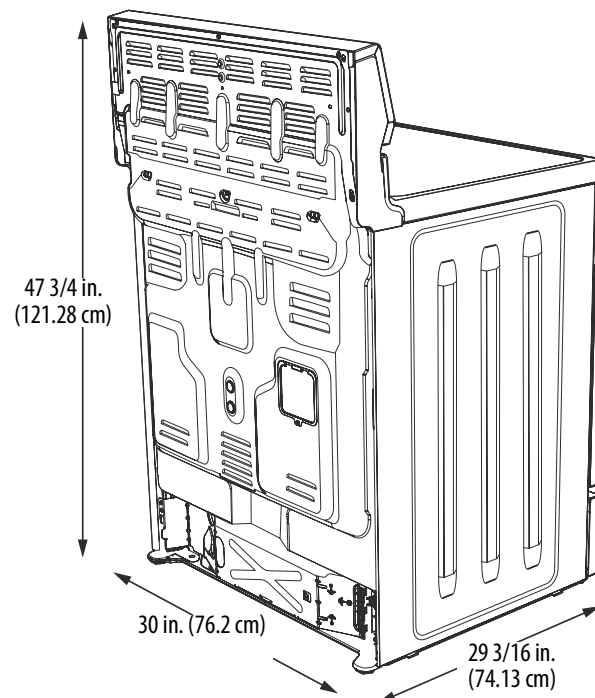

Understanding the cooking surface and surface controls

CAUTION

- Cooktop temperatures increase with the number of surface units that are on. With three or four units turned on, surface temperatures are high. Always use caution when touching the cooktop.
- The type and size of cookware, the number of surface elements in use, and their settings will all affect the amount of heat that will spread to areas beyond the surface elements. The areas surrounding the elements may become hot enough to cause burns.
- Surface elements may appear to have cooled after they have been turned off. The element surface may still be hot, and burns may occur if the element or surrounding area is touched before it has cooled to a safe temperature.
- Do not place flammable items such as plastic salt and pepper shakers, spoon holders, or plastic wrapping on top of the range when it is in use. These items could melt or ignite. Potholders, towels, or wooden spoons could catch fire if placed too close to the surface elements.
- Do not use aluminum foil to line surface drip bowls or reflector pans. Improper installation of these liners may result in risk of electric shock or fire.

IMPORTANT

- The cooktop should not be used as a cutting board or work surface.
- Dropping heavy or hard objects on the cooktop may crack it.
- Placing food directly on the cooktop surface (without a cooking utensil) is not recommended, as difficult cleaning will result, and foods may smoke and cause potential fire hazard.
- Always lift cookware before moving on the ceramic glass cooktop. Any cookware that has a rough or dirty bottom can scratch the ceramic cooktop. Always start with clean cookware.

Using the glass-ceramic cooktop

The ceramic glass cooktop has heating elements below a smooth glass surface. The designs on the ceramic cooktop outline the areas of the surface elements underneath. An indicator light will come on when the surface unit is turned on. The appropriate **HOT** surface indicator light will glow when its corresponding radiant element is turned on and will remain on until the surface has cooled below 150° F (65.5° C). The element temperature rises gradually and evenly. As the temperature rises, the element will glow red. To maintain the selected setting the element will cycle on and off. The heating element retains enough heat to provide a uniform and consistent heat during the off cycle.

Even after the surface units are turned off, the glass cooktop retains enough heat to continue cooking. For efficient cooking, turn the element off several minutes before cooking is complete. This will allow residual heat to complete the cooking process. To avoid overcooking, remove pans from the surface units when the food is cooked. Avoid placing anything on the surface unit until it has cooled completely.

Prior to using your cooktop for the first time, apply a ceramic cooktop cleaning cream (widely available) to the cooktop surface, then clean and buff it with a clean paper towel. This will make cleaning the surface easier after cooking. Cooktop cleaning creams leave a protective finish on the glass to help prevent scratches and abrasions. A slight odor is normal when a new cooktop is used for the first time. It is caused by the heating of new parts and insulating materials and will disappear in a short time.

NOTES

- It is normal for the cooking zones to change color when hot or cooling down. This is temporary and will disappear as the glass cools to room temperature.
- Radiant elements have a limiter that causes the element to cycle on and off, even at the **Hi** setting.
- It is safe to place hot cookware from the oven or surface on the glass cooktop when the surface is cool.
- Be sure to read detailed instructions for cleaning your cooktop in the [Care and cleaning of your range - general cleaning](#) section on page 21 of this *User Guide*.
- Water stains (mineral deposits) are removable using the cleaning cream.
- Use of window cleaner may leave an iridescent film on the cooktop. The cleaning cream will remove this discoloration.
- Don't store heavy items above the cooktop. If they drop onto the cooktop, they can cause damage.
- Do not use the surface as a cutting board.

Every radiant surface unit has a temperature limiter, which protects the glass cooking surface from getting too hot.

The temperature limiter may cycle the units off for a time if:

- The pan boils dry.
- The pan bottom is not flat.
- The pan is off center.
- There is no pan on the unit.

Selecting the proper cookware for the ceramic cooktop

IMPORTANT

- Do not place empty aluminum, glass, or porcelain- enamel coated cookware on the element. The melting point of cookware made with these materials may be reached quickly, especially if left empty. If the cookware melts it will damage the cooktop.
- NEVER place or straddle a cooking utensil over two different surface cooking areas at the same time. Incorrect use may damage the cooktop.

The following information will help you choose cookware which will give good performance on glass cooktops. The size and type of cookware used will determine the heat setting needed for best cooking results. Be sure to follow the recommendations for using proper cookware as shown below, and always follow all the cookware manufacturer's recommendations for use and care of cookware.

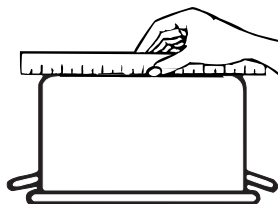

Check pots or pans for flat bottoms by using a straight edge.

RECOMMENDED	NOT RECOMMENDED
<ul style="list-style-type: none"> • Flat bottom pots or pans with straight sides. • Pots or pans with tight fitting lids. • Well balanced pots and pans, where the weight of the handle does not cause it to tilt. • Pot or pan sizes matched to the amount of food to be prepared and the size of the surface element. • Pots or pans made of material that conducts heat well (see below). 	<ul style="list-style-type: none"> • Pots or pans with curved or warped bottoms. • Pots or pans that are larger than the cooking element by more than 1/2 in. (1.2 cm). • Unbalanced pots or pans where a heavy handle tilts it. • Pots or pans much smaller than the cooking element.

Understanding how various factors affect cooking

Use medium- or heavy-weight cookware. Aluminum cookware conducts heat faster than other metals. Cast-iron and coated cast-iron cookware are slow to absorb heat, but generally cook evenly at low to medium heat settings. Steel pans may cook unevenly if not combined with other metals. For best cooking results, pans should be flat on the bottom. Match the size of the saucepan to the size of the surface unit. The pan should not extend over the edge of the surface unit more than 1/2 in. (1.27 cm).

Understanding bakeware

The material used in bakeware manufacture affects how evenly and quickly it transfers heat from the pan to the food and should be considered when cooking.

MATERIAL	ATTRIBUTES	RECOMMENDATION
Shiny metal bakeware	Shiny, aluminum, and non-coated bakeware is the best for even heating. It is suitable for all baked goods.	Recommended cooking temperatures and times are based on shiny metal bakeware.
Dark metal bakeware	Dark bakeware cooks hotter than shiny bakeware.	Reduce the cooking temperature in the oven by 25° F (13-14° C) when using dark bakeware.

MATERIAL	ATTRIBUTES	RECOMMENDATION
Glass bakeware	Glass bakeware cooks hotter than shiny bakeware. Glass is convenient, as the same piece of bakeware can be used for cooking, serving, and storing food.	Reduce the cooking temperature in the oven by 25° F (13-14° C) when using glass bakeware.
Insulated bakeware	Insulated bakeware cooks cooler than shiny bakeware. Insulated bakeware is designed for baking in gas ovens	Increase the cooking temperature in the oven by 25° F (13-14° C) when using insulated bakeware

Cooking conditions

Conditions in your kitchen can affect the performance of your appliance when cooking food.

CONDITION	ATTRIBUTES	RECOMMENDATION
Aging cookware	As pans age and become discolored, cooking times may need to be reduced slightly.	If food is too dark or overcooked, use the minimum cook time in the recipe or packaging. If food is too light or undercooked, use the middle to maximum cook time in the recipe or packaging.
High altitude	Air is drier and air pressure is lower. Water boils at a lower temperature, and liquids evaporate faster. Foods may take longer to bake. Doughs may rise faster.	Adjust cooking temperature, cooking time, or recipes as needed. Increase amount of liquid in baking recipes. Increase cook time on cooktop. Cover dishes to reduce evaporation. Increase bake time or oven temperature. Reduce amount of baking soda or baking powder in recipe. Reduce rising time or punch down dough and allow it to rise twice.

Cooking results

Small adjustments may fix a problem with food not being as done as you like or more done than you like.

RESULT	RECOMMENDATION
Food too light	Use the middle to maximum cook time recommended on packaging or recipe.
Food too dark	Use the minimum cook time recommended on packaging or recipe.

Cookware materials

Stainless steel:

Recommended

Stainless steel is a slow heat conductor with uneven cooking results, but it's durable, easy to clean, and resists staining.

Aluminum:

Heavy weight recommended

Good conductivity. Aluminum residues sometimes appear as scratches on the cooktop, but can be removed if cleaned immediately. Because of its low melting point, thin-weight aluminum should not be used.

Copper bottom:

Recommended

Copper may leave residues which can appear as scratches. The residues can be removed, as long as the cooktop is cleaned immediately. However, do not let these pots boil dry. Overheated metal can bond to glass cooktops. An overheated copper bottom pot will leave a residue that will permanently stain the cooktop if not removed immediately.

Cast Iron:

A slow heat conductor, but retains heat very well and cooks evenly once the cooking temperature is reached.

Porcelain enamel-covered cast iron:

Recommended

As long as the cookware is covered completely with porcelain enamel, this cookware is recommended. Caution is recommended for cast-iron cookware that is not completely covered with smooth porcelain enamel, as it may scratch the glass-ceramic cooktop.

Glass-ceramic:

Usable, but not recommended

Poor performance. May scratch the surface.

Stoneware:

Usable, but not recommended

Poor performance. May scratch the surface.

Using the surface elements

NOTES

- The size and type of cookware used and the amount and type of food being cooked will determine the optimum setting for best cooking results.
- The **ELEMENT ON** indicator lights turn on when one or more surface elements are turned on. These indicator lights should be checked when finished cooking to be sure all control knobs are turned **OFF**. The **HOT SURFACE** indicator light remains on after the control knob is turned to the **OFF** position and will stay on until the heating surface area has cooled.

Understanding the types of cooktop elements

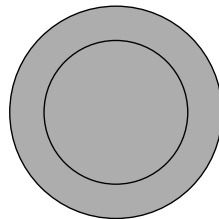

Double element

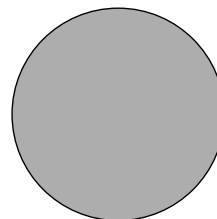

Single element

The circles on the ceramic glass cooktop outline the size and type of element underneath.

- A single element has one circle.
- A dual element has two circles. The dual element can be set to use only the smaller inner element, or set to use both the inner and outer elements for a larger cooking surface. Dual elements allow more flexibility with the size of cookware.

Setting a single element

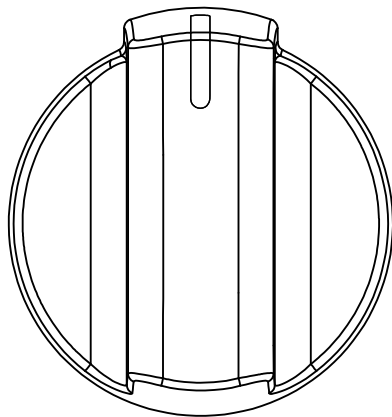

Front view

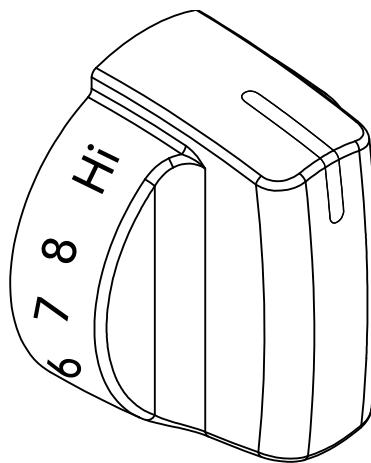

Oblique view

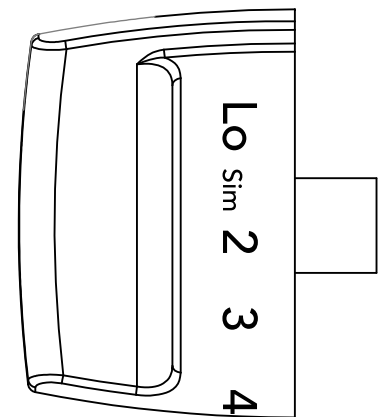

Side view

To operate single elements:

- 1 Place the cookware on the surface element.
- 2 Push in and turn the control knob for the burner you have selected in either direction to the desired setting.
- 3 When cooking is complete, turn the element **OFF** before removing the cookware.

Setting dual surface elements

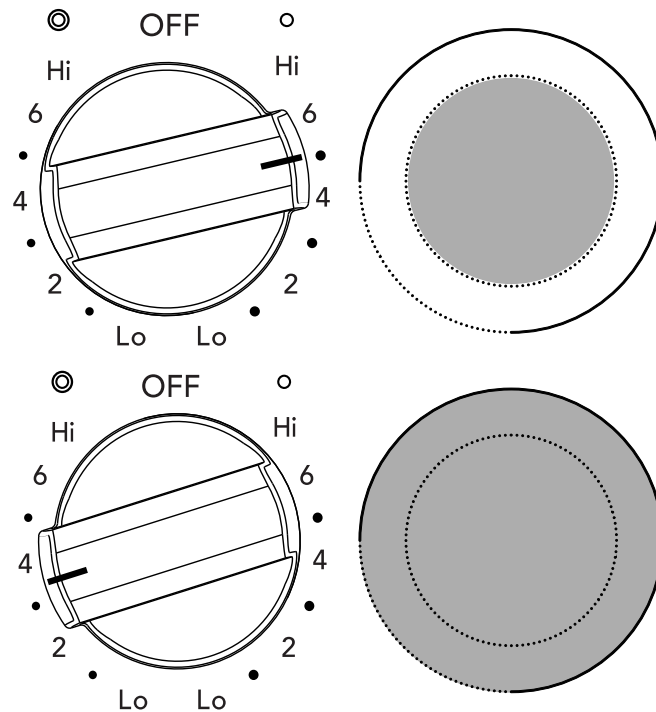

Surface map on the front panel is provided to help you choose which element to set.

To operate a dual element:

- 1 Place correctly sized cookware on the surface element.
- 2 Push in and turn the surface control knob to the left (counterclockwise) to the second setting range to begin heating both the inner and outer elements. If only the inner element is needed for smaller cookware, push in and turn the knob to the right (clockwise) only into the first setting range.
- 3 When cooking is complete, turn the knob to **OFF** before removing the cookware.

Using either the single or dual elements

Start most cooking operations on a higher setting, then turn to a lower setting to finish cooking. The surface control knobs do not have to be set exactly. Use the suggested settings provided as a guide and adjust the knob as needed.

A glowing red surface heating area extending beyond the bottom edge of the cookware indicates the cookware is too small for the surface heating area.

You can switch from either single or dual element setting at any time during cooking.

Suggested settings

The suggested settings, appropriate for both single- and dual-elements, found below are based on cooking with medium-weight aluminum pans with lids. Settings may vary when using other types of cookware.

SETTING	TYPE OF COOKING
High (Hi)	To start most foods, bring water to a boil, pan broiling
Medium High (7 - 8)	To continue a rapid boil, fry, deep fat fry
Medium (5 - 6)	To maintain a slow boil, thicken sauces and gravies, or steam vegetables
Medium Low (2 - 4)	To keep foods cooking, poach, and stew
Low/Low (Lo)	Low temperature cooking To keep food warm or melt butter, cheese, and so on

Indicator lights

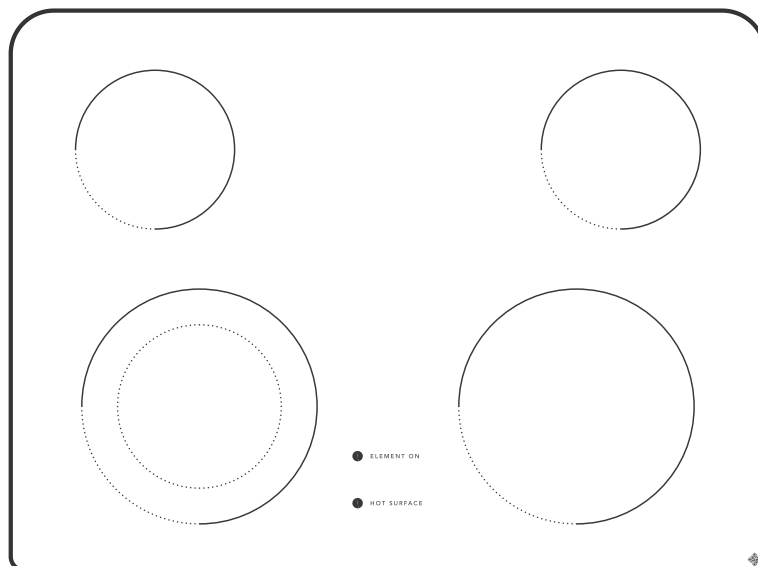

The **ELEMENT ON** indicator light turns on when one or more elements are turned on. Check this light when cooking is finished, to be sure all surface elements are turned off.

The **HOT SURFACE** indicator lights when a burner is hot enough to cause burns, and remains on after a burner is turned off until the surface has cooled to a safe temperature.

Using your oven

⚠ WARNING

- Do not use aluminum foil or any other material to line the oven bottom, walls, racks or any other part of the interior of your oven. Doing so will alter the heat distribution within your oven, produce poor baking results, and possibly cause permanent damage to your oven interior. Improper installation of these liners may result in risk of electric shock or fire.
- In case of an oven fire, close the oven door and turn your oven off. If the fire continues, use a fire extinguisher. Do not put water or flour on the fire. Flour may be explosive.
- When cooking, the oven interior, oven exterior, oven racks, and cooktop will become very hot, which may cause burns. Always use pot holders or oven mitts when using your oven.

⚠ CAUTION

To prevent possible damage to your oven, do not attempt to close the oven door until all the oven racks are fully pushed back inside the oven cavity.

Using the oven controls

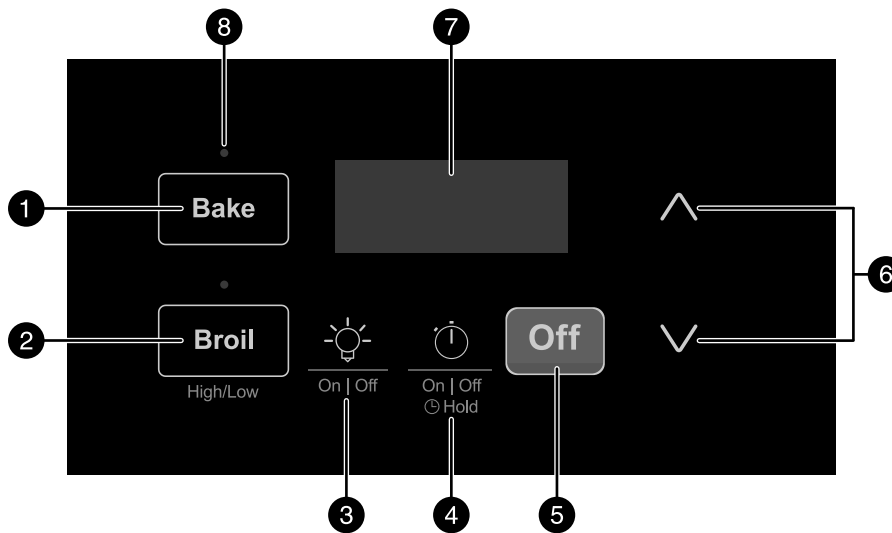



#	ITEM	FUNCTION
1	Bake button	Touch this button to select the bake function.
2	Broil (High/Low) button	Touch this button to select the broil function. Press the \wedge button for High and the \vee button for Low.
3	💡 (light) button	Touch this button to turn the oven light on or off.
4	🕒 (timer/clock) button	To set the timer, touch this button, then touch the \wedge / \vee buttons to adjust the timer. The timer will automatically start once the time is selected. To set the clock, touch and hold this button until the time flashes, then enter the correct time with the \wedge / \vee buttons.
5	OFF button	Touch this button to cancel ALL oven operations except the clock and timer.
6	\wedge / \vee buttons	Press these buttons to increase or decrease the time or temperature by small amounts. Press and hold these buttons to quickly increase or decrease the time or temperature.
7	Display	Shows the time of day, oven temperature, whether your oven is in the bake or broil mode and the times set for the timer or automatic oven operations. The display will show the set temperature while preheating. When your oven reaches the selected temperature, the oven control will beep and the display will show the oven temperature. If F or E and a number or letter flash in the display and the oven control beeps, this indicates a function error code. If your oven was set for a timed oven operation and a power outage occurred, the clock and all programmed functions must be reset. The time of day will flash in the display when there has been a power outage. Reset the clock.
8	Baking indicator light	The light blinks until a temperature is selected and stays on while the oven is preheating.

Minimum and maximum settings



FUNCTION	MODE	MIN TIME/TEMP	MAX TIME/TEMP
Bake		170° F (77° C)	500° F (260° C)
Broil		Lo	Hi
Timer	12 Hr.	0:01 Min.	11:59 Hr./Min.
	24 Hr.	0:01 Min.	11:59 Hr./Min.
Clock Time	12 Hr.	1:00 Hr./Min.	12:59 Hr./Min.

Setting the clock

NOTES



- The clock setting cannot be changed when the oven is in the cooking process.
- If the time is flashing on the display, you have experienced a power outage and the clock must be reset.
- To reset the clock, touch and hold the  (timer/clock) button until the time flashes, then enter the correct time by touching the  or  buttons, then touch any button to accept the change.

When the range is plugged in or if the power is interrupted, the display flashes **12:00**.

- 1 Press and hold the  (timer/clock) button for three seconds.
- 2 Within five seconds, press and hold  or  until the correct time of day appears in the display.
- 3 Press any button to accept the change and set the time.

Changing the displayed temperature (°F to °C)

Your oven comes preset at the factory to operate in Fahrenheit (°F). To change the temperature from Fahrenheit (°F) to Celsius (°C) or from Celsius (°C) to Fahrenheit (°F) do the following.

- 1 Press the **Broil** button (about six seconds) until **F** or **C** appears in the display.
- 2 Press  or  to change °F to °C or °C to °F.
- 3 The display returns to the set time.



Temperature conversions

°F	170	200	250	275	300	325	350	375	400	425	450	475	500
°C	75	95	120	135	150	160	175	190	205	220	230	245	260

Setting the timer



NOTES

- The timer will not start or stop the cooking process.
- The timer can be used alone or while using any of the other oven features. If another feature is active when the timer is active, the timer will be shown on the display. To view information about other active features, press the button for that feature.
- If  is initially pressed the timer will automatically advance to 11 hours and 59 minutes.

- 1 Press the  (timer/clock) button.
- 2 Press  to increase time in one-minute increments. Press and hold  to quickly increase time. The timer can be set for any amount of time from 1 minute to 11 hours and 59 minutes. The timer will automatically start when the time is selected.

When the set time expires, the timer will long beep (3 seconds) and will continue to long beep every minute until the  (timer/clock) button is pressed.

Changing the timer while it is in use:

- While the timer is active and displayed, press and hold  or  to increase or decrease the time remaining.

Canceling the timer before the set time has expired:

- Press the  (timer/clock) button once.

Using the oven racks**CAUTION**

Use caution when pulling an oven rack out from the lowest position. We recommend that you pull the rack out several inches and then, using two pot holders, pull the rack out by holding it by the sides. The rack is low and you could be burned if you place your hand in the middle of the rack and pull all the way out. Also, be very careful not to burn your hand on the door when using the rack in the lowest position.

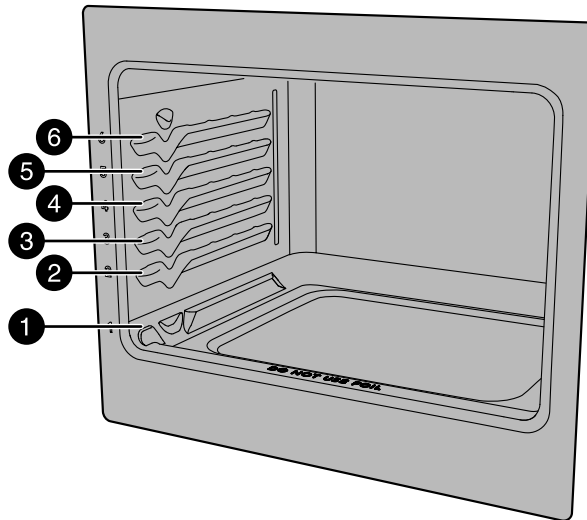

- Always arrange oven racks when your oven is cool.
- The oven racks have stops, so that when placed correctly on the supports, they will stop before coming completely out, and will not tilt.
- When placing and removing cookware, pull the rack out until it stops.
- To remove a rack, pull it toward you, tilt the front end up and pull it out.
- To replace a rack, place the end of the rack (stop-locks) on the support, tilt up the front, then push the rack in.
- Racks can be stored in the bottom drawer of your range.

Baking in your oven**NOTES**

- Baking in your oven cooks with heat that rises from the bottom of your oven. Heat and air circulate naturally in your oven.
- Your oven can be programmed to bake at any temperature from 170° to 500° F (77° to 260° C). The factory preset baking temperature is 350° F (177° C).

Baking Tips

- Fully preheat your oven before baking items like cookies, cakes, biscuits, and breads.
- When using any single rack, use rack position 4.
- For best results when baking cakes using two oven racks, place racks in positions 3 and 5.
- When baking using two oven racks, position cookware to allow at least 2 in. (5 cm) of space for proper air circulation.

- When baking a two-layer cake, position both layers on a single rack. For a four-layer cake (or 2, two-layer cakes) position two layers on one rack in the front, and two layers on the other rack in the back.

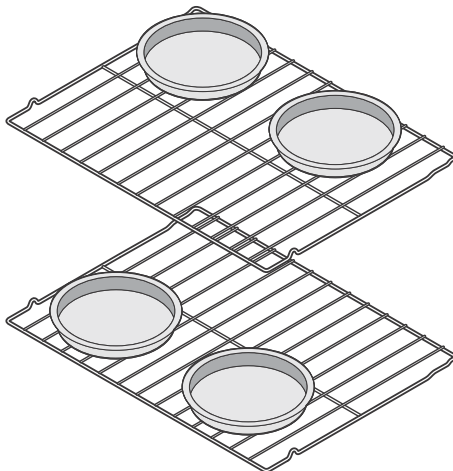

Setting your oven to bake

- 1 Make sure that your clock is set up before setting your oven to bake. See [Setting the clock](#) on page 16.
- 2 Within five seconds, press **▲** or **▼**. The display shows 350° F (177° C). The temperature can then be adjusted upwards or downwards in 5° F (1° C) increments.
- 3 Press the **Bake** button. — — — appears on the display. The indicator light will blink until a temperature is selected.
- 4 When a button is released, your oven begins heating to the selected temperature. When your oven reaches the set temperature, the bake indicator light stops flashing and one long beep will sound.
- 5 To cancel the baking process, press **OFF**.

Changing the oven temperature during the baking process

- 1 Press the **Bake** button.
- 2 Press **▲** or **▼** to increase or decrease to a different temperature.
If this change is initiated during the preheat process, the oven indicator light turns on and off. This is normal and indicates that your oven is cycling on and off to maintain the selected baking temperature.
- 3 To cancel the baking process, press **OFF**.

Adjusting the oven temperature

NOTES

- Oven temperature adjustments made will not affect the broil temperatures.
- You can cancel the oven temperature adjustment at any time by pressing the **OFF** button (before your oven beeps).

Your oven has been tested and calibrated at the factory to ensure an accurate baking temperature. Initially, we suggest that you follow your recipes' suggested times and temperatures. If you think your oven is cooking too hot or too cool for your recipe times, you can adjust the control so your oven cooks hotter or cooler than the temperature displayed.

Do not use oven thermometers such as those found in grocery stores to check the temperature settings inside your oven. These oven thermometers may vary as much as 20 to 40 degrees from actual temperatures.

To adjust the oven temperature:

- 1 Press the **Bake** button. — — — appears on the display.
- 2 Press and hold **▲** to set the oven temperature to 500° F (260° C).
- 3 Within three seconds, press and hold the **Bake** button until numeric digit(s) appear. Release the button. The display now shows the amount of degrees of offset between the original factory temperature setting and the current temperature setting. If the oven control has the original factory calibration, the display will show **00**.
- 4 Press and hold **▲** or **▼** to adjust the temperature higher or lower (the temperature can be adjusted up or down up to 35° F (19° C), in 5° F (1° C) increments until the desired amount of offset appears in the display.

NOTE

When you adjust the temperature lower, a minus sign (-) appears before the number to indicate that your oven will be cooler by the displayed amount of degrees.

- 5 When you have finished making the desired adjustment, press **OFF** to return to the time-of-day display.

Broiling in your oven

WARNING

The broiler pan and the insert (not included) permit grease to drain from the food being cooked. This keeps the grease away from the high heat of the broiler. Do not use the pan without the insert. Do not cover the insert with aluminum foil or the exposed grease could ignite.

NOTES



- Broiling is direct heat cooking and will produce some smoke. If smoke is excessive, place food further away from the heating element. Watch food to prevent burning.
- When broiling, always remember to arrange the oven racks while oven is still cool. Position the rack as suggested in the table below.

Broiling recommendations

FOOD TYPE	RACK POSITION	TEMP	COOK TIME IN MINUTES		DONENESS
			1ST SIDE	2ND SIDE	
Steak (approx. 1 in. thick)	6th	HI	5 min. 6 min.	4 min. 5 min.	Rare Medium
Pork chops (3/4 in. thick)	5th		8 min.	6 min.	Well
Chicken (bone in)	4th		20 min.	10 min.	
Chicken (boneless)	4th and 5th		8 min.	6 min.	
Fish	4th and 5th		add as directed	add as directed	
Shrimp	4th and 5th		add as directed	add as directed	
Hamburger (1 in. thick)	4th and 5th		9 min.	7 min.	

The U.S.D.A. states that "Rare fresh beef is popular, but you should know that cooking it to only 140° F (60° C) means some food poisoning organisms may survive." (Source: Safe Food Book, Your Kitchen Guide, USDA Rev. June 1985.) The lowest temperature recommended by the USDA is 145° F (63° C) for medium rare fresh beef. For well done 170° F (77° C). All cook times shown are after your oven is preheated for two minutes.

Setting your oven to broil

- 1 Arrange the oven rack while your oven is still cool.
- 2 Press the **Broil** button. — — appears on the display.
- 3 Press  for **Hi** broil or  for **Lo** broil. Most foods can be successfully broiled at the **Hi** broil setting. To avoid excessive browning or drying, select the **Lo** broil setting. We suggest that you preheat your oven for two to five minutes prior to starting to broil your food.
- 4 If you are using a broil pan and insert (not included), place the insert on top of the broil pan and put the food on the insert.

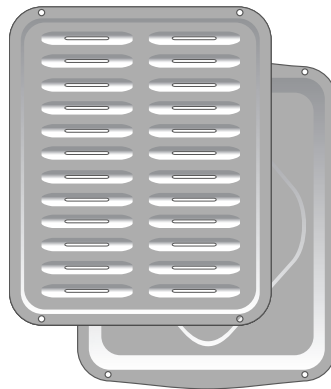

- 5 Place the broiler pan and insert on the oven rack.
- 6 Broil on one side until food is browned, then turn the food to broil the second side.
- 7 When broiling is completed and your food is cooked, press **OFF**.

Cooking tips

Surface cooking tips

Wok cooking

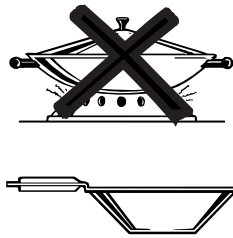

We recommend that you use only a flat-bottomed wok. They are available at your local retail store.

Do not use woks that have support rings. Use of these types of woks, with or without the ring in place, can be dangerous. Placing the ring over the surface unit will cause a buildup of heat that will damage the porcelain cooktop. Do not try to use such woks without the ring. You could be seriously burned if the wok tips over.

Home canning tips

Be sure to read and observe all the following points when home canning with your appliance. Check with the USDA (United States Department of Agriculture) Web site and be sure to read all the information they have available as well as follow their recommendations for home canning procedures.

- Use recipes and procedures from reputable sources. These are available from manufacturers such as Ball® and Kerr® and the Department of Agriculture Extension Service.
- Use only a completely flat bottom canner with no ridges that radiate from the bottom center when home canning. Heat is spread more evenly when the bottom surface is flat. Use a straight-edge to check the bottom of the canner.
- Make sure the canner is flat on the bottom and that the diameter of the canner does not exceed 1 in. (2.5 cm) beyond the surface element markings or burner.
- It is recommended to use smaller diameter canners on electric coil and glass-ceramic cooktops and to center canners on the burner grates.
- Start with hot tap water to bring water to boil more quickly.
- Use the highest heat setting when first bringing the water to a boil. Once boiling is achieved, reduce heat to lowest possible setting to maintain that boil.
- Use tested recipes and follow instructions carefully. Check with your local Cooperative Agricultural Extension Service or a manufacturer of glass jars for the latest canning information.
- It is best to can small amounts and light loads. Do not leave water bath or pressure canners on high heat for an extended amount of time.

Oven cooking tips

Use these additional tips to get the best results from your appliance.

TYPE OF COOKING	VARIABLE	RECOMMENDATION
Baking	Rack placement	Follow the instructions in Using the oven controls on page 15. When using only one rack, place the rack so the food is in the center of your oven.
	Preheat	Fully preheat your oven before baking items like cookies, cakes, biscuits, and breads. Insert food immediately after the beep.
	Checking food	Use the window and oven light when checking food. Opening the door may reduce baking performance.
	Food placement	Allow at least 2 in. (5 cm) of space between bakeware for proper air circulation.
Broiling/Roasting	Broiling pan	For best results when broiling, use a broil pan with a broil pan insert (available locally) designed to drain the fat from the food, help avoid spatter, and reduce smoking. The broiler pan will catch grease spills, and the insert helps prevent grease splatters.

Using butter and margarine

Most recipes for baking have been developed using high fat products such as butter or margarine (80% fat). If you decrease the fat, the recipe may not give the same results as with a higher fat product.

Recipe failure can result if cakes, pies, pastries, cookies, or candies are made with low-fat spreads. The lower the fat content of a spread product, the more noticeable these differences become.

Federal standards require products labeled "margarine" to contain at least 80% fat by weight. Low-fat spreads, on the other hand, contain less fat and more water. The high moisture content of these spreads affects the texture and flavor of baked goods. For best results with your old favorite recipes, use margarine, butter, or stick spreads containing at least 70% vegetable oil.

Care and cleaning of your range - general cleaning



CAUTION

- Do not use steel wool pads. They will scratch the surface of your range.
- Do not use bleach, gasoline, or similar harsh cleaning products on your range.
- Be sure that all controls are turned off and all surfaces are cool before cleaning any part of your range.
- If ammonia or appliance cleaners are used to clean your range, they must be removed and the appliance must be thoroughly rinsed before operating. Follow the manufacturer's instructions and provide adequate ventilation.

NOTE

Remove spills and messes as soon as possible after they occur so that they don't dry on your range. Regular cleaning will reduce the difficulty of major cleaning later.

Refer to the table below for more information about cleaning specific parts of your range.

SURFACE OR AREA TO BE CLEANED	RECOMMENDATION
Aluminum and vinyl	Use a soft cloth with water and a mild dish detergent to clean these surfaces. Rinse surfaces with a sponge and clean water, then dry and polish them with a soft, clean cloth.
Painted surfaces (including plastic control knobs, body parts, or decorative trims)	Use a soft cloth with water and a mild dish detergent, or a 50/50 solution of vinegar and water, to clean these surfaces. Rinse surfaces with a sponge and clean water, then dry and polish them with a soft, clean cloth. Glass cleaners may be used, but do not apply directly to surface.
Control panel	Use a soft cloth with water and a mild dish detergent, or a 50/50 solution of vinegar and water, to clean this surface. Please be aware of the following: <ul style="list-style-type: none"> • Do not spray liquids directly on the oven control and display area. • Using large amounts of water may cause damage to the appliance. • Do not use other liquid cleaners, abrasive cleaners, scouring pads, or paper towels as they can damage the surface.
Control knobs	Use a soft cloth with water and a mild dish detergent, or a 50/50 solution of vinegar and water, to clean the knobs. Control knobs can be removed by turning the knobs to the OFF position, grasping them firmly, and pulling them off the shaft. To replace knobs after cleaning, line up the OFF markings and push the knobs back into place.
Stainless steel	Use a soft cloth with water and a mild dish detergent, or a 50/50 solution of vinegar and water, to clean this surface. Rinse surfaces with a sponge and clean water, then dry and polish them with a soft, clean cloth. Do not use cleaners containing abrasives, chlorides, chlorine, or ammonia.
Fingerprint proof Stainless Steel Black Stainless Steel	Use a soft cloth with water and a mild dish detergent, or a 50/50 solution of vinegar and water, to clean this surface. Rinse surfaces with a sponge and clean water, then dry and polish them with a soft, clean cloth. Do not use appliance cleaner, stainless steel cleaner, or cleaners containing abrasives, chlorides, chlorine, or ammonia. These cleaners may damage the finish.
Porcelain-enameled broiler pan and insert Porcelain door liner Porcelain body parts	Rinse with clean water and a damp cloth. Scrub gently with a soapy, non-abrasive scouring pad to remove most spots. Rinse with a 50/50 solution of clean water and ammonia. If necessary, cover difficult spots with an ammonia-soaked paper towel for 30 to 40 minutes. Rinse and wipe dry with a clean cloth. Remove all cleaners or future heating could damage the porcelain. Do not allow food spills with a high sugar or acid content (milk, tomatoes, sauerkraut, fruit juices, or pie filling) to remain on porcelain surfaces. These spills may cause a dull spot even after cleaning.

SURFACE OR AREA TO BE CLEANED	RECOMMENDATION
Manual cleaning the oven interior	The oven interior is porcelain coated and safe to clean using oven cleaners. Always follow the manufacturer's instructions for cleaners. After cleaning, remove any oven cleaner or the porcelain may become damaged during future heating. Do not spray oven cleaner on any electrical controls or switches. Do not spray or allow oven cleaner to build up on the oven temperature sensing probe. Do not spray cleaner on oven door trim, door gasket, plastic drawer glides, handles, or any exterior surfaces of the appliance.
Oven door	Use a soft cloth with water and a mild dish detergent, or a 50/50 solution of vinegar and water, to clean the top, sides, and front of the oven door. Rinse well. Glass cleaner may be used on the outside glass of the door. Ceramic smooth top cleaner or polish may be used on the interior glass. Do not immerse the door in water. Do not spray or allow water or cleaners to enter the door vents. Do not use oven cleaners, cleaning powders, or any harsh abrasive cleaning materials on the outside of the oven door. Do not clean the oven door gasket. The oven door gasket is made of a woven material which is essential for a good seal. Do not rub, damage, or remove this gasket.
Ceramic cooktop	See below.

Cleaning and maintaining the cooktop



WARNING

Do not use cooktop cleaner on a hot cooktop. The fumes could be hazardous to your health, and the chemicals could cause damage to the ceramic-glass surface.



CAUTION

Before cleaning your cooktop, make sure that the controls are turned to **OFF** and that the cooktop is cool to the touch. The glass surface could still be hot from cooking, or be hot from contact with hot cookware, and you could be burned if you touch the glass surface before it has cooled.

IMPORTANT

- Be careful using any cookware with a rough bottom, or with dirt or dirt buildup on the bottom, which can mark or scratch the cooktop surface. Use only smooth, clean cookware.
- Using an abrasive cleaning pad on the ceramic cooktop could cause damage to the surface. Only use cleaning products that are designed for use with ceramic cooktops.
- Do not slide anything metal or glass across the cooktop.
- Do not use your cooktop as a cutting board or work surface.
- Do not cook foods directly on the cooktop surface without a pan.
- Do not drop heavy or hard objects on the ceramic glass cooktop as they may cause it to crack.

Consistent and proper cleaning is essential to maintaining your ceramic glass cooktop.

Sliding pots or pans on the cooktop may cause metal markings on the cooktop surface. These marks should be removed immediately after the cooktop has cooled using cooktop cleaning cream. Metal marks can become permanent if not removed prior to continued use.

For light to moderate soil:

Apply a few drops of cooktop cleaning cream directly to the cooktop. Use a clean paper towel to clean the entire cooktop surface. Make sure the cooktop is cleaned thoroughly, leaving no residue. Do not use the towel you use to clean the cooktop for any other purpose.

For heavy, burned on soil:

Apply a few drops of cooktop cleaning cream directly to the soiled area. Rub the soiled area using a non-abrasive cleaning pad. Apply pressure if necessary. If cooked-on food remains, carefully scrape with a razor blade (in a blade holder), at a 30 degree angle to the surface. Finish cleaning by again applying cooktop cleaning cream.

Cleaning your oven



WARNING

- Before manually cleaning any part of your oven, be sure all controls are turned off and your oven is cool. Burns could result if you try to clean your oven while it is hot.
- Ammonia must be rinsed before operating your oven. Adequate ventilation should be provided. Do not mix ammonia with other cleaners.

The oven interior is porcelain on steel, which is safe to clean using oven cleaners.

Prior to cleaning your oven, remove all racks and accessories.

Wear rubber gloves when cleaning the appliance manually.

Do not let spills of food with a high sugar or acid content (such as milk, tomatoes, fruit juices, sauerkraut, or pie filling) to remain on the surface, as they may cause a dull spot, even after cleaning. Remove baked on food using hot, soapy water. Remove spills and heavy soiling as soon as possible. Regular cleaning will help reduce the time and effort required for major cleaning later on.

Removing heavy soil

- 1 Place a dish of ammonia in your oven overnight, or for several hours, with the oven door closed. Remove the ammonia, then clean the softened dirt spots using hot, soapy water. Rinse well with water and a clean cloth.
- 2 If baked on food remains, use a nonabrasive scouring pad or a nonabrasive cleaner. If necessary, use an oven cleaner, following the manufacturer's instructions.
- 3 Clean any baked on food from the oven door frame, the door liner outside the oven door gasket, and the small area at the front center of the oven bottom. Clean with hot, soapy water. Rinse the area well using clean water and a cloth.

Removing and replacing the oven door

CAUTION

- The door is very heavy. Be careful when removing and lifting the door or you could be injured. Do not lift door by the handle.
- If improperly removed, oven door hinges may suddenly open and can cause personal injury to appendages near the hinge. Follow instructions below to avoid a risk of injury when removing and re-installing the oven door.

IMPORTANT

- Your oven door can be damaged if not handled carefully. For safe, temporary storage, lay the door flat with the inside of the door facing down.
- Your oven door contains glass that is breakable. Do not hit the glass with pots, pans, or any other object. Scratching, hitting, jarring, or stressing the glass may weaken its structure, causing an increased risk of breakage.
- Do not close the oven door until all of the oven racks are fully in place or damage could result.

Removing the door

- 1 Fully open the oven door.
- 2 With thumb and forefinger, pull up the hinge lock on each hinge to the unlocked position until it stops.

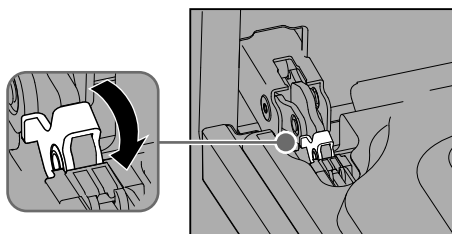

- 3 Firmly grasp both sides of the door near the top.
- 4 Close the door until it makes contact with the unlocked hinges.

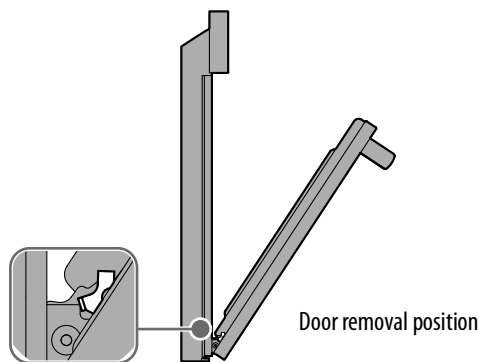

- 5 Pull the bottom of the door toward you while rotating the top of the door toward the appliance to completely disengage the hinge levers.

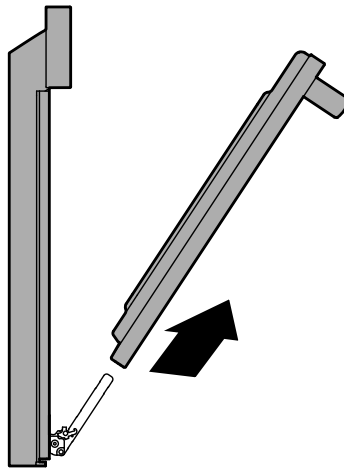

Replacing the door

- 1 Firmly grasp both sides of the door near the top.
- 2 With the door at the same angle as the removal position, insert the hinge levers into the hinges on the oven frame until the hinge levers are firmly seated into the hinge notches.
- 3 Fully open the door. If the door will not fully open, the notches in the bottoms of the hinge arms are not seated correctly onto the bottom edge of the slot. Lift the door off your range and repeat Step 2.
- 4 Push the hinge locks up into the locked position.
- 5 Close the oven door.

Replacing the oven light

CAUTION

- Before replacing oven light bulb, disconnect the electrical power to your range at the main fuse or circuit breaker panel. Failure to do so may result in electric shock or burn.
- The glass cover and bulb should be removed when cool. Touching hot glass with bare hands or a damp cloth can cause burns.

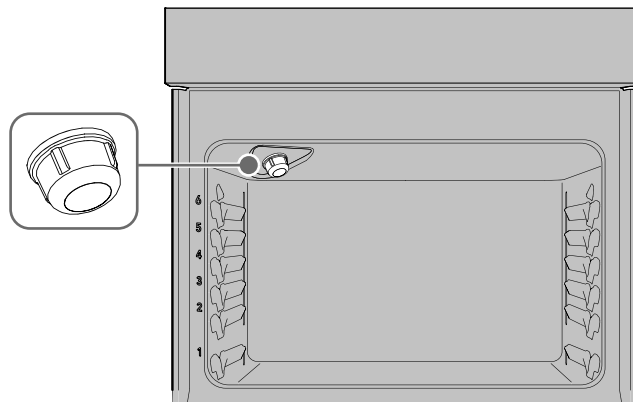

The interior oven light is located at the rear of the oven cavity and is covered by a glass shield. The glass shield must be in place whenever your oven is in use.

NOTE

To maximize the life of the new bulb, wear a cotton glove or use a tissue or paper towel when installing it. Touching the new bulb will shorten its life.

- 1 Unplug your range.
- 2 Remove the oven light shield by turning it a quarter turn counter-clockwise.
- 3 Replace bulb with a new G-9 type Halogen 40 watt appliance bulb.

- 4 Replace glass oven light shield by placing it over the bulb and rotating it clockwise.
- 5 Turn the power back on again by plugging in your range.
- 6 Be sure to reset the clock to the correct time.

Troubleshooting

Save time and money! Review the charts on the following pages first and you may not need to call for service. If you do have an ongoing issue that you can't resolve yourself, call Insignia Customer Care or your service provider for assistance.

Baking issues

ISSUE	CAUSE	POSSIBLE SOLUTION
Cookies and biscuits burnt on the bottom.	Failure to preheat your oven.	Preheat your oven to the correct temperature before putting in the cookies or biscuits.
	Using incorrect size cookie sheets or pans.	Use cookie sheets or pans that allow at least 2 in. (5.08 cm) of air space.
Cakes overcooked on the top or bottom.	Failure to preheat your oven.	Preheat your oven to the selected temperature before placing food in your oven.
	Rack position too high or low.	Use suggested rack position for baking.
	Oven too hot.	Set the oven temperature 25° F (13° C) lower than suggested.
Cakes undercooked in the center.	Your oven is set too hot.	Set oven temperature 25° F (13° C) lower than suggested.
	Incorrect pan size.	Use pan size suggested in recipe.
	Pan not centered in your oven.	Use proper rack position and place pan so there is at least 2 in. (5.1 cm) of space on all sides.
	Glass cookware used (slow heat conductor).	Reduce temperature and increase cook time or use shiny metal bake ware.
Cakes not level.	Your oven is not level.	Place a marked glass measuring cup filled with water in the center of the oven rack. If the water level is uneven, refer to the installation instructions for leveling your oven.
	Pan too close to oven wall or rack overcrowded.	Use proper rack position and place the pan so there is at least 2 in. (5.1 cm) of space on all sides of pan.
	Pan warped.	Don't use pans that are dented or warped.
	Oven light left on while baking.	Don't leave the oven light on while baking.
Baked goods not done when the cooking time is complete.	Your oven is too cool.	Set the oven temperature 25° F (13° C) higher than suggested and bake for the recommended time.
	Your oven is too crowded.	Be sure to remove all pans from your oven except the ones to be used for baking.
	The oven door is opened too often.	Open the oven door only after the shortest recommended baking time.

General issues

ISSUE	CAUSE	POSSIBLE SOLUTIONS
My range does not work.	Your range is not connected.	Make sure that the power cord is plugged into an outlet and that the outlet has power to it.
	Electrical power outage.	<ul style="list-style-type: none"> • Check your fuse box or breakers to make sure that the circuit is live. • Check your house lights to make sure that your power is on.

Oven issues

ISSUE	CAUSE	POSSIBLE SOLUTIONS
Poor baking results.	Using the wrong rack position or positioning your food incorrectly.	<ul style="list-style-type: none"> Use the recommended oven rack position. Center the food in your oven and space pans to allow air to circulate around them.
	Not preheating your oven.	Preheat your oven to the set temperature before placing food in your oven.
	Not using the correct cooking time.	Try adjusting the recipe's recommended cooking time. See Adjusting the oven temperature on page 18 if you think your oven is too hot or too cool.
Flames inside my oven or smoking from the oven vent.	Grease or food spills in the oven.	Wipe up excessive spills before using your oven. If flames or excessive smoke occur when using broil, see Setting your oven to broil on page 19.
My oven smokes excessively when using the broiler.	Broiler incorrectly set.	See Setting your oven to broil on page 19.
	Meat placed too close to the broil element.	Reposition the broil pan to provide proper clearance between the element and the meat.
	Meat has excessive fat.	Remove excess fat from the meat. Cut remaining fatty edges to prevent curling, but do not cut into lean.
	Grease buildup on the oven surfaces.	Regular cleaning is suggested when you frequently use the broiler. Grease or food splatters can cause excessive smoking.
The oven control panel beeps and displays an F or E error.	The oven control has detected a fault or error condition.	To clear the error, press the OFF button on the control panel. After the error code is cleared, try the bake or broil function again. If the F or E code error repeats, turn off the power to your range, wait five minutes, and then restore the power. Reset the clock with the correct time, then try the bake or broil function again. If the fault recurs, press the OFF button again and call a service technician.
My oven does not operate.	The time-of-day is not set.	The clock must be set in order for your oven to operate. See Setting the clock on page 16.
	The oven controls are not set properly.	Be sure the oven controls are set properly for the desired function. See Setting your oven to bake on page 18 and review instructions for the desired cooking function in this manual.

Cooktop issues

ISSUE	CAUSE	POSSIBLE SOLUTIONS
The surface element is too hot or not hot enough.	The surface control is not set correctly.	See Setting a single element on page 12 or Setting dual surface elements on page 13.
A surface element does not heat or does not heat evenly.	The wrong surface control knob is being used.	Be sure that the correct surface control knob is turned on for the element needed.
	Your cookware may be too light weight or may be warped.	Use only flat, evenly balanced, medium or heavyweight cookware. Flat pans heat better than warped pans. Cookware materials and the weight of the material affect heating. Medium and heavyweight pans heat evenly. Because lightweight pans heat unevenly, foods may burn easily.
There are areas of discoloration with a metallic sheen on the cooktop surface.	Mineral deposits from water and food may be present.	Remove them using a cooktop cleaning cream applied to the ceramic surface, then buff the surface with a non-abrasive cloth or sponge.

ISSUE	CAUSE	POSSIBLE SOLUTIONS
There are scratches or abrasions on the cooktop surface.	Coarse particles such as salt or hardened soils between cooktop and utensils can cause scratches.	Be sure the cooktop surface and the bottoms of utensils are clean before use. Small scratches do not affect cooking and will become less visible with time.
	Incorrect cleaning materials (those not recommended for ceramic-glass cooktop) have been used to clean your cooktop.	Apply a cooktop cleaning cream to the ceramic surface, then buff with a non-abrasive cloth or sponge.
	Cookware with a rough bottom may have been used.	Always make sure that you use smooth, flat-bottomed cookware.
There are metal marks on the cooktop.	Caused by sliding or scraping metal utensils on the cooktop surface.	Never slide metal utensils on the cooktop surface. Apply a cooktop cleaning cream to the ceramic surface, then buff with a non-abrasive cloth or sponge. For more information, see Cleaning and maintaining the cooktop on page 22.
There are brown streaks or specks on the cooktop surface.	Boil overs are cooked onto the surface of your cooktop.	When the cooktop is cool, use a razor blade scraper to remove cooked on food and spills. Apply a cooktop cleaning cream to the ceramic surface, then buff with a non-abrasive cloth or sponge. For more information, see Cleaning and maintaining the cooktop on page 22.

Miscellaneous issues

ISSUE	CAUSE	POSSIBLE SOLUTIONS
My range is not level.	Range not leveled properly.	Make sure that the floor is level, strong, and stable enough to adequately support your range.
	Floor not strong enough to support range.	If the floor is sagging or sloping, contact a carpenter to correct the situation.
	Your range was not installed correctly.	Place the oven rack in the center of your oven. Place a level on the oven rack. Adjust the leveling legs at the base of the appliance until your range is level.
	The alignment of your kitchen cabinets may make your range appear not level.	Be sure cabinets are square and have sufficient room for appliance clearance.
Cannot move my range easily. My range must be accessible for service.	Your kitchen cabinets may not be square or are built in too tightly.	Contact the builder or installer to make the appliance accessible.
	Carpeting may interfere with the appliance.	Provide sufficient space so that the appliance can be lifted over carpet. Installation over carpet is not advised. See the installation instructions for guidelines specific to your appliance.
My oven light does not work.	Oven light is not secure in the socket.	Make sure that your oven light is secure in the socket. See Replacing the oven light on page 24. The oven light only turns on when the Oven Light button on the display is pushed.
The power outage/clock flashes.	The power has been interrupted and restored.	The range will automatically resume its setting once the power is restored. You must reset the clock. If the oven was in use, you must reset it by pressing the OFF button, setting the clock and resetting any cooking function.
My oven or range is not working and the issue is not covered above.		Please contact your service provider or call us at Insignia 1-877-467-4289 Monday-Saturday 8 am to 9 pm CT.

Specifications

Dimensions (H x W x D)	47 3/4 x 30 x 26 in. (121.28 x 76.2 x 66.04 cm) Depth to edge of handle: 29 3/16 in. (74.14 cm) Depth with door open: 47 5/16 in. (120.17 cm)
Weight	Net: 132 lbs. (59.8 kg) Gross: 148 lbs. (67.1 kg)
Power requirements	208~240V at 40~50A
Cooktop elements	1 - 6 in. and 9 in. Dual 3000/1400W 2 - 9 in. Single 3000W 3 - 6 in. Single 1200W 4 - 6 in. Single 1200W
Oven element	Bake - 2600W @240V Broil - 3000W @ 240V
Oven temperatures	170° ~ 500° F (77° ~ 260° C)
Oven light	G-9 type 40 watt Halogen

ONE-YEAR LIMITED WARRANTY

Best Buy, or its Authorized Partner of Insignia branded products, warrants to you, the original purchaser of this new Insignia branded product ("Product"), that the Product shall be free of defects in the original manufacture of the material or workmanship for a period of one (1) year from the date of your purchase of the Product or the date of delivery (if later than the date of purchase) ("Warranty Period").

For this warranty to apply, your Product must be (i) purchased in the United States or Canada from a Best Buy branded retail store, online at www.bestbuy.com or www.bestbuy.ca, or from Best Buy's Authorized Partner, and (ii) packaged or sold with this warranty statement.

The term "Best Buy", as used in this warranty, refers to Best Buy branded retail stores, www.bestbuy.com, www.bestbuy.ca, and Best Buy's Authorized Partner.

Because Insignia cannot control the quality of products sold by unauthorized sellers, this warranty applies only to Products that were purchased from Best Buy or an Insignia Authorized Partner, unless otherwise prohibited by law. Insignia reserves the right to reject warranty claims for Products purchased from unauthorized sellers, including unauthorized websites.

REPAIR OR REPLACEMENT, AS PROVIDED UNDER THIS WARRANTY, IS YOUR EXCLUSIVE REMEDY FOR BREACH OF WARRANTY. INSIGNIA SHALL NOT BE LIABLE FOR ANY INCIDENTAL OR CONSEQUENTIAL DAMAGES FOR THE BREACH OF ANY EXPRESSED OR IMPLIED WARRANTY ON THIS PRODUCT, INCLUDING, BUT NOT LIMITED TO, LOST DATA, LOSS OF USE OF YOUR PRODUCT, LOST BUSINESS, OR LOST PROFITS. INSIGNIA PRODUCTS MAKES NO OTHER EXPRESS WARRANTIES WITH RESPECT TO THE PRODUCT. ALL EXPRESSED AND IMPLIED WARRANTIES FOR THE PRODUCT, INCLUDING BUT NOT LIMITED TO ANY IMPLIED WARRANTIES OF AND CONDITIONS OF MERCHANTABILITY AND FITNESS FOR A PARTICULAR PURPOSE, ARE LIMITED IN DURATION TO THE WARRANTY PERIOD SET FORTH ABOVE AND NO WARRANTIES, WHETHER EXPRESSED OR IMPLIED, WILL APPLY AFTER THE WARRANTY PERIOD. SOME STATES, PROVINCES, AND JURISDICTIONS DO NOT ALLOW LIMITATIONS ON (i) HOW LONG AN IMPLIED WARRANTY LASTS, (ii) EXCLUSION OR LIMITATION OF INCIDENTAL OR CONSEQUENTIAL DAMAGES, or (iii) LIMITATION OF INCIDENTAL OR CONSEQUENTIAL DAMAGES, SO THE ABOVE LIMITATIONS OR EXCLUSIONS MAY NOT APPLY TO YOU. THIS WARRANTY GIVES YOU SPECIFIC LEGAL RIGHTS, AND YOU MAY ALSO HAVE OTHER RIGHTS, WHICH VARY FROM STATE TO STATE OR PROVINCE TO PROVINCE.

How long does the coverage last?

The Warranty Period lasts for 1 year (365 days) from the date you purchased the Product or the date of delivery (if later than the date of purchase). Your purchase date is printed on the receipt you received with the Product. In the event that Authorized Partner ceases to sell the covered Insignia branded product, this warranty shall terminate for that product and there shall be no repair or replacement of the Product.

What does this warranty cover?

During the Warranty Period, if the original manufacture of the material or workmanship of the Product is determined to be defective by an authorized Insignia repair center or store personnel, Insignia will (at its sole option): (1) repair the Product with new or rebuilt parts; or (2) replace the Product at no charge with new or rebuilt comparable products or parts. Products and parts replaced under this warranty become the property of Insignia and are not returned to you. If service of Products or parts are required after the Warranty Period expires, you must pay all labor and parts charges. This warranty lasts as long as you own your Insignia Product during the Warranty Period. Warranty coverage terminates if you sell or otherwise transfer the Product.

How to obtain warranty service?

If you purchased the Product at a Best Buy retail store location or from a Best Buy online website (www.bestbuy.com or www.bestbuy.ca), please take your original receipt and the Product to any Best Buy store. Make sure that you place the Product in its original packaging or packaging that provides the same amount of protection as the original packaging. If you purchased your Product from an Authorized Partner, call Insignia at 1-877-467-4289.

To obtain warranty service, in the United States and Canada call 1-877-467-4289. Call agents may diagnose and correct the issue over the phone.

If you purchased the Product from an Authorized Partner other than Best Buy, please call 1-888-BESTBUY in the United States or 1-866-BESTBUY in Canada. You will be asked to provide proof of purchase and to return your Product to Best Buy. Make sure that you put the Product in its original packaging or packaging that provides the same amount of protection as the original packaging.

Where is the warranty valid?

This warranty is valid only in the United States and Canada to the original purchaser of the product from an Authorized Partner, in the country where the original purchase was made.

What does the warranty not cover?

This warranty does not cover:

- Food, beverage, and or medicine loss/spoilage.
- Damage to other products caused by a power surge or other similar issue while connected to the Product.
- Customer instruction/education.
- Installation.
- Set up adjustments.
- Cosmetic damage.
- Damage due to weather, lightning, and other acts of God, such as power surges.
- Accidental damage.
- Misuse.
- Abuse.
- Negligence.
- Commercial purposes/use, including but not limited to use in a place of business or in communal areas of a multiple dwelling condominium or apartment complex, or otherwise used in a place of other than a private home.
- Modification of any part of the Product, including the antenna.
- Display panel damaged by static (non-moving) images applied for lengthy periods (burn-in).
- Damage due to incorrect operation or maintenance.
- Connection to an incorrect voltage or power supply.
- Damage due to attempted repair by any person not authorized by Insignia to service the Product.
- Products sold "as is" or "with all faults".
- Consumables, including but not limited to batteries (i.e. AA, AAA, C etc.).
- Products where the factory applied serial number has been altered or removed.
- Loss or Theft of this product or any part of the product.
- Display panels containing up to three (3) pixel failures (dots that are dark or incorrectly illuminated) grouped in an area smaller than one tenth (1/10) of the display size or up to five (5) pixel failures throughout the display. (Pixel based displays may contain a limited number of pixels that may not function normally).
- Failures or Damage caused by any contact including but not limited to liquids, gels or pastes.

Contact Insignia:
1-877-467-4289

www.insigniaproducts.com

INSIGNIA is a trademark of Best Buy and its affiliated companies.

*Distributed by Best Buy Purchasing, LLC

7601 Penn Ave South, Richfield, MN 55423 U.S.A

©2025 Best Buy. All rights reserved.

INSIGNIA™

Part #A27770403

**For product inquiries, please contact us with the information below:
1-877-467-4289**

www.insigniaproducts.com

INSIGNIA is a trademark of Best Buy and its affiliated companies.

Distributed by Best Buy Purchasing, LLC

7601 Penn Ave South, Richfield, MN 55423 U.S.A.

©2025 Best Buy. All rights reserved.

V4 ENGLISH
25-0449