

US

Model.URTM030

# Strol 2E

## Under Desk Treadmill

### USER MANUAL

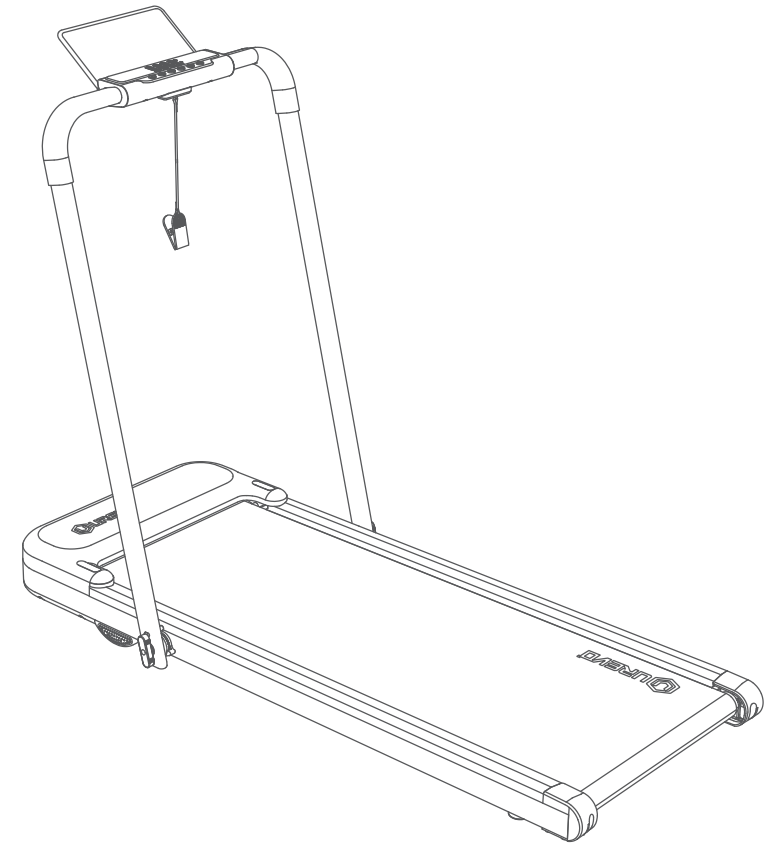

**IMPORTANT:** Read all instructions carefully before using this product. Retain this owner's manual for future reference. The specifications of this product may vary from this photo, subject to change without notice.

**Manufacturer: Shenzhen Yile Dynamic Technology Co., LTD.**

Address: 1205-1206, Tianliao Building, Tangchang Road, Tanglang Community, Taoyuan Street, Nanshan District, Shenzhen, China

Version: 5.0



MADE IN CHINA



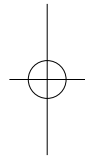

# TABLE OF CONTENTS

- 02 CUSTOMER SERVICE
  - 03 IMPORTANT SAFETY INSTRUCTIONS
  - 05 PRODUCT AND ACCESSORIES
  - 06 SPECIFICATION
  - 07 PRODUCT INTRODUCTION
  - 08 HOW TO USE
  - 11 OPERATION
  - 13 WORKOUT WITH FITNESS APP
  - 14 CARE AND MAINTENANCE
  - 16 ERROR CODE
  - 17 TROUBLESHOOTING
  - 18 WARRANTY
- 

# 1 CUSTOMER SERVICE

## IMPORTANT: FOR UREVO ONLY

For damaged or defective product, questions, replacement parts or any other service support, please contact our customer service department by the below methods:

**services@urevo.com**

Response Time: 24-48 hours

Emailing us with the **Order ID** will be the best method to receive a response during peak business hours.

**Website: www.urevo.com**

**US Support Hotline:** (1)844-998-2473

**Phone Service Hours:** Mon-Sun: 9AM-12PM, 1PM-6PM (PST)

**PLEASE DO NOT RETURN THIS PRODUCT WITHOUT ASKING OUR CUSTOMER SERVICE FIRST.**

**SCAN THIS QR CORD TO GET THE PRODUCT INSTALLATION OR MAINTENCE VIDEOS**



Urevo YouTube Video

# 2 IMPORTANT SAFETY INSTRUCTIONS

## **DANGER - To reduce the risk of electric shock:**

1. Always unplug this treadmill from the electrical outlet immediately after using and before cleaning.

## **WARNING - To reduce the risk of burns, fire, electric shock, or injury to persons:**

1. An treadmill should never be left unattended plugged in. Unplug from outlet when not in use, and before putting on or taking off parts.
2. Do not operate under blanket or pillow. Excessive heating can occur and cause fire, electric shock, or injury to persons.
3. Close supervision is necessary when this treadmill is used by, on, or near children, invalids, or disabled persons.
4. Use this treadmill only for its intended use as described in this manual. Do not use attachments not recommended by the manufacturer.
5. Never operate this treadmill if it has a damaged cord or plug, if it is not working properly, if it has been dropped or damaged, or dropped into water. Return the treadmill to a service center for examination and repair.
6. Do not carry this treadmill by supply cord or use cord as a handle.
7. Keep the cord away from heated surfaces.
8. Never operate the treadmill with the air openings blocked. Keep the air openings free of lint, hair, and the like.
9. Never drop or insert any object into any opening.
10. Do not use outdoors.
11. Do not operate where aerosol (spray) products are being used or where

oxygen is being administered.

12. Caution - To reduce the risk of injury from moving parts - Unplug before servicing.
13. Warning - To reduce the risk of Electric shock - Unplug before cleaning or servicing.
14. Warning - Risk of personal injury - Keep children under the age of 13 away from machine.
15. To disconnect, turn all controls to the position, then remove plug form outlet.
16. Connect this treadmill to a properly outlet only. See grounding instructions.
17. This treadmill is not intended for use by persons with reduces physical, sensory or mental capabilities, or lack of experience and knowledge, unless they have been given supervision or instruction concerning use of the treadmill by a person responsible for their safety. Keep children under the age of 13 away from this machine.
18. **The maximum weight capacity for this product is 265lbs /120kg. DO NOT EXCEED MAXIMUM WEIGHT CAPACITY.**

## **SAVE THESE INSTRUCTIONS**

### **GROUNDING INSTRUCTIONS:**

This product must be grounded. If it should malfunction or breakdown, grounding provides a path of least resistance for electric current to reduce the risk of electric and a grounding plug. The plug must be plugged into an appropriate outlet

that is properly installed and grounded in accordance with all local codes and ordinances.

**DANGER** - Improper connection of the equipment-grounding conductor can result in a risk of electric shock. Check with a qualified electrician or serviceman if you are in doubt as to whether the product is properly grounded. Do not modify the plug provided with the product - if it will not fit the outlet, have a proper outlet installed by a qualified electrician.

**FCC STATEMENT :**

This device complies with part 15 of the FCC rules.

Operation is subject to the following two conditions:

(1) This device may not cause harmful interference, and

(2) This device must accept any interference received, including interference that may cause undesired operation.

(3) Any Changes or modifications not expressly approved by the party responsible for compliance could void the user's authority to operate the equipment.

**Note:** This equipment has been tested and found to comply with the limits for a Class B digital device, pursuant to part 15 of the FCC Rules. These limits are designed to provide reasonable protection against harmful interference in a residential installation. This equipment generates, uses and can radiate radio frequency energy and, if not installed and used in accordance with the instructions, may cause harmful interference to radio communications. However, there is no guarantee that interference will not occur in a particular installation. If this equipment does cause harmful interference to radio or television reception, which can be determined by turning the equipment off and on, the user is encouraged to try to correct the interference by one or more of the following measures:

- Reorient or relocate the receiving antenna.
- Increase the separation between the equipment and receiver.

- Connect the equipment into an outlet on a circuit different from that to which the receiver is connected.
- Consult the dealer or an experienced radio/TV technician for help.

This device complies with RSS210 of Industry Canada. Cet appareil se conforme à RSS210 de Canada d'Industrie. This device complies with Industry Canada license-exempt RSS standard(s). Operation is subject to the following two conditions: (1) this device may not cause interference, and (2) this device must accept any interference, including interference that may cause undesired operation of the device. appareils radio exempts de licence. Son fonctionnement est sujet aux deux conditions suivantes:

(1) le dispositif ne doit pas produire de brouillage préjudiciable, et (2) le dispositif doit accepter tout brouillage reçu, y compris un brouillage susceptible de provoquer un fonctionnement indésirable.

Radiation Exposure Statement: The product comply with the Canada portable RF exposure limit set forth for an uncontrolled environment and are safe for intended operation as described in this manual.

The further RF exposure reduction can be achieved if the product can be kept as far as possible from the user body or set the device to lower output power if such function is available.

Déclaration d'exposition aux radiations : Le produit est conforme aux limites d'exposition pour les appareils portables RF pour les États-Unis et le Canada établies pour un environnement non contrôlé.

Le produit est sûr pour un fonctionnement tel que décrit dans ce manuel. La réduction aux expositions RF peut être augmentée si l'appareil peut être conservé aussi loin que possible du corps de l'utilisateur ou que le dispositif est réglé sur la puissance de sortie la plus faible si une telle fonction est disponible.

This Class B digital apparatus complies with Canadian ICES-003.

Cet appareil numérique de la classe B est conforme à la norme NMB-003 du Canada.

# 3 PRODUCT AND ACCESSORIES

Please carefully check whether the contents of the package are complete and intact. If there is any missing and damage, please contact the seller.

## Accessories

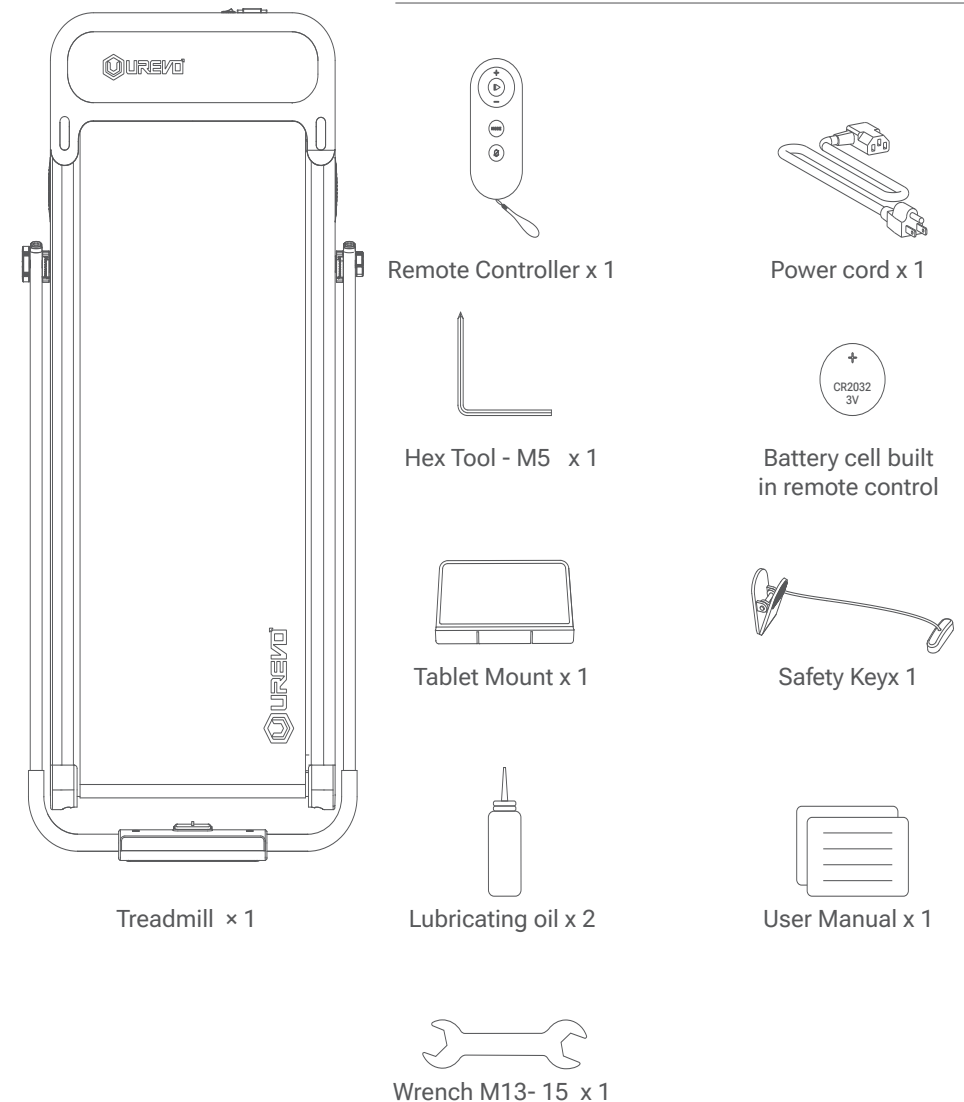

# 4 SPECIFICATION

Product configuration	Detailed parameters	Product configuration	Detailed parameters
Product dimension (Folded)	130 x 57.3 x 11.7 cm	Product dimension (Unfold)	122 x 57.3 x 98.7 cm
	51.2 x 22.6 x 4.6 inch		48 x 22.6 x 38.9 inch
Running Area	38 X 102 cm	Minimum speed	0.6 mph
	15 x 40.2 inch		
Gross weight	24.8KG	Maximum speed	6.2 mph
	54.7Lbs		
Net weight	21.4KG	Rate voltage	110 - 120V ~
	47.2 Lbs	Peak horsepower	2.25 hp
Maximum load	120 KG	Rated power	550W
	265 Lbs	Suggested age	14-60 years old

# 5 PRODUCT INTRODUCTION

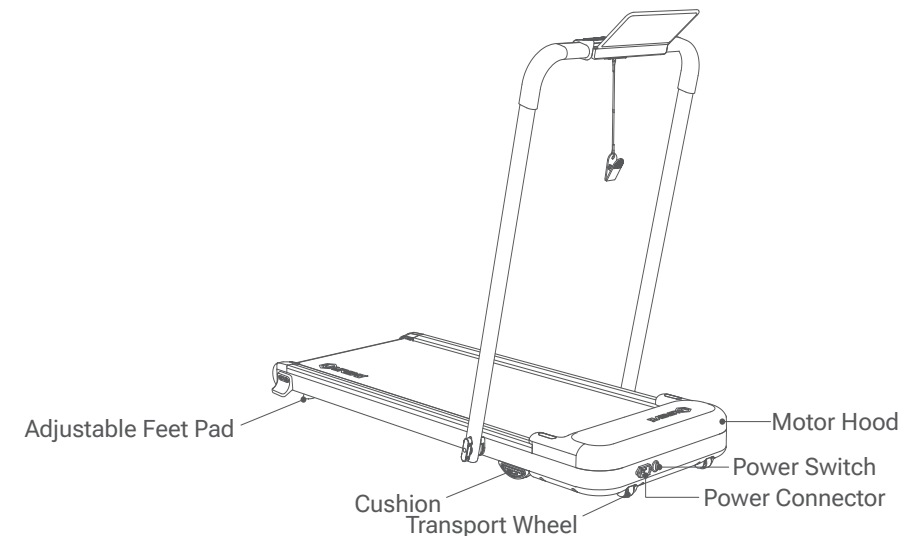
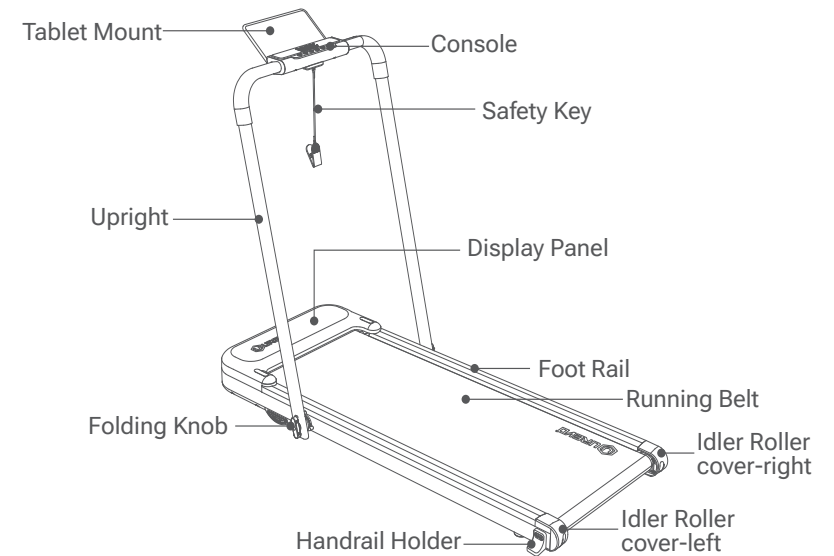

# 6 HOW TO USE

## Unfold to run

1. Open the packaging box and take out the treadmill with the related accessories from the box.

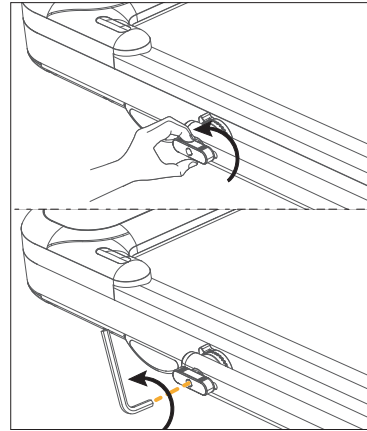

2. Twist folding knobs till loosen or assist with hex tool as figure show (same operation on both sides).

3. Lift up handrail until end position.

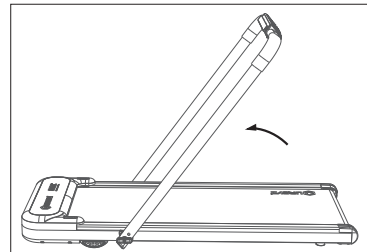

4. Re-twist folding knobs till tightened or assist with hex tool as figure show (same operation on both sides).

**NOTE : Handrail MUST fixed security before running.**

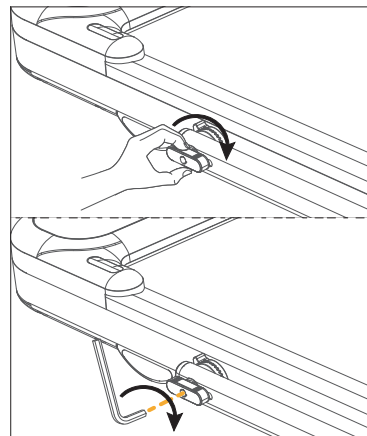

5. Install tablet mount.

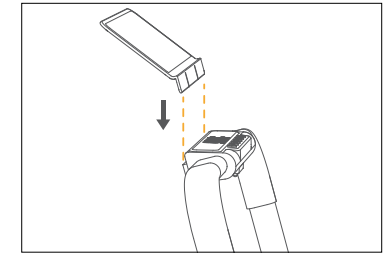

6. Plug in power cord.

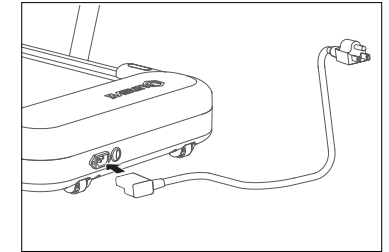

7. Power on and start running.

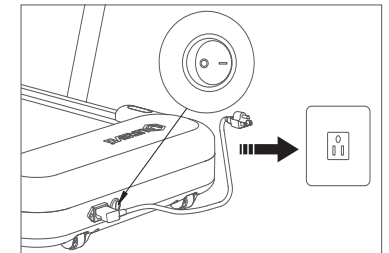

## Folded to walk

1. Twist folding knobs till loosen or assist with hex tool.

2. Fold down handrail until in lined with foot rail.

3. Re-twist folding knobs till tightened or assist with hex tool as figure show.

**NOTE : Handrail MUST fixed security before walking.**

4. Start to walk mode with remote control.

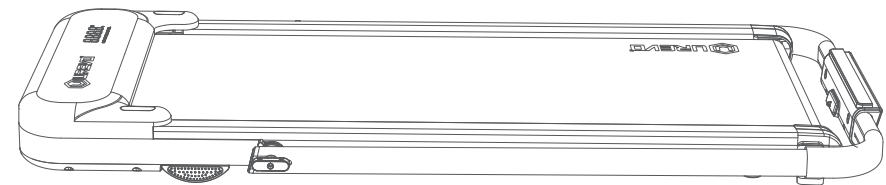

## Moving

1. If transportation needs, unplug power cord and lifting the terminal of treadmill.
2. Easy to transport treadmill with bottom transportation wheel assists, like as wheelbarrow.

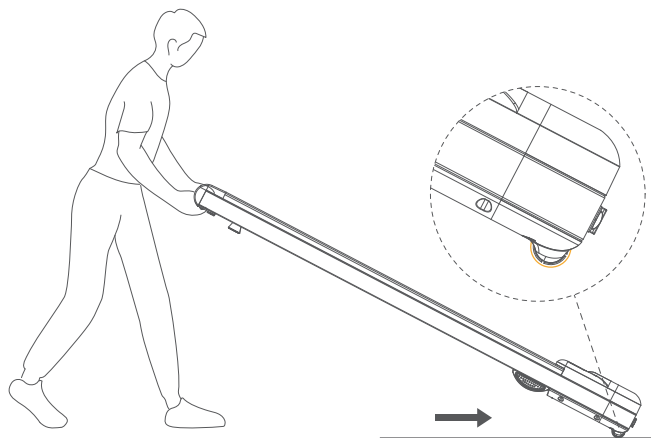

**NOTE :** Before move and storage, please make sure the power switch is off and power cord is unplugged.

# 7 OPERATION

## Console

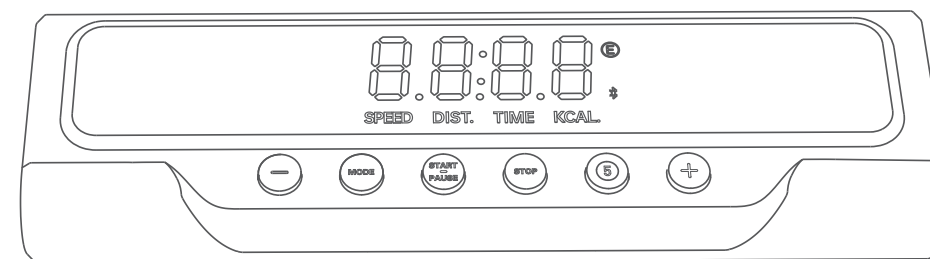

### Button Function

Button	Function
	Short or long press this button to decelerate at per 0.2 mph.
	Customize countdown workout programs ( like as: Time; Distance; Calories )
	<ul style="list-style-type: none"> <li>• Short press this button to start the treadmill at the speed of 0.6 mph.</li> <li>• Short press this button to have a pause as you exercise. To resume workout, re-press it again.</li> </ul>
	Safety stop (unplug safety key in case of emergency) Short press this button to stop the treadmill in running mode.
	Speed shortcut button: Press this button directly to adjust the speed to 5mph.
	Short or long press this button to accelerate at per 0.2 mph.

## Display Screen

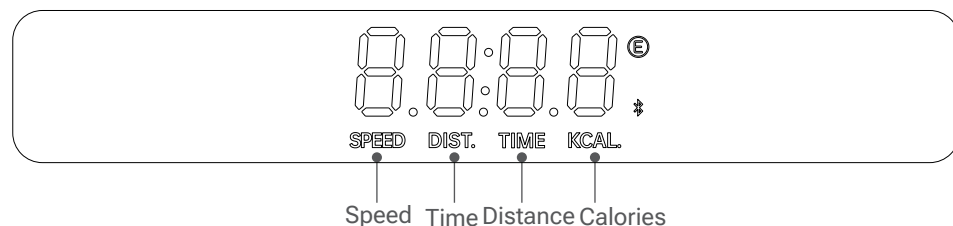

Name	Range	Display
Speed	0.6-6.2 mph	The speed of walking belt;
Calories	0-6553 Kcal	The approximate number of calories of you have burned;
Time	00:00-99:59 minutes	<ul style="list-style-type: none"> <li>The time elapsed time ;</li> <li>Once initial exercise duration over than 100 minutes, Non-stop and retiming.</li> </ul>
Distance	0.00-99.99miles	The distance that you have walked or run;
ERP indicator light	/	Standby mode , indicator  flashing slowly.

## Remote Control

Buttons	Operation	Note
	Short press	Start the walking treadmill
	Long press for 2"	<b>When the walking treadmill stop</b> (all datas recover to 0), the screen will display "END". 10 minutes later, only ERP indicator  flash; Press any buttons to wake up the treadmill.
	Short press (in work mode)	The screen will display "PAU", previous workout metrics will be preserved automatically if pause time no longer than 10minutes, otherwise metrics data will be recovered to "0"; Press any buttons to wake up the treadmill. The treadmill will re-start at the minimum speed by re-pressing .
<b>MODE</b>	Short press	Customize countdown workout programs ( like as: Time; Distance; Calories )
<b>+</b>	Short press	Long press over 0.5 seconds, the speed will be increased continuously.
<b>-</b>	Short press	Long press over 0.5 seconds, the speed will be decreased continuously.
	Short press	Short press: Muted buzzer voices

**Note: The speed can only be accelerated to 4.0 mph via the remote control. To accelerate to 6.2 mph, you need to press "+" button on the console.**

# 8 WORKOUT WITH FITNESS APP

Strol 2E walking treadmill has integrated with Bluetooth® 5.0 connectivity with allow it to work with Urevo App or others Fitness App (compatible with Zwift and Kinomap App) With Urevo App, it can be accessed through your device when synced to the console of exercises, you receive workout reports on your device for coaching your exercise planning, Urevo App also offers a variety of professional courses.

1. Scan QR code to download and install Urevo Fitness APP.



- Free of charge to create membership and log in.
- Bluetooth connectivity walking treadmill to your device.
  - Connected: solid light
  - Searching or failed connection: flashing
  - Updating: quick flashing
- Enjoy your exercises.

# 9 CARE AND MAINTENANCE

## Symptom : walk belt off centered or slips.

### Centering walk belt process as follow :

1. Power off treadmill and unplug the power cord .
2. Manual centering process as follow:
  - If the walk belt has shifted to left, use the hex tool to turn the left idler roller screw clockwise  $\frac{1}{4}$  of a turn(refer to figure 1).
  - If the walk belt has shifted to right, use the hex tool to turn the right idler roller screw clockwise  $\frac{1}{4}$  of turn(refer to figure 2).
3. Treadmill MUST work 1-2minutes. Repeat manual centering process until the walk belt is centered.

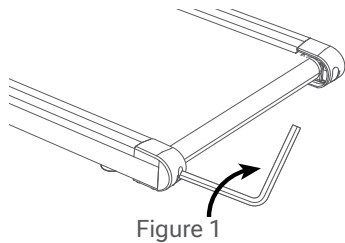

### Belt slip correcting process as follow :

1. Power off treadmill before operation.
2. Using the hex tool, turn both idler roller screws clockwise  $\frac{1}{2}$  of turn(refer to figure 3).
3. After corrected, please attempts to walking 1-2 minutes under 1.0mph speed setting. Repeat until the walk belt is properly tightened.

**Note: The Tread-belt should not be adjusted too tightly, otherwise it will be damaged.**

### Attentions

1. To prevent any injury, don't place any debris around treadmill before maintenance process.
2. MUST use associated hex tool.
3. Take care at maintenance process. Do not pinch fingers.

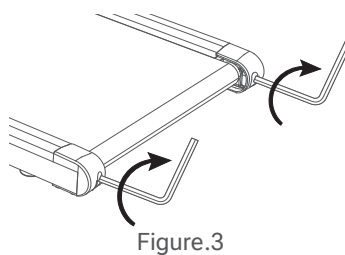
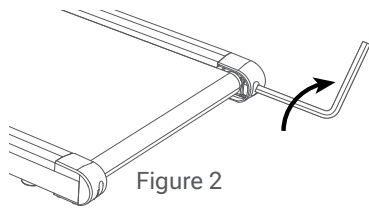

## Belt lubrication process, follow instruction below to lubricate belt.

**FRIENDLY REMINDER : HIGHLY RECOMMEND TO PROCESS BELT LUBRICATION BEFORE INITIAL USE.**

1. Power off appliance and unplug cord.
2. Using the hex tool, turn both idler roller screws counterclockwise till belt loosen and lifting easily.
 

**Tips: please markdown hex tool rotating cycles when loosen belt, which use for adapting belt tension after lubrication process.**
3. Lifting edges of belt and spraying lubrication oil at center of walk platform evenly. Not necessary to apply spray lubrication oil on entire walk platform.
4. Lubrication oil volume Per time of maintenance: 5-10mL.
 

**Attention: it would causes of belt slip if spray too much.**
5. Using the hex tool, turn the both idler screws clockwise as previous markdown number of turns until walk belt tighten properly.
6. Power on appliance and workout for a few minutes, in order to spread lubrication oil to whole belt surface evenly.
 

Lubrication frequency: High recommend 125 Miles Per time.

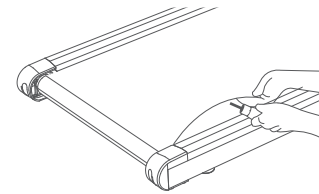

## Treadmill cleaning.

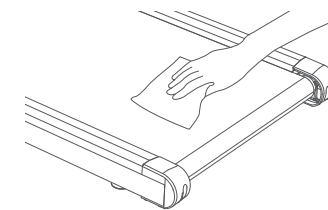

1. Power off treadmill and unplug power cord before cleaning.
2. Wipe and clean with damp cloth, Do not cleaning with acidic or caustic detergents.
3. Do not clean opposite of walk belt.
4. Its normal few black powders residual under treadmill after long working.

# 10 ERROR CODE

Error Code	Fault Analysis	Resolutions
E01	Communcation interrupted between contoller and numeric display.	Unscrew motor hood and verify connection between controller and numeric display. Please contact with after sale service if E01 code has not been eliminated. <b>Notice: Always power off and unplug power cord before processing.</b>
E02	Motor open circuit	1. Unscrew motor hood to verify motor terminals connection . 2. Please contact with after sale service if problem CAN NOT solved by above process.
E03	Flame protection	1. Unscrew motor hood and verify connection between controller and motor. 2. Power supply interrput due to connector loosen or out, please unscrew motor hood to check. 3. Please contact with after sale service if problem CAN NOT solved by above process.
E04	Over current protection	1. Due to user over limited 120Kg. 2. Open to check any foreign objects blocked moving parts. ( such as: drive motor, idler roller, driver roller, walking belt ) 3. Walking belt is overtightened or lack of lubricant. ( please see detail chapters relate to belt tension and lubricant process )
E05	Communcation interrupted between signal cable and console.	1. Unscrew console box and verify connection between singal cable and console. 2. Unscrew console box and verify internal lead wires whether are damaged or pierced. 3. Replace new console PCBA board.
E10	Lack of safety key	Attach safety key under console.

Once error code happened, you MUST stop workout immediately, Please contact with after sale service if problem CAN NOT be solved after restart.

# 11 TROUBLESHOOTING

Problem	Fault Analysis	Resolutions
No working	1. Power rock switch dyfunction 2. Power supply interrputed. 3. Power cord damaged	1. Replace new power rock switch if it doesn't light on. 2. Make sure that power cord is plugged into properly grounded outlet. 3. Replace new power cable.
Walking belt slips	Walking belt loosen	Tighten walking belt tension with hex tool ( 1/4 a turn both idler roller screw clockwise)
Remote control does not work	1. Incorrect use of default 2. Battery power shortage. 3. Remote control maulfuction	1. Remotor control should directly aiming to receiver port when in use. 2. Replace new battery cells. 3. Replace new remote control.
Friction noise	Walking belt off center.	See details of walking belt tension chapter.

# 12 WARRANTY

## MANUFACTURER'S LIMITED WARRANTY

UREVO warrants to the original purchaser that this product is free from defects in material and workmanship when used for the purpose intended, under the conditions that it has been installed and operated in accordance with UREVO Owner's Manual. UREVO's obligation under this warranty applies to the following:

### Warranty Coverage

Standard Warranty for Entire Unit: 1 Year

### Exclusions from Warranty Coverage:

UREVO does not warrant against and is not responsible for, and no implied warranty shall be deemed to cover, any product failure, product malfunction, or damages attributable to:

1. Improper installation and/or failure to abide by UREVO's installation guidelines;
2. Use of this product beyond normal home use, or in an application for which it was not designed;
3. Cosmetic items such as scratches, dents or discolorations;
4. Damage caused by normal wear and tear, vandalism, accidental or by animals;
5. Any act of Nature (such as fire, flooding, snow, ice, hurricanes, earthquakes, lightnings or other natural disasters), environmental condition (such as air pollution, mold, mildew, etc.), or staining from foreign substances (such as dirt, grease, oil, etc.);
6. Normal weathering due to exposure to sunlight, weather and atmosphere which can cause colored surfaces to among other things, flake, chalk, accumulate dirt or stains.
7. Improper operation, alteration, handling, storage, abuse or neglect of the products.

**UREVO , using its sole discretion, will either repair or replace free of charge any part(s) proven to be defective under normal home use. Any repair or replacement shall provide no new warranty coverage, but shall retain only the remaining portion of the original product's warranty. This warranty is offered only to the original purchaser and is not transferable. Proof of original purchase is required.**

When ordering replacement parts please have the following information ready:

1. Order Number
2. Description of Parts  
(Adding photos or videos would be helpful)
3. Part Number
4. Date of Purchase

### Warning!

1. Remove and immediately recycle or dispose of used batteries according to local regulations and keep away from children. Do NOT dispose of batteries in household trash or incinerate.
2. Even used batteries may cause severe injury or death.
3. Call a local poison control center for treatment information.
4. The compatible battery type CR2032 3V.
5. Non-rechargeable batteries are not to be recharged.
6. Do not force discharge, recharge, disassemble, heat above 50°C/122°F or incinerate. Doing so may result in injury due to venting, leakage or explosion resulting in chemical burns.
7. Ensure the batteries are installed correctly according to polarity (+ and -).
8. Do not mix old and new batteries, different brands or types of batteries, such as alkaline, carbon-zinc, or rechargeable batteries.
9. Remove and immediately recycle or dispose of batteries from equipment not used for an extended period of time according to local regulations.
10. Always completely secure the battery compartment. If the battery compartment does not close securely, stop using the product, remove the batteries, and keep them away from children.

<b>⚠ WARNING</b>	
<ul style="list-style-type: none"><li>• <b>INGESTION HAZARD:</b> This product contains a button cell or coin battery.</li><li>• <b>DEATH</b> or serious injury can occur if ingested.</li><li>• A swallowed button cell or coin battery can cause <b>Internal Chemical Burns</b> in as little as <b>2 hours</b></li><li>• <b>KEEP</b> new and used batteries <b>OUT OF REACH of CHILDREN</b></li><li>• <b>Seek immediate medical attention</b> if a battery is suspected to be swallowed or inserted inside any part of the body.</li></ul>	