

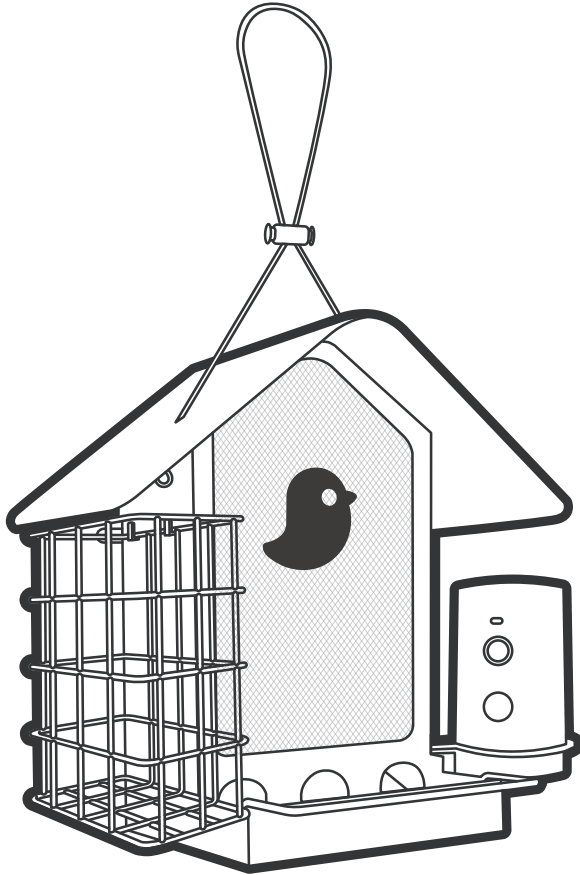

Birdfy

# User Manual

Birdfy Feeder Metal V



EN

ES

FR

# Catalog

What's in the Box .....	1-2
About the Product .....	3
Camera User Guide .....	4
Charging .....	5-6
Downloading the Birdfy App .....	7-8
Assembly .....	9-10
Outdoor Installation .....	11
Adding Birdseed and Suet Cake .....	12-14
Cleaning .....	15
Support .....	16-18
The Birdfy Community .....	19
Warning .....	21-23

# Catálogo

Contenido de la caja .....	1-2
Sobre el producto .....	3
Guía de uso de la cámara .....	4
Carga .....	5-7
Descargar la app Birdfy .....	8-9
Montaje .....	10-11
Instalación en exteriores .....	12
Añadir semillas y pastel de sebo .....	13-15
Limpieza .....	16
Soporte .....	17-19
Comunidad Birdfy .....	20
Advertencias .....	21-23

# Catalogue

Contenu de la boîte .....	1-2
À propos du produit .....	3
Guide d'utilisation de la caméra .....	4
Charge .....	5-7
Télécharger l'application Birdfy .....	8-9
Assemblage .....	10-11
Installation extérieure .....	12
Ajout de graines et de gâteau de suif .....	13-15
Nettoyage .....	16
Support .....	17-19
La communauté Birdfy .....	20
Avertissements .....	21-23

# What's in the Box

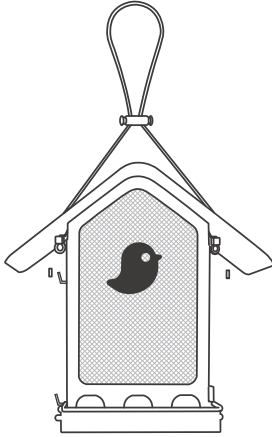

Feeder  
Comedero  
Mangeoire



Installation accessories  
Accesorios de instalación  
Accessoires d'installation



Camera mount  
Soporte de cámara  
Support de caméra



Charging cable  
Cable de carga  
Câble de chargement



Camera  
Cámara  
Caméra

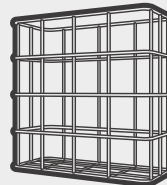

Side Suet Feeder  
Suet Feeder lateral  
Suet Feeder latéral



User Manual  
Manual de usuario  
Manuel d'utilisateur



Tips for Beginner  
Consejos para Principiantes  
Conseils pour Débutants

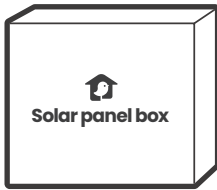

\*Solar panel box  
\*Caja del panel solar  
\*Boîte du panneau solaire

\*Please note that if you ordered the no-solar bundle, your package will not include a solar panel.

\*Tenga en cuenta que si pidió el paquete sin panel solar, su paquete no incluirá un panel solar.

\*Veuillez noter que si vous avez commandé le forfait sans panneau solaire, votre colis n'inclura pas de panneau solaire.

# About the Product

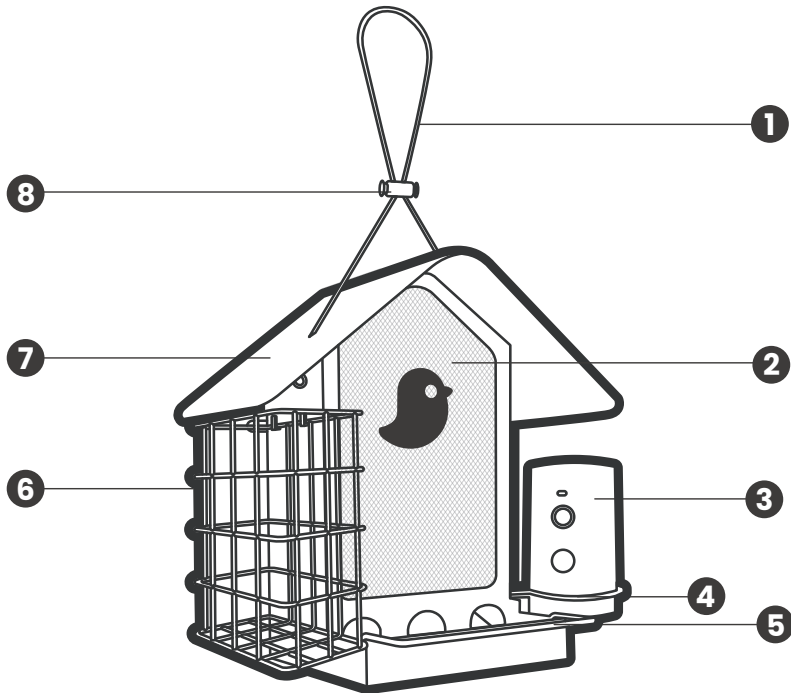

**1**

Metal hanging cable  
Cable metálico para colgar  
Câble métallique de suspension

**2**

Seed bin  
Depósito de semillas  
Bac à graines

**3**

Camera  
Cámara  
Caméra

**4**

Camera mount  
Soporte de cámara  
Support de caméra

**5**

Perch  
Posadero  
Perchoir

**6**

Side Suet Feeder  
Suet Feeder lateral  
Suet Feeder latéral

**7**

Seed bin roof  
Techo del depósito de semillas  
Toit du bac à graines

**8**

Cord lock  
Bloqueo de cable  
Verrou de câble

# Camera User Guide

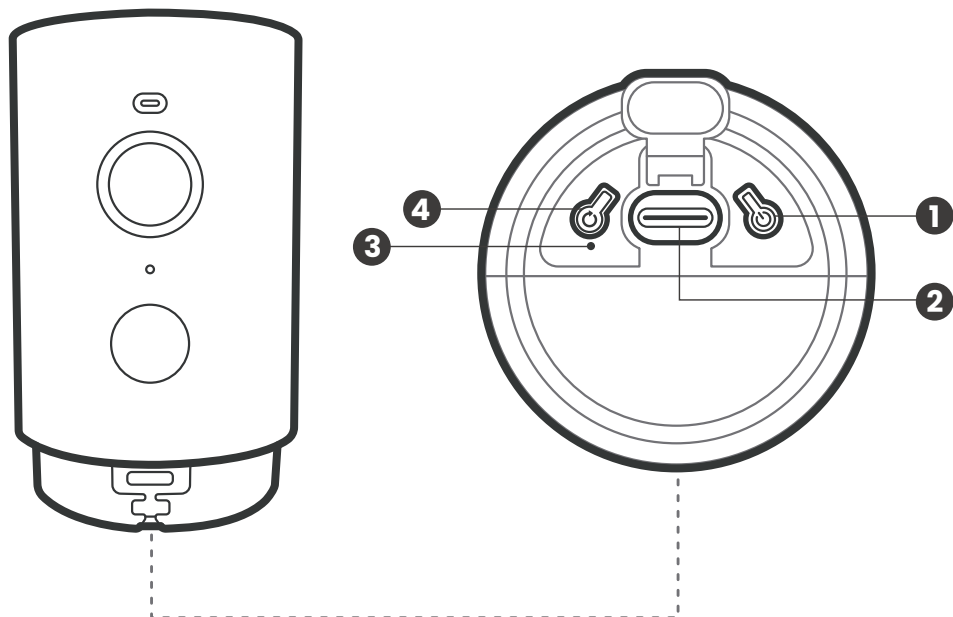

**1**

Power button  
Botón de encendido  
Bouton d'alimentation

**2**

Charging port  
Puerto de carga  
Port de chargement

**3**

Status light  
Luz de estado  
Témoin lumineux

**4**

Reboot button  
Botón de reinicio  
Bouton de réinitialisation

# Charging

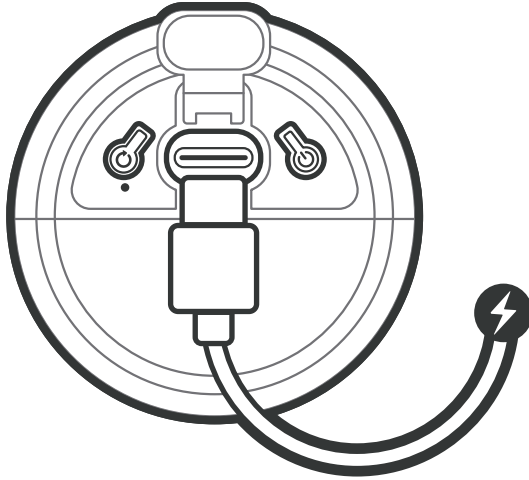

## **Fully charge the camera before use**

For safety reasons, the camera is not fully charged when packaged. Please use the included charging cable (DC 5V / 1.5A) found in the accessory box to fully charge the camera before first use.

## **Cargue completamente la cámara antes de usarla**

Por razones de seguridad, la cámara no está completamente cargada cuando se empaqueta. Por favor, utilice el cable de carga incluido (DC 5V / 1.5A) que se encuentra en la caja de accesorios para cargar completamente la cámara antes del primer uso.

## **Chargez complètement la caméra avant de l'utiliser**

Pour des raisons de sécurité, la caméra n'est pas complètement chargée lorsqu'elle est emballée. Veuillez utiliser le câble de charge inclus (DC 5V / 1.5A) situé dans la boîte d'accessoires pour charger complètement la caméra avant la première utilisation.

<b>Camera Status Light</b> <b>Luz de estado de la cámara</b> <b>Le voyant d'état de la caméra</b>	<b>Description</b> <b>Descripción</b> <b>Description</b>
Solid red Rojo fijo Rouge fixe	Charging Cargando En charge
Solid blue Azul fijo Bleu fixe	Working En funcionamiento En fonctionnement
Flashing blue Azul intermitente Bleu clignotant	Wi-fi Config Mode Modo de configuración Wi-Fi Mode configuration Wi-Fi
None Sin luz Aucune lumière	Sleep / Power off En reposo / Apagado Veille / Éteint



When charging and operating, both the ambient temperature and camera temperature should be within 14°F to 113°F (-10°C to 45°C). If the camera has been exposed to low temperatures for an extended period, it should be brought back to room temperature before charging.

Durante la carga y el funcionamiento, tanto la temperatura ambiente como la de la cámara deben estar entre 14°F y 113°F (-10°C a 45°C). Si la cámara ha estado expuesta a bajas temperaturas durante un período prolongado, debe llevarse a temperatura ambiente antes de cargarla.

Lors de la charge et de l'utilisation, la température ambiante et celle de la caméra doivent se situer entre 14°F et 113°F (-10°C à 45°C). Si la caméra a été exposée à des températures basses pendant une période prolongée, elle doit être ramenée à température ambiante avant la recharge.

# Downloading the Birdfy App



**Follow the in-app instructions to set up your Birdfy**

**Sigue las instrucciones dentro de la aplicación para configurar tu Birdfy**

**Suivez les instructions dans l'application pour configurer votre Birdfy**

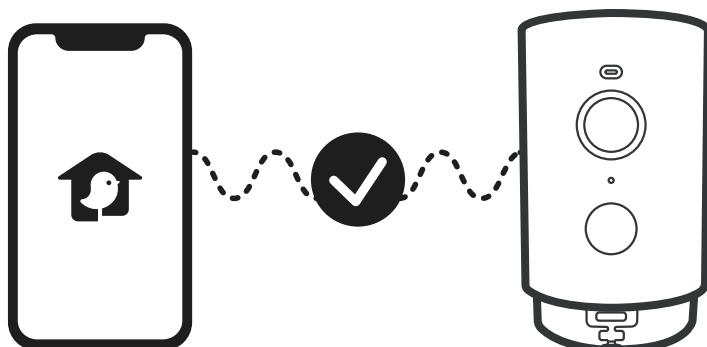

## **Bird Identification**

- For product labeled Lifetime Free AI, bird identification feature is included and activated automatically, no further action needed.
- For product labeled AI by Subscription, you need to subscribe on [my.birdfy.com](https://my.birdfy.com) to access this feature.

## **Identificación de aves**

- Para productos etiquetados como AI gratuita de por vida, la función de identificación de aves está incluida y se activa automáticamente, no se necesita ninguna acción adicional.
- Para productos etiquetados como AI por suscripción, debe suscribirse en [my.birdfy.com](https://my.birdfy.com) para acceder a esta función.

## **Identification des oiseaux**

- Pour les produits étiquetés AI gratuite à vie, la fonction d'identification des oiseaux est incluse et activée automatiquement, aucune action supplémentaire n'est requise.
- Pour les produits étiquetés AI par abonnement, vous devez vous abonner sur [my.birdfy.com](https://my.birdfy.com) pour accéder à cette fonction.

# Assembly

1

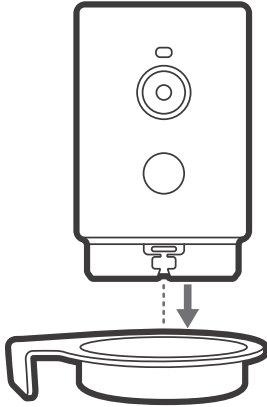

1. Insert the camera into the mount.

1. Inserta la cámara en el soporte.

1. Insérez la caméra dans le support.

2

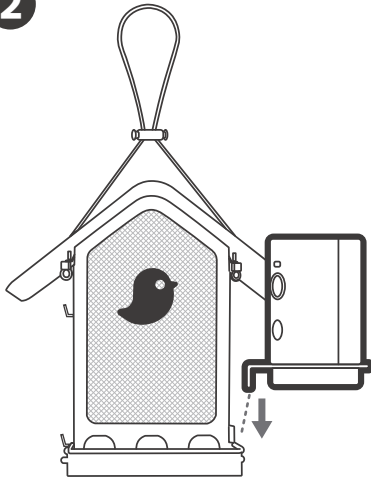

2. Hang it on the side of the feeder

2. Cuélgalo en el lateral del comedero.

2. Suspendez-le sur le côté de la mangeoire.

3

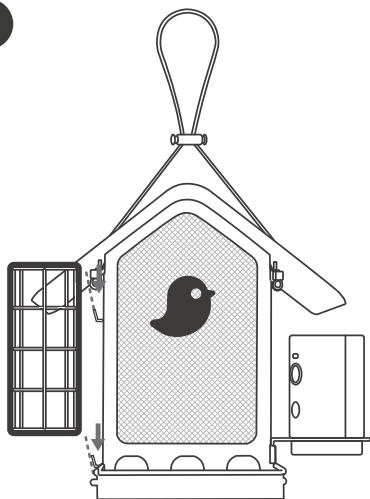

- 3. Hang the suet cage.
- 3. Cuelga la jaula de sebo.
- 3. Accrochez la cage à suif.

4

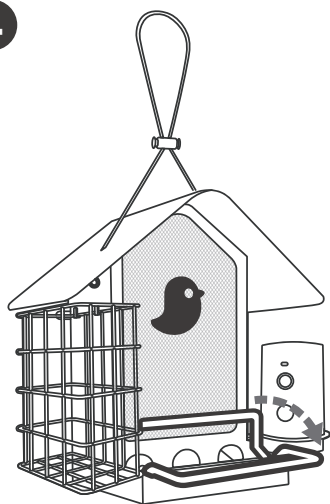

- 4. Unfold the perch.
- 4. Despliega el posadero.
- 4. Dépliez le perchoir.

# Outdoor Installation

- 1** Hang the feeder.  
Cuélgalo el comedero.  
Suspendez la mangeoire.
- 2** Adjust the cord lock to balance the feeder.  
Ajusta el bloqueo de cable para equilibrar el comedero.  
Ajustez le verrou du câble pour équilibrer la mangeoire.

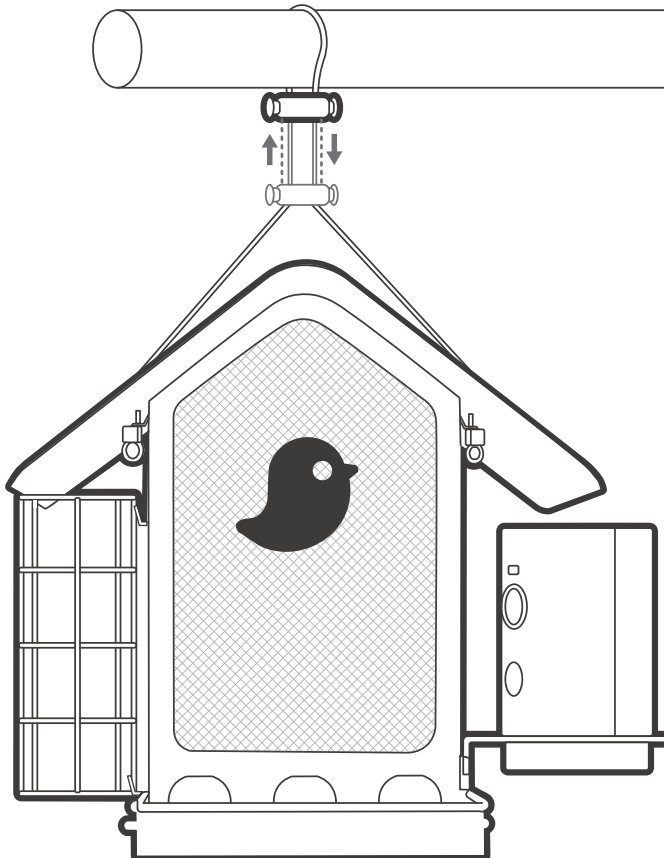

# Adding Birdseed

1

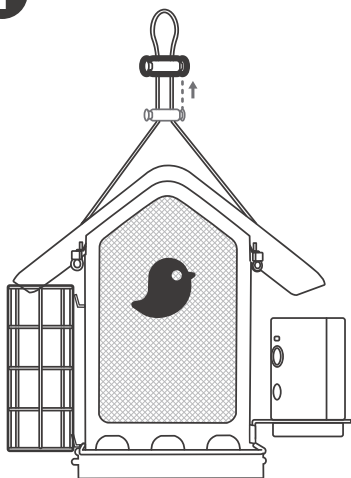

1. Slide the cord lock toward the far end of the hanging cable.
1. Desliza el bloqueo de cable hacia el extremo del cable de suspensión.
1. Faites glisser le verrou du câble vers l'extrémité du câble de suspension.

2

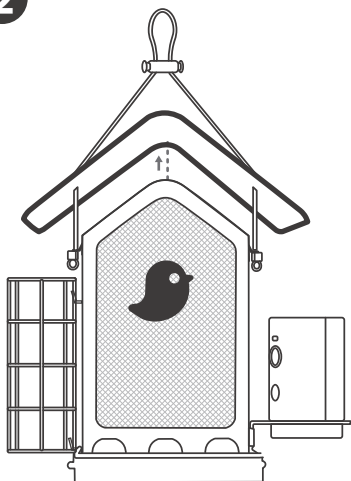

2. Lift up the roof.
2. Levanta el techo.
2. Soulevez le toit.

3

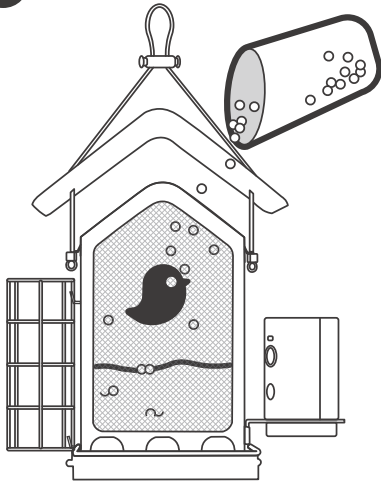

- 3. Add bird feed.
- 3. Agrega alimento para aves.
- 3. Ajoutez de la nourriture pour oiseaux.

4



- 4. Put the roof back.
- 4. Vuelve a colocar el techo.
- 4. Remplacez le toit.

# Adding Suet Cake

1

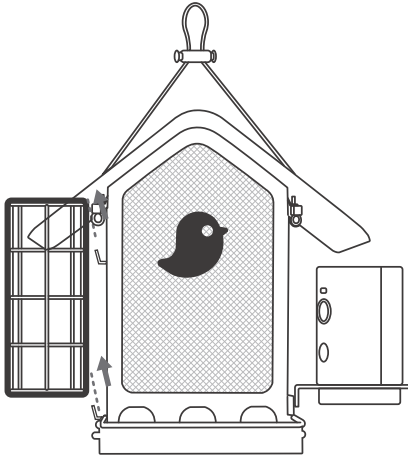

1. Lift the suet cage upward to remove it.
1. Levanta la jaula de sebo hacia arriba para retirarla.
1. Soulevez la cage à suif pour l'enlever.

2

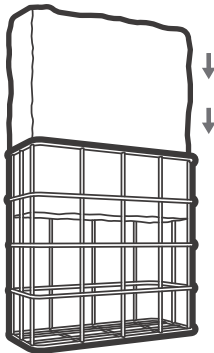

2. Put in the suet cake.
2. Coloca el pastel de sebo.
2. Mettez le gâteau de suif.

3

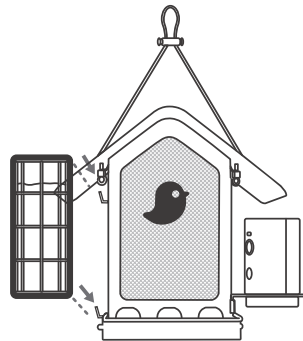

3. Put the suet cage back.
3. Vuelve a poner la jaula de sebo.
3. Remplacez la cage à suif.

# Cleaning

1

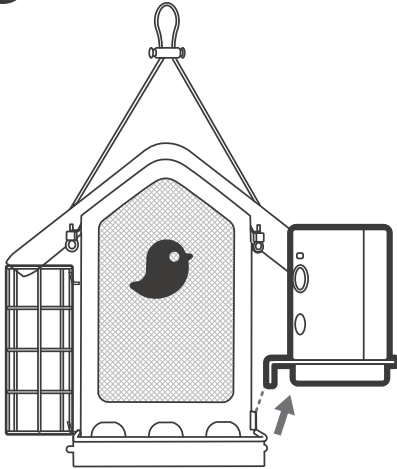

1. Remove the camera and camera mount as a whole.
1. Retira la cámara y el soporte de cámara en su totalidad.
1. Retirez la caméra et le support de caméra dans son ensemble.

2

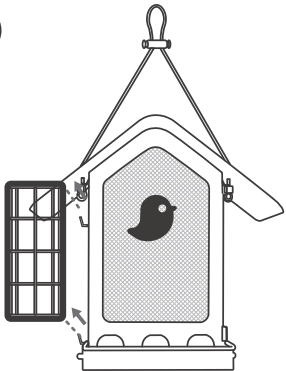

2. Take out the suet cage.
2. Saca la jaula de sebo.
2. Sortez la cage à suif.

3

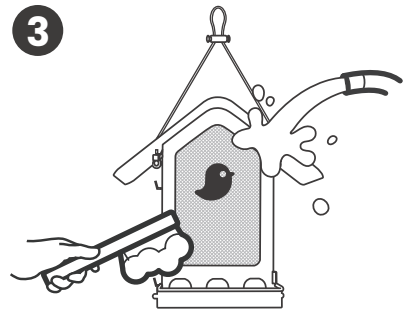

3. Use water and a brush to clean.
3. Usa agua y un cepillo para limpiar.
3. Utilisez de l'eau et une brosse pour nettoyer.

# Support

We are dedicated to offering top-notch products and services to our customers. Should you encounter any issues with your Birdfy, please don't hesitate to reach out to us.

- Email: [support@birdfy.com](mailto:support@birdfy.com)
- Phone: 1(866)749-0567 (7am-7pm, PTZ)
- In-App Live Chat

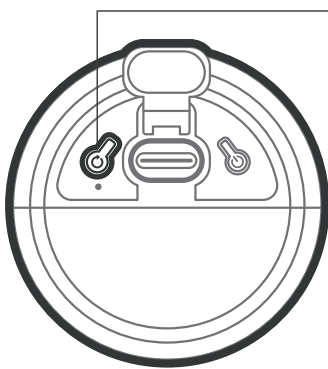

Reboot button

Botón de reinicio

Bouton de redémarrage

## **If your Birdfy camera goes offline or fails to stream, try these troubleshooting steps:**

1. Ensure the camera is fully charged.
2. Verify your home Wi-Fi connectivity. Try to reconnect the camera to your Wi-Fi network.

## **If the issue persists:**

1. Disconnect the camera from the solar panel or charger.
2. Press the reboot button to power down the camera

entirely.

3. Press and hold the power button for 3 seconds to restart the camera.

Nos dedicamos a ofrecer productos y servicios de primera calidad a nuestros clientes. Si tiene algún problema con su Birdfy, no dude en contactarnos.

- Correo electrónico: [support@birdfy.com](mailto:support@birdfy.com)
- Teléfono: 1(866)749-0567 (7am-7pm, PTZ)
- Chat en vivo en la aplicación

### **Si tu cámara Birdfy se desconecta o no puede transmitir, prueba estos pasos de resolución de problemas:**

1. Asegúrate de que la cámara esté completamente cargada.
2. Verifica la conectividad de tu red Wi-Fi doméstica. Intenta reconectar la cámara a tu red Wi-Fi.

### **Si el problema persiste:**

1. Desconecta la cámara del panel solar o del cargador.
2. Presione el botón de reinicio durante 1 segundo para apagar completamente la cámara.
3. Mantén presionado el botón de encendido durante 3 segundos para reiniciar la cámara.

Nous nous engageons à offrir des produits et services de qualité supérieure à nos clients. Si vous rencontrez des problèmes avec votre Birdfy, n'hésitez pas à nous contacter.

- E-mail : [support@birdfy.com](mailto:support@birdfy.com)
- Téléphone : 1(866)749-0567 (7h-19h, PTZ)
- Chat en direct dans l'application

**Si votre caméra Birdfy se déconnecte ou ne parvient pas à diffuser, suivez ces étapes de dépannage :**

1. Assurez-vous que la caméra est complètement chargée.
2. Vérifiez la connectivité de votre réseau Wi-Fi domestique.  
Essayez de reconnecter la caméra à votre réseau Wi-Fi.

**Si le problème persiste :**

1. Débranchez la caméra du panneau solaire ou du chargeur.
2. Appuyez sur le bouton de redémarrage pendant 1 seconde pour éteindre complètement la caméra.
3. Maintenez le bouton d'alimentation enfoncé pendant 3 secondes pour redémarrer la caméra.



**Birdfy Help Center**

# The Birdfy Community

Scan the QR code to join our vibrant Facebook community and connect with fellow bird enthusiasts! Discover valuable insights on birdwatching and bird feeding techniques, exchange your finest Birdfy captures, and witness exotic birds from around the world!

Escanee el código QR para unirse a nuestra vibrante comunidad de Facebook y conectarse con otros entusiastas de las aves. Descubra información valiosa sobre observación de aves y técnicas de alimentación, intercambie sus mejores capturas de Birdfy y observe aves exóticas de todo el mundo.

Scannez le code QR pour rejoindre notre communauté Facebook dynamique et vous connecter avec d'autres passionnés d'oiseaux ! Découvrez des informations précieuses sur l'observation des oiseaux et les techniques d'alimentation, partagez vos meilleures captures Birdfy et contemplez des oiseaux exotiques du monde entier !



Birdfy FB Community

Join our community!



@birdfy by netvue

# Warning

## **FCC Statement**

Note: This equipment has been tested and found to comply with the limits for a Class B digital device, pursuant to part 15 of the FCC Rules. These limits are designed to provide reasonable protection against harmful interference in a residential installation. This equipment generates, uses and can radiate radio frequency energy and, if not installed and used in accordance with the instructions, may cause harmful interference to radio communications. However, there is no guarantee that interference will not occur in a particular installation. If this equipment does cause harmful interference to radio or television reception, which can be determined by turning the equipment off and on, the user is encouraged to try to correct the interference by one or more of the following measures:

- Reorient or relocate the receiving antenna.
- Increase the separation between the equipment and receiver.
- Connect the equipment into an outlet on a circuit different from that to which the receiver is connected.
- Consult the dealer or an experienced radio/TV technician for help.

This device complies with part 15 of the FCC Rules. Operation is subject to the following two conditions:  
(1) This device may not cause harmful interference, and  
(2) this device must accept any interference received, including interference that may cause undesired operation.

Any changes or modifications made without explicit approval from the responsible party in compliance may

result in the user being unauthorized to operate the device.

This device meets the FCC radiation exposure limits for uncontrolled environments. To ensure safe installation and operation, maintain a minimum distance of 20cm between the radiator and your body.

FCC ID: 2BC96NB-CMA01

### **CE Statement**

The information provided on the packaging is allowed to identify geographical areas within the member states where restrictions on use or requirements for authorized use exist, if applicable.

The structure of the product allows it to be used in at least one member state without violating applicable requirements for the use of radio spectrum.

Manufacturer information:

NETVUE INC.

1055 East Colorado Boulevard 5th Floor

Pasadena, CA, 91106

### **IC Statement**

This device contains licence-exempt transmitter(s)/ receiver(s) that comply with Innovation, Science and Economic Development Canada's licence-exempt RSS(s). Operation is subject to the following two Economic Development Canada's licence-exempt RSS(s). Operation is subject to the following two conditions:

1. This device may not cause interference.
2. This device must accept any interference, including

interference that may cause undesired operation of the device.

L'émetteur/récepteur exempt de licence contenu dans le présent appareil est conforme aux CNR d'Innovation, Sciences et Développement économique Canada applicables aux appareils radio exempts de licence. L'exploitation est autorisée aux deux conditions suivantes:

3. L'appareil ne doit pas produire de brouillage;
4. L'appareil doit accepter tout brouillage radioélectrique subi, même si le brouillage est susceptible d'en compromettre le fonctionnement.

This equipment complies with IC radiation exposure limits set forth for an uncontrolled environment. This transmitter must not be co-located or operating in conjunction with any other antenna or transmitter. This equipment should be installed and operated with a minimum distance of 20cm between the radiator and your body.

Cet équipement respecte les limites d'exposition au rayonnement IC établies pour un environnement non contrôlé.

Cet émetteur ne doit pas être localisé ou fonctionner en conjonction avec une autre antenne ou un autre émetteur. Cet équipement doit être installé et utilisé à une distance minimale de 20cm entre le radiateur et votre corps.



1. Contains batteries, keep away from fire.
2. Battery withstandable use/storage/transport temperature: 14–113°F (-10–45°C).
3. Replacing the battery with an incorrect type may cause a safety hazard.
4. Disposing of battery in fire/oven, or crushing/cutting it, may cause explosion.

1. Contiene baterías, mantener alejado del fuego.
2. Temperatura soportada por la batería para uso, almacenamiento o transporte: 14–113°F (-10–45°C).
3. Reemplazar la batería con un tipo incorrecto puede representar un riesgo de seguridad.
4. Desechar la batería en fuego/horno o aplastarla/cortarla puede causar una explosión.

1. Contient des piles, tenir à l'écart du feu.
2. Température supportée par la batterie en utilisation, stockage ou transport : -10–45°C (14–113°F).
3. Remplacer la batterie par un type incorrect peut présenter un danger pour la sécurité.
4. Jeter la batterie au feu/au four ou l'écraser/la couper peut provoquer une explosion.

Icamera International Trading Co., Ltd  
Unit G25 Waterfront Studios  
1 Dock Road, London, United Kingdom  
support@birdfy.com

UK	REP
----	-----

eVatmaster Consulting GmbH  
Raiffeisen Street 2B11, 63110,  
Rodgau, Hessen, Germany  
support@birdfy.com

EU	REP
----	-----

NETVUE INC.  
1055 East Colorado Boulevard,  
5th Floor, Pasadena, CA, 91106  
+1(866)749-0567  
support@birdfy.com

US	REP
----	-----

Brand: Birdfy  
Product Name: Birdfy Feeder Metal V  
Model: NB-FM003

Camera Name: Birdfy Cam BA3A  
Camera Model: NB-CMA01  
FCC ID: 2BC96NB-CMA01  
IC: 31482-NBCMA01

Manufacturer: NETVUE INC.  
1055 East Colorado Boulevard 5th Floor,  
Pasadena, CA, 91106  
+1 (866) 749-0567  
support@birdfy.com  
Made in China  
Designed in USA



Raccolta Carta

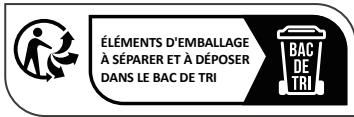



## Contact us:

---



[support@birdfy.com](mailto:support@birdfy.com)



In-App Chat



1(866)749-0567  
7am-7pm, PTZ

[www.birdfy.com](http://www.birdfy.com)  
© Netvue Inc.