

CG304P/S



FEATURES

- Dual-stacked burners go from 18,000 Btu down to a mere breath of flame
- Lower tier of dual-stacked burner lets you simmer and melt
- Continuous cast-iron grates for easy movement of pots and pans
- Easy-clean seamless burner pan
- Rigorously tested in our U.S. manufacturing facilities for decades of use
- Exceptional 24/7 support from our Customer Care team in Madison
- Spark ignition system re-ignites if flame goes out
- Signature red control knobs (black or stainless also available)

ACCESSORIES

- Signature red, black or brushed stainless control knobs
- Center burner wok grate
- High altitude conversion kit

Accessories available through an authorized Sub-Zero dealer.
For local dealer information, visit subzero-wolf.com/locator.



KNOB OPTIONS



COOKTOP SPECIFICATIONS

- 2 - 9,200 Btu Burner
- 1 - 12,000 Btu Burner
- 1 - 18,000 Btu Burner

PRODUCT SPECIFICATIONS

Model	CG304P/S
Dimensions	30"W x 4"H x 21"D
Weight	50 lbs
Electrical Supply	120 VAC, 60 Hz
Electrical Service	15 amp dedicated circuit
Gas Supply	3/4" ID line
Gas Inlet	1/2" NPT female

ELECTRICAL

GAS

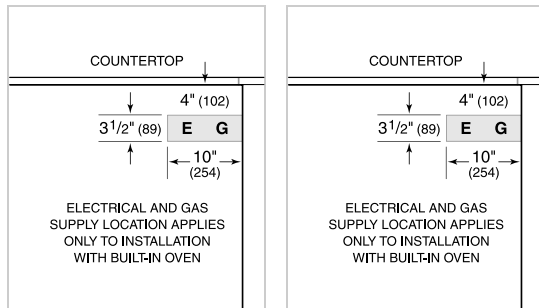

NOTE:

Dimensions in parenthesis are in millimeters unless otherwise specified

DIMENSIONS

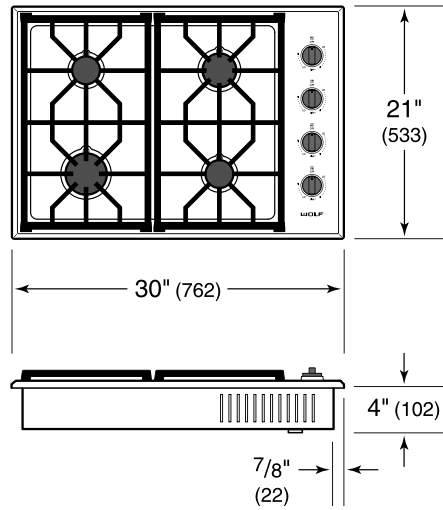

STANDARD INSTALLATION

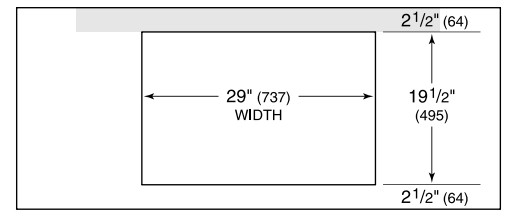

COUNTERTOP CUT-OUT

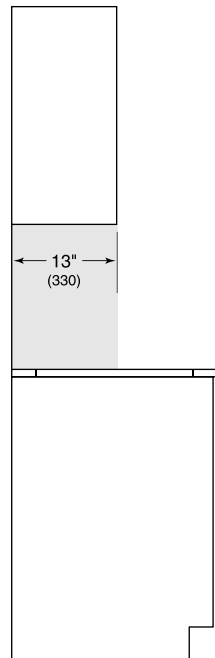

SIDE VIEW

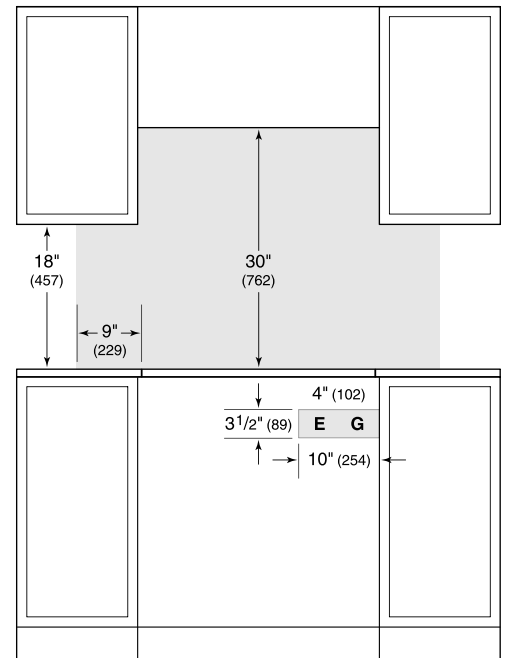

FRONT VIEW

NOTE: Shaded area above countertop indicates minimum clearance to combustible surfaces, combustible materials cannot be located within this area. Electrical and gas supply location only applies to installations with built-in oven.