

YCR-M05

User Guide

Robotic Vacuum Cleaner eX500

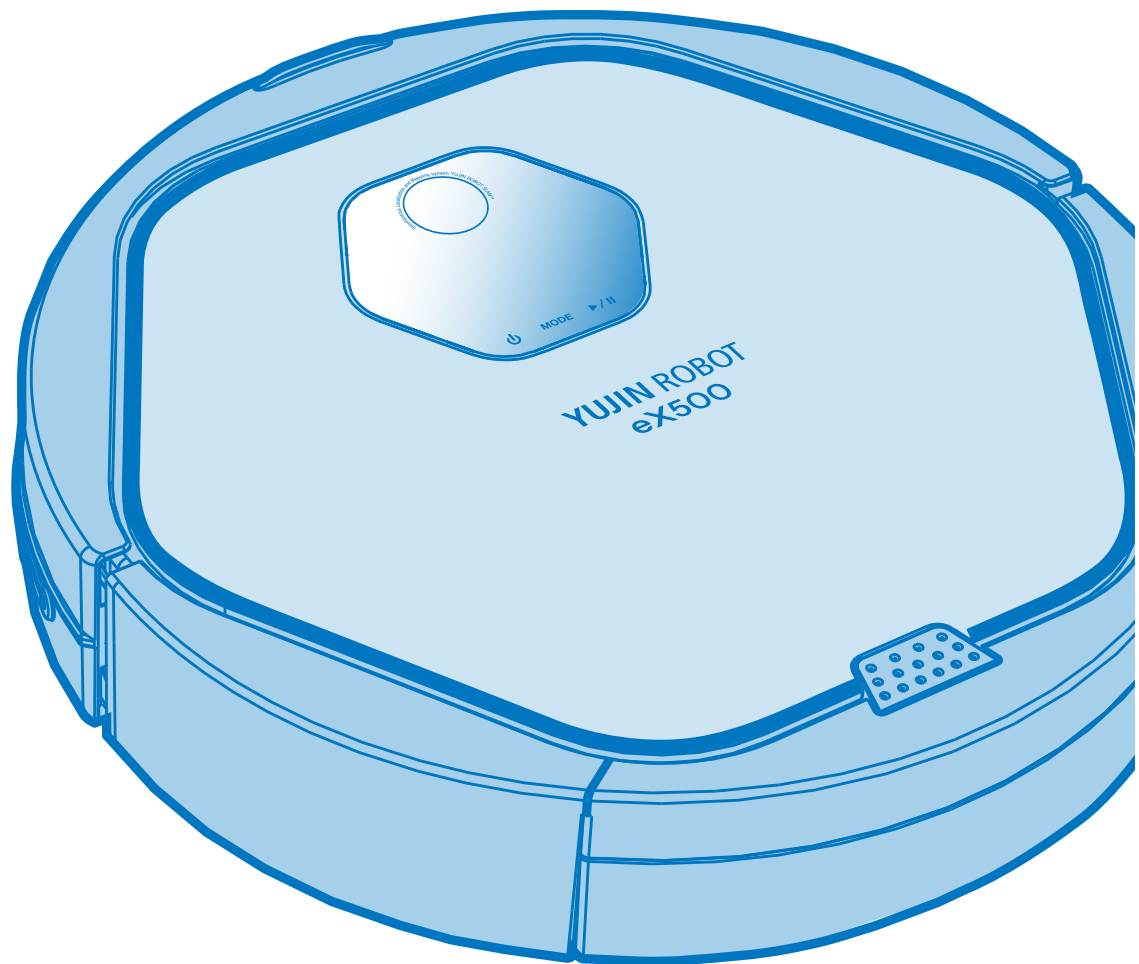

■ Please be sure to read the Safety Precautions before use.

www.yujinrobotusa.com

Safety precautions	-----	2
Components	-----	5
Reference	Tips for effective cleaning -----	7
	Operating principles of eX500	
Installing eX500	pre-operation check list -----	8
	• Assemble side-brushes	
	• Insert remote control batteries	
	• Assemble Ultra Microfiber Mop	
	Pre-cleaning check list -----	9
	• Install Base(Charging) Station	
	• Charging	
	• Set Current Time	
	• Install boundary area tape	
Using eX500	Using eX500 -----	10
	• Power On/Off	
	• Start / Stop cleaning	
	• Using the move and charge functions	
	Cleaning mode -----	12
	Set cleaning time	
eX500 care & maintenance	Emptying the Dust Bin and cleaning the Antibacterial Filter ----	13
	Cleaning the Side Brushes	
	Cleaning the Sensors	
	Cleaning the Main Brush	
	Cleaning the Front Wheel	
Storage	-----	15
Troubleshooting	-----	16
Error codes	-----	17

Please read this manual carefully and follow all warnings and instructions.



Prohibited

Users must be aware of operations prohibited by this product.



Warning

Users must follow the instructions to avoid serious injury or death.



Caution

Users must follow the instructions to avoid injury or product damage.

Electric and power cord precautions



Warning

- Do not wrap the power cord tightly or place heavy objects on it.
 - This may cause electric shock or fire.
- Keep the pin and interface of the power plug clean from dust or water.
 - This may cause malfunction or electric shock.
- Do not pull the power cord or touch the power plug with wet hands.
 - This may cause electric shock or fire.
- Do not use a damaged power plug or power cord, or insert the power plug into a loose outlet.
 - This may cause electric shock or fire.
- In the event water enters the internal part of the cleaner, the product should be sent for service even though the product was dried.
- Do not repeatedly plug and unplug the product.
 - This may cause electric shock or fire.
- Caution should be taken when plugging the adapter directly into the charging socket.
 - This may cause electric shock or fire.

Precautions before using



Prohibited

- Do not touch the charger's power cord with wet hands.
→ This may cause electric shock.



Warning

- Arrange cables or wires in the cleaning area before use to avoid entangling with the robot.
→ This may cause fire or electric shock due to damaged cable.



Caution

- Remove light objects or clothing from the cleaning area before use.
→ This may damage the object or clothing while robot is in use.



Caution

- Remove small or fragile objects from the cleaning area before use.
→ Fragile objects may be damaged.
→ Remove coins or expensive jewelries before cleaning.



Caution

- Clear the floor of objects that may get in the way.
→ Thin towels, pads, power cords, table clothes, etc., may get tangled with the wheels.
Also objects on a table may fall off if the robot bumps a table.



Caution

- Empty the dust bin before operating eX500.
→ Suction function may not perform well if dust bin is full.



Caution

- Check that the main components such as antibacterial filter, brush and dust bin are assembled properly before cleaning.
→ In the event you use eX500 without the main components, such as the antibacterial filter or brush, the product will not clean properly, and such operation may damage the product. Also, children and pets may be deemed as a barrier by the eX500 resulting in certain areas not being cleaned.



Warning

- Do not operate eX500 when children or pets are present and left alone.
→ The children or pets may be attracted to eX500 and may hurt themselves attempting to play with the product.



Caution

- Do not place the power cord on the floor when installing a charging station.
→ eX500 may drag the power line while auto-charge or cleaning.



Warning

- Keep the charging station away from water.
→ This may cause electric shock or fire.

Precautions while using



Warning

- In the event of an unusual sound, smell or smoke emanating from the product, immediately turn off eX500 and place it in a safe distance away from anything flammable.

→ This may cause electric shock or fire.



Caution

- Do not use eX500 on a table or any high surface.

→ This may damage the product.



Caution

- In rare instances eX500 cleaner may scratch or otherwise damage particular flooring. In this event, discontinue use.



Caution

- In the event a large piece of plastic or other substance is vacuumed up, remove it immediately.

→ Serious damage to the eX500 can occur when it is used for a period of time with its suction duct clogged.



Caution

- Transport eX500 to another area when it is blocked by a threshold of the entrance or ledge .



Caution

- Prevent eX500 from vacuuming liquid materials.

- Do not use eX500 near flammables such as cigarettes, hot materials or gasoline.

→ This may cause fire.



Caution

- Do not use use eX500 outdoors.

Precautions after using



Warning

- In the event a foreign substance is stuck to the sensor, eX500 may malfunction.



Warning

- Prior to cleaning off foreign substances, turn OFF the power switch and then use the provided cleaning brush to remove.

→ If eX500 operates all of the sudden, it may cause serious damage to the product.



Warning

- In the event eX500 or components are destroyed, contact the manufacturer or service center for repair.

→ This may cause electric shock or fire.



Warning

- Prior to cleaning the charging station, first pull out the power plug for safety reasons.



Warning

- Mishandling of the battery may cause an explosion or fire. At the end of the battery's service life, dispose the battery in a lawful manner.

→ This may cause fire.



Caution

- Do not spray water directly on the product or wipe eX500 with volatile materials such as benzene, thinner or alcohol when cleaning the product.



Caution

- Do not apply undue pressure to the bumper.

→ In case the bumper sensor is damaged, this may crash on the wall or with furniture.



Caution

- Do not disassemble, repair or alter the product except an authorized service provider.

→ This may damage the product.

Components

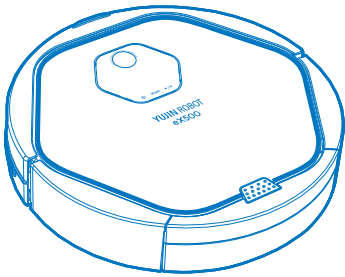

Robot Cleaner

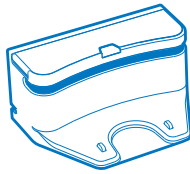

Charging Station

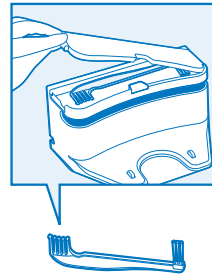

Cleaning Brush
(Cleaning Brush is inside of the charging station)

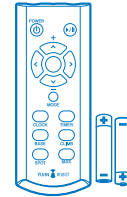

Remote Control
(Batteries included)

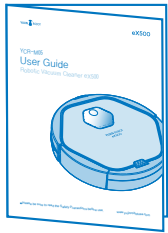

User Guide

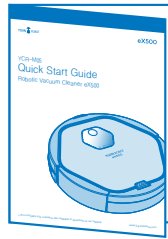

Quick Guide

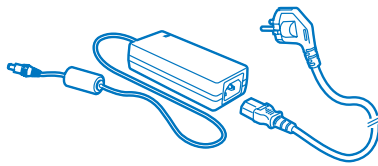

Adapter

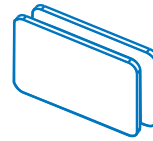

Antibacterial Filter

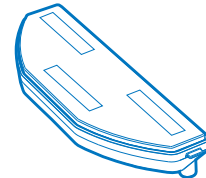

Mop Plate

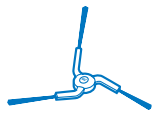

Side-Brush(R)

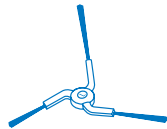

Side-Brush(L)

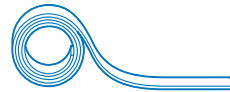

Boundary Area Tape
(Virtual Wall)

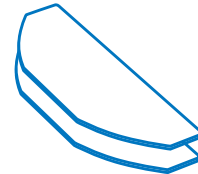

Ultra Microfiber Wet Mop

Part Listing

● Top

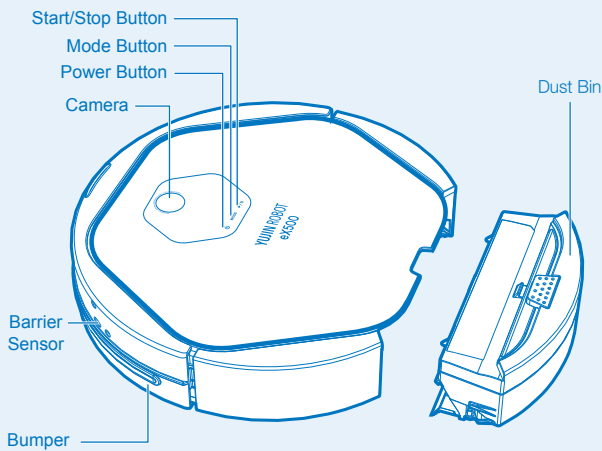

● Bottom

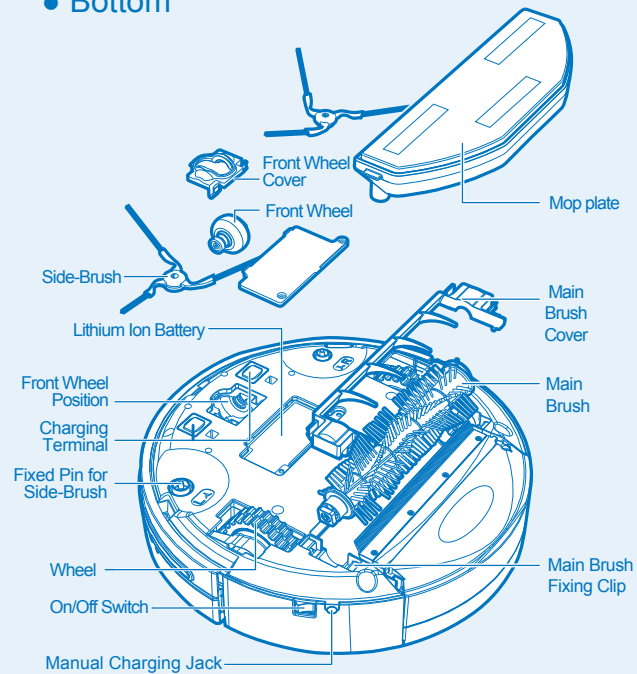

● Charging Station

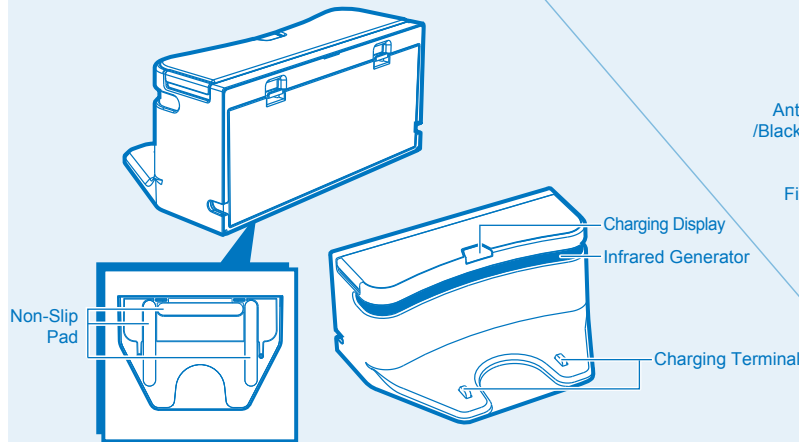

● Dust Bin

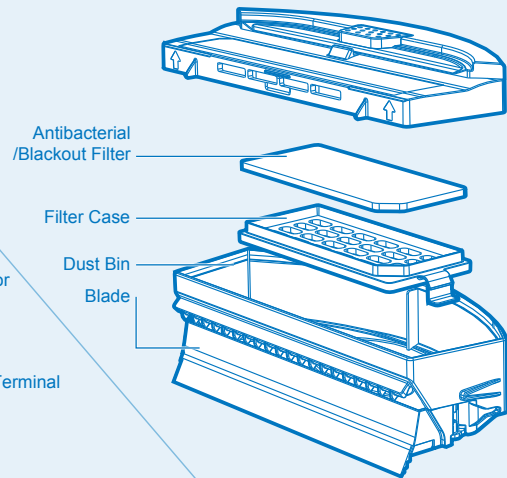

● Remote Control

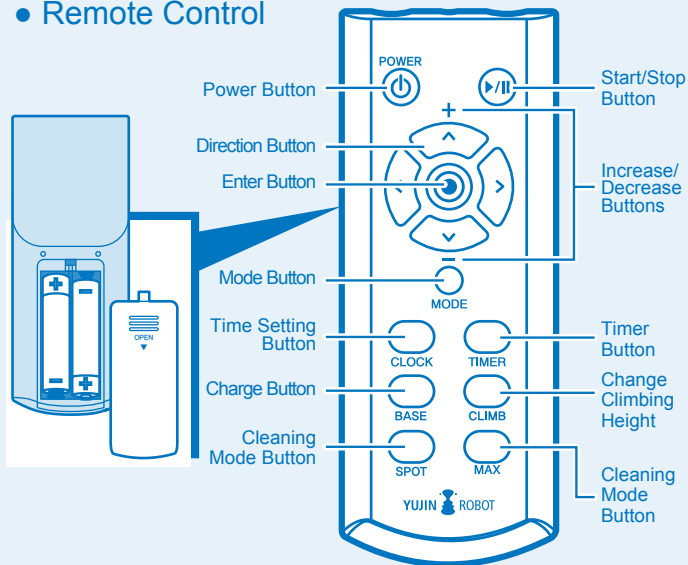

● Display Screen

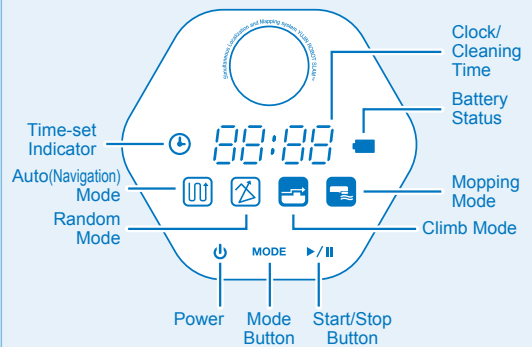

Remote Control

1. Press the Power on the Remote Control.
2. Press the Start/Stop (▶/||) Button on the Remote Control.
3. Press the Power Button to stop the operation.
4. To change modes, press the Power Button, and use the Mode Button to select the desired cleaning method, and then press the Start/Stop (▶/||) button.
5. The default mode is Auto + Climb.
6. Max Mode & Spot Mode

The Max Mode allows eX500 to clean until its battery is depleted. In Max Mode, eX500 starts in Auto(Mapping) mode to perform overall cleaning. When finished cleaning, it changes to Random Mode for additional cleaning. (Cleaning will last approximately 120 minutes.)

※ On the floors like carpet, rug, patterned tiles and marble, set the iClebo to Climb Mode for cleaning.

Tips for effective cleaning

Please follow the instructions below for high cleaning efficiency.

- Remove and empty eX500's dust bin after each use.
- Use the Area Boundary Tape to confine eX500 to a particular room or area, and prevent it from getting too close to electrical cords, computer cords, or delicate objects on the floor, etc.
(Refer to P.10 Install Boundary Area Tape)
- Remove all the non-fixed objects such as toys, magazines or shoes from the cleaning area before cleaning.
- Do not lift up or move eX500 manually while operating.
(If you do this, the robot loses its way and skips areas.)
- Make sure to charge for at least 1 hour before using eX500 for the first time. (Refer to P.9 Charging)

Operating principles of eX500

Principles of the Robotic Vacuum Cleaner

This product recognizes the ceiling and obstacles with the camera and various sensors, and cleans by making a virtual map in the CPU installed in the main body. It operates by drawing the most efficient map by determining the area that has been cleaned and the area to clean. (Camera navigation is disabled in random mode.) With about 20 detection sensors, eX500 can avoid wall or objects. (chair, vase, etc)

It climbs over an obstacle up to 0.79 inches in height, and floor sensors help it to avoid falling down stairs. Be careful that pets or children do not force the robot to fall by playing with it.

How it works

This product has one main brush, two side brushes and vacuum motor. Debris on the floor is gathered by the rotating side brushes, and is swept into the dust bin by the rotating main brush.

Pre-operation check list

Assemble side-brushes

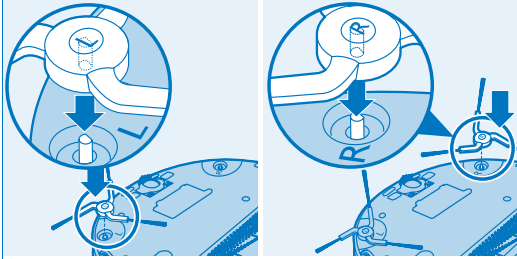

1. After turning over eX500, identify the position of the left and right side brushes.
2. Match the L side brush to the L marked on the bottom of eX500. Then match the groove on the fixed pin and the side brush and press on firmly.
3. Match the R side brush to the R marked on the bottom of eX500. Then match the groove on the fixed pin and the side brush and press on firmly.

CAUTION

Fit the side brush into the fixed pin of the robotic vacuum cleaner matching the same shape.



Insert remote control batteries



Install 2 x AAA batteries before using the Remote Control.

1. Push the cover of the backside of the Remote Control downward to open.
2. Check (+)(-) of the batteries and install.
3. Match the cover to the groove, and close until “click” sounds.

Assemble Ultra Microfiber Mop

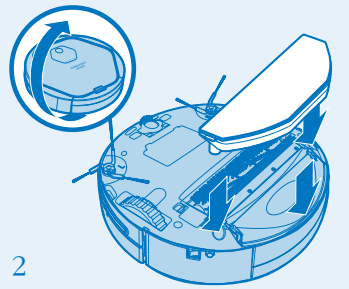
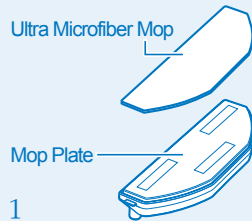

1. Turn over eX500, and install the Mop Plate by attaching it to the bottom of eX500 over the Dust Bin.
2. If Mopping mode is not used, keep the Mop Plate separate from eX500.

- ❖ In Mopping mode with mop plate attached, there may be cases that it is blocked by carpet, rug, or doorsill, and cannot go forward normally. In such cases, moving the rug or carpet to one side and using Mopping mode is recommended.
- ❖ In some floor environments, there may be cases of not being able to go forward normally. If it cannot go forward normally in the floor environment of marble floor or certain patterns, then also set Climb mode for cleaning.

Pre-cleaning check list

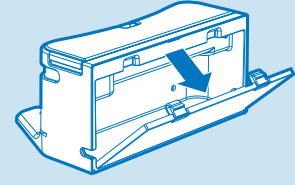
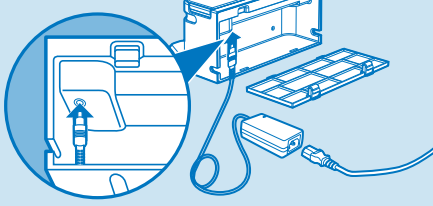
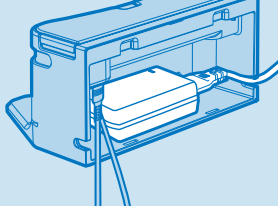
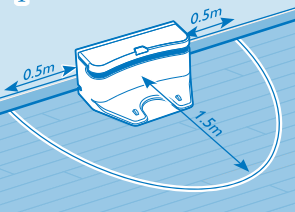
Install Base (Charging) Station	1		2		3	
	4		<ol style="list-style-type: none"> 1. Open the back cover of the Charging Station, and install the adapter with connected power plug as shown in the figure 2 above. 2. Completely connect the charging jack of the adapter to the jack inside the charging station. 			

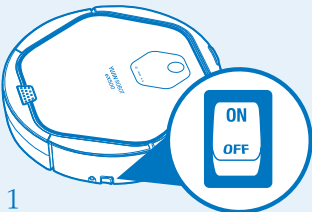
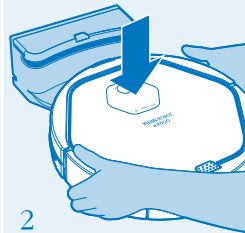
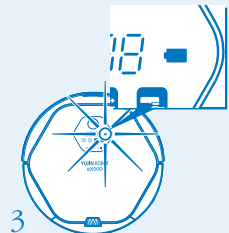
Charging	The battery is not charged at the time of product purchase, so it must be fully charged before first use.	
	  	<p>※ Battery Indicator Color</p> <ul style="list-style-type: none"> - Green: Battery is fully charged - Yellow: Remaining battery is 50% or less - Red: Remaining battery is 20% or less
<ol style="list-style-type: none"> 1. Turn on the Power Switch on the side of the product. 2. Correctly match the Charging Pin on the bottom of the Main Body to the socket of the Charging Station, and start the charging. <ul style="list-style-type: none"> >> The battery status in the display window blinks and charging starts. If battery is completely discharged, "Lo" is displayed in the display window. 3. Red, Yellow and Green light will be blinking in order on the display window according to the battery's charge while the robot is charging and the battery indicator will become steady green when the battery is full. 		
<p>[Auto-charge during use]</p> <ul style="list-style-type: none"> ※ When the battery is low during an operation, this product moves to the charging station and performs auto charging. After the charging is completed, it finishes cleaning the remaining space, and returns to the charging station. ※ When the battery is low, this product is set to return to the starting place of the cleaning. So if it started from a place other than the charging station, it returns to the place near the starting place of the cleaning. ※ Charging indicator color on Charging Station <ul style="list-style-type: none"> - Red: change to eX500 is in operation away from the charging station, or the connection between eX500 and the charging station is improperly connected. - Green Blinking: Recharging - Green: Recharge completed 		

Set Current Time

※ Make sure to set the current time for the set cleaning time.

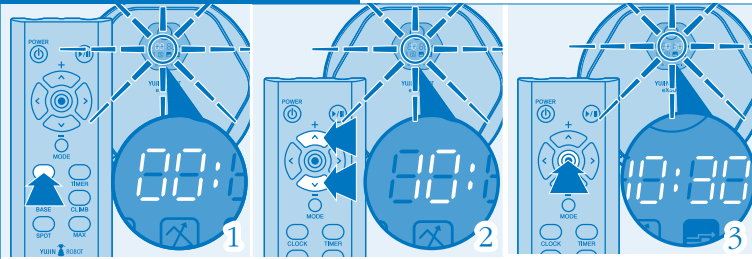

1. Press the Clock button on the remote control. The time on the display screen will flash.
2. Set the "hour" with the (+)(-) buttons on the remote control, and press the Enter button.

3. Set the "minute" with the (+)(-) buttons on the remote control, and press the Enter button.
4. When the time is set, it confirms the setting with beep sound.

Install boundary area tape

※ Place the tape on the floor to prevent the robot from entering an undesired area.

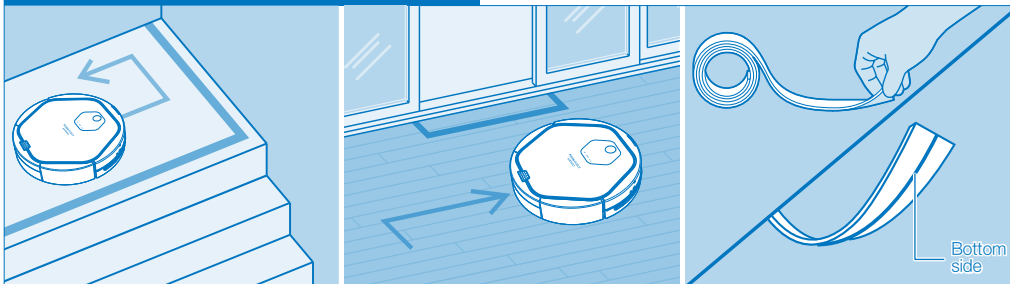

Attach the tape at the top of stairs where there is a danger of falling.

→ If dust accumulates on the fall prevention sensors they may not "see downwards" and the robot may fall.

Using eX500

Power On / Off

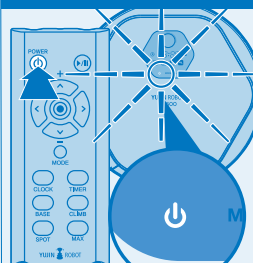

Press the Power Button (⏻).
If you press it one more time,
it is turned off.

Start / Stop cleaning

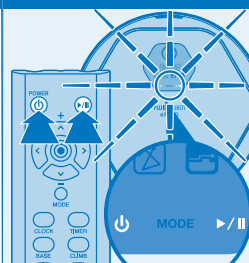

**Intelligent Cleaning
: AUTO+ CLIMB**

1. Press the Power Button (⏻).
※ Make sure the AUTO and CLIMB icons light up on the display window.
2. Press the Start Button (▶/||).

※ You can press the Climb Button on the remote control to cancel Climb Mode. (If CLIMB mode is off, the robot does not go over doorsills or climb onto the carpet or rugs over 0.2 in. in height.)

※ During an intelligent cleaning, the robot performs the cleaning in vision mapping method. When the robot decides that the cleaning is finished, it returns to the starting point.

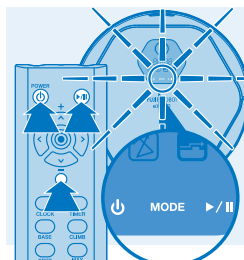

Selected Cleaning
: **RANDOM, SPOT** (blinking), **MAX, Wet Mop**

A. RANDOM mode

It cleans with a random method for the time set by the user.

1. Press the power button
2. Press the MODE button to select RANDOM.
3. Set the cleaning time for robot in the display window. (Default is 60 min. Adjust the time with +, - on remote control.)
4. Make sure RANDOM icon lights up on the display window.
5. Press the START button.

B. SPOT mode

It uses AUTO mode to perform focused cleaning within a range of 1.6 m² on a zigzag pattern.

1. Press the POWER button.
2. Press the SPOT button on the remote control.
3. Make sure the AUTO icon is blinking on the display window.
4. Press the START button.
 - When the robot has completed SPOT cleaning mode, it will return to its starting point.

C. MAX mode

In MAX mode, eX500 will first clean in AUTO mode. When the AUTO cleaning is finished, eX500 will clean in RANDOM mode until the battery is low.

1. Press the POWER button.
2. Press the MAX button on the remote control.
3. Make sure both the AUTO and RANDOM icons lights up on in the display window.
4. Press the START
 - The robot cleans until the battery runs out, and returns to the starting point.

D. WET MOP mode

1. Attach the mop plate with mop pad to the robot.
2. Make sure the MOP icon lights up on the display window. Deselecting CLIMB is recommended.

3. Use the MODE button to select AUTO or RANDOM.

※ Spot mode and Max mode can only be selected by the remote control.

※ In all mode selections, CLIMB is on by default. If you want to turn it off, press the CLIMB button on the remote control to turn off CLIMB mode. (If you turn off CLIMB mode, the robot will not go over doorills or climb on to a carpet.)

Using the move & charge functions

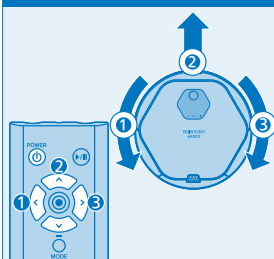

1. Use the direction buttons of remote control to send eX500 to specific area.

- When the backward button is pressed, eX500 will turn 180 degrees to change directions.
- If the direction button is pressed right after pressing power button, it moves without cleaning (suction).

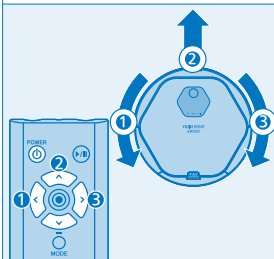

2. After eX500 has started cleaning, if a direction button is pressed, it will move in the desired direction while cleaning.

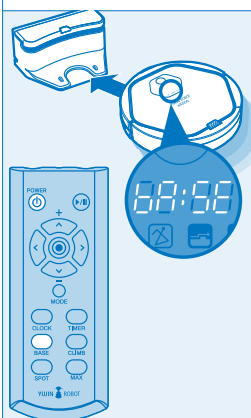





3. If the charging (BASE) button of the remote control is pressed, it finds and moves to the charging station and starts charging.



BASE will be displayed on eX500 when the robot is returning to the charging station.

Cleaning mode



- ※ Climbing mode is on by default and eX500 will climb up a height of 0.79 inches.
- ※ To prevent eX500 from climbing onto taller objects press the CLIMB button. With climbing mode disabled the robot will only climb a height of 0.79 inches.

Set the mode	Cleaning mode	Explanation	Cleaning mode	Explanation
Remote control & display window	 AUTO	Cleans with camera navigated mapping	 RANDOM	Cleans in a random pattern for a set duration. Set the duration with the (+)(-) buttons on the remote control
Only with remote control	 SPOT	Zigzag part cleaning within a range of 1.6 m ²	 MAX	After completing an AUTO cleaning, eX500 will change to RANDOM mode and clean until the battery is low.

Status	Explanation	Status	Explanation
 Mopping	The cleaning mode is automatically changed to Mopping mode once the mop plate mounted on the bottom	 Door sill adjust	Enabling CLIMB mode will increase the performance of climbing mode from 0.20 inches to 0.79 inches. However, even with climbing mode the shape of a surface may prevent eX500 from climbing over an obstacle less than 0.79 inches in height.

- ※ During the cleaning of carpet or marble floor & patterned tile floors usage of AUTO + CLIMB mode is recommended.

Set Cleaning Time

- ※ When the TIMER is set for cleaning, the robot starts the cleaning at the set time everyday.

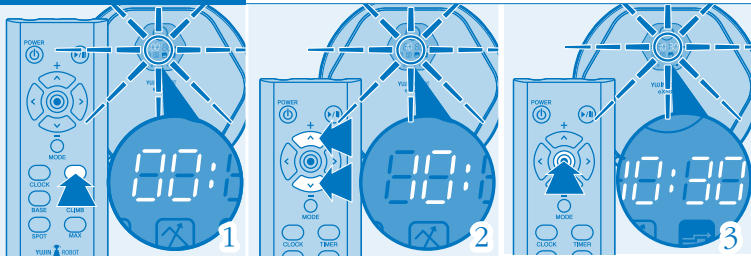

※ Refer to page 10 for setting the current time.

1. Press the TIMER button on the remote control.
 - The time indicator will blink in the display window.
 - If the cleaning time is set, it displays the set time.
 - At this time, to set a new cleaning time, press the TIMER button one more time.
2. Use (+)(-) to set the "hour" for the cleaning time and press the Enter button.
 - The set time is displayed in the display window.
3. Use (+)(-) to set the "minute" for the cleaning time and press the Enter button.
 - The set time is displayed in the display window, and the reservation icon (🕒) appears.
4. Once the time setting completes, select the cleaning mode and press Enter button.

- ※ To cancel the reservation, press the timer button on the remote control, and press the Enter button.
- ※ When a TIMER cleaning reservation is set in AUTO mode, the robot will start cleaning at the set time and return to the charging station when the cleaning is complete.
- ※ When a TIMER cleaning reservation is set in RANDOM mode, the robot will start cleaning at the set time for the set duration and then return to the charging station.

Emptying the Dust Bin and cleaning the Antibacterial Filter

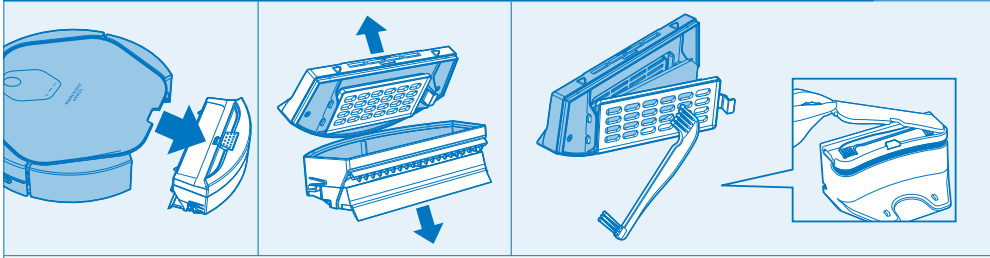

1. Hold the Dust Bin as in the figure and separate Antibacterial Filter Cover.
2. Clean the Filter using Cleaning Brush.

※ **Dust Bin can be washed with water.**
However, completely dry them before assembling and using them again.

Cleaning the Side Brushes

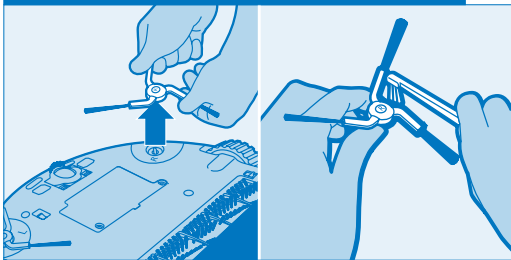

1. Separate the side brush with both hands.
2. Clean dust and foreign substances using the cleaning brush.

Cleaning the Sensors

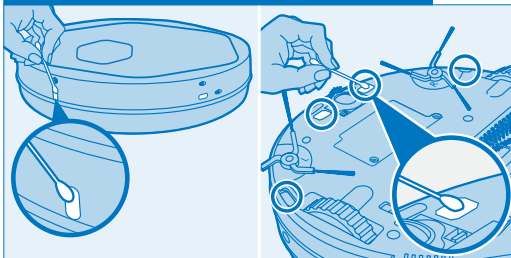

1. Wipe the sensors on the Front Bumper of eX500 using q-tips.
2. Wipe the sensors on the bottom of eX500 using q-tips.

Cleaning the Main Brush

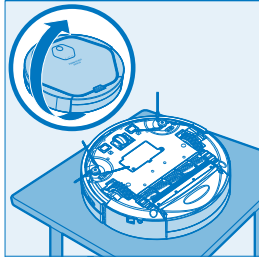
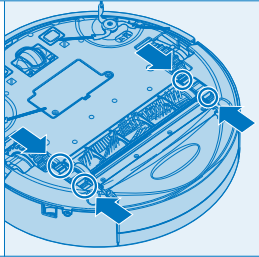
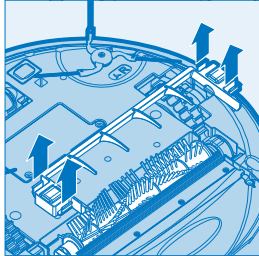
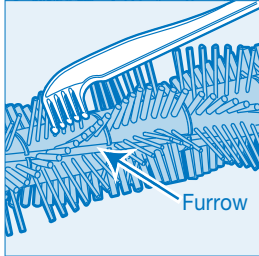
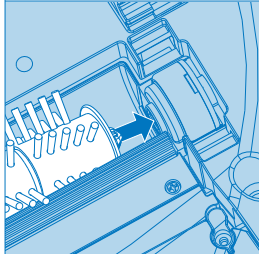
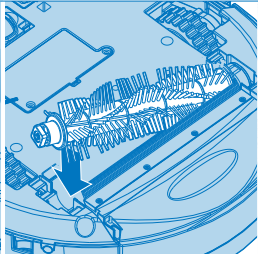
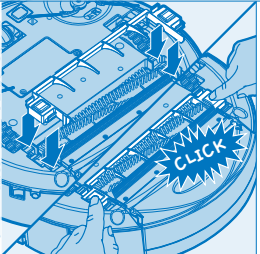
	<ol style="list-style-type: none"> 1. Empty the dust bin first. 2. Turn eX500 over and place the bottom facing upside. 		<ol style="list-style-type: none"> 2. Unlock the left/right-fixed clip of the main brush.
	<ol style="list-style-type: none"> 4. Separate the brush cover then remove the main brush. 		
 <p>Furrow</p>	<ol style="list-style-type: none"> 5. Clean hair, carpet fiber and other substances may get stuck on the main brush using the cleaning brush. Over time, hairs and fibers accumulate between the main brush and the bearing. This extra friction which will causes less efficient cleaning, more battery strain leading to shorter running time and may ultimately stop eX500. ※ Use scissors or a knife along the main brush furrow to remove the hair. 		
		 <p>CLICK</p>	<ol style="list-style-type: none"> 6. After cleaning, put the pyramid-shaped bump on the side of the main brush to the pyramid-shaped recess on the bottom of the robot. (Insert firmly to ensure there is No gap between the brush and the cam.)

Cleaning the Front Wheel

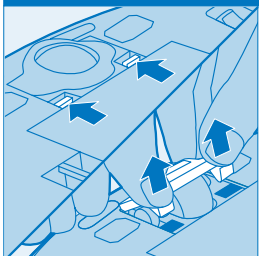
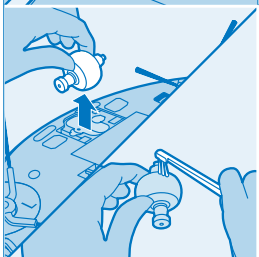
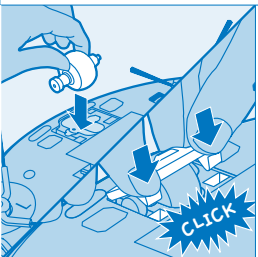
	<ol style="list-style-type: none"> 1. Press the front-wheel fix clip with both hands and lift up to separate. 2. Remove foreign substances on the front wheel using the cleaning brush. 		
	 <p>CLICK</p>	<ol style="list-style-type: none"> 3. Pull out the front-wheel then clean dust and foreign substance using the cleaning brush. 4. Put the front wheel back and lock in place with the clip. 	

Storage

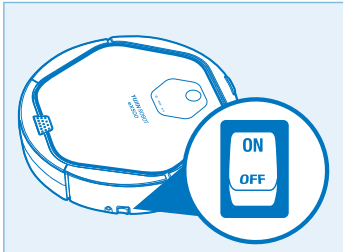

1. If eX500 is not used for a long period of time, turn off the Power Switch on the side of the Main Body.

※ Please be aware that the battery could be discharged after an extended period of non-use.

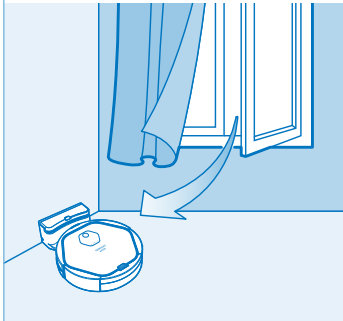

2. Keep eX500 away from direct sunlight. Store eX500 in a well ventilated location.

※ Please do not store any objects on top of eX500 as it may cause a malfunction



Below is the explanation about the most occurred 'breakdowns' when using this product.

If you can't solve the problem with information below, please call your Customer service center.

Problem	Cause	Solution
It is not cleaning well.	<ul style="list-style-type: none"> ▶ Dust Bin is full. ▶ Main Brush is dirty. ▶ Filter is contaminated. 	<ul style="list-style-type: none"> ▶ See <Product care & maintenance> and empty the dust bin. ▶ See <Product care & maintenance> and use main brush. ▶ See <Product care & maintenance> and clean the dirty filter.
When I press the power button to turn on eX500, it turns off automatically.	<ul style="list-style-type: none"> ▶ Battery is low. ▶ Battery is charged but the dust bin is full. ▶ Main brush is clogged with hair and dust. 	<ul style="list-style-type: none"> ▶ Charge eX500. ▶ See <Product care & maintenance> and empty the dust bin. ▶ See <Product care & maintenance> and clean main brush.
eX500 is not responding.	<ul style="list-style-type: none"> ▶ Power switch is turned off. ▶ Remote Control batteries are dead. ▶ Infrared sensor or beam window of the remote control are blocked or dirty. ▶ Remote control is too close to the Charging station or eX500. 	<ul style="list-style-type: none"> ▶ Check the power switch on the bottom of the main body. ▶ Re-charge eX500. ▶ Insert the battery of eX500 properly. ▶ Change the battery of a remote control. ▶ Wipe the infrared sensor & beam part of the remote control with soft cloth.
eX500 is not charging.	<ul style="list-style-type: none"> ▶ Charging station or eX500 is not connected properly to the plug. 	<ul style="list-style-type: none"> ▶ Move farther away from the Charging Station and press the button again while pointing at eX500.
After cleaning, eX500 is not returning to the charging station.	<ul style="list-style-type: none"> ▶ Power of the charging station is not connected properly. ▶ Infrared generator & ejector on the Charging station and detector of eX500 is dirty. ▶ Cleaning started with auto-mode but not from the charging station. 	<ul style="list-style-type: none"> ▶ Connect the power of the Charging Station properly. ▶ Move the Charging Station. No objects should be placed within 20 inches left/right or 5 feet in front of the Charging Station. This is to enable eX500 to return to the home station automatically after cleaning. ▶ eX500 must start cleaning from the charging station to return to the charging station after cleaning.

<p>Noise of the eX500 is getting worse.</p>	<ul style="list-style-type: none"> ▶Dust bin is full or filter is dirty. ▶Main brush is dirty. ▶Main brush is dirty or hairs are accumulating between the main brush and the bearing. 	<ul style="list-style-type: none"> ▶Empty and clean the dust bin. ▶See <Product care & maintenance> (page 13) and clean the filter. ▶See <Product care & maintenance> (page 14) and clean the main brush.
---	--	--

Error Codes

Error display	Cause	Solution
C 1	Lifted wheel	Move eX500 to flat area.
C 2	Cannot detect floor	Move eX500 to flat area in case the wheel is stuck on an obstacle.
C 3	Dust bin error	Dust bin is not properly assembled. See <Product care & maintenance> and install properly.
C 4	Wheel motor overload	Check if a foreign material such as hair or lint exists on the wheel. See <Product care & maintenance> and remove the foreign material.
C 5	Brush motor overload	Check if a foreign material such as hair or lint exists on the main brush or side-brush. See <Product care & maintenance> and remove the foreign material.
C 6	Suction motor overload	See <Product care & maintenance> and clean filter, empty the dust bin.
C 7	Internal system error	Turn off the power switch of eX500 then turn it on again.
C 8	Magnetic Sensor	Check that the front wheel & magnetic sensor are clean and correctly installed.

YUJIN ROBOT

eX500

Model Name	eX500 (YCR-M05-**)
Power	100 V ~ 240 V
Stand-by Power Consumption	Below 1 W
Main Body Energy Consumption	12 W
Battery	Lithium Ion Battery
Diameter	13.8 inches
Height	3.5 inches
Weight	6.17 lbs
Speed	250 mm/s
Filter	Antibacterial filter
Sensor	Camera, IR, PSD, Gyro, Encoder, Bumper
Charging Time	110 min.
Usage Time	120 min. (based on normal floor)
Noise	58 dB[A]

Yujin Robot Customer Support : 1.855.926.1601

- **Monday-Friday** 9 am to 6pm PST
- **Saturdays** Closed
- **Sundays** Closed

MADE IN KOREA

©2014 Yujin Robot Inc.
16410 Manning Way, Cerritos, CA 90703
support@yujinrobotusa.com
T 562.926.1601 F 562.926.1629
www.yujinrobotusa.com

One-Year Limited Warranty.

Specifications and features are subjected to change without notice.

