

## Limited Warranty

True Innovations seating products are warranted against defects in material and workmanship while owned by the "Original Purchaser". The term "Original Purchaser" is defined as that party or entity which purchases True Innovations furniture from an authorized True Innovations retailer as shown by the **original sales receipt**. This warranty does not apply to "as is" or previously owned seating products.

True Innovations warrants its products to be free from defects in materials and workmanship (normal wear and tear, fading and stretching excepted), for one year from the date of purchase, except as provided below under the limited warranty.

The exceptions or exclusions to this warranty are as follows:

1. Any warranty claim that is submitted after the limited warranty period, or without proper proof of purchase will not include the cost of parts, labor, or delivery.
2. This warranty shall not apply to the True Innovations products which have been subjected to misuse, neglect, alteration, modification, or attachments, either caused by the original purchaser, shipping, storage, accident, fire, flood, or acts of God.

In the event of a defect in material or workmanship covered by this warranty, True Innovations will repair or replace, at their discretion, without charge the warranted furniture within a reasonable amount of time. We reserve the right to require damaged parts to be returned to us upon request. Natural markings such as scars, brands, grain variations, wrinkles, color variations, etc. will be considered normal characteristics and not construed as defects. We cannot warrant leather against scratching or scuffing, as all leather is subject to blemishes with use.

For claims or questions concerning this warranty, please contact True Innovations Customer Service department on the web at [www.truecustomersupport.com](http://www.truecustomersupport.com). Be prepared to provide your name, address, daytime phone number, the model and purchase order number of the product, date of purchase, and the store where it was purchased. True Innovations requires that the original sales receipt be submitted with all requests to confirm that you are the original purchaser according to our written warranty.

This warranty gives you specific rights, and you may also have other rights, which vary from state to state.

All warranties are limited to the original purchaser for normal use which is defined as a standard work week of forty hours by a person weighing less than 250 lbs.

Should you prefer to speak with a service representative, you may call toll free: 1-855-372-2315.

## Chloe Arm Chair Assembly Instructions

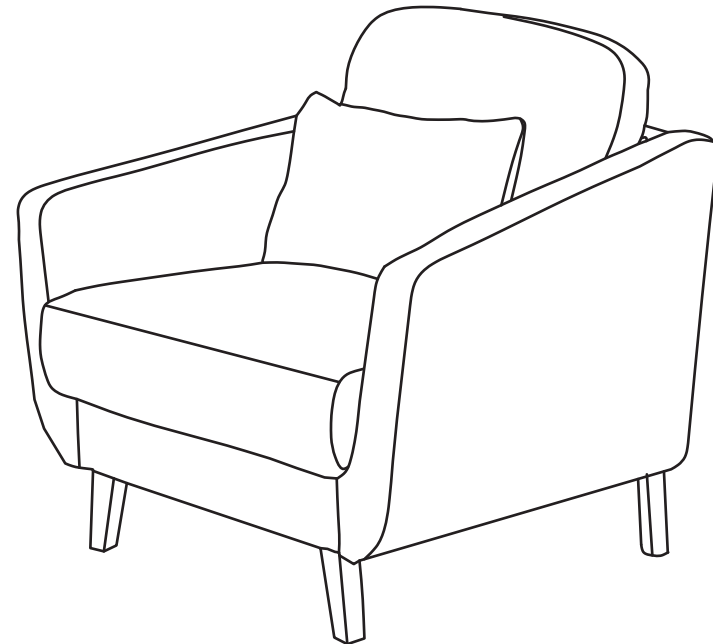

THIS INSTRUCTION BOOKLET CONTAINS IMPORTANT SAFETY INFORMATION.  
PLEASE READ AND KEEP FOR FUTURE REFERENCE.

Customer Service: 1-855-372-2315



**Thank you for selecting one of True Innovations seating solutions.**

It's True...Fast, Friendly Customer Service

At True Innovations, we are committed to excellence. Our primary objective is to provide fast, friendly customer service to all of our customers.

We are here to help if you have any questions, comments, or are in need of warranty replacement parts.

Please call us toll free at: **1-855-372-2315**  
 (Monday - Friday 6:00am - 5:00pm P.S.T)  
 or visit website:  
**www.truecustomersupport.com**

**Step 6 --** Open the vacuum packed Seat Cushion (I) by carefully cutting the bag with a pair of scissors. Insert the Seat Cushion (I) into the appropriate Seat Cover (K). Remember to keep the top side of the Seat Cushion (I) with the top side of the Seat Cover (K). Fluff all cushions and pillow to allow them to expand. Lastly, position all cushions and pillow on the chair. Seat and back cushions may take 24-48 hours to fully expand, which will allow wrinkles and indentations caused by packing to fade.  
 Note: There is a velcro between the back cushion and the back frame. Please stick them according to the location.

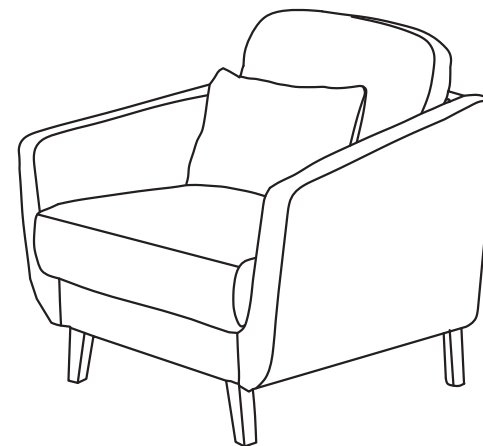
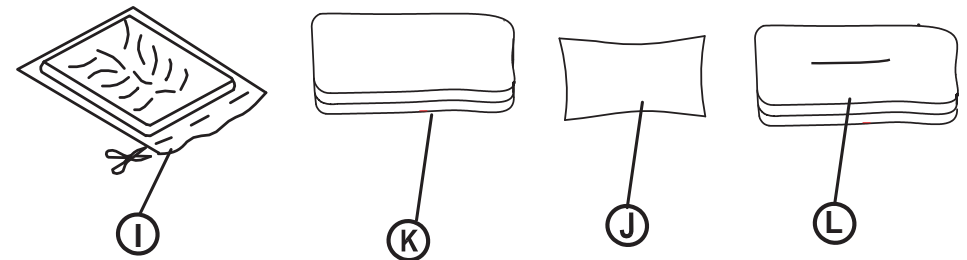

**Diagram 1**



**Diagram 2**

**ATTENTION:** To close the zipper, please follow diagram 1. Failure to follow this could result in damage to the zipper.

**Step 5** -- Secure the bottom flap with hook and loop tape.

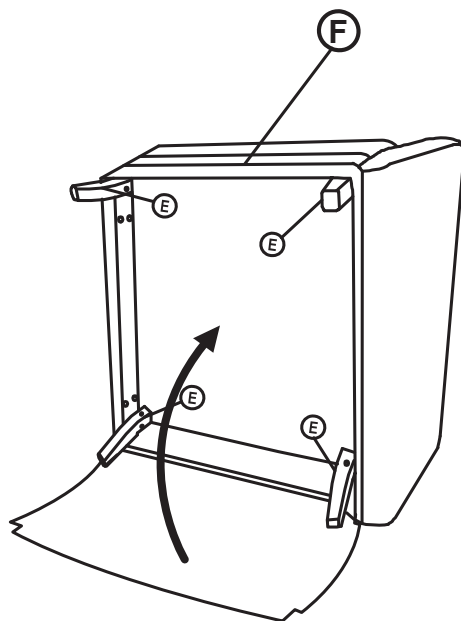

**NOTES:**

- Please read the instruction sheets completely before assembly.
- Remove all parts from carton and ensure all parts are included prior to assembly.
- Assemble the sofa on a protected surface to avoid scratching the components of chair.
- Be careful not to cross-thread screws.
- Do not use power tools.
- Two people are recommended for assembly.
- Seat and back cushions may take 24-48 hours to fully expand, which will allow wrinkles and indentations caused by packing to fade.
- A compressed product assumes its proper shape and volume within 3-4 days.
- Take care not to damage the product if you use scissors or a knife when opening the package.

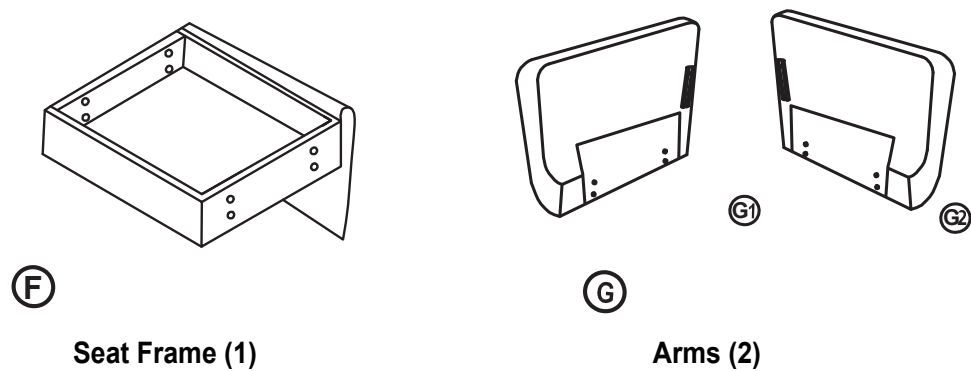
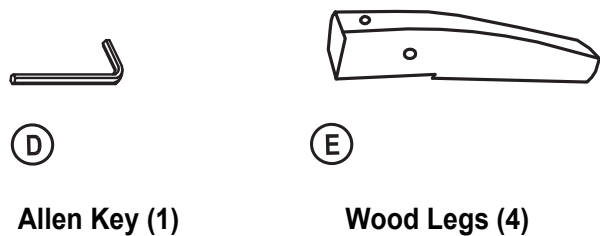

**Step 4 --** Insert Wood Legs (E) into the bottom of the chair as shown and connect with 2.5" Screws (A) with Spring Washers (B) and Flat Washers (C). Do not tighten screws fully until you have completed assembly. Place chair upright on level floor. Make any necessary adjustments to frame to ensure chair sits flat on floor without rocking, then tighten all screws securely with Allen Key (D).

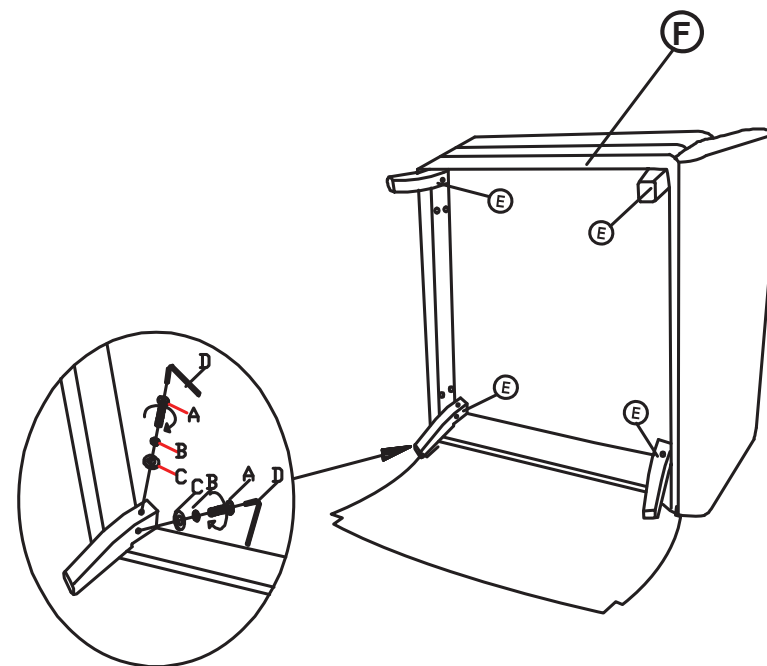

**Step 3 --** Attach the Back Frame (H) to the seat frame by sliding the receivers into the mechanism posts located on the Arms (G1 & G2). From the front of the chair, press down on both sides of the Back Frame (H) to firmly secure. The Back Frame (H) and Seat Frame (F) will automatically lock into place. Then pull the back flap down tightly and attach the back flap to the bottom of the Seat Frame (F).

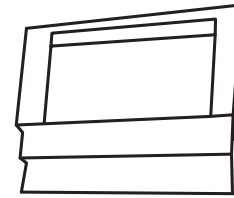
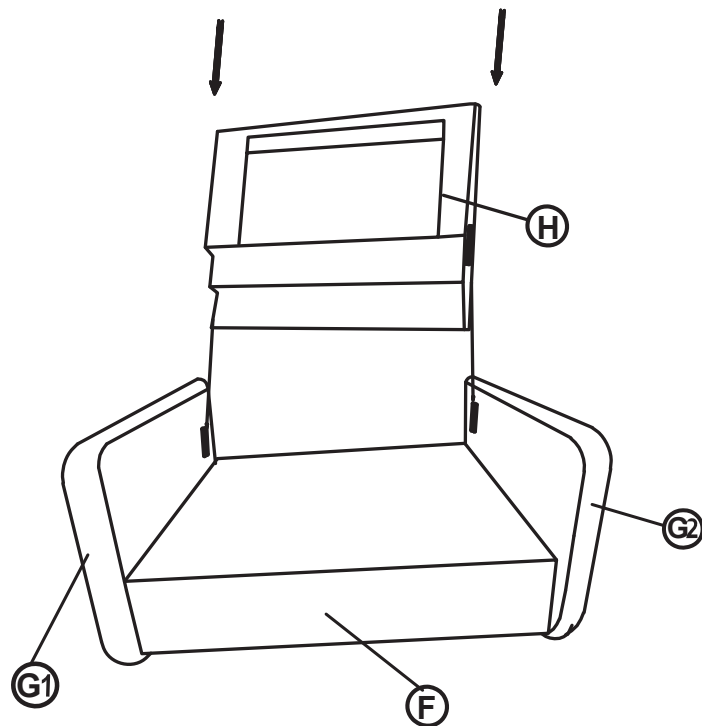

**(H)**  
Back Frame (1)

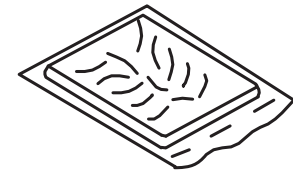

**(I)**  
Seat Cushion (1)



**(J)**  
Pillow (1)



**(K)**  
Seat Cushion Cover (1)



**(L)**  
Back Cushion (1)



**Step 1 --** Remove all parts from the carton and place them on a protected surface or carpet. Place the Seat Frame (F) upside down and open the bottom flap. Take the Screws (A), Spring Washers (B), Flat Washers (C), Allen Key (D), Wood Legs (E), Seat Cushion (I), Seat Cushion Cover (K) and Pillow (J) out of the seat box.

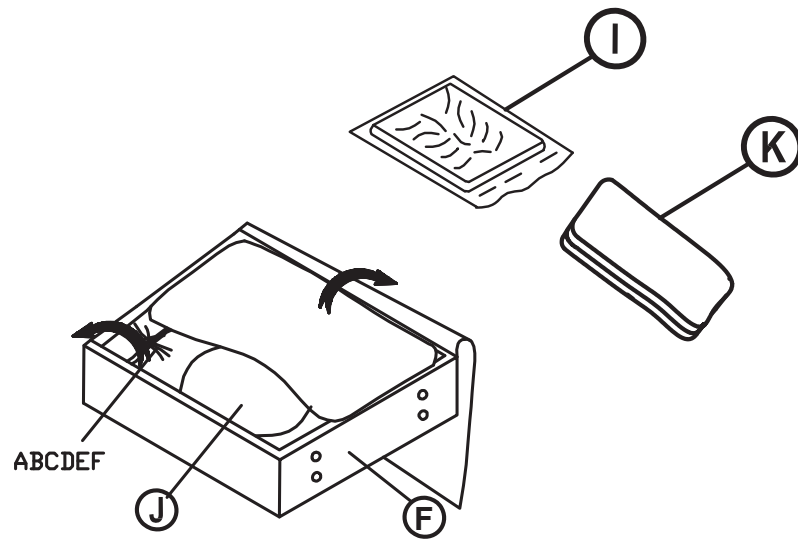

**Step 2 --** Insert 2.5" Screws (A), Spring Washers (B) and Flat Washers (C) into seat frame holes, attaching Arms (G1 & G2) to sides of Seat Frame (F) and tighten the screws.

