

INSTALLATION

Installation Overview

Please read the following installation instructions first after purchasing this product or transporting it to another location.

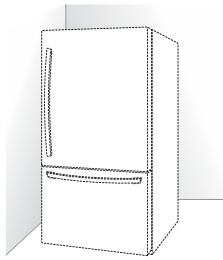

1 Unpacking your refrigerator

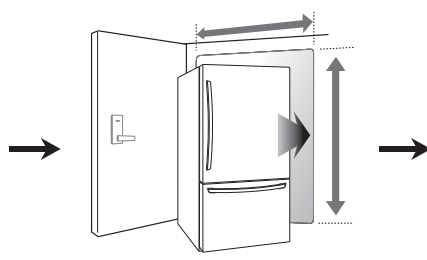

2 Choosing the proper location

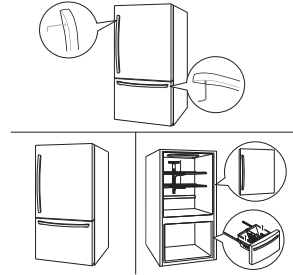

3 Disassembling/Assembling

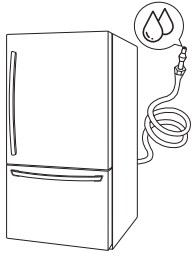

4 Connecting the water supply and water line
(Ice maker installed only)

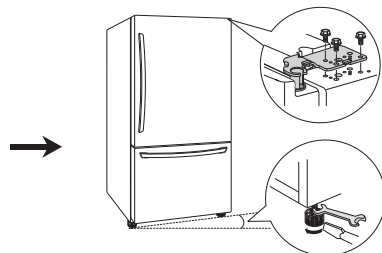

5 Leveling and Door Alignment

Specifications

The appearance and specifications listed in this manual may vary due to constant product improvements.

Dimensions	24 cu. ft. models	32 3/4" (W) X 34 7/8" (D) X 69 7/8" (H), 62 3/4" (D w/ door open) 833.1 mm (W) X 886.4 mm (D) X 1775.5 mm (H), 1592.5 mm (D w/ door open)
	22 cu. ft. models	29 3/4" (W) X 34 7/8" (D) X 68 1/2" (H), 59 3/4" (D w/ door open) 756.9 mm (W) X 886.4 mm (D) X 1739.9 mm (H), 1516.5 mm (D w/ door open)
Net weight	24 cu. ft. models	248.5 lb. (112.7 Kg) – Freezer Drawer models 235.2 lb. (106.7 Kg) – Freezer Swing models
	22 cu. ft. models	230.8 lb. (104.7 Kg) – Freezer Drawer models 216.3 lb. (98.1 Kg) – Freezer Swing models

Unpacking Your Refrigerator

DANGER

- Use two or more people to move and install the refrigerator. Failure to do so can result in back or other injury.
- Your refrigerator is heavy. When moving the refrigerator for cleaning or service, be sure to protect the floor. Always pull the refrigerator straight out when moving it. Do not wiggle or walk the refrigerator when trying to move it, as floor damage could occur.
- Keep flammable materials and vapors, such as gasoline, away from the refrigerator. Failure to do so can result in fire, explosion, or death.

Remove tape and any temporary labels from your refrigerator before using. Please remove vinyl from doors before connecting unit to the electrical supply (on some models). Do not remove any warning-type labels, the model and serial number label, Installations labels or the Circuit Diagram located in the backward of refrigerator.

To remove any remaining tape or glue, rub the area briskly with your thumb. Tape or glue residue can also be easily removed by rubbing a small amount of liquid dish soap over the adhesive with your fingers. Wipe with warm water and dry.

Do not use sharp instruments, rubbing alcohol, flammable fluids, or abrasive cleaners to remove tape or glue. These products can damage the surface of your refrigerator.

Refrigerator shelves are installed in the shipping position. Please reinstall shelves according to your individual storage needs.

Choosing the Proper Location

- Select a place where a water supply can be easily connected for the automatic icemaker.

NOTE

The water pressure must be between 20 and 120 psi (0,138 - 0,82 MPa) on models without a water filter and between 40 and 120 psi (0,276 - 0,82 MPa) on models with a water filter.

- The refrigerator should always be plugged into its own individual properly grounded electrical outlet rated for 115/127 V ~ 60 Hz, AC only, and fused at 15 A. This provides the best performance and also prevents overloading house wiring circuits which could cause a fire hazard from overheated wires. It is recommended that a separate circuit serving only this appliance be provided.

CAUTION

To reduce the risk of electric shock, do not install the refrigerator in a wet or damp area.

Flooring

To avoid noise and vibration, the unit must be leveled and installed on a solidly constructed floor. If required, adjust the leveling legs to compensate for unevenness of the floor. The front should be slightly higher than the rear to aid in door closing. The leveling legs can be turned easily by tipping the cabinet slightly. Turn the leveling legs to the left to raise the unit or to the right to lower it. (See Leveling and Door Alignment.)

NOTE

Installing on carpeting, soft tile surfaces, a platform or weakly supported structure is not recommended.

Ambient Temperature

Install this appliance in an area where the temperature is between 55°F (13°C) and 110°F (43°C). If the temperature around the appliance is too low or high, cooling ability may be adversely affected.

Measuring the Clearances

Too small of a distance from adjacent items may result in lowered freezing capability and increased electricity consumption charges. Allow at least 33 ¾ inches (86 cm) in front of the refrigerator to open the doors, and at least 2 inches (5.08 cm) between the back of the refrigerator and the wall.

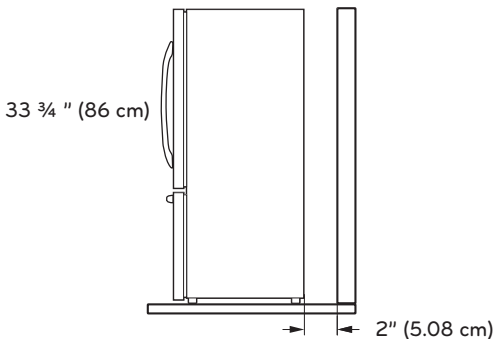

Removing/Assembling the Refrigerator Door Handles

NOTE

When it is necessary to move the refrigerator through a narrow opening, removing the doors is the recommended procedure. If it is necessary to remove the handles, follow the directions below. The appearance of the handle may vary from what is shown in the illustrations.

Removing the Handles

- 1 Loosen the set screws **1** with a $\frac{3}{32}$ in. (2.5 mm) Allen wrench and remove the handle.
- 2 Loosen the mounting fasteners **2** that connect to the refrigerator door and handle using a $\frac{1}{4}$ in. (6.35 mm) Allen wrench, and remove the mounting fasteners.

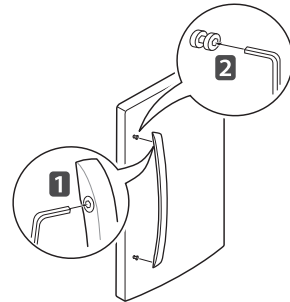

Assembling the Handles

- 1 Assemble the mounting fasteners **1** at both ends of the handle using a $\frac{1}{4}$ in. (6.35 mm) Allen wrench.
- 2 Place the handle on the door by fitting the handle footprints over the mounting fasteners and tightening the set screws **2** with a $\frac{3}{32}$ in. (2.5 mm) Allen wrench.

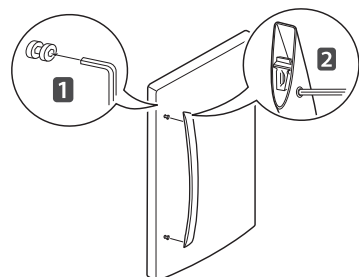

Removing/Assembling the Freezer Drawer Handle (On Freezer Drawer Models)

Removing the Handle

- 1 Loosen the set screws **1** located on the lower side of the handle with a $\frac{3}{32}$ in. (2.5 mm) Allen wrench and remove the handle.
- 2 Loosen the mounting fasteners **2** that connect to the freezer drawer and handle using a $\frac{1}{4}$ in. (6.35 mm) Allen wrench, and remove the mounting fasteners.

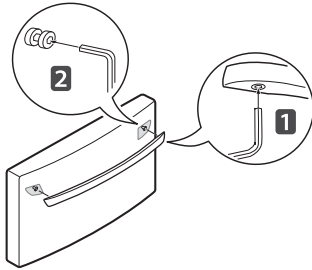

Assembling the Handle

- 1 Assemble the mounting fasteners **1** at both ends of the handle using a $\frac{1}{4}$ in. (6.35 mm) Allen wrench.
- 2 Place the handle on the door by fitting the handle footprints over the mounting fasteners and tightening the set screws **2** with a $\frac{3}{32}$ in. (2.5 mm) Allen wrench.

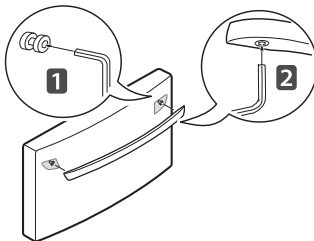

Removing/Assembling the Doors and Drawers

When it is necessary to move the refrigerator through a narrow opening, removing the doors is the recommended procedure.



CAUTION

- If your entrance door is too narrow for the refrigerator to pass through, remove the refrigerator doors and move the refrigerator sideways through the doorway.
- Use two or more people to remove and install the refrigerator doors. Failure to do so can result in back or other injury.
- Disconnect the electrical supply to the refrigerator before installation. Failure to do so could result in serious injury or death.
- Do not put hands, feet or other objects into the air vents or bottom of the refrigerator. You may be injured or receive an electrical shock.
- Be careful when handling the hinge and stopper. You may be injured.
- Remove food and bins before detaching the doors and drawers.



CAUTION

When assembling or disassembling the handles:

- Grasp the handle tightly to avoid dropping it.
- Do not swing the handle into nearby people or animals.
- Make sure that the bracket hole of the handle fits properly into the stopper bolt of the door. Assemble the set screws to fix the handle into place.
- Make sure that there is not a gap between the door and handle after assembling the handle.

Removing the Refrigerator Door

- 1 Remove the top hinge cover screws **1**. Lift the hook (not visible), located at the bottom of the front side of the cover **2**, with a flat-head screwdriver.

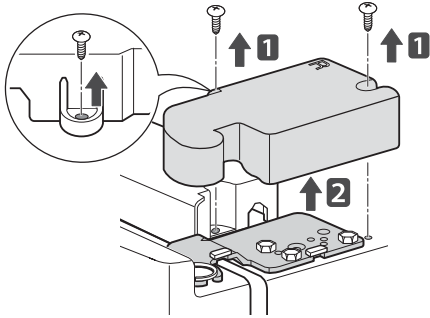

- 2 Remove the three bolts using a 10mm or 13/32-inch socket wrench and lift off the top hinge. Set parts aside.

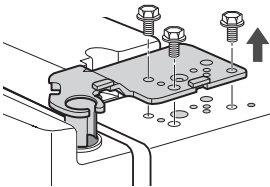

WARNING

When lifting the hinge, be careful that the door does not fall forward.

- 3 Lift the door from the middle hinge pin and remove the door.

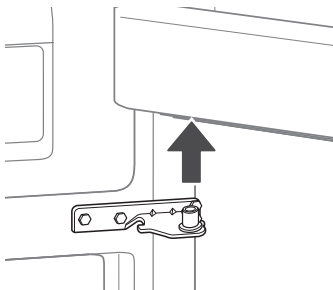

WARNING

Place the door, inside facing up, on a non-scratching surface.

Assembling the Refrigerator Door

- 1 Make sure that the plastic sleeve is inserted in the bottom of the door. Lower the door onto the middle hinge pin as shown in the figure.

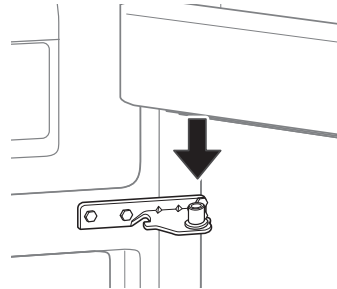

- 2 Line up the top hinge with the holes in the top of the refrigerator. Use the three bolts to replace the hinge. Tighten the bolts.

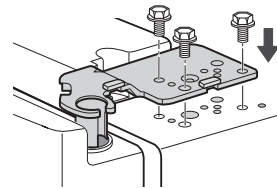

- 3 Replace the cover. Insert and tighten the cover screws **2**.

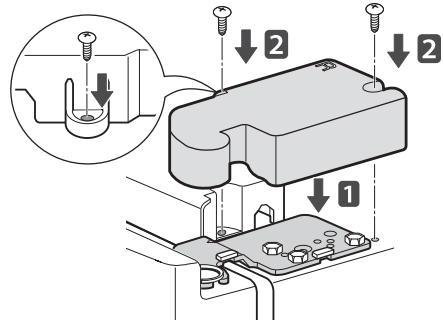

Removing the Freezer Drawers (On Freezer Drawer Models)

The top and bottom drawers are all removed in the same way. In the following figures, the Pullout Drawer located above the freezer drawer is not shown for clarity.



WARNING

- Use two or more people to remove and install the freezer drawer. Failure to do so can result in back or other injury.
- Do not hold the handle when removing or replacing the drawer. The handle may come off, causing personal injury.
- Be careful of sharp hinges on both sides of the drawer.
- When you lay the drawer down, be careful not to damage the floor.
- Do not sit or stand on the freezer drawer.
- To prevent accidents, keep children and pets away from the drawer. Do not leave the drawer open.

- 1 Pull the drawer open to full extension.
- 2 Lift the Durabase basket up and out, making sure to clear the rail system.

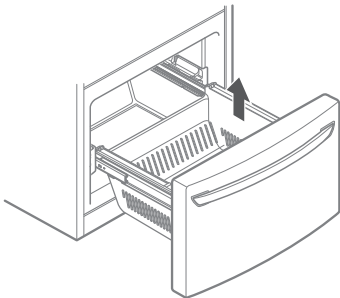

- 3 Remove the screws at the ends of both rails.

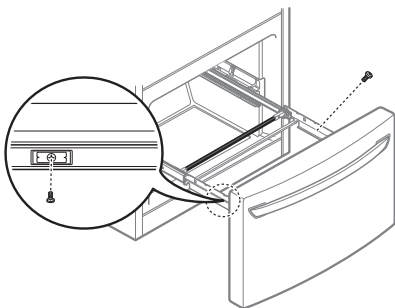

- 4 Slide out the bar.

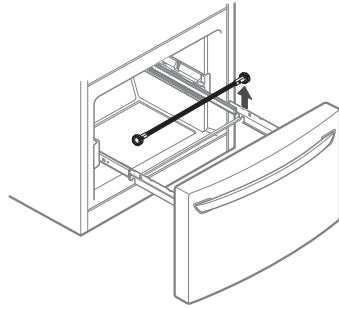

- 5 Grip both sides of the drawer and pull it up to remove it from the rails.



WARNING

Do not hold the handle when removing or replacing the drawer. The handle may come off, causing personal injury.

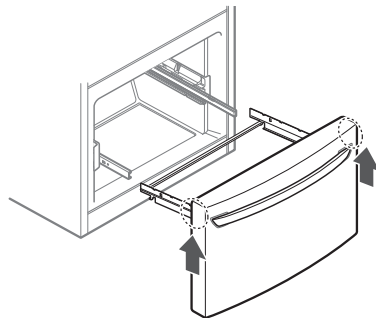

- 6 Holding one rail with each hand, push the rails in simultaneously.

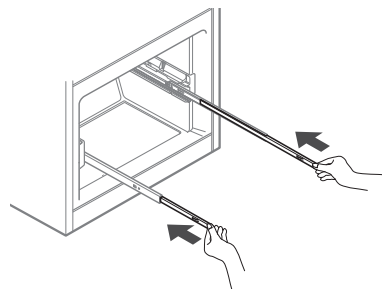

Assembling the Freezer Drawers (On Freezer Drawer Models)

The top and bottom drawers are all assembled in the same way.

- 1 Using two hands, pull out both rails simultaneously until they are fully extended.

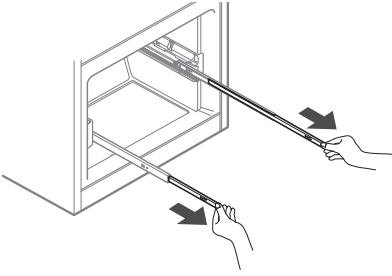

- 2 Grasp the drawer on each side and hook the drawer supports into the rail tabs located on both sides.

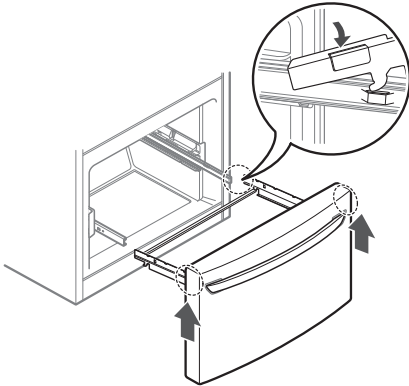

CAUTION

Do not hold the handle when removing or replacing the drawer. The handle may come off, causing personal injury.

- 3 Reinstall the bar in the drawer supports.

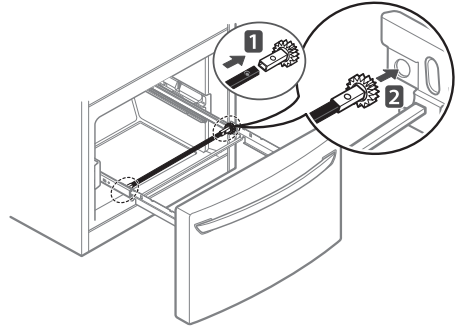

- 4 Lower the door into final position and tighten the screws located on both sides.

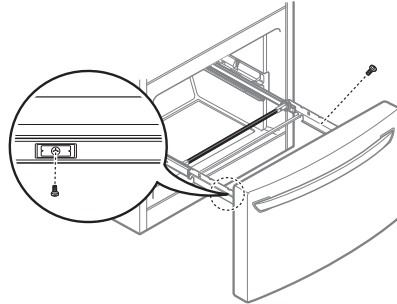

- 5 With the drawer pulled out to full extension, insert the lower basket in the rail assembly.

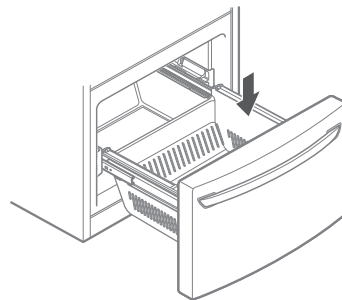

Removing the Freezer Door (On Freezer Swing Models)

Before beginning, make sure you completely remove the refrigerator door.

See Removing the Refrigerator Door (p.15)



WARNING

- Use two or more people to remove and install the freezer door. Failure to do so can result in back or other injury.
- When you lay the door down, be careful not to damage the floor.
- Do not sit or stand on the freezer door.
- To prevent accidents, keep children and pets away from the door. Do not leave the door open.

- 1 Use a 1/4 in. (6.35 mm) hex socket wrench to loosen and remove the hinge pin from the middle hinge bracket. Use a 13/32 in. or 10 mm socket wrench to remove the two bolts. Remove the screw and the washer, and set the middle hinge and other parts aside.

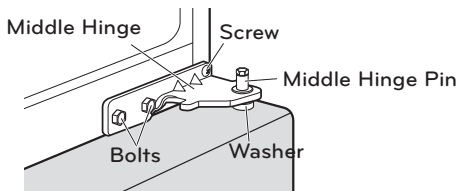

- 2 Carefully lift up the freezer door. Remove and place it on a non-scratching surface.

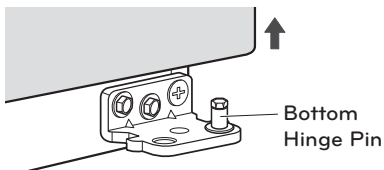

Assembling the Freezer Door (On Freezer Swing Models)

- 1 Place the freezer door down on the bottom hinge pin.

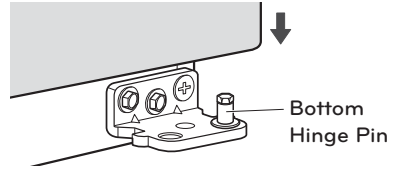

- 2 Put the washer between the freezer door and the middle hinge.
- 3 Attach the middle hinge with the previously removed two bolts and screw. Reattach the middle hinge pin using a 1/4 in. (6.35 mm) hex socket wrench.

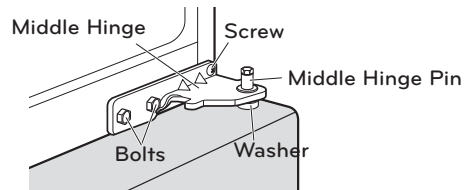

Reversing Door Opening Direction

NOTE

To assist in the installation of the handle on the right side, place a piece of masking tape near the top of the handle before removing it. The appearance of the handle may vary from what is shown in the illustrations.

- 4 Assemble the mounting fasteners **1** at both ends of the handle using a $\frac{1}{4}$ in. (6.35 mm) Allen wrench.
- 5 Place the handle on the door by fitting the handle footprints over the mounting fasteners and tightening the set screws **2** with a $\frac{3}{32}$ in. (2.5 mm) Allen wrench.

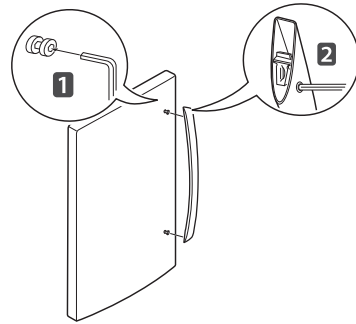

Reversing the Refrigerator Handle

- 1 Loosen the set screws **1** with a $\frac{3}{32}$ in. (2.5 mm) Allen wrench and remove the handle.
- 2 Loosen the mounting fasteners **2** that connect to the refrigerator door and handle using a $\frac{1}{4}$ in. (6.35 mm) Allen wrench, and remove the mounting fasteners.

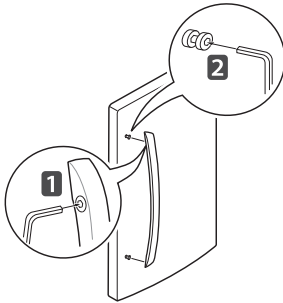

- 3 Carefully loosen the plug buttons **4** with your fingers. The buttons can be unscrewed with the fingers by rotating them counter-clockwise and continuing until they loosen and fall out. The buttons were installed without pressure, and for this reason, they can be unscrewed using your index finger, thumb or both. Install the plug buttons **5** on the left side.

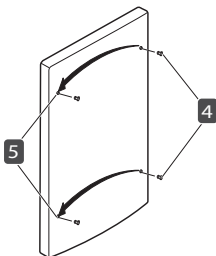

Reversing the Doors (On Freezer Drawer Models)

- 1 Remove the top hinge cover screws **1**. Lift the hook (not visible), located at the bottom of the front side of the cover **2**, with a flat-head screwdriver.

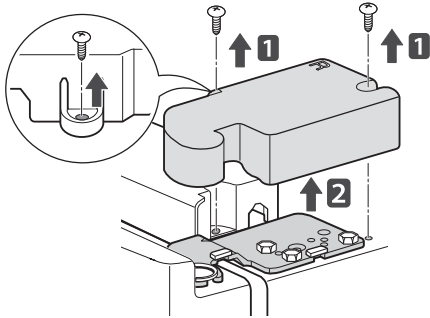

- 2 Using a 13/32 in. or 10 mm socket wrench, remove the three bolts and lift off the top hinge. Set parts aside.

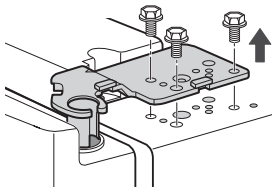

WARNING

When lifting the hinge, be careful that the door does not fall forward.

- 3 Lift the door from the middle hinge pin and remove the door.

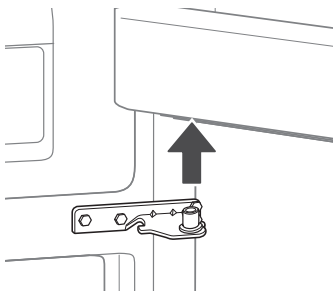

WARNING

Place the door, inside facing up, on a non-scratching surface.

- 4 Remove the four screws **1**, the hinge pin insert **2** and the hinge pin brackets **3** from the bottom right side of the door.

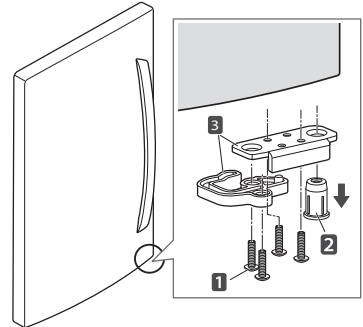

- 5 Reinstall the hinge pin brackets **1**, screws **2** and hinge pin insert **3** on the bottom left side of the door.

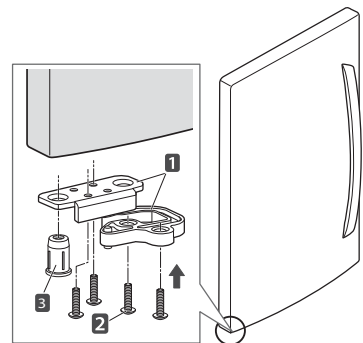

- 6 Use a 1/4 in (6.35 mm) hex socket wrench to loosen the hinge pin **1** and remove. Remove the two bolts **2**, the screw **3** and the hinge **4**.

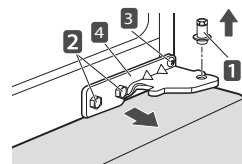

- 7 With a flat-head screwdriver, carefully pry off and remove the cover over the bolt holes on the left side of the refrigerator.

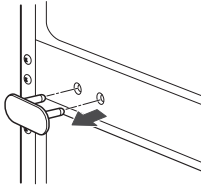

- 8 Remove the outer lower decorative screw from the flange on the frame between the freezer and refrigerator doors. (You will need this hole for the middle hinge bracket.)

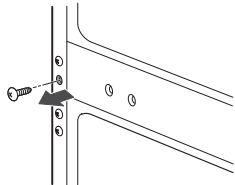

- 9 Flip the middle hinge bracket and position it on the left side of refrigerator and reattach with two bolts and a screw.

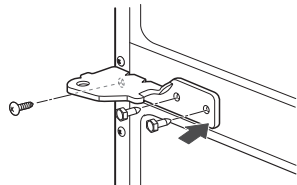

- 10 Reattach middle hinge pin using a ¼ in. (6.35 mm) socket wrench.

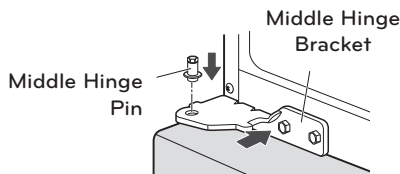

- 11 Insert the decorative screw into the outer hole on the right side of the flange. Attach the cover on the right side. Cover is force-fitted.

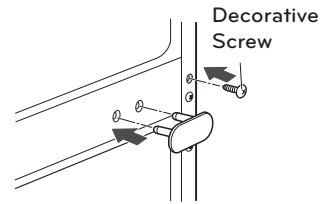

- 12 Loosen the two screws and remove the left hinge cap.

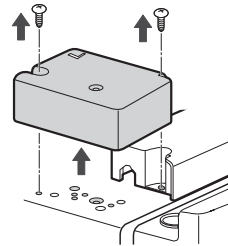

- 13 Place the refrigerator door down over the hinge pin on the middle hinge pin bracket.

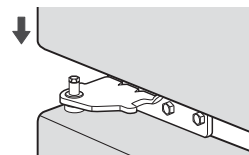

NOTE

The bracket has been flipped, but the hinge pin stays in the same orientation with its hexagonal end facing upward.

NOTE

The left top hinge, right hinge cap and left hinge cover are provided for reversing doors.

- Line up the left top hinge with the holes in the top of the refrigerator. Use the three bolts to replace the hinge.

Assemble the left hinge cover with the two screws.

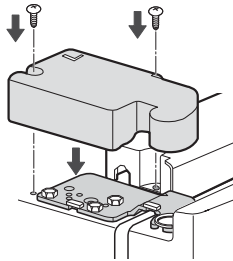

- Assemble the right hinge cap with the two screws.

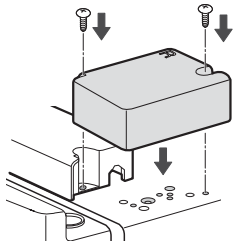

**Reversing the Doors
(On Freezer Swing Models)**

- Remove the top hinge cover screws 1. Lift the hook (not visible), located at the bottom of the front side of the cover 2, with a flat-head screwdriver.

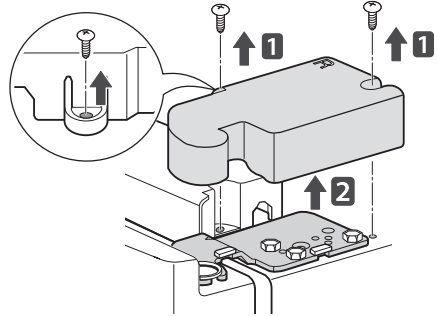

- Using a 10mm or 13/32 in. socket wrench, remove the three bolts and lift off the top hinge. Set parts aside.

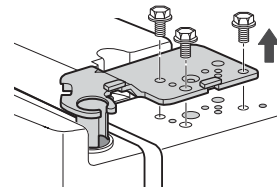

WARNING

When lifting the hinge, be careful that the door does not fall forward.

- Lift the door from the middle hinge pin and remove the door.

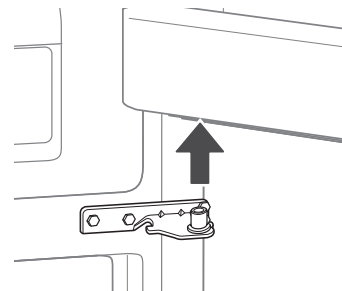

WARNING

Place the door, inside facing up, on a non-scratching surface.

- 4 Remove the four screws **1**, the hinge pin insert **2** and the hinge pin brackets **3** from the bottom right side of the door.

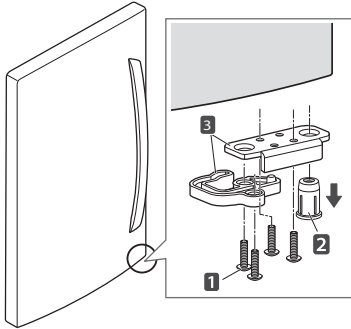

- 5 Reinstall the hinge pin brackets **1**, screws **2** and hinge pin insert **3** on the bottom left side of the door.

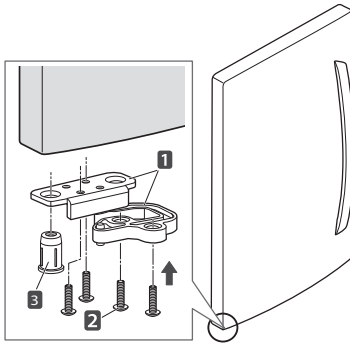

NOTE

Before removing the freezer door, make sure you completely remove the refrigerator door.

- 6 Use a ¼ in. (6.35 mm) hex socket wrench to loosen the hinge pin **1** and remove it. Remove the two bolts **2**, the screw **3** and the hinge **4**. Remove the washer.

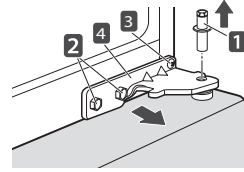

- 7 Carefully lift up the freezer door. Remove and place it on a non-scratching surface.

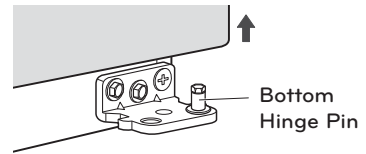

- 8 Using a ¼" (6.35 mm) socket wrench, loosen and remove the hinge pin from the bottom hinge.

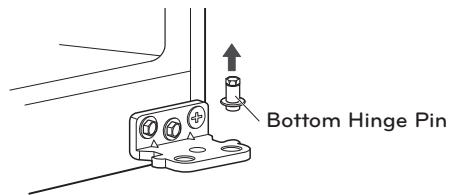

- 9 Using a 13/32-in. or 10mm socket wrench with a 2 in. (50 mm) extension and a screwdriver, loosen the two bolts and the screw, and remove the bottom hinge from the right side.

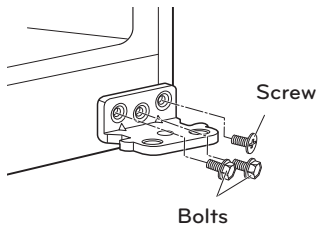

- 10 Remove the four screws **1**, the hinge pin brackets **2** and the hinge pin insert **3** from the bottom right side of the freezer door.

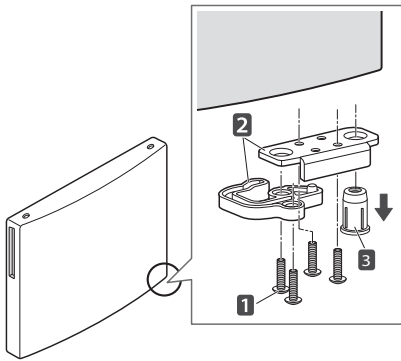

- 11 Reinstall the hinge pin insert **1**, the hinge pin brackets **2** and the screws **3** on the bottom left side of the door.

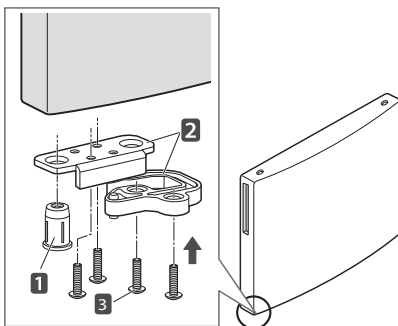

- 12 On the top part of the door, you will find a cap **1** and a pivot **2**. Remove them with a flat head screwdriver and install them on the opposite side (the cap goes on the right and the pivot on the left).

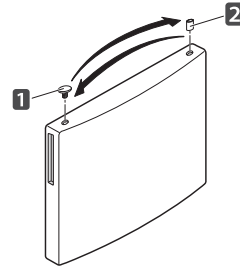

- 13 Remove the decorative caps on the bottom of the refrigerator housing. You will need these holes for the bottom hinge.

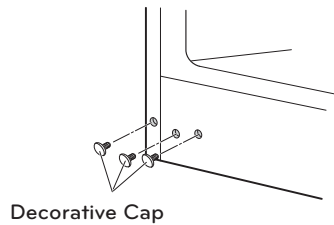

Decorative Cap

- 14 Using a 13/32 in. or 10 mm socket wrench with a 2 in. (50.8 mm) extension and a screwdriver, tighten the two bolts and the screw, and assemble the bottom hinge on the left side of the flange.

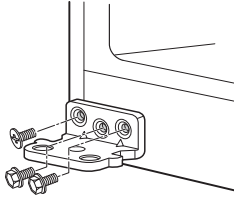

- 15 Attach the hinge pin using a 1/4 in. (6.35 mm) socket wrench.

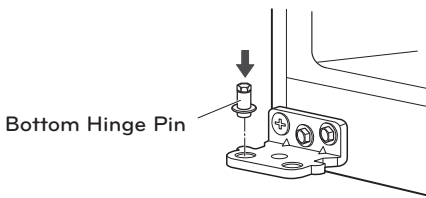

- 16 With a flat-head screwdriver, carefully pry off and remove the cover over the bolt holes on the left side of the refrigerator.

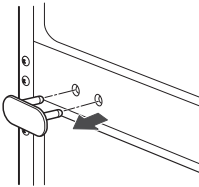

- 17 Remove the outer lower decorative screw from the flange on the frame between the freezer and refrigerator doors. (You will need this hole for the middle hinge bracket.)

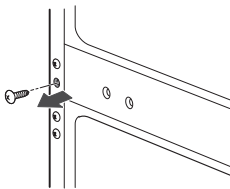

- 18 Flip the middle hinge bracket and position it on the left side of the refrigerator and reattach it with two bolts and a screw.

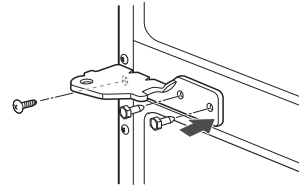

- 19 Place the freezer door down on the bottom hinge pin.

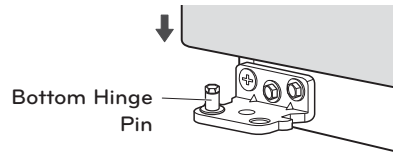

- 20 Reattach the middle hinge pin using a 1/4 in (6.35 mm) socket wrench. Replace the washer.

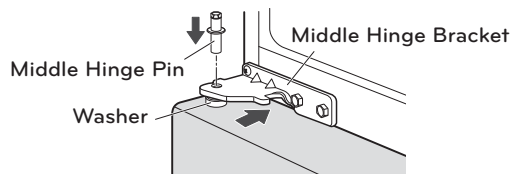

NOTE

The bracket has been flipped, but the hinge pin stays in the same orientation with its hexagonal end facing upward.

- 21 Insert the decorative screw into the outer hole on the right side of the flange. Attach the cover on the right side. Cover is force-fitted.

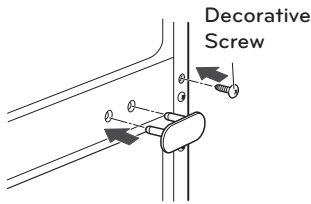

- 22 Loosen the two screws and remove the left hinge cap.

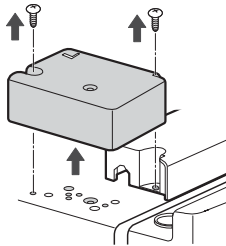

- 23 Place the refrigerator door down over the hinge pin on the middle hinge pin bracket.

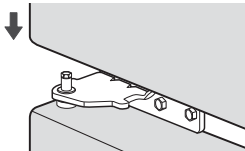

NOTE

The left top hinge, right hinge cap and left hinge cover are provided for reversing doors.

- 24 Line up the left top hinge with the holes in the top of refrigerator. Use the three bolts to replace the the hinge.

Assemble the left hinge cover with the two screws.

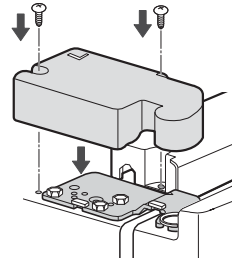

- 25 Assemble the right hinge cap with the two screws.

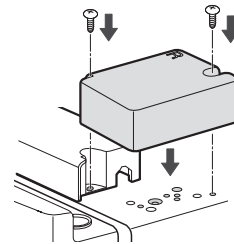

Connecting the Water Line (Ice maker installed only)

Before You Begin

This water line installation is not covered by the refrigerator warranty. Follow these instructions carefully to minimize the risk of expensive water damage.

Water hammer (water banging in the pipes) in house plumbing can cause damage to refrigerator parts and can lead to water leakage or flooding. Call a qualified plumber to correct water hammer before installing the water supply line to the refrigerator.



WARNING

To prevent burns and product damage, only connect the refrigerator water line to a cold water supply.

If you use your refrigerator before connecting the water line, make sure the icemaker power switch is in the OFF (O) position.



WARNING

Do not install the icemaker tubing in areas where temperatures fall below freezing.

Water Pressure

The water pressure must be between 20 and 120 psi on models without a water filter and between 40 and 120 psi on models with a water filter.

If a reverse osmosis water filtration system is connected to your cold water supply, this water line installation is not covered by the refrigerator warranty. Follow the instructions carefully to minimize the risk of expensive water damage.

If a reverse osmosis water filtration system is connected to your cold water supply, the water pressure to the reverse osmosis system needs to be a minimum of 40 to 60 psi (0,14 y 0,41 MPa) less than 2.0~3.0 sec. to fill a cup of 7 oz (0.2 L) capacity.



WARNING

Wear eye protection during installation to prevent injury.

If the water pressure from the reverse osmosis system is less than 21 psi or 0,14 MPa takes more than 4.0 sec to fill a cup of 7 oz capacity:

- Check to see if the sediment filter in the reverse osmosis system is blocked. Replace the filter if necessary.
- Allow the storage tank on the reverse osmosis system to refill after heavy usage.
- If water pressure issues associated with a reverse osmosis system persist, call a licensed, qualified plumber.
- All installations must be in accordance with local plumbing code requirements.

What You Will Need

- Copper Tubing, ¼ in. (6.35 mm) outer diameter, to connect the refrigerator to the water supply. Be sure both ends of the tubing are cut square.

To determine how much tubing you need: measure the distance from the water valve on the back of the refrigerator to the water supply pipe. Then, add 8 feet (2.4 m).

Be sure there is sufficient extra tubing (about 8 feet [2.4 m] coiled into three turns of about 10 in. [25 cm] diameter) to allow the refrigerator to move out from the wall after installation.

- Power drill.
- ½ in. (13 mm) or adjustable wrench.
- Flat blade and Phillips head screwdrivers.
- Two ¼ in. (6.35 mm) outer diameter compression nuts and 2 ferrules (sleeves) to connect the copper tubing to the shutoff valve and the refrigerator water valve.

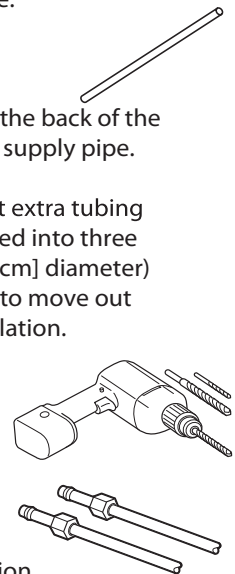

- If your existing copper water line has a flared fitting at the end, you will need an adapter (available at plumbing supply stores) to connect the water line to the refrigerator OR you can cut off the flared fitting with a tube cutter and then use a compression fitting.
- Shutoff valve to connect to the cold water line. The shutoff valve should have a water inlet with a minimum inside diameter of 5/32 in. (4 mm) at the point of connection to the COLD WATER LINE. Saddle-type shutoff valves are included in many water supply kits. Before purchasing, make sure a saddle-type valve complies with your local plumbing codes.

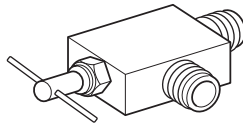
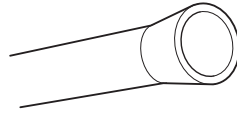

NOTE

A self piercing saddle type water valve should not be used.

Water Line Installation Instructions



CAUTION

When using any electrical device (such as a power drill) during installation, be sure the device is battery powered, double insulated or grounded in a manner that will prevent the hazard of electric shock.

Install the shutoff valve on the nearest frequently used drinking water line.

1 SHUT OFF THE MAIN WATER SUPPLY

Turn on the nearest faucet to relieve the pressure on the line.

2 CHOOSE THE VALVE LOCATION

Choose a location for the valve that is easily accessible. It is best to connect into the side of a vertical water pipe. When it is necessary to connect into a horizontal water pipe, make the connection to the top or side, rather than at the bottom, to avoid drawing off any sediment from the water pipe.

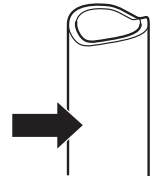

3 DRILL THE HOLE FOR THE VALVE

Drill a 1/4 in. (6.35 mm) hole in the water pipe using a sharp bit. Remove any burrs resulting from drilling the hole in the pipe. Be careful not to allow water to drain into the drill. Failure to drill a 1/4 in. (6.35 mm) hole may result in reduced ice production or smaller cubes.

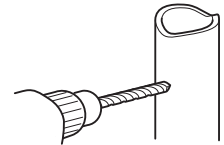

NOTE

The hookup line cannot be white, plastic tubing. Licensed plumbers must use only copper tubing (NDA tubing #49595 or #49599) or Cross Link Polyethylene (PEX) tubing.

4 FASTEN THE SHUTOFF VALVE

Fasten the shutoff valve to the cold water pipe with the pipe clamp.

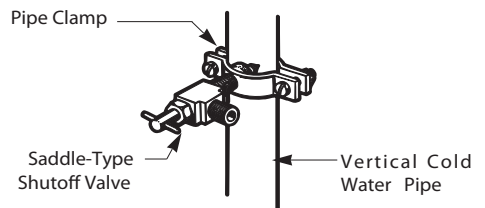

NOTE

Commonwealth of Massachusetts Plumbing Codes 248CMR shall be adhered to. Saddle valves are illegal and use is not permitted in Massachusetts. Consult with your licensed plumber by norms and regulations of your country.

5 TIGHTEN THE PIPE CLAMP

Tighten the clamp screws until the sealing washer begins to swell.

NOTE: Do not overtighten the clamp or you may crush the tubing.

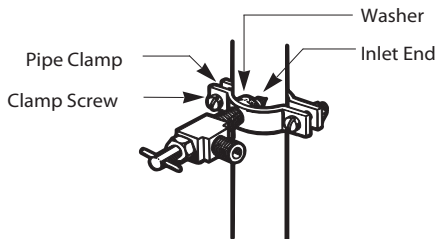

6 ROUTE THE TUBING

Route the tubing between the cold water line and the refrigerator.

Route the tubing through a hole drilled in the wall or floor (behind the refrigerator or adjacent base cabinet) as close to the wall as possible.

! NOTE

Be sure there is sufficient extra tubing (about 8 feet or 2.4 m coiled into 3 turns of about 10 in. or 25 cm diameter) to allow the refrigerator to move out from the wall after installation.

7 CONNECT THE TUBING TO THE VALVE

Place the compression nut and ferrule (sleeve) for copper tubing onto the end of the tubing and connect it to the shutoff valve. Make sure the tubing is fully inserted into the valve. Tighten the compression nut securely.

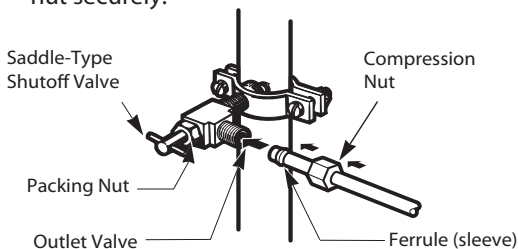

8 FLUSH OUT THE TUBING

Turn the main water supply on and flush out the tubing until the water is clear.

Shut the water off at the water valve after about one quart of water has been flushed through the tubing.

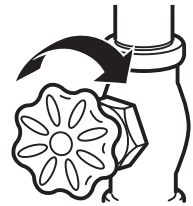

9 CONNECT THE TUBING TO THE REFRIGERATOR

NOTE: Before making the connection to the refrigerator, be sure that the refrigerator power cord is not plugged into the wall outlet.

- a. Remove the plastic flexible cap from the water valve.
- b. Place the compression nut and ferrule (sleeve) onto the end of the tubing as shown.
- c. Insert the end of the copper tubing into the connection as far as possible. While holding the tubing, tighten the fitting.

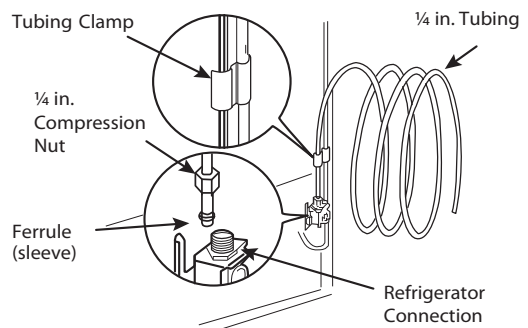

! NOTE

Never use old or used hoses. Always use new ones to have a better use and experience. Connect always to a potable water source to avoid security and health issues.

- 10 TURN THE WATER ON AT THE SHUTOFF VALVE
Tighten any connections that leak.

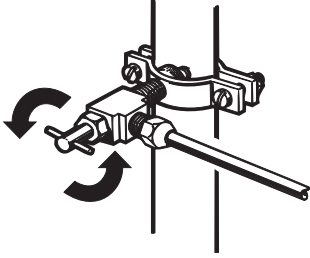
**CAUTION**

Check to see if leaks occur at the water line connections.

- 11 PLUG IN THE REFRIGERATOR

Arrange the coil of tubing so that it does not vibrate against the back of the refrigerator or against the wall. Push the refrigerator back to the wall.

- 12 START THE ICEMAKER

Set the icemaker power switch to the ON position.

The icemaker will not begin to operate until it reaches its operating temperature of 15°F (-9°C) or below. It will then begin operation automatically if the icemaker power switch is in the ON (I) position.

Turning On The Power

- 1 Plug in the refrigerator.

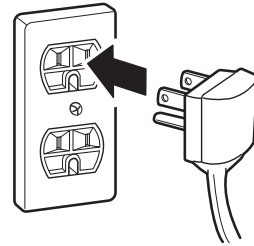
**CAUTION**

- Connect to a rated power outlet.
- Have a certified electrician check the wall outlet and wiring for proper grounding.
- Do not damage or cut off the ground terminal of the power plug.

Leveling and Door Alignment

Leveling

After installing, plug the refrigerator's power cord into a 3-prong grounded outlet and push the refrigerator into the final position.

Your refrigerator has two front leveling legs—one on the right and one on the left. Adjust the legs to alter the tilt from front-to-back or side-to-side. If your refrigerator seems unsteady, or you want the doors to close more easily, adjust the refrigerator's tilt using the instructions below:

- 1 Turn the leveling leg to the left to raise that side of the refrigerator or to the right to lower it. It may take several turns of the leveling leg to adjust the tilt of the refrigerator.

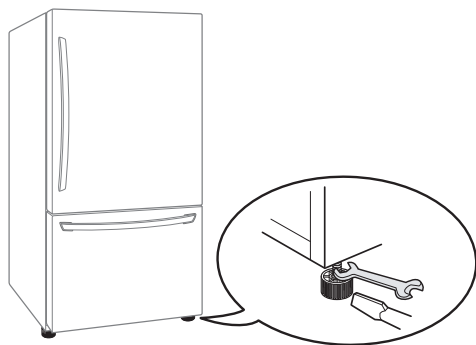

! NOTE

A flare nut wrench works best, but an open-end wrench will suffice. Do not over-tighten.

- 2 Open the doors again and check to make sure that they close easily. If the doors do not close easily, tilt the refrigerator slightly more to the rear by turning both leveling legs to the left. It may take several more turns, and you should turn both leveling legs the same amounts.

Door Alignment

If the space between your doors is uneven, follow the instructions below to align the doors.

- 1 Remove the top hinge cover screws.
Lift the hook located at the bottom of the front side of the cover with a flat-head screwdriver.
- 2 Loosen the top hinge bolts using a 10mm or 13/32 in. socket wrench or open-end wrench.
- 3 Have someone hold the refrigerator door so the space between the two door is even, and retighten the top hinge bolts.
- 4 Replace the top hinge cover.