

Job Name:	
Submitted By:	



**Submittal Sheet For: CK018GMSILDFHG / YN018GMSI24RPG**

Date \_\_\_\_\_  
 Ref. \_\_\_\_\_

**One-Way Ceiling Cassette 22SEER Inverter Heat Pump**

System Full Set Model: **CYK018GMSI24RL**

AHRI Reference Number: **218010988**

**Cooling Mode Performance**

Rated Cooling	18,000 BTU/hr
Ambient Range	5~131°F
SEER2 Rating	22.2 BTU/W·h
EER2 Rating	12.5 BTU/W·h

\* 100% Capacity @ Indoor DB 80°F / WB 67°F

**Heating Mode Performance**

Rated Heating	18,000 BTU/hr
Ambient Range	-13~86°F
HSPF2 IV (V)	12.2 (8.6) BTU/W·h
COP2 (47°F)	3.3 W/W

Heating (17°F) = 14,000 BTU / Heating (5°F) = 13,100 BTU / COP2 (5°F) = 2.24 W/W



One-Way Cassette Indoor Unit

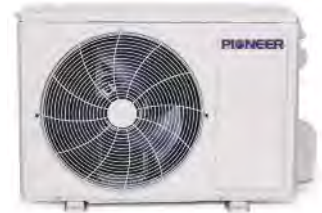

Outdoor Condensing Unit



User-Selected Installation Kit



Handheld Remote Controller

**Electrical Information**

Rated Input (W)	Cooling	Heating
	1,440	1,600
Rated Current (A)	6.4	7.1
Breaker Needed	20A (Double-Pole)	
Power Supply	208~230V, 60Hz, 1Ph	

**Piping and Refrigerant**

Liquid Line (OD)	1/4 in
Suction Line (OD)	1/2 in
Refrigerant Precharge	R-454b(Supports 10-50 ft.)
Max Length/Height Diff.	100 ft. / 65 ft.

This combination is Energy-Star certified.



**Interior Unit (Air Handler) Specifications**

Type	Heat Pump
Sound Level (dBA)	48(Turbo)/44(Hi)/41(Med)/30(Lo)/24(Mute)
Auto Air Circulation	1-Way Louver (Auto Up-Down Swing)
Dimensions (WDH)	50-3/8 in x 13-1/4 in x 10 in
Weight (lbs)	45.5

**Exterior Unit (Condenser) Specifications**

Sound Level (dBA)	58
Recommended Room Size	500~750 Sq. ft.
Minimum Room Size	54 Sq. ft.
Compressor	Inverter-Driven Rotary
Dimensions (WDH)	35 in x 13-1/2 in x 26-1/2 in
Weight (lbs)	92.6

# CK018GMSILDFHG Air Handler Dimensional Data

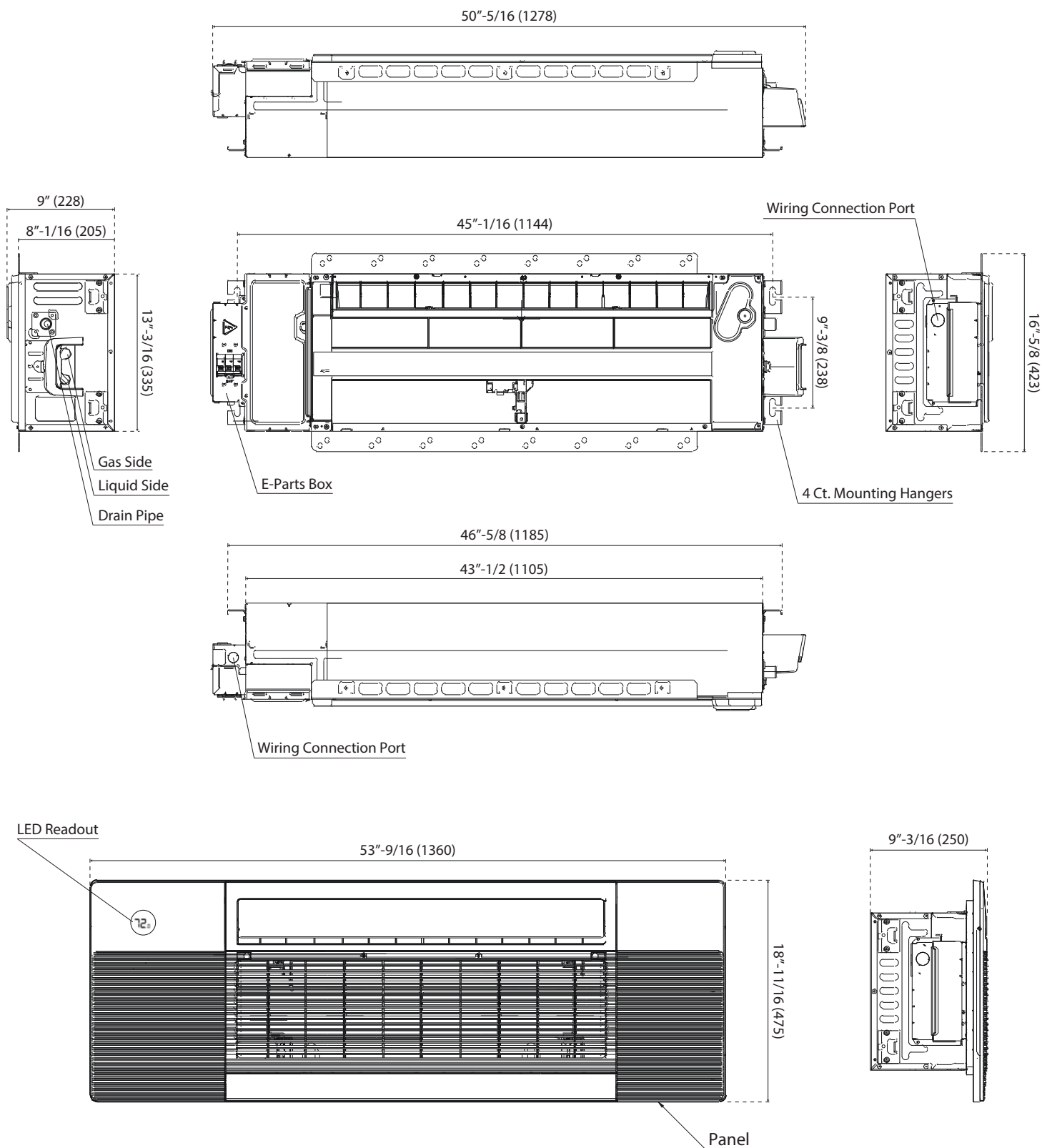

All dimensions are in Inches (mm)

# YN018GMSI24RPG Condenser Unit Dimensional Data

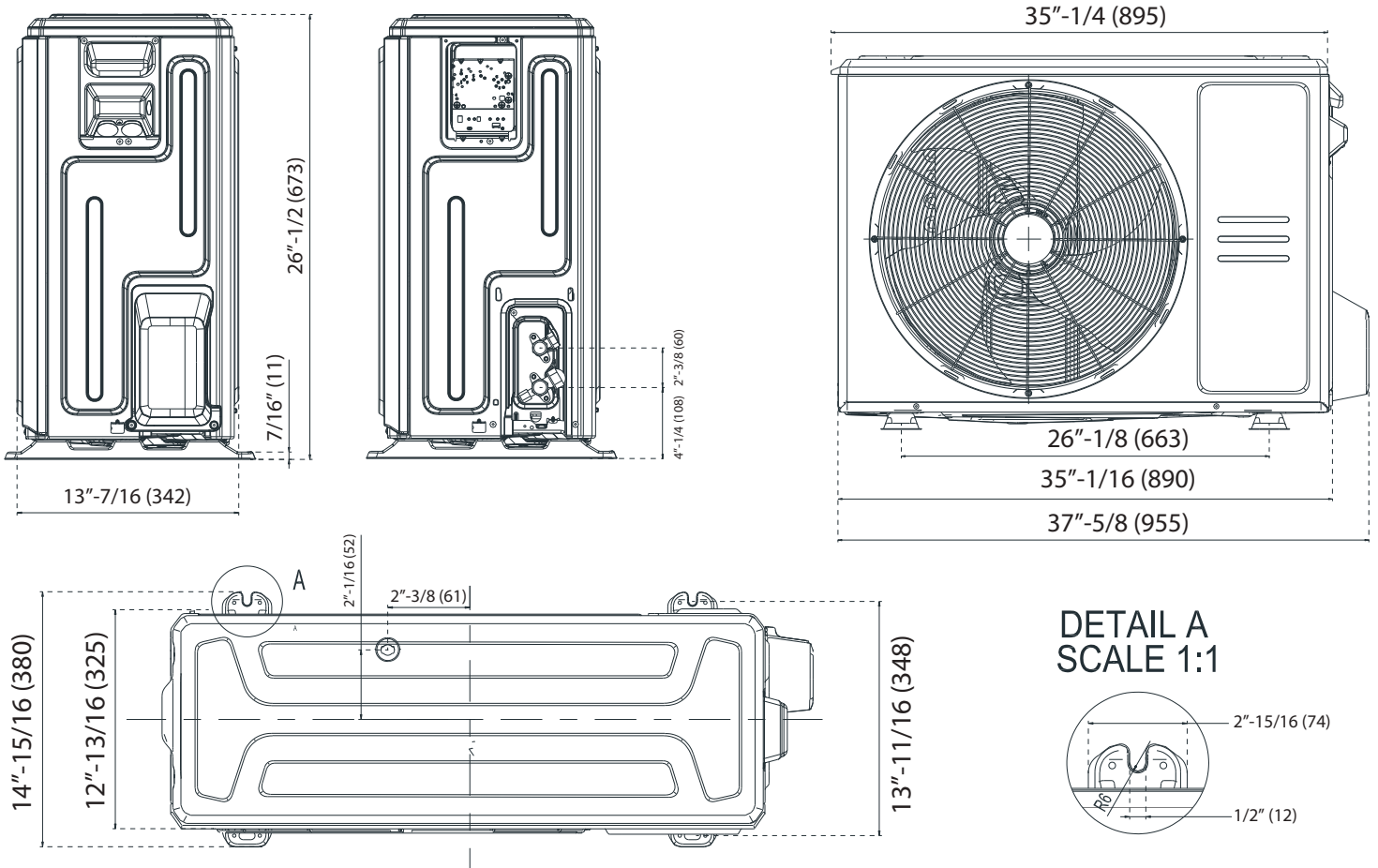

## Warranty Information and Length



Complete warranty details are available with the vendor or online at <https://www.pdhvac.com/support/warranty/>. This high quality system is eligible for up to 10 years limited warranty on the compressor, and 7 years on other internal parts. To qualify for this warranty, the system must be installed within 90 days by a registered technician. All other installations that are registered default to 5 years parts/compressor. Products unregistered qualify for only 1 year parts/compressor warranty.

## Outstanding Features

- LED Display
- Energy Saving
- Ultra-Thin Design
- Dual Drain Options
- Customizable Timer
- Eco-Friendly Refrigerant
- Whisper-Quiet Operation
- Power Loss Memory Recovery



## Available Accessories

Part Number	Description
IKT-LCVR4P-KIT	Decorative PVC Line Cover Kit
IKT-LNBR-1/4-3/8	BendAid Flexible Easy Bender Kit
BRK-FRM-C-2P	Folding Mounting Bracket w/ Leveler
IKT-UVL32UL-AG	UVC Bacterial Disinfection Kit
IKT-SURPRK-DV2	Ultimate Surge and Power Protection