

# OpenDots 2

## User Guide

SHOKZ E320

# App



## Download the Shokz App

Enable Dolby Audio, Multipoint Pairing, and EQ switching. Customize gesture controls, use Find My Earbuds, and keep your device current with firmware updates.

\*APPLE AND THE APPLE LOGO ARE TRADEMARKS OF APPLE INC., REGISTERED IN THE U.S. AND OTHER COUNTRIES. GOOGLE PLAY IS A TRADEMARK OF GOOGLE LLC.

# Catalogue

<b>WHAT'S IN THE BOX</b>	03
<b>WEAR AND USE</b>	05
Earbud Diagram	06
Charging Case	07
Bluetooth Pairing Instructions	08
Wearing Instructions	10
<b>TOUCH CONTROL INSTRUCTIONS</b>	13
Audio Control	15
Call Management	16
<b>CHARGING</b>	17
Power On/Off, and Standby Mode	18
Charging the Earbuds	20
Charging the Charging Case	21

<b>CHARGING CASE INDICATOR</b> .....	22
<b>OTHER SHOKZ APP FUNCTIONS</b> .....	25
Upgraded Dolby Audio .....	26
EQ Adjustments .....	27
MultiPoint Pairing .....	28
Interchangeable Left/Right Earbuds .....	30
Wear Detection .....	31
Adjusting the Volume of the Prompt Sounds .....	32
Auto Reconnect .....	33
Find My Earbuds .....	34
Resetting the Earbuds .....	35
<b>CLEANING &amp; MAINTENANCE</b> .....	36
Cleaning .....	37
IP Rating .....	38
Storage and Maintenance .....	39
<b>AFTER-SALES SERVICE</b> .....	40
Serial Number Location .....	41
Warranty .....	42

# WHAT'S IN THE BOX

# What's in the Box

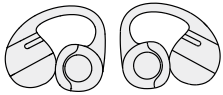

OpenDots 2  
Clip-On Earbuds \*2

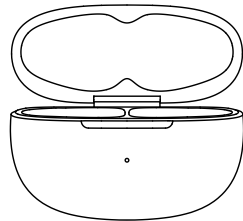

OpenDots 2  
Charging Case \*1



USB-C  
Charging Cable \*1

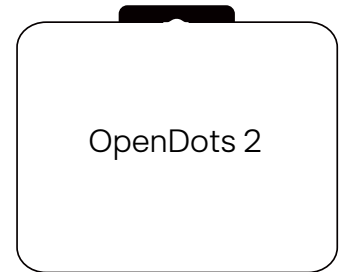

OpenDots 2  
Packaging Box \*1

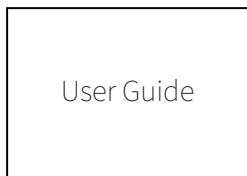

User Guide \*1

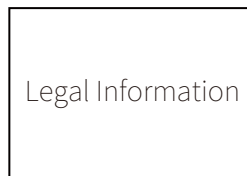

Legal  
Information \*1

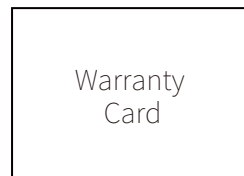

Warranty  
Card \*1

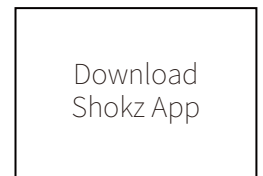

App Card \*1

If any of the above-listed items are missing or the product is damaged, do not use it. Please contact the dealer where the product was purchased or reach out to us.

(Refer to page 42: After-Sales Service – Contact Us)

# WEAR AND USE

# Earbud Diagram

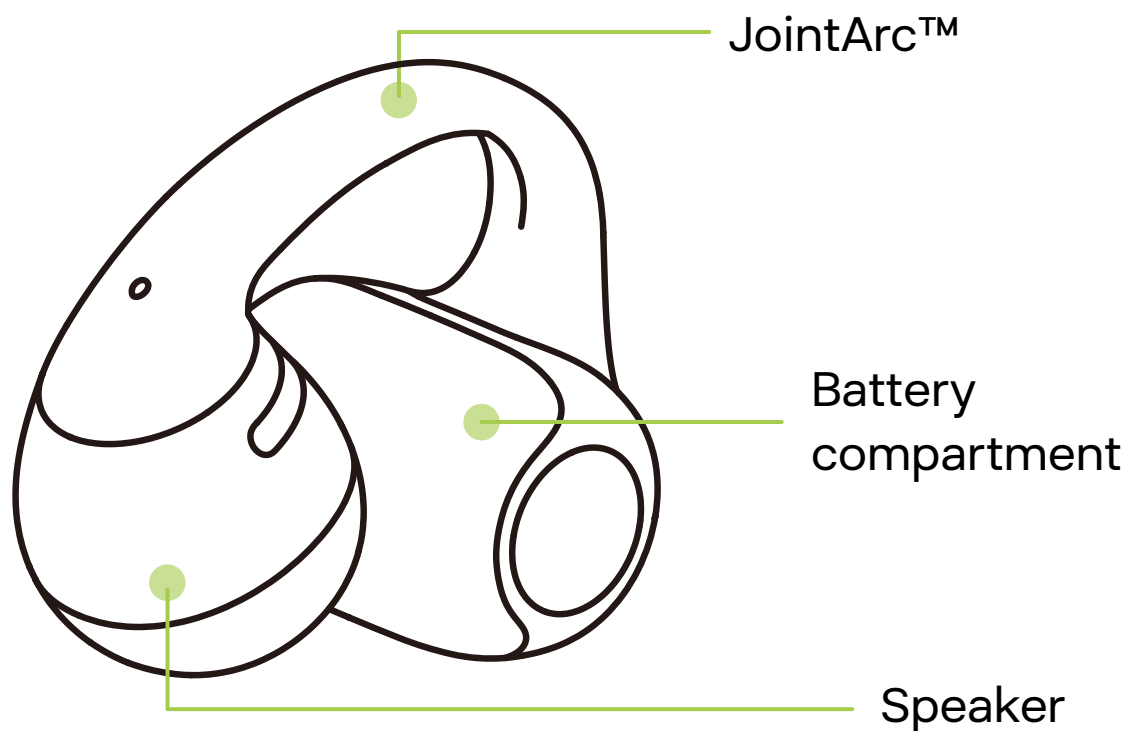

These open-ear earbuds sit outside the ear canal. The symmetrical design allows for interchangeable left/right wear with automatic audio channel adjustment.

# Charging Case

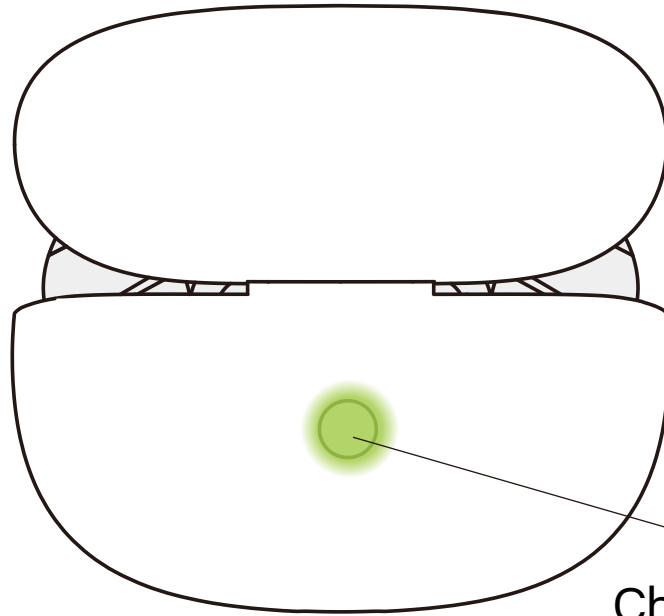

Charging Case Button

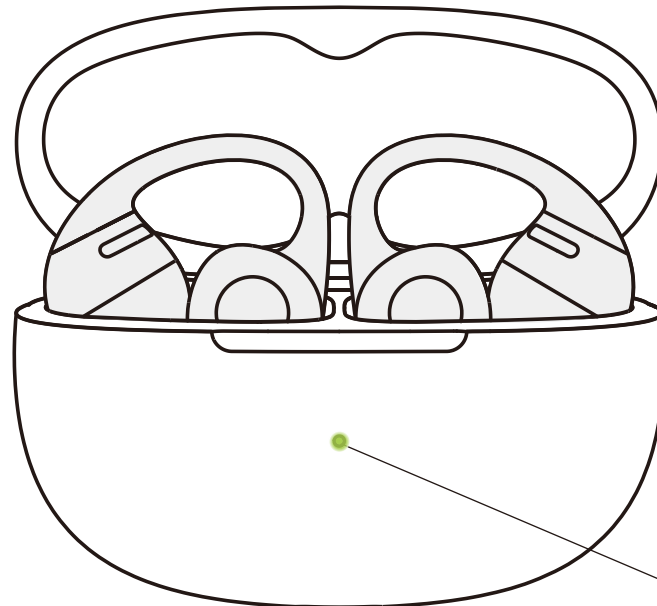

Charging Case  
Indicator LED

# Bluetooth Pairing Instructions

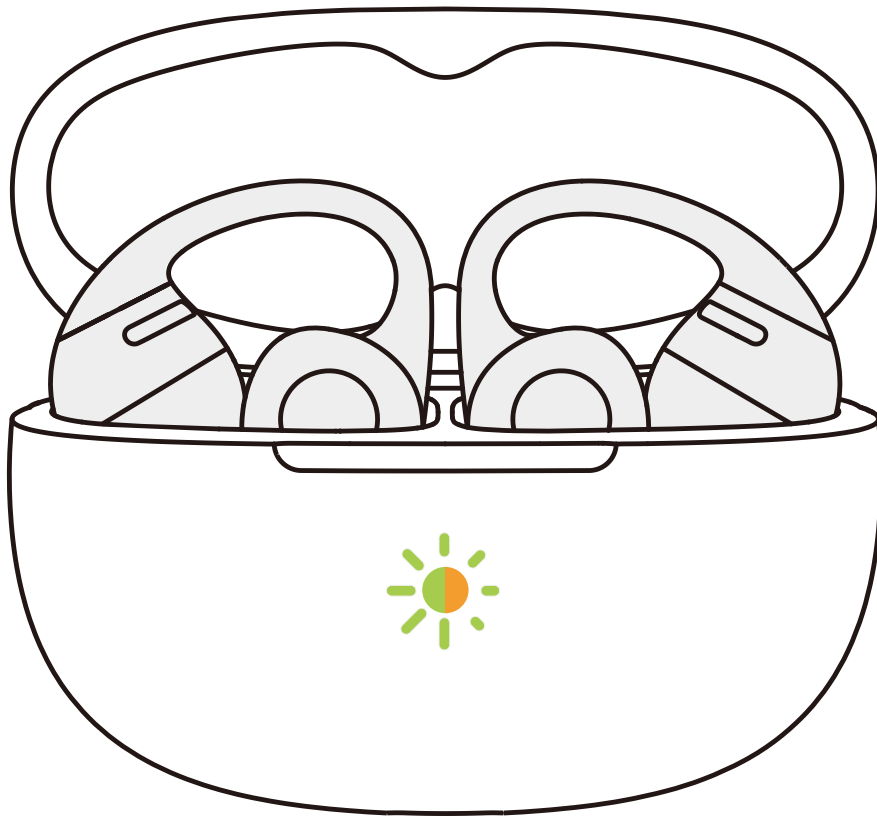

For first-time use, open the charging case to automatically enter Bluetooth pairing mode. The indicator light inside the case will flash orange and green. To re-pair the earbuds, follow these steps:

1. Place both earbuds back into the charging case.
2. With the case lid open, press and hold the function button for more than 3 seconds until the indicator light flashes orange and green. The earbuds will enter pairing mode.

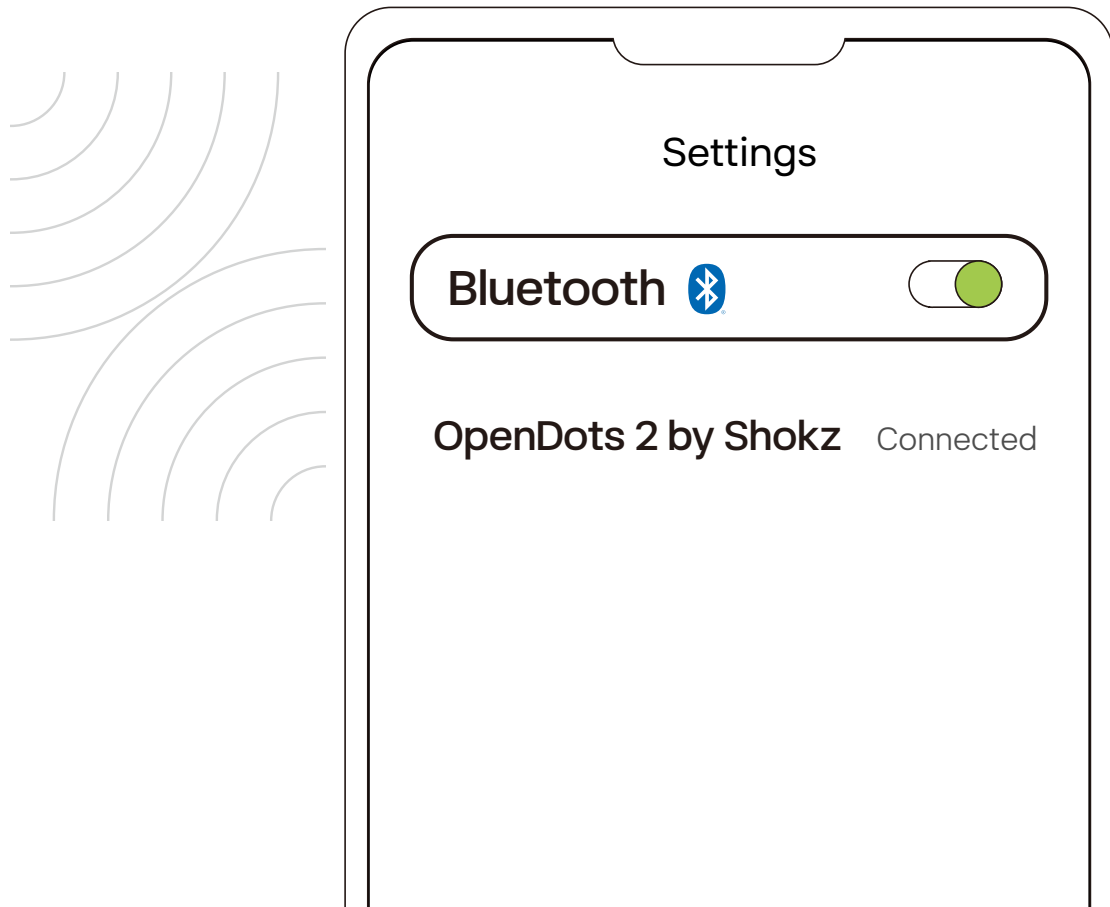

3. Turn on the Bluetooth function on your device and select "OpenDots 2 by Shokz". Once your device displays a successful pairing message, the connection is complete.

\*After the earbuds are connected to your phone, they will automatically power on and reconnect whenever you open the charging case. Closing the case will automatically power off the earbuds and disconnect them from the phone.

\*Note: If the earbuds disconnect due to exceeding the Bluetooth range, they will automatically reconnect once they return within range. Simply perform any touch control to trigger reconnection.

# Wearing Instructions

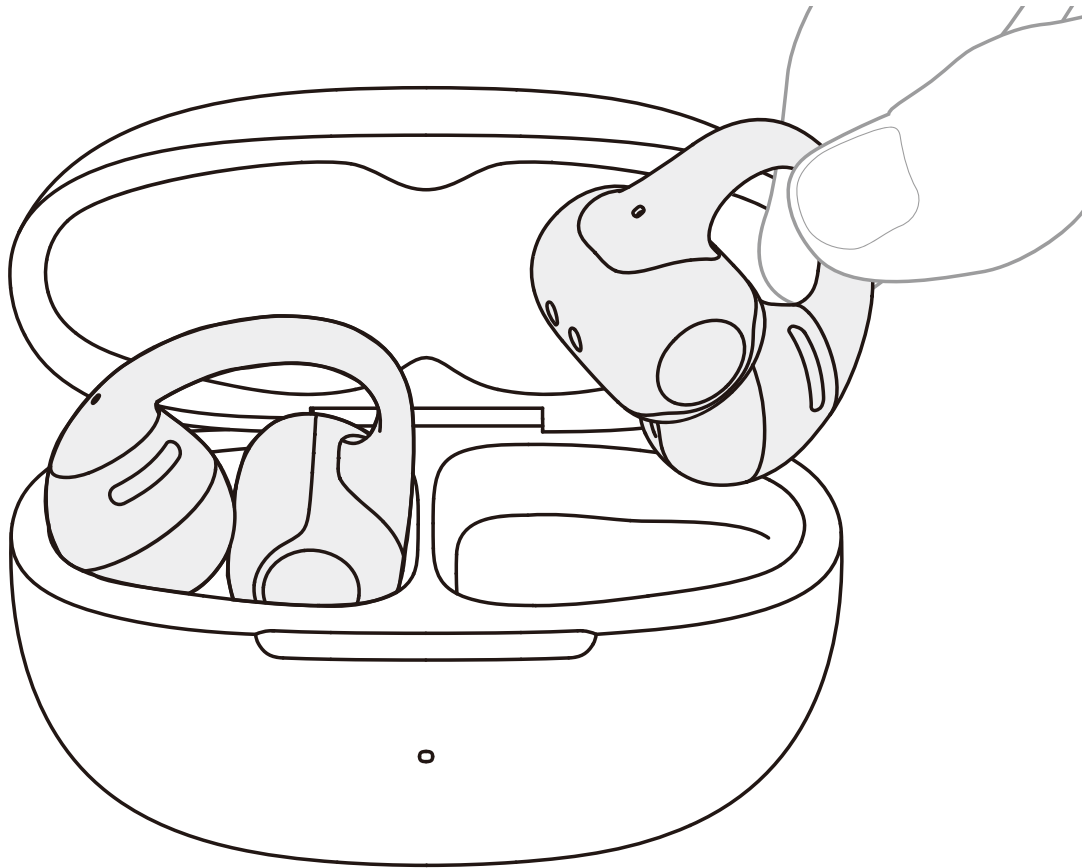

1. Pinch the JointArc™ with your thumb and forefinger and raise it toward your ear.

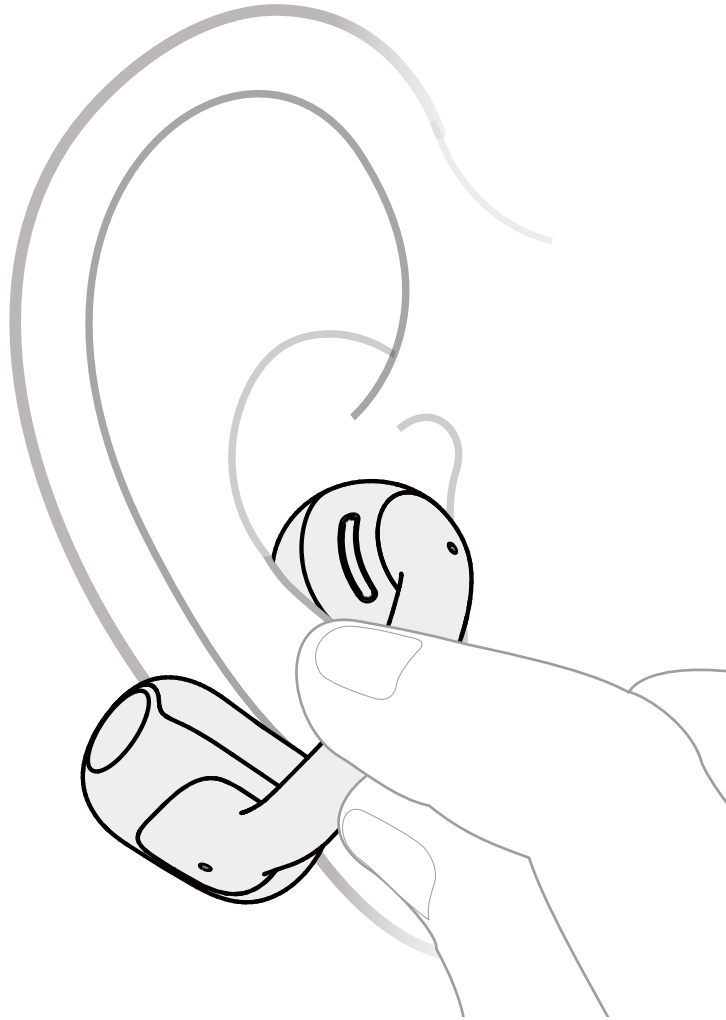

2. Place the round speaker unit against the inner ridge of your ear. Rest the battery compartment behind your ear.

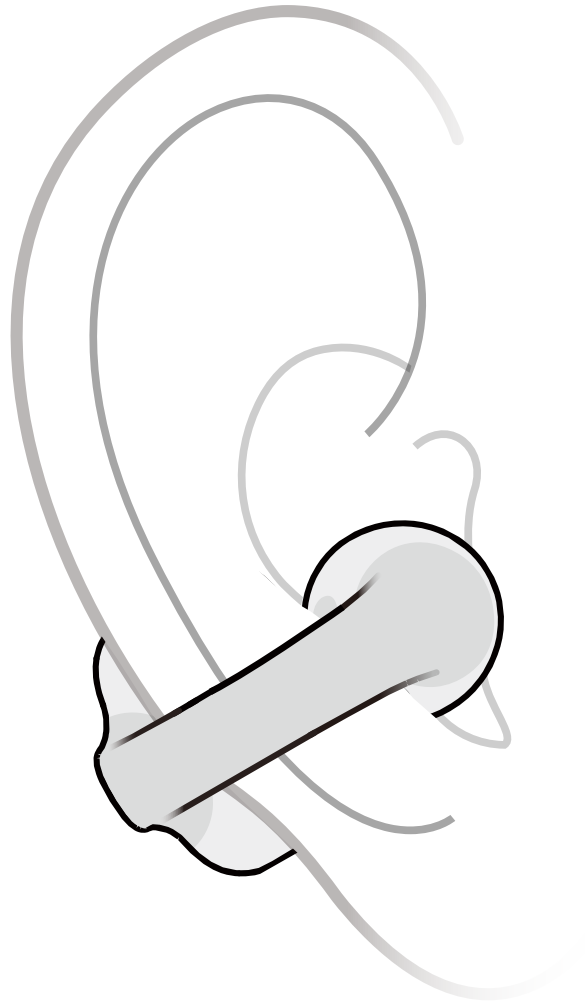

3. Adjust the earbuds for a secure and comfortable fit. For optimal stability, we recommend angling the JointArc™ slightly downward ( $0^{\circ}$  to  $30^{\circ}$ ).

**Avoid These Common Mistakes:**

**Positioning:** Ensure the round speaker sits in front of the ear canal—do not insert it.

**Angle:** Keep the JointArc™ at a natural angle; avoid positioning it too high or low.

**Handling:** Do not pull, twist, or bend the earbuds with excessive force.

# TOUCH CONTROL INSTRUCTIONS

# Touch Control Instructions

## Single-finger tap

Tap any area of the JointArc or battery compartment with one finger.

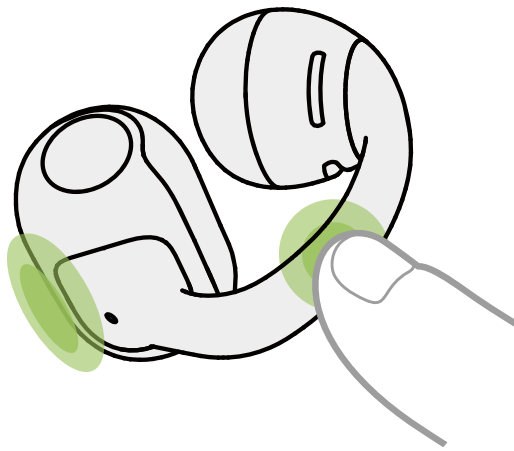





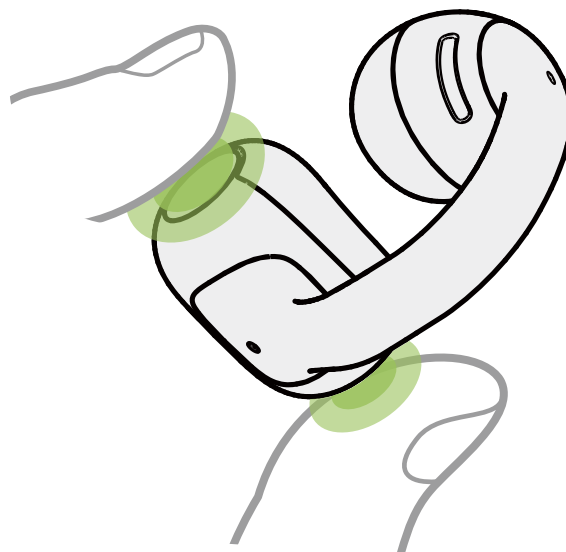







## Two-finger pinch



Gently pinch both ends of the battery compartment with two fingers simultaneously.



# Audio Control

	Functions	Gestures
	 Play/Pause	<ul style="list-style-type: none"> <li>• Pinch ×1 </li> </ul> <hr/> <ul style="list-style-type: none"> <li>• Tap ×2 </li> </ul>
	 Volume -	<ul style="list-style-type: none"> <li>• L Pinch and hold </li> </ul>
	 Volume +	<ul style="list-style-type: none"> <li>• R Pinch and hold </li> </ul>
	 Previous track	<ul style="list-style-type: none"> <li>• L Pinch ×2 </li> </ul>
	 Next track	<ul style="list-style-type: none"> <li>• R Pinch ×2 </li> </ul>

# Call Management

	Functions	Gestures
	 Answer/Hang up	• <b>Pinch ×1</b> ●
	 Reject	• <b>Pinch ×2</b> ● ●

## Advanced Call Management

When receiving a second call, you can:

Answer and hold the current call: Pinch either earbud x1

After answering, you can:

Place on hold and switch calls: Pinch either earbud x1

End current call and switch to call on hold: Pinch either earbud x2

Reject the new call: Pinch either earbud x2

End current call and answer incoming call: Pinch and hold either earbud

# CHARGING

# Power On/Off, and Standby Mode

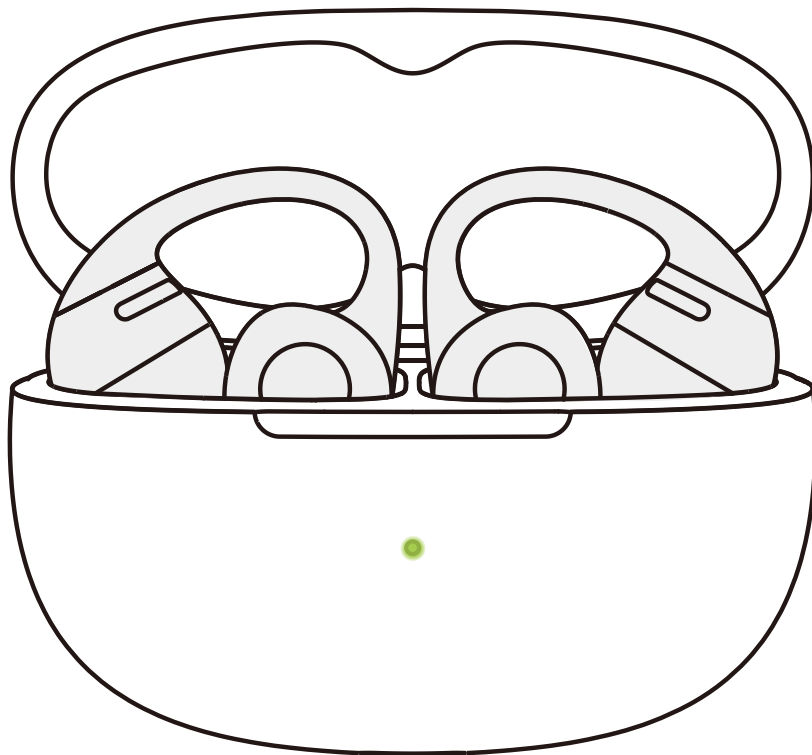

## 1. Power On

When the earbuds are inside the charging case, opening the case will automatically power them on, and the case indicator light will turn on.

Note: After removing the earbuds from the case, closing the charging case helps preserve battery life and prevents debris from entering the case.

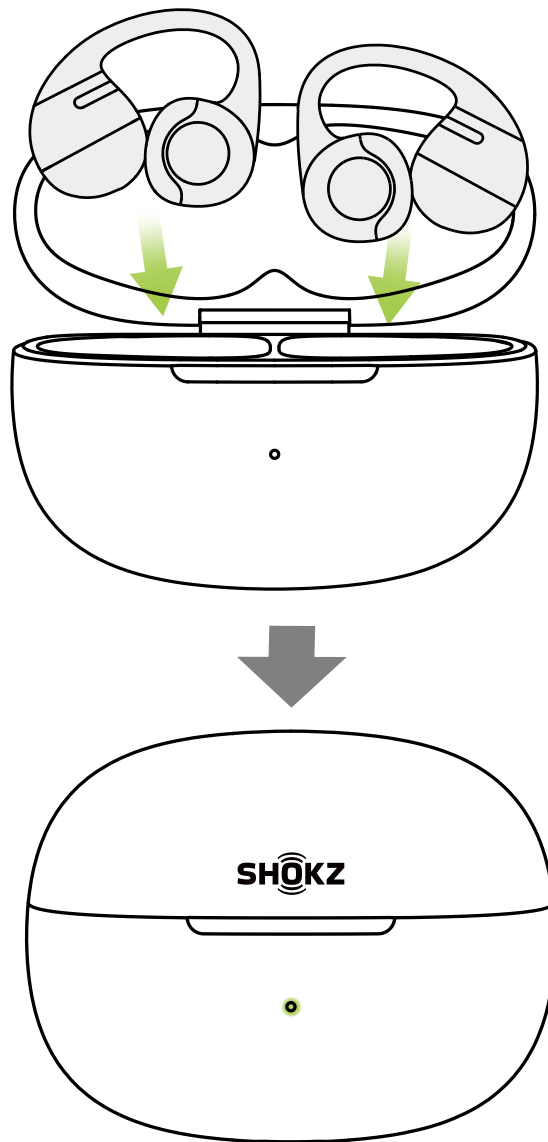

## 2. Power Off

Place both earbuds back into the charging case and close the lid. The earbuds will automatically power off.

## 3. Standby Mode

If the earbuds are outside the charging case and remain unconnected to a device for 3 minutes, they will switch to standby mode to conserve battery power.

# Charging the Earbuds

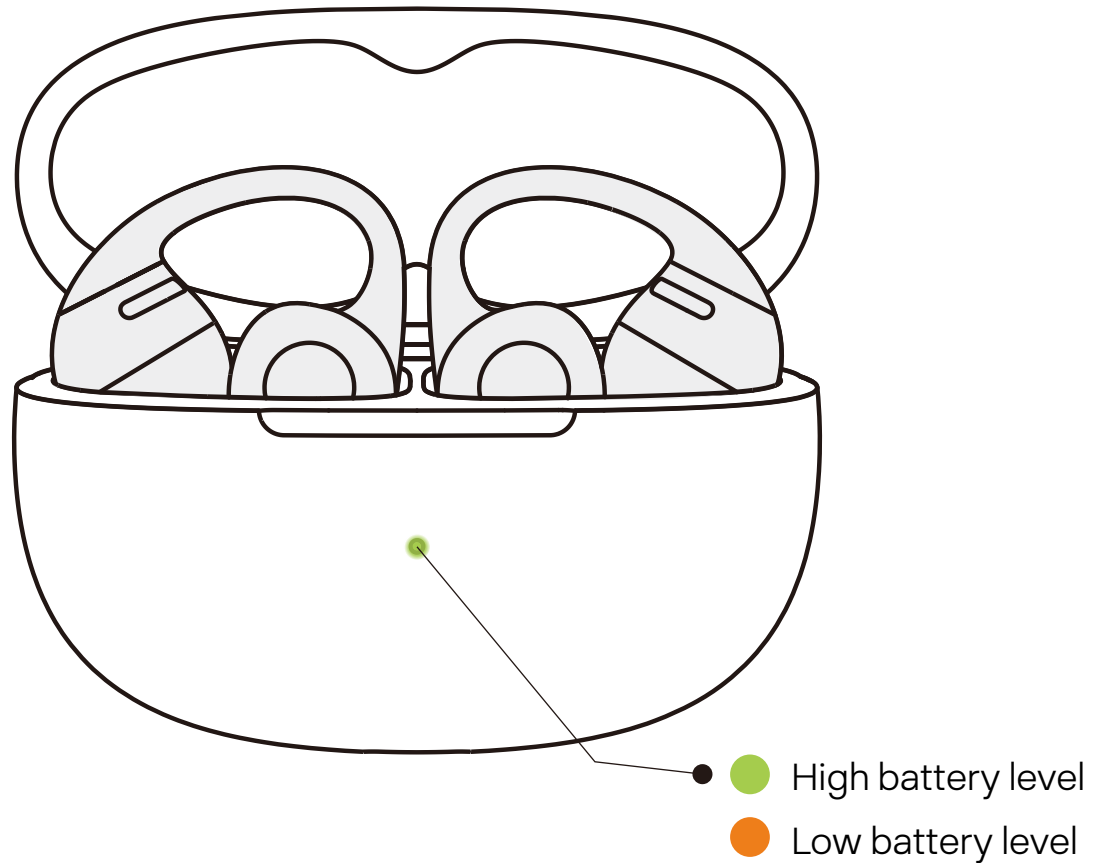

Place the earbuds into the charging case until they are magnetically secured in place. The charging case indicator light will turn on, and you can then close the case.

**\*Note:**

1. The indicator light on the charging case shows the battery status of the earbuds inside. A green light indicates a battery level higher than 80%, while an orange light indicates a level lower than 80%. If both earbuds are in the case, the light will display the battery level of the earbud with the lower charge.
2. The earbuds will be fully charged after approximately 60 minutes in the case. Ensure the charging case has enough battery to charge the earbuds.

# Charging the Charging Case

- Orange light on the charging case

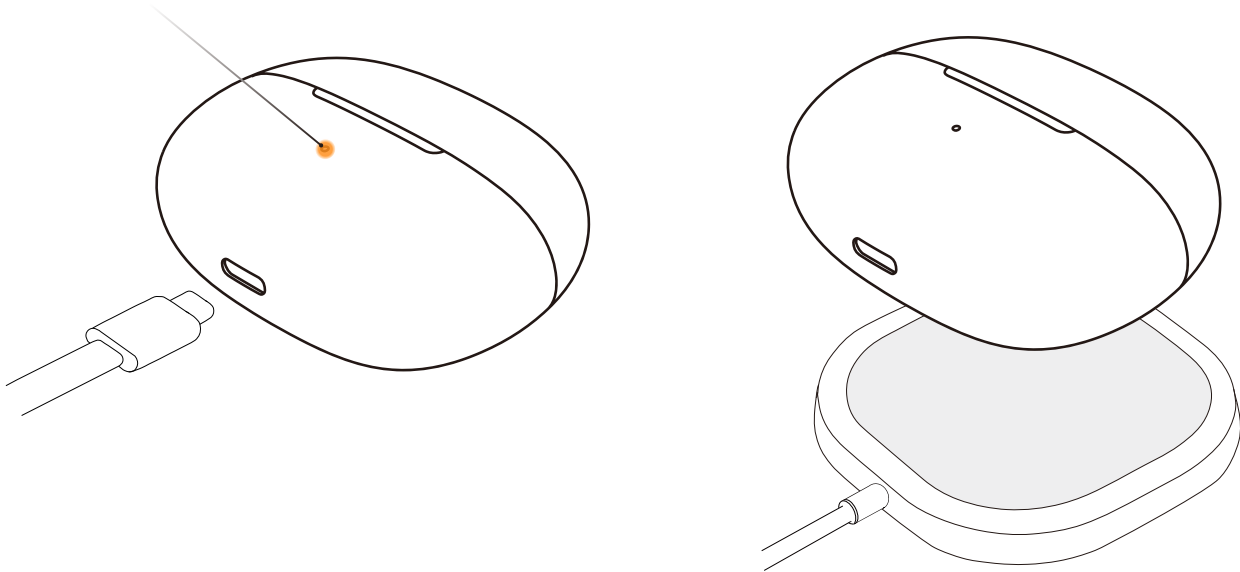

Insert the provided USB-C to USB-C charging cable into the charging case and connect it to a USB-C power source or certified wall charger. Alternatively, place the charging case on a certified wireless charger to charge it.

During charging, the orange light on the outside of the case will remain on, indicating that the case is charging. When the light turns green and remains on, the charging case is fully charged.

**\*Note:**

1. When charging via cable, it takes approximately 2 hours to fully charge the case. The charging case uses a standard  $5V \pm 5\%$  USB voltage. It is not recommended to use a power source with a higher voltage for charging the case. Using third-party charging cables may extend the charging time. Before charging, ensure the charging port is dry and free from sweat or other liquids. If there is liquid in the port, wipe it clean with a soft, dry cloth.
2. When charging wirelessly, the case fully charges in approximately 4 hours. If the case has a silicone protective cover, wireless charging may take longer. Before charging, ensure the case is positioned in the center of the wireless charger. If the case is not aligned properly, charging may fail.

# CHARGING CASE INDICATOR

# Charging Case Indicator

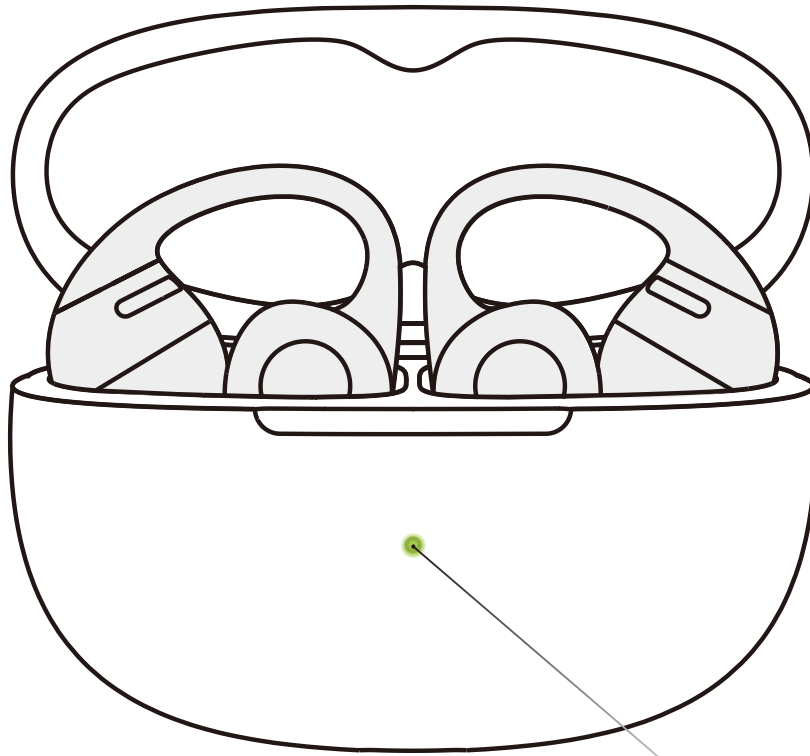

Charging Case Indicator

## 1. Battery Status of Earbuds in the Charging Case

When the earbuds are in the charging case, the indicator light shows the battery status of the earbuds:

Battery above 80%	Open the charging case, and the green light will remain on for 5 seconds before turning off.
Battery below 80%	Open the charging case, and the orange light will remain on for 5 seconds before turning off.

\*Note: If both earbuds are in the case, the indicator light will display the battery level of the earbud with the lower charge.

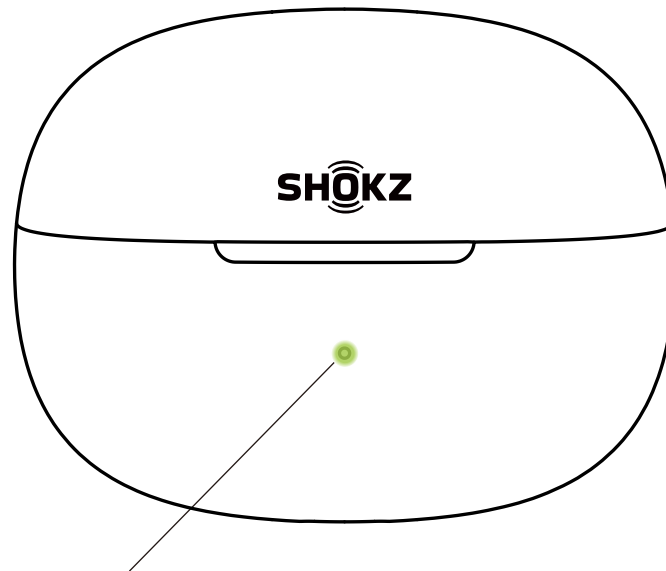

Charging Case Indicator

## 2. Both Earbuds Outside the Charging Case, Not Connected to External Power

When both earbuds are outside the charging case and not connected to an external power source, the indicator light shows the battery status of the charging case:

Battery above 40%	When opening/closing the charging case or pressing the case button, the green light will remain on for 5 seconds before turning off.
Battery below 40%	When opening/closing the charging case or pressing the case button, the orange light will remain on for 5 seconds before turning off.

## 3. Connected to External Power Source

Charging	The orange light remains on.
Charging Complete	The green light remains on.

## 4. Other

Pairing	The orange and green lights flash alternately.
Reset to Factory Settings	The orange light flashes for 5 seconds before turning off.

# OTHER SHOKZ APP FUNCTIONS

# Upgraded Dolby Audio

1. Upgraded Dolby Audio: Enhanced with richer, thumping bass, your music gains new depth and impact while preserving the clear vocals, spacious soundstage, and lifelike detail you love. Turn Dolby Audio on or off in the Shokz App.
2. Before using, ensure the earbuds are connected to your phone and open the Shokz App.
3. Use the Dolby Audio switch to turn the feature on or off.

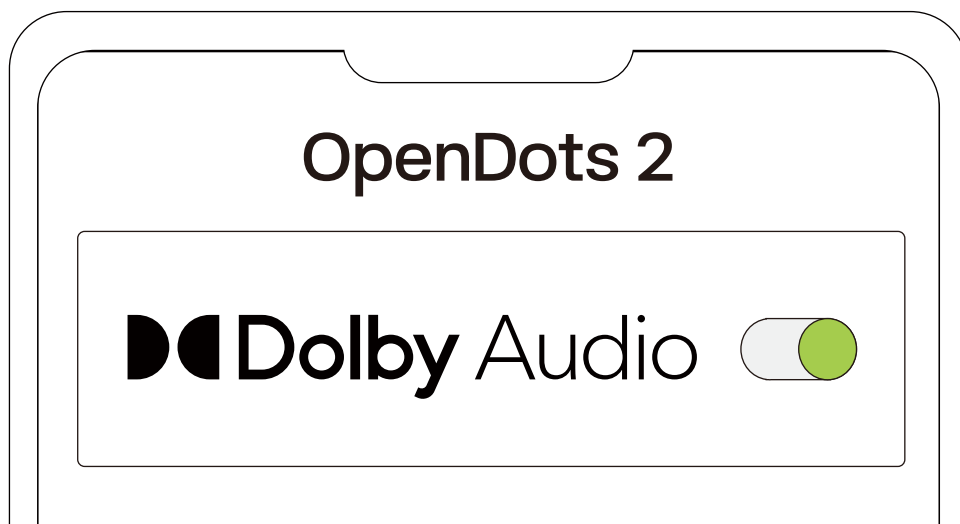

# EQ Adjustments

1. You can select different sound profiles or customize your own in the Shokz App.
2. Before using, ensure that your earbuds are successfully connected to your phone, then open the Shokz App.
3. In the sound profile options, select a preset mode to adjust.

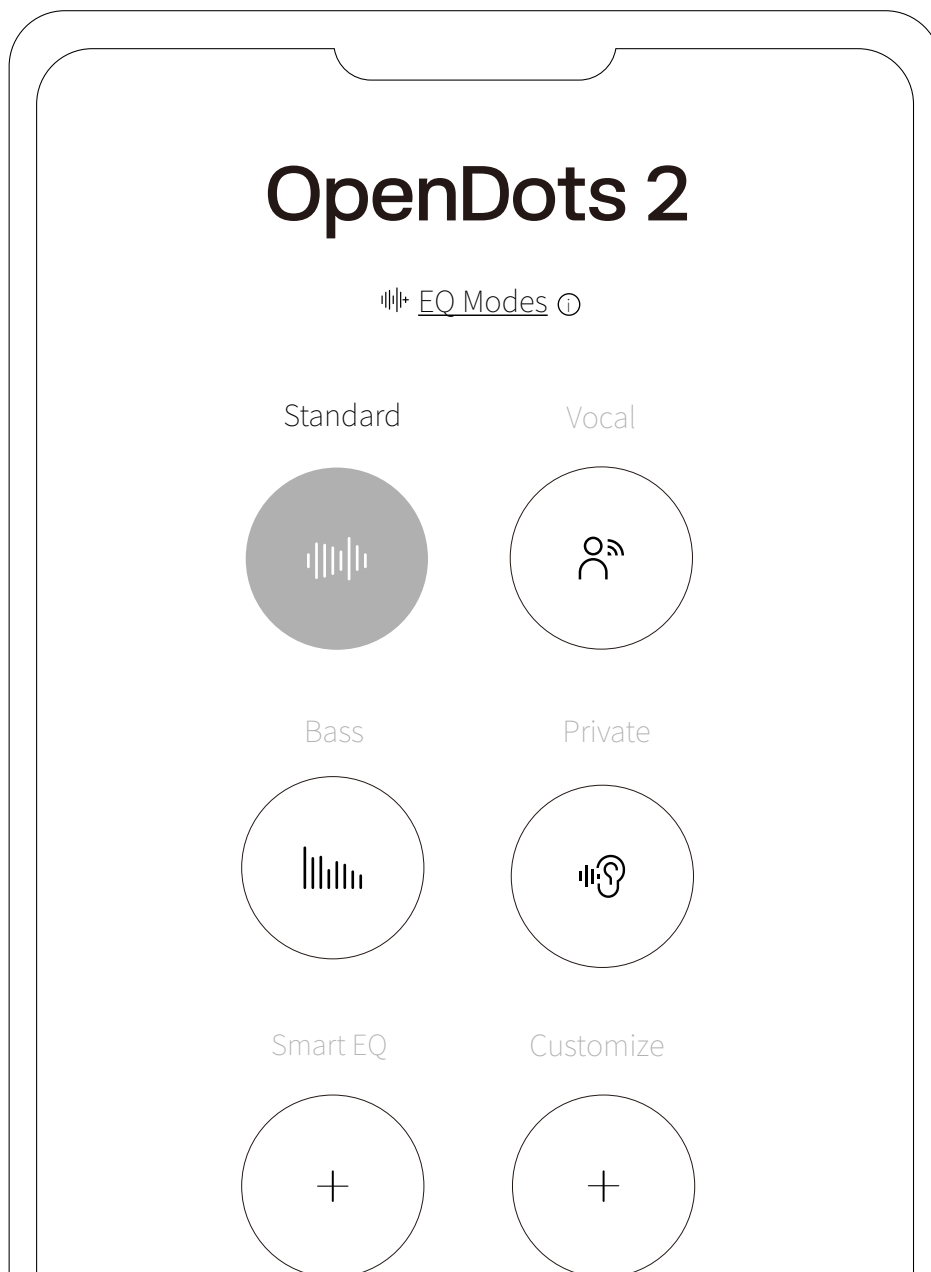

# MultiPoint Pairing

1. First, connect your earbuds to your phone, then select “Multi-Point Pairing” in the Shokz App.

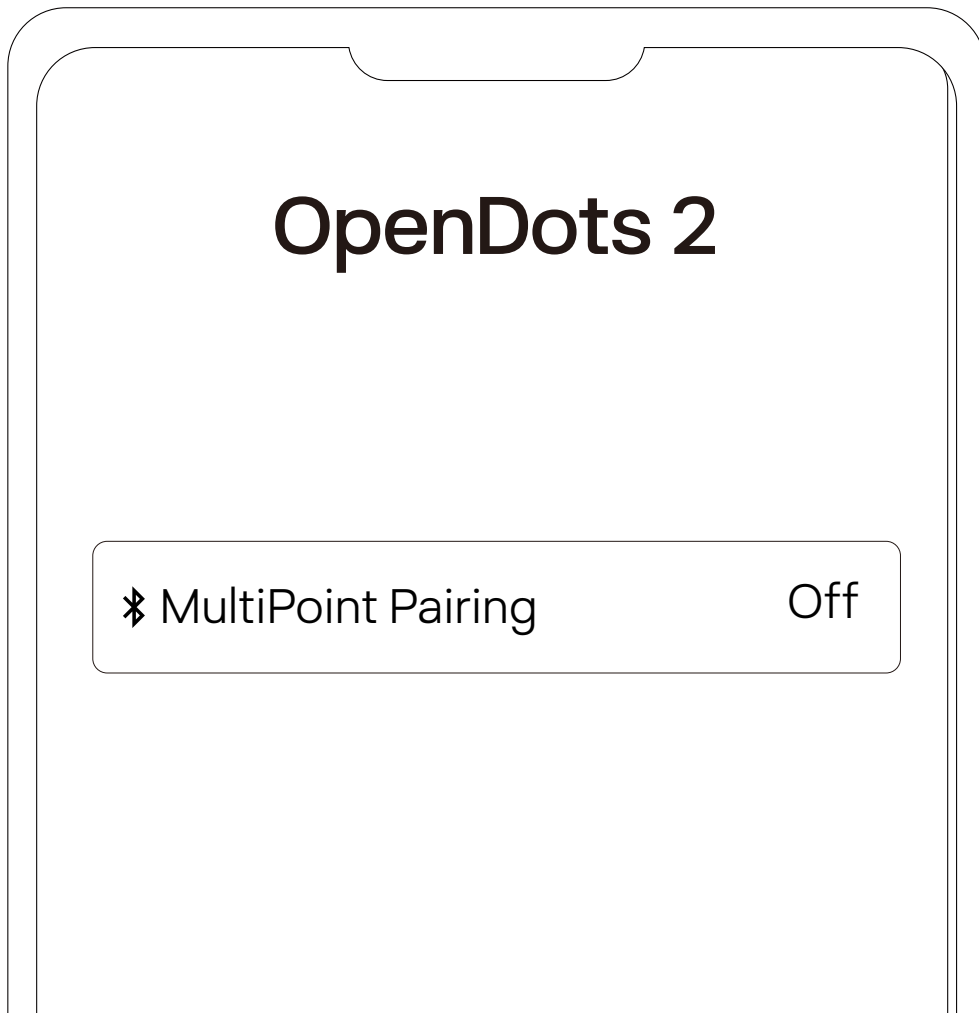

2. On the pop-up page, confirm that the MultiPoint Pairing feature is enabled.
3. Select “Connect to the Second Device” and follow the instructions to connect to the second device.

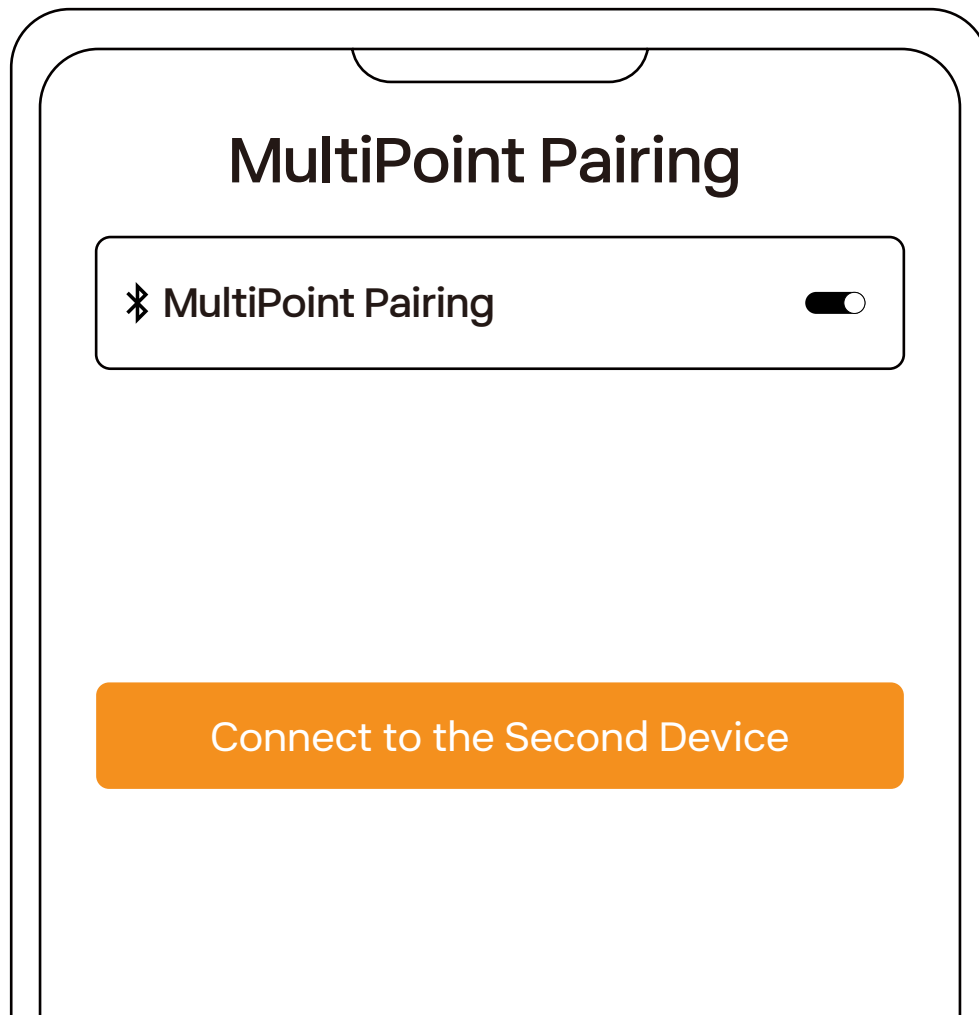

4. Your earbuds are now connected to two devices, and you can easily manage their Bluetooth connections through the Shokz App.

# Interchangeable Left/Right Earbuds

1. The earbuds do not require a specific left or right orientation. Once worn, the earbuds can automatically detect the fit and adapt to the left and right channels. You can enable or disable this feature in the Shokz App.

2. Ensure that your earbuds are successfully connected to your phone, then enable the "Interchangeable Left/Right Earbuds" toggle in the Shokz App.

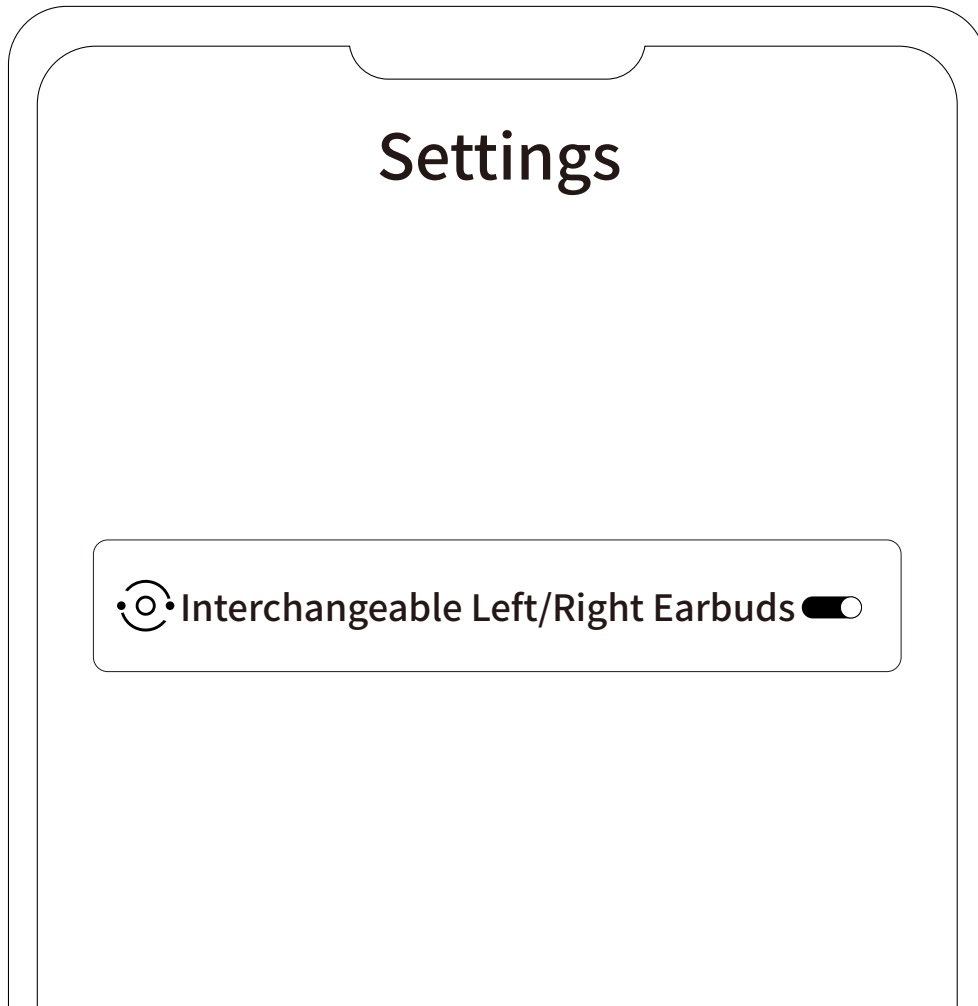

# Wear Detection

1. The earbuds can automatically detect whether they are being worn and will play or pause audio accordingly. You can enable or disable this wear detection feature in the Shokz App.
2. Before using, ensure that your earbuds are successfully connected to your phone, then open the Shokz App.
3. After opening the app, tap the settings icon (⚙️) in the top-right corner, then select "Settings" > "Smart Wear Detection" to toggle this feature on or off.

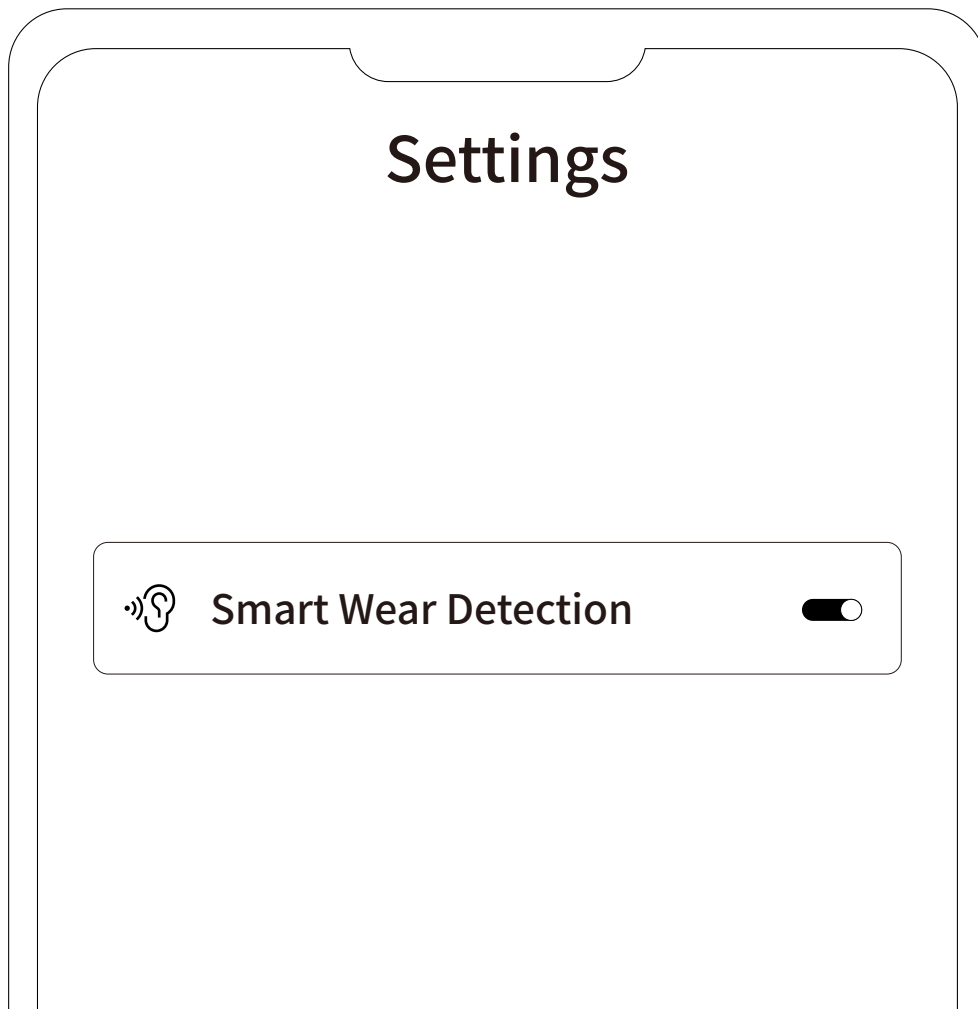

# Adjust the Volume of Prompt Sounds

1. Prompt sound volume can be adjusted in the Shokz App.
2. After opening the app, tap the settings icon (⚙️) in the top-right corner, then select "Settings" > "Prompt Settings" to adjust the volume to low, medium, or high.

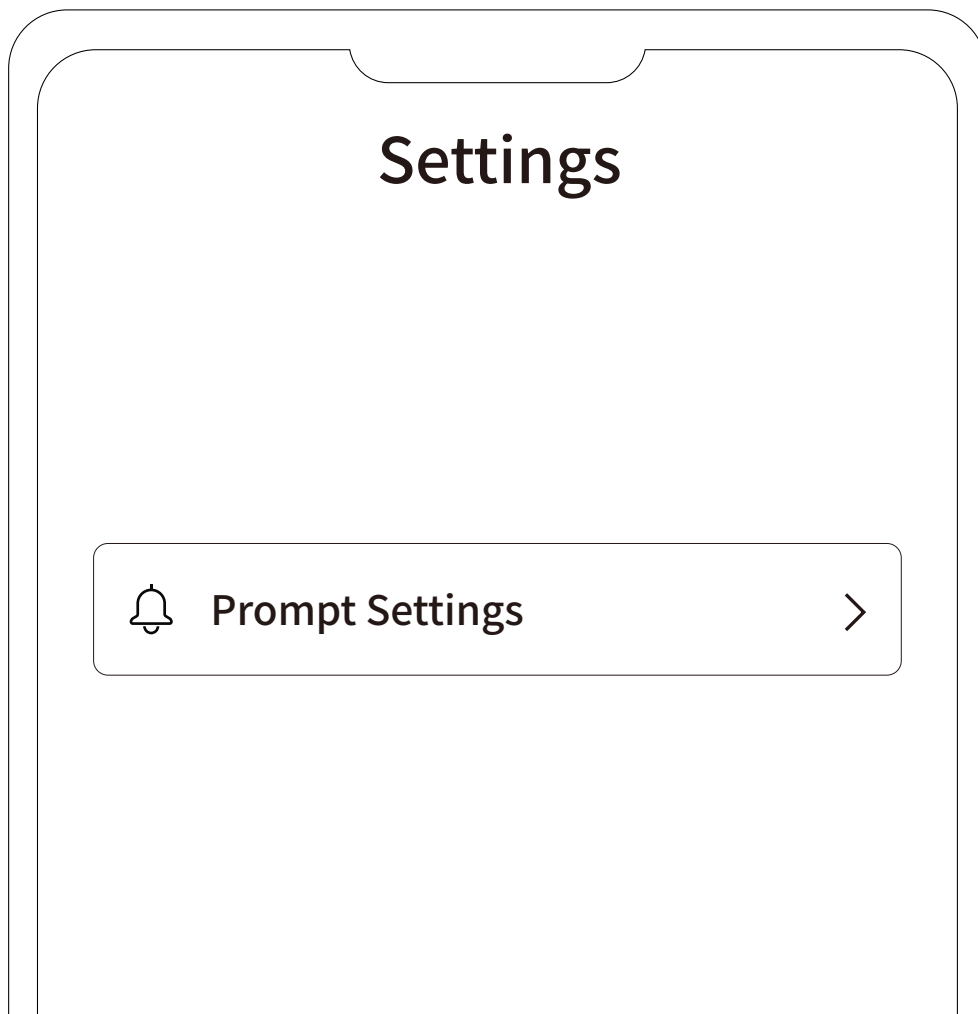

# Auto Reconnect

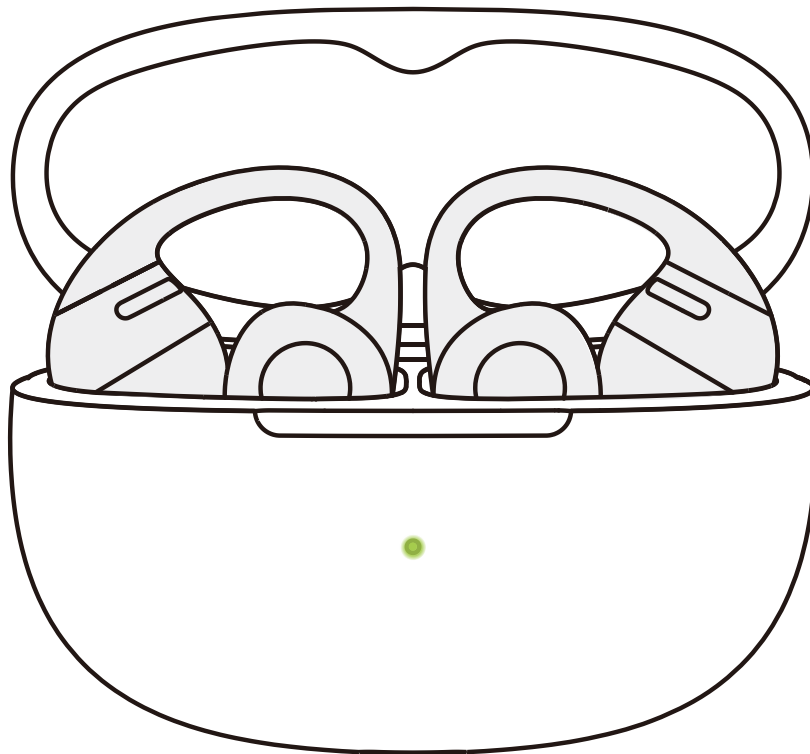

1. After powering on, the earbuds will automatically attempt to connect to the most recently connected device. A prompt sound will indicate a successful connection.
2. If the earbuds are disconnected from the device due to distance, and return within connection range (10m) within 3 minutes, they will automatically reconnect to the last paired device. A prompt sound will indicate a successful connection.
3. These devices must be within range (10m) and powered on. Please ensure your mobile device has Bluetooth enabled.

# Find My Earbuds

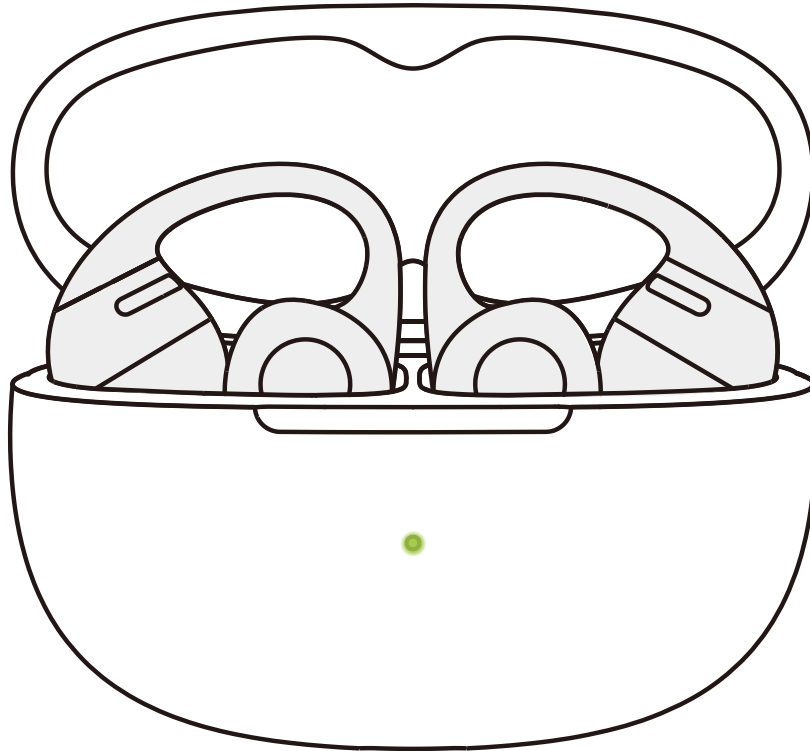

1. Before using, ensure that your earbuds are successfully connected to your phone, then open the Shokz App and select "Find My Earbuds".
2. On the pop-up page, select the earbud you want to locate.
3. Select "Ping Left Ear" / "Ping Right Ear" to make the earbud emit a continuous ringing sound.

\*Note: Do not use this function while wearing the earbuds.

# Resetting the Earbuds

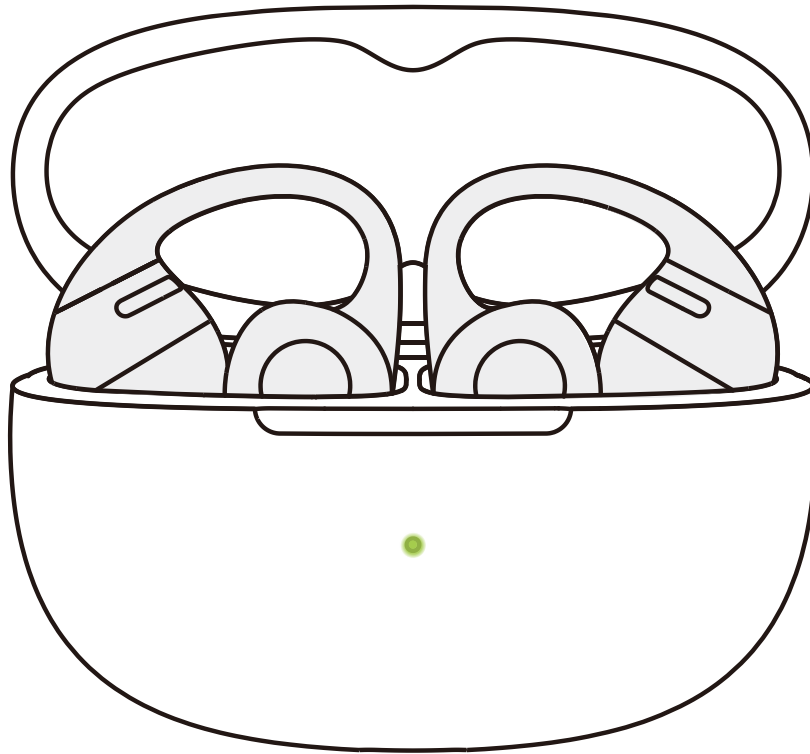

1. Resetting the earbuds will erase the paired device list and restore all settings to their defaults.
2. Place both earbuds into the charging case.
3. With the case lid open, press and hold the charging case function button for 15 seconds. When the orange light inside the case flashes for 5 seconds and then turns off, the reset is complete.
4. Once the indicator light flashes orange and green, the earbuds are ready to pair and use.

# **CLEANING & MAINTENANCE**

---

# Cleaning

1. Cleaning the metal contacts on the charging case and earbuds: Using a pointed-tip cotton swab dipped in a small amount of medical alcohol or clean water, gently press and clean the metal contacts in the recess of the charging case. Then wipe away any excess liquid with a clean, dry, lint-free cloth until completely dry. Clean the metal contacts at the bottom of the earbuds in the same way.

2. After exercising or exposure to liquids, wipe away any sweat, dirt, or debris. Ensure the earbuds and charging contacts are completely dry and free of debris or dirt before placing them in the charging case.

**\*Note:**

When cleaning your earbuds, avoid bending or twisting them excessively, as this may cause warping and affect comfort and fit.

# IP Rating

Under controlled laboratory conditions, the earbud part of this product has been tested for splash resistance, meeting the IP57 level under the IEC 60529 standard.



**\*Note:**

1. The IP57 dust and water resistance is only applicable to the earbud body, not the charging case.
2. The splash-resistant feature is not permanent and may degrade over time due to wear and tear from regular use.
3. Do not immerse the product in water, expose it to prolonged moisture, or wear it during water activities such as swimming, water skiing, or surfing.
4. If the product or its accessories come into contact with water, please wipe them off as soon as possible and place them in a well-ventilated, cool area to dry. Do not use or charge the product before it is completely dry.

# Storage and Maintenance

- This product should be stored in a cool and dry place. Please note that the product's performance is subject to a temperature range of 0°C to 40°C.
- Keep the product away from heat sources, combustible gases, and other cleaning/corrosive liquids. Avoid prolonged sun exposure and use/placement in any high-temperature location.
- Stop using this product immediately if any parts are damaged or produce smoke, heat, or a burning smell.
- The earbud part of this product has an IP57 dust and water resistant function, which allows for non-water sports and exercise but is not entirely dustproof and waterproof. The charging case of this product has an IP54 dust and water resistant function. Do not immerse the product in water. IP57 and IP54 are not permanent protection ratings and may be degraded through normal wear and tear.
- Clean the product with a soft dry cloth.
- After prolonged storage, recharge before use.

# AFTER-SALES SERVICE

# Serial Number Location

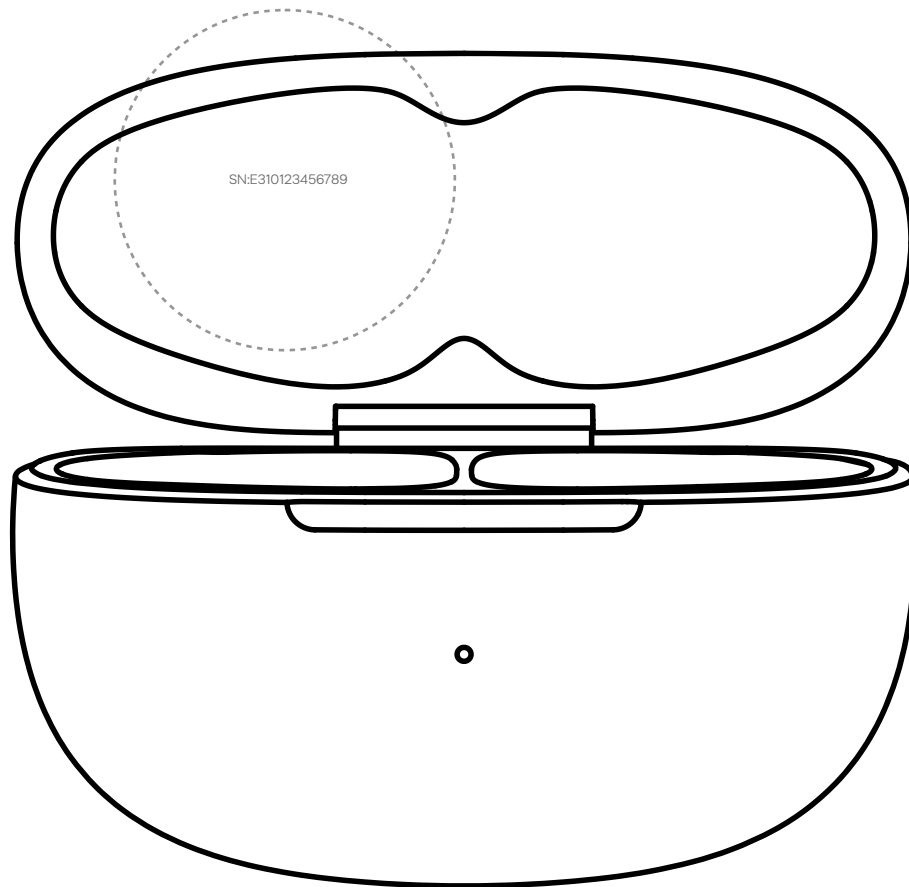

1. The product serial number is indicated on the barcode of the packaging box and on the warranty card.
2. It is also printed on the bottom of the charging case.

# Warranty

Your earphones are covered by a warranty. Visit our website at <https://shokz.com/pages/warranty-return> for details of the limited warranty.



**SHÖKZ**