

# AIRMSSEN

## COFFEE MAKER

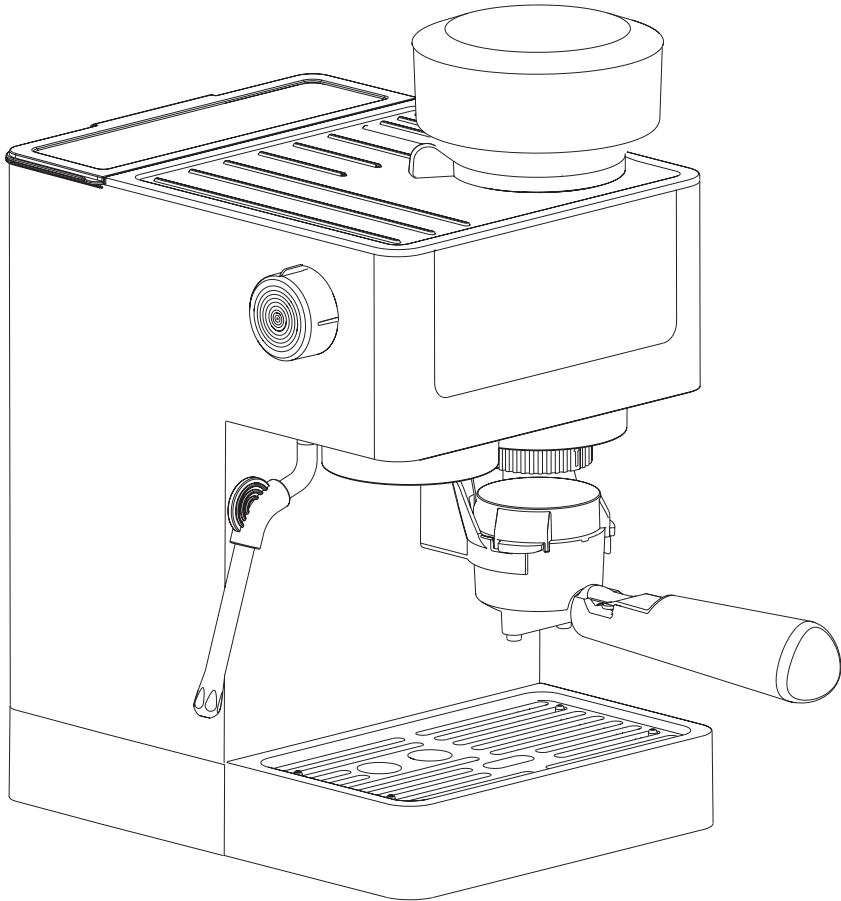

## USER MANUAL

---

If you are having problems using this coffee maker  
Please email : [service@airmsen.com](mailto:service@airmsen.com) or call 1-844-725-2333  
for assistance : [www.airmsen.com](http://www.airmsen.com)

To best serve you, our AIRMSSEN Representatives are available to answer your calls Monday to  
Friday, 10:30 AM - 6:30 PM EST.

THANK YOU FOR MAKING AIRMSSEN APPLIANCES A PART OF YOUR HOME.

# CONSTANT INNOVATION FOR BETTER PRODUCTS

With “technology, innovation, health” as our core value, we strive to provide you with the preferred brand of household products in your healthy and quality life.

AIRMOSEN focuses on researching, developing and manufacturing various kinds of household supplies with advanced technologies and the idea of sustainable development. Aiming to promote the evolution of our lifestyle, we will bring our customers around the world a healthier, happier, more intelligent and ecofriendly home life with our high quality products.

## SAFETY

Your safety and the safety of others is very important.

We have provided many important safety messages in this manual and on your appliance. Always read and obey all safety messages.



**This is the safety alert symbol.**

**This symbol alerts you to potential hazards that can cause serious injury to you and others.**

All safety messages will follow the safety alert symbol.

All safety messages will tell you what the potential hazard is, tell you how to reduce the chance of injury, and tell you what can happen if the instructions are not followed.

# CONTENTS

IMPORTANT SAFETY MEASURES	04
-----	-----
COMPONENT INTRODUCTION	06
-----	-----
CONTROL PANEL	07
-----	-----
PREPARATION BEFORE USE	08
-----	-----
OPERATION TIPS FOR BREWING COFFEE POWDER	09
-----	-----
OPERATION TIPS FOR BREWING COFFEE BEANS	11
-----	-----
COFFEE MAKING	12
ESPRESSO	12
SPRESSO COOL	13
AMERICANO	13
-----	-----
GRINDING	13
-----	-----
STEAM	14
FROTHING MILK	14
-----	-----
CLEANING AND MAINTENANCE	14
CLEANING THE PORTAFILTER AND BREW HEAD	14
CLEANING THE STAINLESS STEEL STEAM WAND	15
GRINDER CLEANING	15
WATER TANK CLEANING	16
SELF-CLEANING	16
DRIP TRAY CLEANING	17
DESCALING	17
-----	-----
TROUBLESHOOTING	18
-----	-----
WARRANTY	21
-----	-----
CUSTOMER SUPPORT	22

# IMPORTANT SAFETY MEASURES

Congratulations on your purchase of the new Airmsen coffee machine. This user manual contains important information regarding the installation, use, and maintenance of this machine. Please spend some time reading this manual to make the best use of all functions of this coffee machine.

## SAFETY INSTRUCTIONS

To reduce the risk of fire, electric shock, and/or personal injury, please always stick to the following basic safety precautions when using this machine::

1. Read all instructions
2. Ensure that your outlet voltage matches the voltage indicated on the label of the coffee machine.
3. To prevent fire, do not immerse the cord, plug, or machine in water or other liquids.
4. Close supervision is necessary when the machine is used by or near children.
5. Unplug the machine when it is not in use and before cleaning, and allow it to cool before attaching or removing parts.
6. Do not operate the machine if the power cord or plug is damaged, or if it malfunctions or is damaged in any way. Return the machine to an authorized service facility for examination, repair, or adjustment.
7. Using accessories not recommended by the machine manufacturer may result in fire, electric shock, or personal injury.
8. To disconnect the machine, turn all controls to the off position, then remove the plug from the wall outlet.
9. Do not touch hot surfaces.
10. Do not use the machine outdoors or for commercial purposes.
11. Do not let the power cord hang over the edge of a table or counter.
12. Use the machine only on a hard, flat, horizontal surface to avoid interrupting the airflow beneath the machine.
13. Before turning on the machine, ensure the water tank lid is tightly closed and filled to the minimum water level or above.
14. Do not remove the portafilter while brewing coffee. Ensure all three indicator lights are on before removing the portafilter to brew more coffee. Be cautious when removing the portafilter as the metal parts can be very hot. Make sure to hold the portafilter and use the filter clip to handle the coffee grounds.
15. Do not remove the water tank before turning off the machine.
16. This machine is not fit for operation via an external timer or separate remote control system.
17. Children must not play with this machine. Unless children are 18 years or older and under supervision, they must not perform cleaning and user maintenance.
18. Keep the machine and its power cord out of reach of children under 18 years old.
19. Before removing any spare or accessory parts, please first ensure that the three indicator lights are on, then press the power button to the off position "0", and finally unplug the machine.

20. Do not remove the portafilter during the brewing process.
21. Please be very careful when removing the portafilter, as the metal parts may still be very hot, and additionally, hot water may be floating on top of the filter. Hold the portafilter only and use the filter clamp to handle the brewed coffee grounds.
22. If the coffee is not dripping, it indicates that the filter is clogged. Turn off the machine and let it cool down. The clog may be caused by coffee that is ground too finely. Refer to the "Problems and Causes" section.
23. Do not place it on or near a hot gas or electric stove, or in a heated oven.
24. This machine is designed for family use or other similar applications, such as:
  - Staff kitchen areas in shops, offices, and other working environments;
  - Farmhouses; clients in hotels, motels, and other residential environments;
  - Bed and breakfast environments.
25. Save these instructions

**NOTE:**

- When using the Espresso/Americano function, do not remove the water tank or portafilter to prevent burns or machine damage. Ensure the machine is in standby mode, with all buttons lit and in a stable condition, before removing the portafilter. To add water, please first press the off button on the side of the machine.
- When using Steam, do not touch the pipes and steam with your hands to avoid burns.

# COMPONENT INTRODUCTION

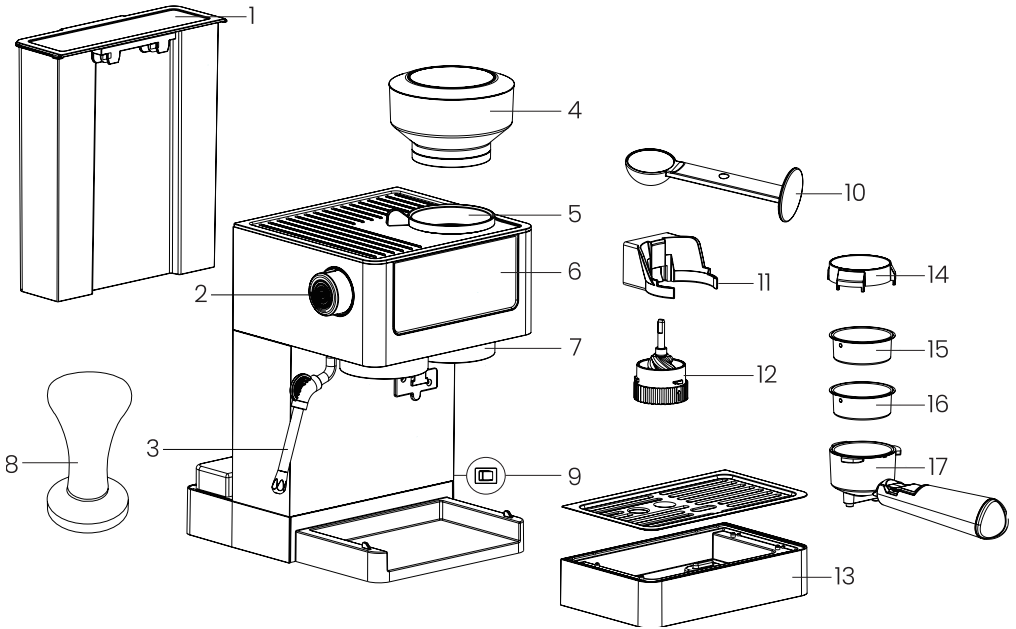

1. 60.87 oz (1.8L) Removable Water Tank
2. Steam Knob
3. Stainless Steel Steam Pipe
4. Removable Bean Hopper
5. Grind Size Adjustment Knob
6. Control Panel
7. Coffee Grounds Outlet
8. Powder Pressing Hammer
9. Machine Switch
10. Coffee Measuring Scoop and Tamper
11. Removable Grinding Bracket
12. Removable Grinding Conical Burr
13. Removable Drip Tray
14. Dosing Collar
15. Double Shot Filter Basket
16. Single Shot Filter Basket
17. Portafilter Holder



# CONTROL PANEL



	Espresso	Espresso Cool	Americano	Grinding
Single	35-50ml (1.18-1.69oz)	120-150ml (4.06-5.07oz)	150-180ml (5.07-6.09oz)	10-12g (0.33-0.34oz)
Pair	80-100ml (2.71-3.38oz)			22-24g (0.7-0.8oz)

1. When the power button is turned on, the machine will beep and enter the standby mode. All buttons of available functions on the display will light up.

**Note: In the standby mode, the machine will not automatically start preheating.**

2. When you select the coffee "  ", only this "  " will remain on and will flash for the remainder of the preheating time.

**Note: Do not press the button again, otherwise your selection will be canceled.**

3. When preheating is completed and coffee brewing begins, the selected coffee function will remain lit, and the machine will beep three times after the brewing cycle is completed; all function icons will light up, and the machine will return to the standby mode. If the espresso machine is no longer in use, please turn it off.
4. In case of inactivity for five minutes, the machine will enter the sleep mode. All lights will be turned off. When you tap any function key on the screen, the screen will light up and enter the standby mode.
5. **If you need to customize the amount of coffee press and hold the icon for 3 seconds. When the icon and text flash at the same time, it means that you have entered the custom mode. Touch the icon again to complete the setting. After the setting is completed, the device will beep three times, and the next time you make it, it will be produced according to the set amount. To cancel all custom settings, press and hold the "steam icon" for 3 seconds, and the device will beep five times to indicate that the custom settings have been canceled.**

# PREPARATION BEFORE USE

## NOTE:

- After placing the machine on the workbench, leave at least 3cm of space from the machine surface to the side wall or back wall, and at least 15cm of space above the coffee machine, as the machine will turn to be very hot.
- During the first time you use this machine, the machine will be noisy as the water circuit is empty.  
As the circuit fills gradually, the noise becomes smaller and smaller.
- Wash all accessories with warm water and detergent.
- If the machine has not been in use for more than 3-4 days, rinse the internal circuit before making the first drink.

**When preparing to use the coffee machine, please ensure that the steam knob on the left side of the machine is closed. Otherwise, the “Steam” indicator on the control panel will keep flashing, and when you select the coffee function, water will come out of the steam pipe, preventing the coffee from being brewed. Rotate the steam knob to the “O” (off) position to stop the “Steam” from flashing, and the coffee function will work normally.**

1. Plug into the power socket, and press the ON/OFF switch;
2. Place a cup with a capacity of at least 100 ml under the hot water nozzle;
3. Press the **“ESPRESSO”** button. The coffee brewing starts and stops automatically. Empty the container. Before using the coffee machine, the internal circuit of the machine must be rinsed.

## **Use the coffee machine according to the following steps:**

4. Place the coffee filter into the filter holder;
5. Install the filter holder along with the filter onto the machine; Please correctly install the portafilter under the coffee outlet (refer to page 9 for brewing coffee powder). Align it with the unlock symbol, slide it into the groove, then slowly rotate it to the right to the lock symbol;
6. Place the cup under the filter holder and steam pipe;
7. Press the ESPRESSO button. The coffee brewing starts;
8. When the coffee brewing is completed, press the steam “” button to transport steam for a few seconds before the steam circuit is rinsed. For best performance of the machine, please repeat the process 3 to 4 times, with an purpose to clear water from the circuit when using steam. Then the machine is ready. Please note: In case of inactivity of the machine for a long time, rinsing its internal circuit is also highly recommended. For the first time you use the machine, you need to make 4-5 cups of coffee before the machine can work satisfactorily.

# OPERATION TIPS FOR BREWING COFFEE POWDER

## 1. Fill the water tank with water

Fill the water tank with water. You can use a jug to fill the tank or remove it from the machine and fill it under the tap. If you have removed it from the machine to fill it with water, make sure to place it back tightly. Pour water into the tank as required, ensuring its amount fits within the "MIN" and "MAX" marks on the tank. Never use warm or hot water to fill the tank.

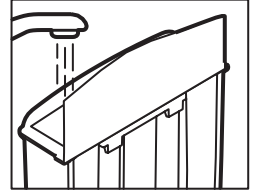

## 2. Select the appropriate powder filter and securely install it on the filter holder.

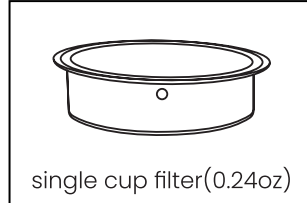
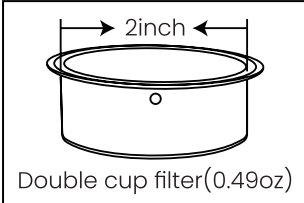

## 3. Insert the powder filter into the filter holder.

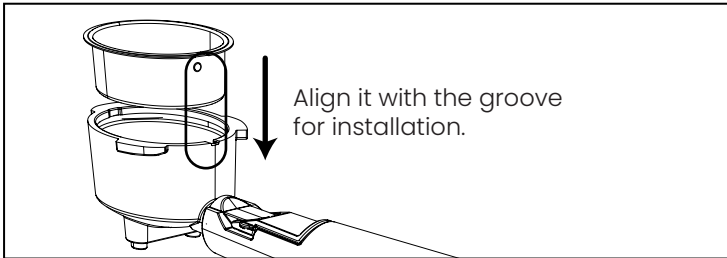

**Note:** Before brewing coffee, please press the coffee button to brew a cup of water without adding coffee powder. This step is to clean the machine and increase the temperature before the next extraction.

## 4. Use a measuring spoon to pour the freshly ground coffee into the filter paper. Use a powder tamper to flatten the coffee powder and remove the excess powder on the edge.

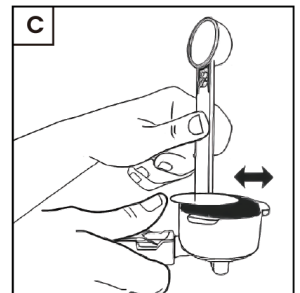
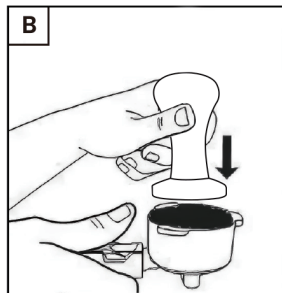
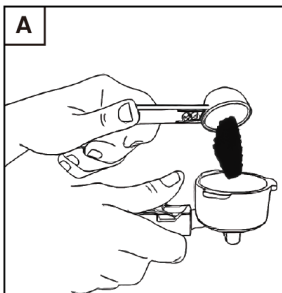

5. Install the portafilter below the coffee outlet. Align it with the unlock symbol, slide it into the groove, and then slowly rotate it to the right until it reaches the lock symbol.

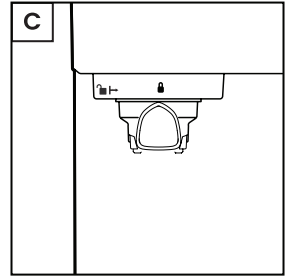
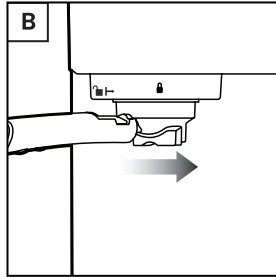
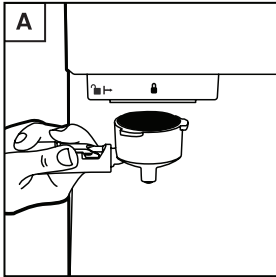

**NOTE:**

- A. Place the portafilter under the brew head and install it after the clamp is moved backward.
- B. Place the portafilter to align with the unlock button "🔓" on the machine and fit it into the groove.
- C. Then, slowly turn it to the right until the clamp aligns with the lock symbol "🔒" on the machine.

**NOTE:**

When using the Espresso/Americano function, do not remove the water tank or portafilter to prevent burns or machine damage. Ensure the machine is in standby mode, with all buttons lit and in a stable condition, before removing the portafilter. If you need to add water, first press the "off" button on the side of the machine.

# OPERATION TIPS FOR BREWING COFFEE BEANS

1. Place the coffee beans into the bean hopper. It is better to grind only the amount of coffee beans needed for immediate use to ensure the coffee will always be freshly brewed.
2. Align the unlock "☐" button on the bean hopper with the triangle "▲" button on the machine, then slowly rotate it to the left until it reaches the lock "☒" button.
3. The default grind setting is 5-7 (medium grind). If the coffee is ground to be too fine or too coarse, adjust the grinding level to satisfy your personal taste and fit the type of coffee used.

**Note:** There are numbered settings on the grind fineness selector. The smaller the number, the finer the coffee grind. The larger the number, the coarser the coffee ground. It is recommended you start with setting 5 and adjust it as needed.

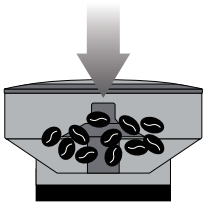

1

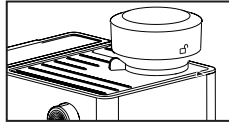

2



3

## Please note:

- Different varieties of coffee beans will produce different grinding effects, so the initial adjustment of the dose requires special care.
  - For most coffees, a grind level is recommended between 3 and 6.
  - Selecting 1 or 2 for very fine grinding. It is only used for very special coffees (light roast) or when you notice poor coffee brewing quality due to burr wear (too coarse grinding).
4. Place the dosing collar on the filter holder.

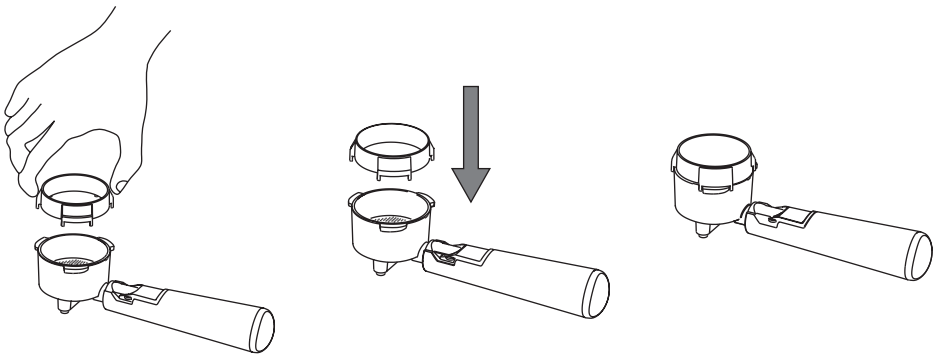

5. Place the filter holder on the grinding bracket.

6. Touch the grinding button “  ” to select 1 cup or 2 cups, the machine starts working and stops automatically after grinding is completed.

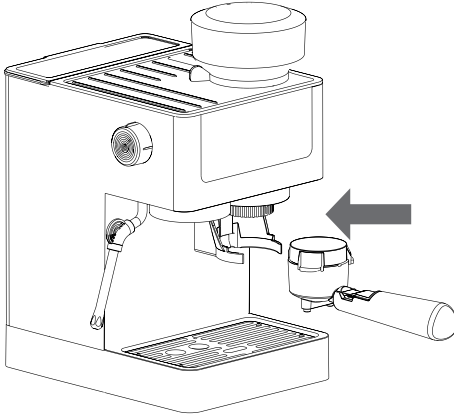

5

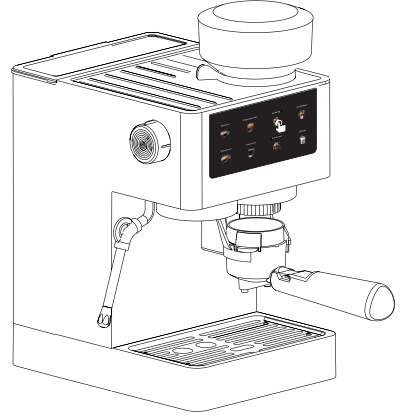



6

## COFFEE MAKING

### ESPRESSO

Espresso is a unique brewing method that quickly extracts finely ground coffee powder with high-pressure hot water, resulting in a concentration much higher than regular drip coffee. Therefore, espresso is usually served in small portions in special small cups.

1. Ensure the machine is plugged in.
2. Press the power button on the side of the machine.
3. Pour water into the tank as required, ensuring its amount fits within the “MIN” and “MAX” marks on the tank. Do not use hot water to fill the water tank.
4. Place the needed coffee beans into the bean hopper, grind them into coffee powder, and send it to the brew head as instructed (refer to “coffee powder brewing operation” on page 9-10 and “coffee bean brewing” on page 11-12).
5. Place a heat-resistant cup or small coffee cup on the metal coaster above the drip tray.
6. Select to brew “  ” or “  ”, press the corresponding button to choose ESPRESSO. The flashing button indicates that the machine is preheating, and the button will remain lit during brewing. The machine will emit three beeps to indicate the completed brewing process, and then you can enjoy your espresso.
7. At the end of the brewing, the machine will enter the standby mode and preheat in the background. If no button is pressed within 5 minutes, it will enter the sleep mode.
8. To discard used coffee grounds, please remove the portable filter and let it cool. Flip the portafilter basket clamp upwards to partially cover the edge of the basket and portafilter, secure the portafilter basket in place, and press the clamp with your thumb to keep the basket in place while emptying the coffee grounds.

## SPRESSO COOL

If you want to drink iced coffee, you can make it according to the following steps:



1. Fill with room temperature or icy water.
2. Plug in the power and turn on the power switch. All function buttons will light up. The machine will be in the standby mode. (Note: The coffee machine will not preheat automatically.)
3. Place the needed coffee beans into the bean hopper, grind them into coffee powder, and send it to the brew head as instructed (refer to “coffee powder brewing operation” on page 9-10 and “coffee bean brewing” on page 11-12).
4. Place the cup under the portafilter and press the “” button. The machine will automatically brew iced coffee. The machine will emit three beeps to indicate the completed brewing process, and your iced coffee is ready to enjoy.
5. After the brewing ends, the machine will enter the standby mode. If no button is pressed within 5 minutes, it will enter the sleep mode.

**Note:** The Espresso Cool function is suitable for first-time use or when the machine has not been used for a long time. After using the Espresso function, you need to release the hot water in the boiler to use the Espresso Cool function immediately. When the icon flashes alternately, it means that the boiler is cooling down. After the cooling is completed, the device beeps three times and you can brew iced coffee again.

## AMERICANO

1. Plug in the power, turn on the power switch, all function keys light up, and the machine is in the standby mode. (The coffee machine will not preheat automatically.)
2. Put the needed coffee beans into the bean hopper, grind them into coffee powder, and send it to the brew head according to the instructions (refer to “coffee powder brewing operation” on page 9-10 and “coffee bean brewing” on page 11-12).
3. Place the cup under the portafilter, press the button “”, and the machine will automatically brew the coffee. The machine will emit three beeps to indicate that brewing is completed, and then you can enjoy your coffee.
4. After the brewing ends, the machine will enter the standby mode. If no button is pressed within 5 minutes, it will enter the sleep mode.

## GRINDING



1. Plug in the power and turn on the power switch. All function buttons will light up. The machine will be in the standby mode.
2. Touch the 1 cup “” or 2 cups “” icon and the appliance starts working. When grinding is complete, three “beep” prompt sounds will be heard.

**Note:** This function can be customized to grind coffee powder “” according to your needs.

3. At the end of the grinding, the machine will enter the standby mode. If no button is pressed within 5 minutes, the machine will enter the sleep mode.

# STEAM

## FROTHING MILK

1. Pour 120-180 ml of fresh cold milk into the milk frother.
2. In the standby mode, press the "  " button until it flashes, indicating that the machine is heating to steam temperature.
3. When the "  " button stops flashing and lights up, the machine is ready to produce steam.
4. Wait for the steam to work for 3-5 seconds to clear any condensation, then turn the "steam knob" to the standby position, and place the milk jug under the frothing nozzle.
5. The steam knob can be used to adjust the denseness of steam.
6. Insert the frothing nozzle at a place 1-2 cm below the surface, near the 3 o'clock position on the right side of the milk jug.
7. Keep the frothing nozzle below the surface until the milk rotates clockwise, creating a vortex (whirlpool effect).

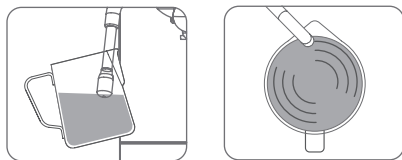

8. While the milk is spinning, slowly lower the steam nozzle close to the liquid surface and begin injecting steam. To maintain a stable vortex, slightly adjust the nozzle angle to help break the surface tension and produce thorough foaming.
9. Keep the steam nozzle slightly below the milk surface, maintaining a stable vortex to evenly incorporate steam and form fine foam until the desired expansion and texture are achieved.
10. The steam nozzle is fully immersed in the milk but still maintains a stable vortex rotation. When the outer wall of the milk pitcher becomes too hot to touch (approximately 60-65°C), please immediately stop heating.
11. Press the "  " button again to stop the whole process.
12. Turn the "Steam Knob" back to the standby position to exit the steam mode.

## CLEANING AND MAINTENANCE

### CLEANING THE PORTAFILTER AND BREW HEAD

1. Before cleaning, turn off the machine and unplug it. Some metal parts may still be hot. Do not touch them with your hands before they completely cool down.
2. Please remove the portafilter and discard the used coffee grounds. To keep the basket in place while dumping the coffee grounds, please flip the portafilter basket holder and hold it with your thumb while emptying the basket.
3. Rinse thoroughly the filter and portafilter with warm soapy water. Single and double cups filters can be washed on the top rack of the dishwasher, but the portafilter cannot be washed there.

4. Wipe the bottom of the brew head with a damp cloth or paper towel to remove any remaining coffee grounds.

## CLEANING THE STAINLESS STEEL STEAM WAND

1. After use, use steam to remove milk residue from the steam wand.
2. Wipe the steam wand after each use.
3. Unscrew the frothing nozzle counterclockwise to remove it.
4. Soak the frothing nozzle in water for several hours before reinstalling it or wait until the steam wand cools down. To ensure the steam wand works effectively for a long time, use a special cleaning tool to remove any blockages in the holes.

**Note:** Clean the steam wand according to the above instructions after each use.

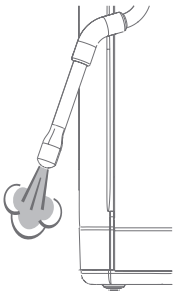

1

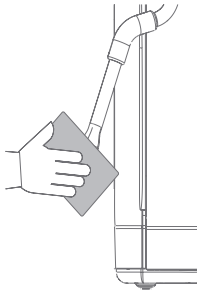

2

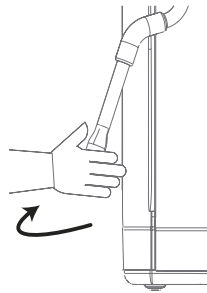

3



4

## GRINDER CLEANING

1. Hold the conical burr and rotate it to the right in the direction of the arrow, until you hear a "click" sound. Unlock.
2. Pull down the conical burr.
3. Clean the coffee grounds outlet and conical burr with a brush.

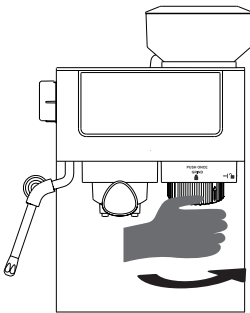

1

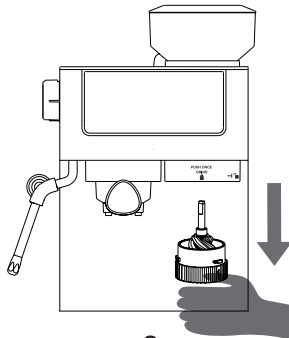

2

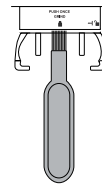

3

4. Hold the conical burr and insert it into the correct position.

5. Rotate it to the left in the direction of the arrow, until you hear a “click” sound that indicates it is locked

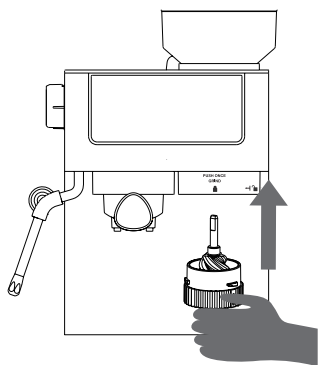

4

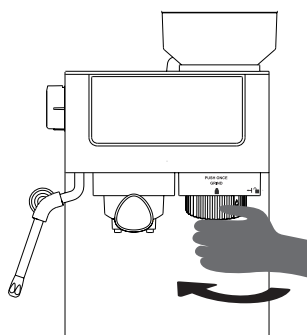

5

## WATER TANK CLEANING

Empty the water tank after use. Pour out the remaining water in the tank, clean the tank with soapy water if necessary, and dry it. The water tank is not applicable for dishwashers.

## SELF-CLEANING

1. After use for several months, the machine will remind you to clean (the system will automatically enter the cleaning mode after brewing 500 cups of coffee). The ESPRESSO and ESPRESSOx2 buttons will flash. Other function buttons will light up. Place a large cup under the brew head.
2. Press the ESPRESSO and ESPRESSOx2 buttons simultaneously to automatically enter the cleaning mode (pump water for 50 seconds, pause for 10 seconds: pump water again for 50 seconds, pause for 10 seconds; pump water again for 50 seconds, then the cleaning is completed). To exit the cleaning mode, press and hold the ESPRESSO and ESPRESSOx2 buttons for three seconds to exit the cleaning mode.

**Note:** In case of sudden power-off when the machine is in the cleaning process, please repeat the above steps after restarting it.

### WARNINGS!

- Do not use solvents, abrasive cleaners, or alcohol to clean the coffee machine.
- Do not use metal objects to remove scale or coffee deposits.
- If the machine is left unused for more than a week, it is recommended you perform a rinse cycle before use. Danger!
- Never immerse the coffee machine in water during cleaning,
- Before starting any cleaning operation on the exterior of the machine, turn it off, unplug it from the power socket, and wait for it to cool down.

## **DRIP TRAY CLEANING**

1. The drip tray should be regularly removed, emptied, and cleaned,
2. The storage tray can be removed and cleaned with a soft and damp cloth. Do not use abrasive cleaners, pads, or cloths that can scratch the surface.

## **DESCALING**

1. Descaling agents may damage delicate surfaces. If the descaling agents are accidentally spilled, please wipe them up immediately.
2. Remove and empty the drip tray, then place it back into the machine.
3. Empty the water tank. (If there is any descaling agent left in the tank, place a soft ball in a glass of water until it can be reinserted at the end of the descaling process.)
4. Pour the descaling agent into the water tank until the liquid level reaches MAX.

# TROUBLESHOOTING

## **Q1: THE MACHINE IS TURNED ON BUT HAS STOPPED OPERATING.**

Due to overheating of the pump or grinder, the safety thermal cut-out may have been activated.

### **REMEDY**

Press the power button to turn off the machine and unplug it from the power socket. Cool the machine down for 30–60 minutes. If the problem persists, please contact our customer support.

## **Q2: THE MACHINE'S COFFEE HEAD ISN'T DISPENSING COFFEE.**

1. The machine has not reached the working temperature.
2. The water tank is empty.
3. The water tank is not fully inserted and locked into place.
4. The machine needs descaling.
5. The coffee is ground too finely, there is too much coffee in the filter basket, it is over-tamped, or the filter basket is clogged.

### **REMEDY**

1. Allow the machine to reach the working temperature. All button lights on the control panel will be lit.
2. Fill the water tank with water.
3. Push the water tank fully down to lock it into place.
4. Refer to “Descaling” on page 17.
5. See below, espresso only drips from the coffee spout or does not drip at all. (Please refer to Item Q3.)

## **Q3: COFFEE ONLY DRIPS FROM THE COFFEE SPOUT OR DOES NOT DRIP AT ALL.**

1. The coffee is ground too finely.
2. There is too much coffee in the filter basket.
3. The coffee is tamped too tightly.
4. The filter basket may be clogged.

### **REMEDY**

1. Use slightly coarser coffee grounds. “Refer to Item No.3 on page 11 for coffee bean brewing instructions.”
2. Use low-dose coffee.
3. The pressure should be set between 30–40 pounds or 15–20 kilograms.
4. Use the pin at the end of the provided cleaning tool to unclog the holes. If the hole is still clogged, dissolve the cleaning tablet in the hot water, then soak the filter basket and portafilter in the solution for about 20 minutes.

## **Q4: THE COFFEE IS NOT HOT ENOUGH.**

1. The cup is not preheated.
2. The coffee portafilter is not preheated.

### **REMEDY**

1. Rinse the cup under the hot water outlet and then place it on the cup warming tray.

2. Rinse the coffee portafilter at the hot water outlet and dry it thoroughly.

**Q5: ESPRESSO FLOWS FROM THE EDGE OF THE COFFEE CUP.**

1. The portafilter is not properly inserted into the group head.
2. There are coffee grounds around the edge of the filter basket.
3. Too much coffee powder in the filter basket.

**REMEDY**

1. Ensure the portafilter is fully inserted and rotated until you feel resistance.
2. Clean excess coffee from the edge of the filter basket to ensure a proper seal in the brew head.
3. Low-dose coffee.

**Q6: ESPRESSO IS TOO WEAK.**

1. The coffee is ground too coarsely.
2. Not enough coffee in the filter basket.

**REMEDY**

1. Use slightly finer coffee grounds. "Refer to Item No.3 on page 10 for coffee bean brewing instructions."
2. Increase the dose of coffee powder.

**Q7: THE COFFEE HAS NO CREMA.**

1. The coffee is tamped too lightly.
2. The coffee is ground too coarsely.
3. The coffee beans or pre-ground coffee are not fresh.
4. The filter basket may be clogged.

**REMEDY**

1. The tamping pressure is set between 30-40 pounds or 15-20 kilograms.
2. Use slightly finer coffee grounds. "Refer to Item No.3 on page 10 for coffee bean brewing instructions."
3. In case of grinding fresh whole coffee beans, please use freshly roasted coffee beans labeled with a "roast date" and consume them within 5-20 days following that date. For pre-ground coffee, please use it within one week after it is ground.
4. Use the pin at the end of the provided cleaning tool to unclog the hole. If the hole remains clogged, dissolve a cleaning tablet in the hot water and soak the filter basket and spout in the solution for about 20 minutes. Rinse thoroughly.

**Q8: THE MACHINE IS NOT HEATING. WHEN THE MACHINE IS TURNED ON, THE STEAM BUTTON LIGHT IS FLASHING.**

The steam knob is not in the standby position.

**REMEDY**

Turn the steam knob to the standby position. The machine will start heating.

**Q9: NO STEAM**

1. The machine has not reached the working temperature.
2. The water tank is empty.
3. The water tank is not fully inserted and locked into place.
4. The machine needs descaling.
5. The steam wand is clogged.
6. The steam knob is not in the steam position.

**REMEDY**

1. Allow the machine to reach the working temperature. The steam button is flashing, indicating that the machine is heating up to produce steam. During this time, the condensation may be discharged from the steam wand, which is normal. When the steam button stops flashing, the steam wand is ready to use.
2. Add water to the water tank.
3. Push the water tank down to lock it
4. Refer to “Descaling” on page 17.
5. Refer to “Stainless Steel Steam Pipe Cleaning” on page 15.
6. Ensure the steam knob is fully rotated to the steam position.

**Q10: THE GRINDER IS NOT PRODUCING GROUND COFFEE.**

1. There are no coffee beans in the bean hopper.
2. Grinding chamber is clogged.
3. There is water/moisture in the grinding chamber.

**REMEDY**

1. Pour fresh coffee beans into the bean hopper
2. Clean and clear the grinder. Please refer to “Grinder Cleaning” on Page 15.
3. Clean and clear the grinder. Please refer to “Grinder Cleaning” on Page 15. Ensure the burrs are completely dry before reassembly. You can use a hair dryer to blow air into the grinding chamber.

**Q11: THE GRINDER IS MAKING A LOT OF NOISE.**

There is a blockage or foreign object inside the grinder.

**REMEDY**

Remove the hopper and check for debris or blockages. If necessary, clean and clear the grinder chamber and chute. Refer to “Grinder Cleaning” on Page 15.

# WARRANTY

Product Name	Model Number	Default Warranty Period	Date of Purchase	Order Number	For your own reference, we strongly recommend that you record your order number and date of purchase.
COFFEE MAKER	BCM2316	2 years			

## TERMS & POLICY

AIRMOSEN warrants all products to be of the highest quality in material, craftsmanship, and service, effective from the date of purchase to the end of the warranty period.

AIRMOSEN will replace any product found to be defective due to manufacturer flaws based on eligibility. Refunds are available within the first 30 days of purchase. Refunds are only available to the original purchaser of the product. This warranty extends only to personal use and does not extend to any product that has been used for commercial, rental, or any other use in which the product is not intended for. There are no warranties other than the warranties expressly set forth with each product.

This warranty is non-transferrable. AIRMOSEN is not responsible in any way for any damages, losses, or inconveniences caused by equipment failure by user negligence, abuse, or use noncompliant with the user manual or any additional safety or usage warnings included in the product packaging and manual.

### THIS WARRANTY DOES NOT APPLY TO THE FOLLOWING:

- Damage due to abuse, accident, alteration, misuse, tampering, or vandalism.
- Improper or inadequate maintenance.
- Damage in return transit.
- Unsupervised use by children under 18 years of age.

AIRMOSEN assume no liability for damage caused by the use of the product other than for its intended use or as instructed in the user manual. Some states do not allow this exclusion or limitation of incidental or consequential losses, so the foregoing disclaimer may not apply to you. This warranty gives you specific legal rights and you may also have other rights, which may vary from state to state.

**ALL EXPRESSED AND IMPLIED WARRANTIES, INCLUDING THE WARRANTY OF MERCHANTABILITY, ARE LIMITED TO THE PERIOD OF THE LIMITED WARRANTY.**

## DEFECTIVE PRODUCTS & RETURNS

Should your product prove defective within the specified warranty period, please contact Customer Support via [service@airmsen.com](mailto:service@airmsen.com) with your order number. DO not dispose of your product before contacting us. Once our Customer Support Team has approved your request, please return the unit with a copy of your invoice and order number.

# CUSTOMER SUPPORT

## WE'RE HERE TO HELP!

If you encounter any issues or have any questions regarding your new product, please contact our helpful Customer Support Team. Your satisfaction is our goal!

## CUSTOMER SUPPORT

Email: [service@airmsen.com](mailto:service@airmsen.com)

Telephone: **1-844-725-2333**

**\* To best serve you, our AIRMSEN Representatives are available to answer yourcalls Monday to Friday, 10:30 AM – 6:30 PM EST.**

If you need to purchase product accessories, please visit [www.airmsen.com](http://www.airmsen.com).

\* Please have your order confirmation number ready before contacting Customer Support.



<https://www.facebook.com/Airmsen>



<https://www.youtube.com/@AIRMSEN>

For product operation videos, please subscribe to AIRMSEN's official Youtube account.

---



# AIRMSSEN

QUESTIONS OR COMMENTS?

<b>EMAIL</b>	<b>OR VISIT US ONLINE AT</b>
service@airmsen.com	www.airmsen.com

