



MEMPHIS

MXA

850.5M/480.4M/600.1M
MARINE GRADE AMPLIFIERS



ENGINEERED TO RESIST
WATER & ELEMENTS



MXA850.5M
 MXA480.4M
 MXA600.1M

READY TO TURN IT UP? READ THIS FIRST!

Memphis Audio built a 50 year legacy in the audio industry by engineering the highest quality products to produce the best possible listening experience for our fans and loyal supporters. To fully appreciate our products we recommend taking the time to read and follow the instructions in this manual. As always, we recommend all the installations and services to be performed by an authorized Memphis Audio dealer.



For optimal performance, Memphis recommends using only Memphis Connection accessories. Outfitting your system with properly sized Memphis Connection wire and accessories will dramatically boost your listening experience and increase the durability of your Memphis Audio products.

Memphis Audio's MXA amplifiers, are water resistant to protect them from the elements. These units features easy access top mounted controls protected by a water resistant panel. Do not operate these amplifiers in areas with increased moisture without the panel properly installed and tightened to create a seal.



Combine with our Memphis Bluetooth Accessories and Memphis Xtreme speakers for the perfect rugged solution for Xtreme sound wherever you go!

FEATURES

- Water and element resistant
- Conformal coated circuit board
- Efficient class D design
- Variable subsonic and bass boost
- 3-Zone remote included (MXA850.5M)

SPECIFICATIONS

Specifications	MXA850.5M	MXA480.4M	MXA600.1M
RMS Power/CH @ 4Ω	60x4 +175x1	80x4	250x1
RMS Power/CH @2Ω	100x4+300x1	120x4	400x1
RMS Power/CH @ 1Ω	450x1	-	600x1
RMS Power/Bridge 4 Ohms	200x2+N/A	240x2	-
THD	<1%	<1%	<1%
Signal/Noise Ratio			
Frequency Response ± 0.5dB			100mV-5.5V
Crossover Frequency (HPF)			
Crossover Frequency (LPF)			
Dimensions (in)	13.4x6.10x2.16	10.2x6.1x2.16	10.2x6.1x2.16
Input Sensitivity			
Low Level			
High Level			
Input Impedance			
Low Level			
High Level			
Fuse			

*Features and Specifications are subject to change without notice.

Warranty

Memphis Xtreme Audio Amplifier Limited Warranty

This product has a 2 year warranty from the date of purchase for defects in material or workmanship. This warranty will be extended to 3 years when installed by a Memphis authorized dealer using Memphis Connection products. The warranty is void if the product has been physically damaged by improper usage or abuse. If repairs are attempted outside of a Memphis Audio facility, the warranty is void.

This warranty is limited to the original retail purchaser and does not cover any expenses incurred in the removal or re-installation of the product. This warranty does NOT apply to product exterior and cosmetics. Memphis Audio disclaims any liability for incidental or consequential damages caused by product defects. Memphis Audio liability will not exceed the purchase price of the product and the warranty period specified.

What is NOT covered under warranty

- Damage due to improper installation
- Damage caused by exposure to moisture, excessive heat, chemical cleaners and/or UV radiation
- Damage through negligence, misuse, accident or abuse. (Repeated returns for the same damage may be abuse)
- Product damaged in accident and/or due to criminal activity
- Service performed by anyone other than Memphis Audio
- Subsequent damage to other components
- Any cost or expense related to the removal or re-installation of product
- Products with tampered, missing, altered or defaced serial numbers/labels
- Freight damage
- The cost of shipping product to Memphis Audio
- Return shipping on non-defective items
- Any product not purchased from an authorized Memphis Audio dealer

Some states do not allow the exclusion or limitation of incidental or consequential damages. The above limitations or exclusions may not apply to you. This warranty gives you specific rights, you may have other rights which vary from state to state.

If warranty service is required, a return authorization number is required to return the product to Memphis Audio. Warranty shipments to Memphis Audio are the responsibility of the purchaser. Pack the product carefully in the original carton if possible. Memphis Audio will not be responsible for damages incurred in shipment or due to improper packaging materials used by the purchaser.

If determined to be within warranty your product will be repaired or replaced at the discretion of Memphis Audio.

Service>Returns

Please consult with your local authorized dealer if you experience issues with your unit. You may also contact Memphis Audio customer service at 800-489-2300 or email tech support directly at: techsupport@memphis-caraudio.com. Do not attempt to return your amplifier directly to us without first calling for a Return Authorization number. Units received without an accompanying Return Authorization number will be processed more slowly. Additionally, you must include a copy of your purchase receipt from an authorized dealer for consideration of in-warranty service, otherwise repair charges will apply. Units received without a receipt will be held for up to 30 days allowing us time to contact you and obtain a copy of the receipt. After 30 days all units will be returned to you unrepared.

Installation Information

Memphis Audio recommends the installation of our products to be performed by an Authorized dealer. Attempting an installation project on your own or through an unauthorized source may result in damage to your products and may potentially void your warranty.

Amplifiers should be mounted in areas that receive adequate ventilation. These amplifiers are water and element resistant but should be mounted in areas that do not receive excessive direct contact with water. These amplifiers are not intended to be submerged and care should be used when determining a mounting location.

Warning

For your safety, always inspect the mounting location carefully to ensure you are not drilling into any electrical, hydraulic, fuel or fluid lines. Always check your speaker load with a multi-meter before connecting the amplifier. Connecting any speaker load lower than the rated impedance of the amplifier will result in damage to the amplifier. Damage of this nature is NOT covered under warranty. Please pay close attention to what connections are made to the amplifier.

TIP



If you are uncertain or uncomfortable proceeding with your installation, please contact your local authorized Memphis Audio Dealer

Troubleshooting

When troubleshooting your amp, speaker and speaker wires should be tested first.

No Output:

- Confirm all wiring is firmly connected. Both +12V and REM terminals must have +12 Volts present and GND must be connected to chassis' ground or to the negative battery terminal.
- Confirm the signal source is connected and supplying an output signal. To confirm the amp is working, connect an RCA patch cord to the line inputs of the amplifier (do not connect the other end of the patch cord). Briefly tap the center pin of each disconnected RCA with your finger. This should produce a noise (brief static or hum) in the speakers.

The Amp Is Hot: check the speaker impedance or load. The total minimum impedance of all speakers should not be lower than the rating of the amp.

Only One Channel Works:

- Confirm the speaker terminal strip connections are firmly connected.
- Check "balance" control on your signal source.
- If using RCA Low-Level inputs, reverse the input plugs at the amplifier. If the channel that is silent reverses position, the problem is in the source unit or connecting cable.

Weak Output

- Check input sensitivity control adjustment.

Unwanted Noise

- Whine that increases and decreases with engine speed - confirm the Amp & Source unit are grounded properly.
- Clicking or popping noise at a rate that follows engine speed - this is often induced by the vehicles ignition system. Confirm that the vehicle is equipped with resistor spark plugs and wires. The ignition system may need service.
- Noise can be caused by routing speaker input wires too close to the light wires and other accessory wires in the vehicle. Re-route wires to avoid unwanted interference.
- If above steps do not improve/reduce noise, the system should be checked by a professional audio installer at a Memphis Authorized Dealer.

Red LED is Illuminated

- Speaker or wire is shorted
- Battery voltage too high
- Amplifier has overheated due to improper ventilation
- Battery voltage too low

Power Supply Connections



Install the fuse at the battery last!



Use conventional stranded copper wire for all connections. Tinned Copper MXA marine grade wire is recommended for corrosion resistance in powersports and marine applications. Finish the ends of the wires at the amp and vehicle with proper size terminals. Poorly made connections and/or inadequate wire size will generate excessive heat and may lead to equipment failure.

12 Volt + Connection

make the 12V+ connection directly at the positive battery post using the proper wire size and fuse listed below, The fuse should be installed within 18" of the battery for standard applications and withing 7" of the battery for marine applications*. This fuse is vital to protecting the vehicle from damage in the case of a dead short. The fuse value at the battery should be at least equal to the total fuse value of all the amplifiers being used.

Model	Amp Kit	Fuse Value
MXA850.5M	4GKIT	
MXA480.4M	8GKIT	
MXA600.1M	4GKIT	

Ground Connection:

For marine applications connect the ground to the negative battery terminal. For non-marine applications ground connection directly to the chassis of the vehicle as close to the amp as possible. Make sure this connection is made with the same wire size as used for the 12 volt connection. Ensure that all dirt, grease, paint and coatings are removed prior to attaching the ground wire to chassis.

Remote Turn On

Remote turn on should be connected to the source unit's remote turn on lead. 18 gauge wire should be ran from the remote turn on lead on your source unit to the terminal labeled REM on your amplifier.

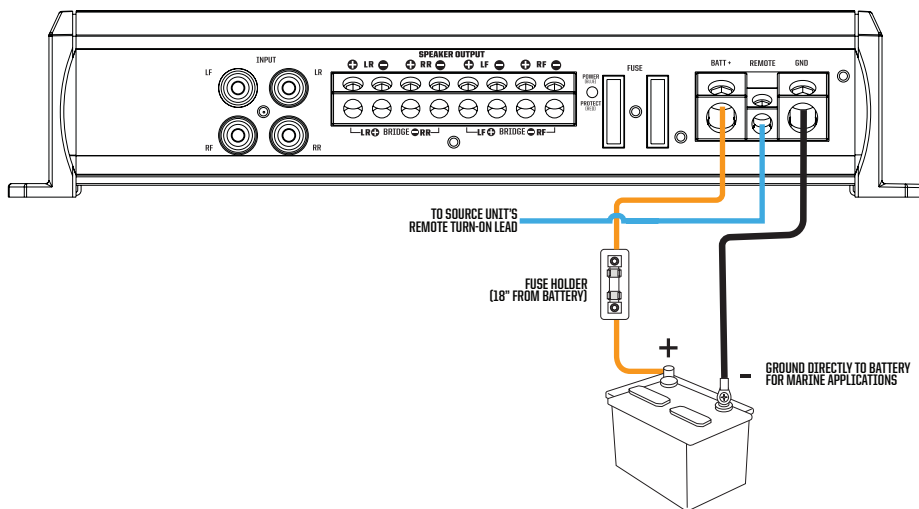

*NOTE: Seven inches is the standard distance under U.S. Coast Guard CFR33 for placement of fuses or breakers as required by law for new boat manufacturing. It is recommended that you adhere to this standard in an installation. Not adhering to this regulation puts the safety of boat passengers at risk in the event of a power wire short circuit.

Control View

MXA850.5M

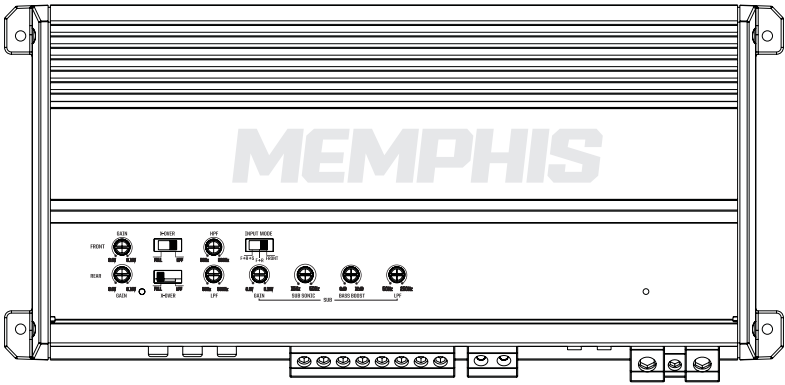

MXA480.4M

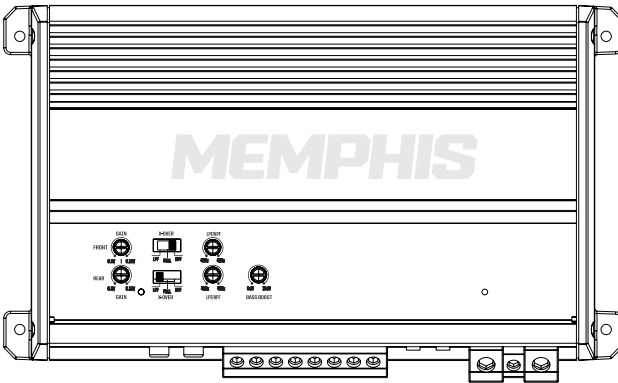

MXA600.1M

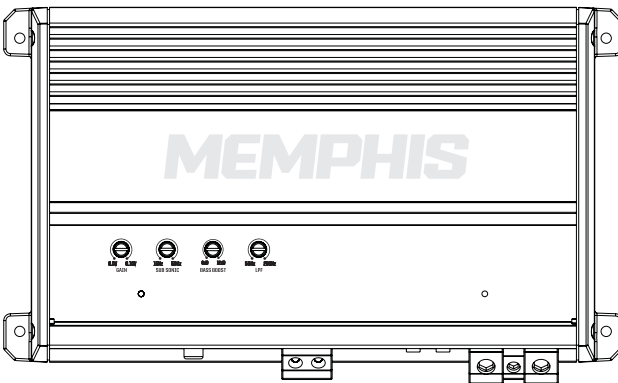

Gain

The gain control is NOT a volume control. The gain control adjusts the amount of signal required to drive the amplifier to full output. With the gain at full clockwise rotation, less signal voltage is required to drive the amp to full output. With the gain at full counter clockwise rotation, more signal voltage is required to drive the amp to full output. For optimal performance, set the gain control to minimum

High Pass Filter (HPF)

The high pass crossover/filter is designed to remove low frequency information from a speaker. This is generally used to protect smaller devices from trying to reproduce low frequency information that might damage them. The crossover frequency is adjustable from 50 Hz to 1KHz and uses 12 dB per octave slope. To engage the HPF simply slide the switch to the position on the marked HPF. Crossover frequency selection is made by rotating the dial: clockwise raises the frequency, counter-clockwise lowers the frequency. Most mid-bass or midrange drivers should be set between 80 and 400 Hz depending on how high the subwoofer(s) plays. For mid-range drivers that are 5" or smaller we suggest setting the HPF to 120Hz. The HPF can also be combined with passive crossovers on a separate or coaxial speaker set to provide low frequency protection to the midrange driver, or to form band-pass filter for a midrange speaker already using a passive low-pass filter.

Low Pass Filter (LPF)

The Lowpass crossover/filter is designed to remove high frequency information from a speaker. This is generally used to prevent mid bass speakers or subwoofers from trying to reproduce mid and high frequency information that they are not designed to reproduce. The crossover frequency is adjustable from 30Hz to 250Hz and uses a 12dB per octave slope. To engage the LPF slide the switch to the position marked LPF. Frequency selection is made by rotating the dial: clockwise raises the frequency and counter clockwise lowers the frequency. Most subwoofers should be set between 80Hz and 100Hz depending on how low the mid-bass or midrange drivers are capable of playing.

Full Range (MXA850.5M & MXA480.4M)

Sliding the selector switch to this position turns off all crossovers and allows a full range signal to pass. The flat position should be selected when using outboard electronic crossovers.

Bass Boost (45Hz)

Boost should be used with discretion, keeping in mind that electronically enhanced boost places an additional load on the amplifier and the speakers they are connected to. This control is fully variable from 0 - 12dB.

Sub Sonic Filter (MXA850.1m & MXA600.1M)

This filter is fully variable from 15Hz-50Hz and removes unwanted frequencies below the frequency selection. This filter is most useful with subwoofers loaded in a ported enclosure, which helps prevent unloading (rapid loss of power handling below the port tuned frequency).

End Panel Connections

Use only "MXA" Remotes for this amplifier model. The adjustment will increase/decrease the output level of the amplifier. The remote controller operates the level of the MXA600.1M and only the subwoofer channel of the MXA850.5M.

Input Mode Switch: (MXA850.5M) Place the switch on the number of audio inputs being used. F = FRONT R=REAR S=SUB.

Signal Input Connections

MXA850.5M

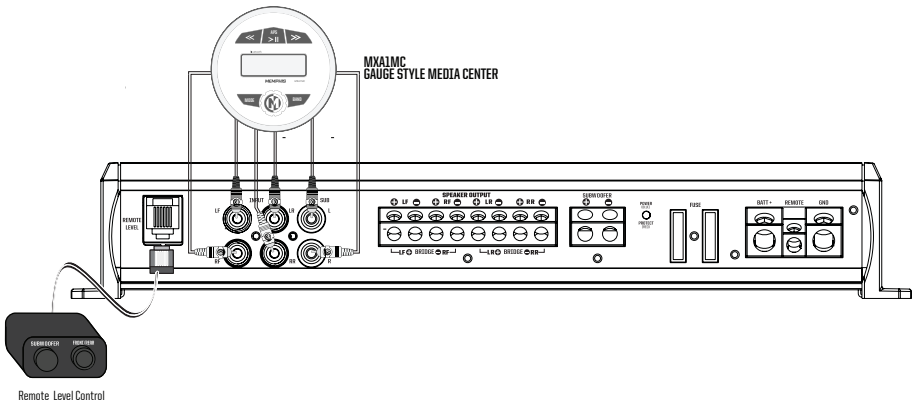

MXA480.4M

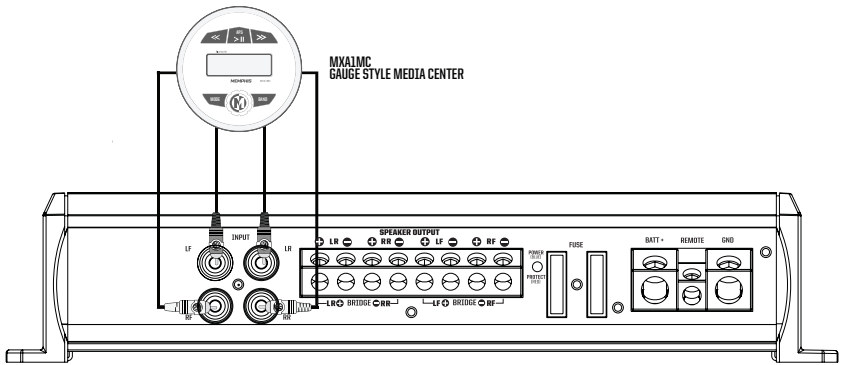

MXA600.1M

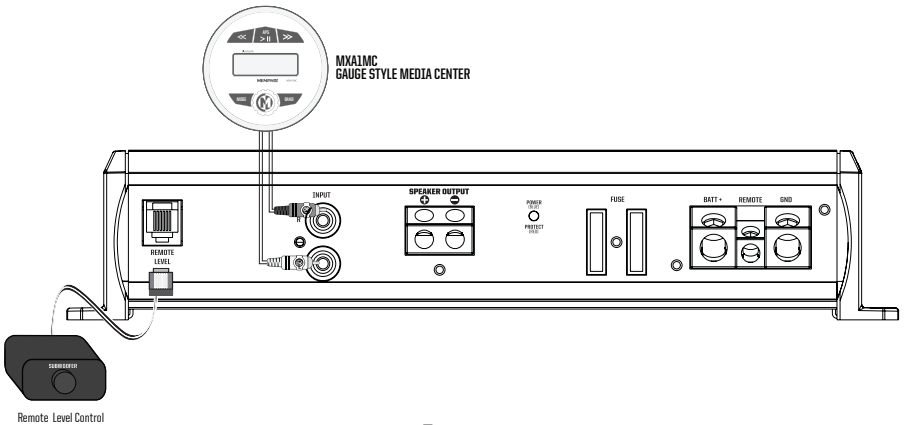

Speaker/Subwoofer Wiring

Speakers have a positive and negative marking on the terminals. These are used to indicate polarity and must be considered when wiring speakers or subwoofers to an amplifier. Amplifiers also have positive and negative markings on their speaker outputs. Use these markings to match polarities to ensure the speakers are in phase. Failure to wire speakers or woofers in phase with one another will result in a loss of bass. All MXA amplifiers require a minimum 2ohm impedance in stereo or 4 ohms in mono (bridged) mode.



Always check your speaker load with a multi-meter before hooking them up to the amplifier. The MXA480.4M amplifier is stable to 2 ohms stereo or 4 ohms bridged mono. The MXA850.5M amplifiers are stable to 2 ohms stereo or 4 ohms bridged mono (front & rear channels) and stable to 1 ohm (sub channel). The MXA600.1M is 1Ω Stable. Any Impedance (load) smaller than what is recommended will damage the amplifier! Such damage is not covered under warranty, so pay strict attention to what connections are made to the amplifier.

MXA850.5M

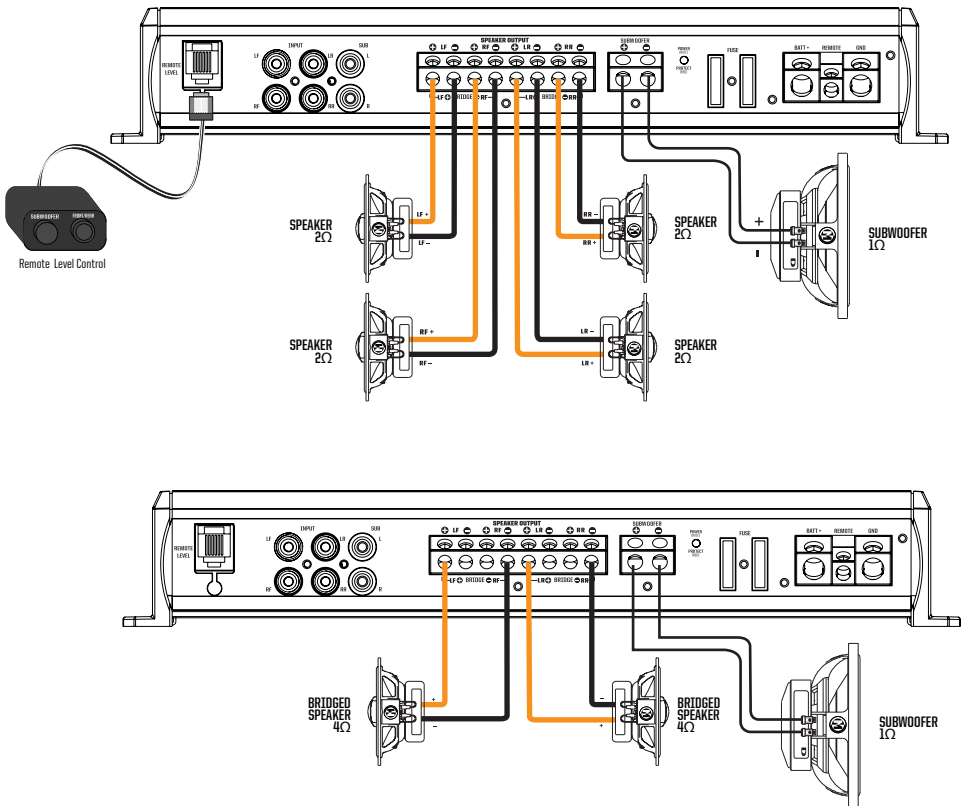

MXA480.4M

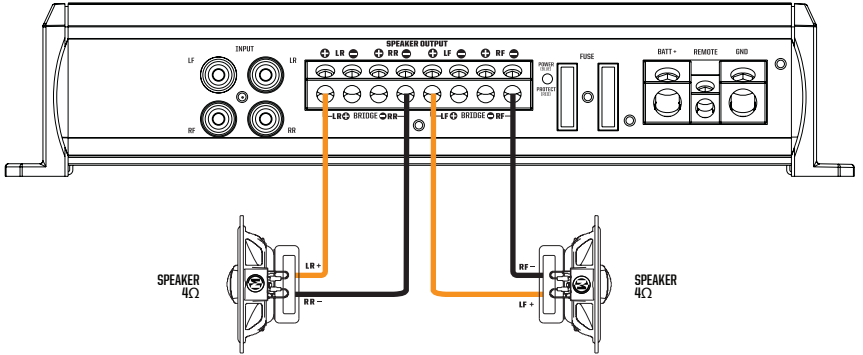
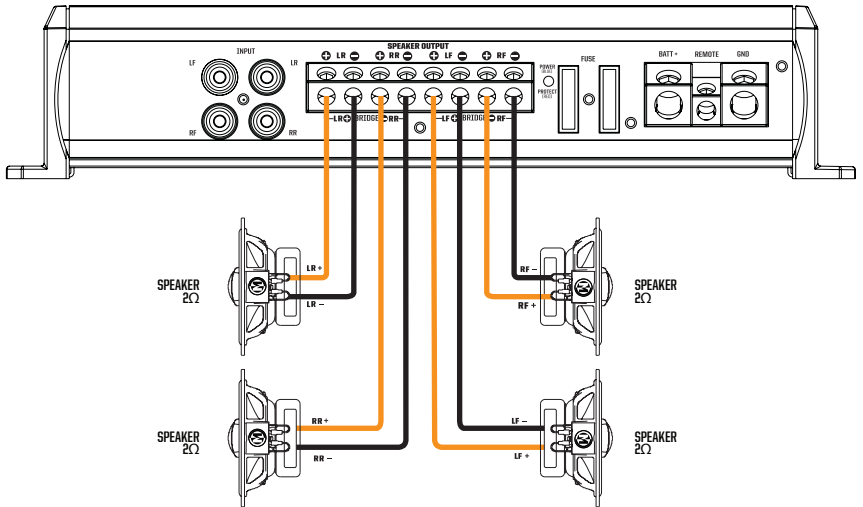

MXA600.1M

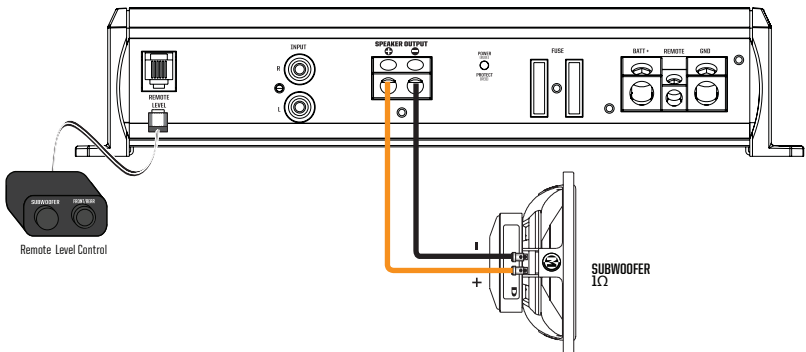



MEMPHIS
XTREME AUDIO

CONTACT INFO



122 GAYOSO AVE, MEMPHIS TN 38101



TECH SUPPORT 800-903-6979

SHOW US YOUR INSTALL & FOLLOW US TODAY!



WWW.MEMPHISCARRAUDIO.COM



[@MEMPHISCARRAUDIO](https://www.facebook.com/MEMPHISCARRAUDIO)



[@MEMPHISCARRAUDIO](https://www.instagram.com/MEMPHISCARRAUDIO) SA