



Final trim size: 8.268 x 11.22 in.
(210 x 285 mm)



USER GUIDE

18 Cu. Ft. Top Mount Refrigerator

NS-RTM18WH2 / NS-RTM18SS2 / NS-RTM18SS2L /
NS-RTM18BK2 / NS-RTM18BK2L

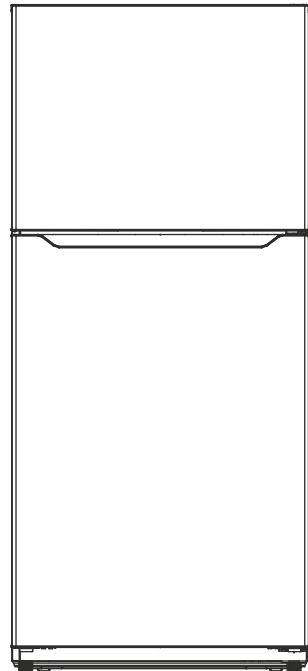

Before using your new product, please read these instructions to prevent any damage.
The most up-to-date User Guide is available from www.bestbuy.com



Contents

- Features4
- Important Safety Instructions3
- Features6
 - Package contents4
 - Main components.....5
- Setting up your refrigerator5
 - Before using your refrigerator5
 - Finding a suitable location6
 - Leveling your refrigerator6
 - Providing a proper power supply7
 - Installing an optional ice maker.....7
- Reversing the door position8
 - Preparing to reverse the door position8
 - Reversing the door position9
- Using your refrigerator16
 - Setting the temperature.....16
 - Using your refrigerator compartment16
 - Using your freezer compartment17
 - Dismissing the open door alarm18
 - Entering standby mode18
- Cleaning and maintaining your refrigerator19
 - Cleaning the interior19
 - Cleaning the exterior.....19
 - Defrosting the freezer19
 - Changing the interior LED light.....19
 - Shutting down your refrigerator for several months20
 - Handling power outages20
- Moving your refrigerator20
- Tips on saving energy20
- Obtaining replacement parts20
- Troubleshooting21
 - Understanding error codes21
 - Common problems and solutions21
- Specifications25
- ONE-YEAR LIMITED WARRANTY26



Introduction

Congratulations on your purchase of a high-quality Insignia product. Your NS-RTM18WH2, NS-RTM18SS2, NS-RTM18SS2L, NS-RTM18BK2, or NS-RTM18BK2L represents the state of the art in refrigerator design and is designed for reliable and trouble-free performance.

Important Safety Instructions

Read all instructions before use.

Keep these instructions.

For your safety and correct usage, please read these instructions carefully before using your new appliance to avoid unnecessary mistakes and accidents. Please ensure that all persons using this appliance are familiar with its operation and safety features. Keep these instructions in a safe place for future reference and be sure that they are kept with the appliance in the event that it is moved or sold, so that everyone using it through its life will be properly informed on its correct usage and safety. The manufacturer is not responsible for damages caused by misuse. The appliance is for indoor and domestic use only.

WARNING: Risk of fire/flammable materials

- Keep ventilation openings, in the appliance enclosure or in the built-in structure, clear of obstruction.
- Do not use mechanical devices or other means to accelerate the defrosting process, other than those recommended by the manufacturer.
- Do not damage the refrigerant circuit.
- Do not use electrical appliances inside the food storage compartments of the appliance, unless they are of the type recommended by the manufacturer.
- If the SUPPLY CORD is damaged, it must be replaced by the manufacturer, its service agent, or a similarly qualified person in order to avoid a hazard.
- The appliance contains a small quantity of refrigerant (R600a) which is environmentally friendly but potentially flammable in the refrigerant circuit.
- Do not locate multiple portable socket-outlets or portable power supplies at the rear of the appliance.
- Do not use extension cords or ungrounded (two prong) adapters.
- Unplug the refrigerator before carrying out user maintenance on it.

WARNING: Safety for children and other who are vulnerable

- This appliance is not intended for use by persons (including children) with reduced physical, sensory, or mental capabilities, or lack of experience and knowledge, unless they have been given supervision or instruction concerning the use of the appliance by a person responsible for their safety. Children should be supervised to ensure that they do not play with the appliance.
- Keep all packaging away from children to avoid risk of suffocation.
- Never allow children to play with, operate, or crawl inside the refrigerator. Risk of child entrapment. Before you throw away your old refrigerator:
 - 1) Take off the door
 - 2) Leave the shelves in place so that children may not easily climb inside
 - 3) Have the refrigerant removed by a qualified service technician
- The gaps between refrigerator doors and between doors and refrigerator body are small, do not put your hand in these areas to prevent from squeezing fingers. Please be gentle when closing the refrigerator door to avoid falling articles.

 **WARNING: General safety and daily use**

- This appliance is intended to be used in household and similar applications such as:
 - 1) Staff kitchen areas in shops, offices, and other working environments
 - 2) Farm houses and by clients in hotels, motels, and other residential-type environments
 - 3) Bed and breakfast environments
 - 4) Catering and similar non-retail applications
- Do not store explosive substances, such as aerosol cans with flammable propellant, in this appliance.
- Do not place the appliance in direct sunlight.
- Do not operate any electrical appliances within the appliance (such as electric ice cream makers, mixers, etc.).
- Do not store flammable gases or liquids inside the refrigerator. There is a risk of an explosion.
- Do not pick up foods or containers with wet hands in the freezing chamber when the refrigerator is running, especially metal containers, in order to avoid frostbite.
- Unplug this appliance during lightning storms or when it will not be used for long periods of time.
- Unplug the power cord by holding the plug, never by pulling the cord.
 - When optional ice maker is installed:
 - 1) Minimum/Maximum inlet water pressure, 138/827 kPa (20/120 PSIG).
 - 2) Connect to potable water supply only.

 **WARNING: Disposal of the appliance**

- It is prohibited to dispose of this appliance as household waste.
- Refrigerators contain refrigerant and gases in the insulation. Refrigerant and gases must be disposed of professionally as they may cause eye injuries or a fire hazard. Make sure that the refrigerant tubing is not damaged prior to proper disposal.
- Packaging materials with the recycle symbol are recyclable. Dispose of the packaging into a suitable waste collection container to recycle it. Before disposing of this appliance:
 - 1) Unplug it.
 - 2) Cut off and discard the power cord.

Features

- 18 cu. ft. capacity
- Glass shelves
- Two humidity-controlled crisper drawers
- LED lighting
- Frost free
- Reversible door with self-closing hinge
- Ice-maker ready (compatible with NS-ICEF2W2)

Package contents

- 18 cu. ft. top mount refrigerator
- Hinge kit (for door reversal)
- *User Guide*

Main components

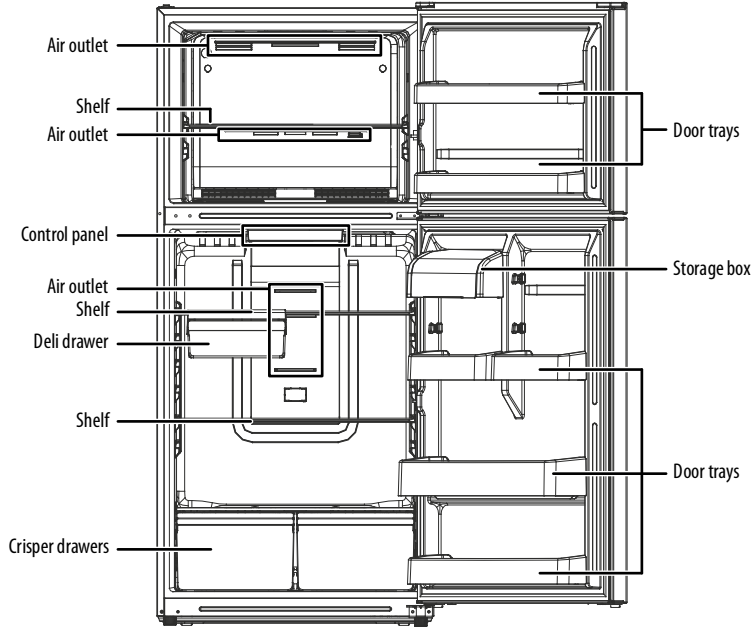

Note: The image above is only for reference and may vary from the actual product.

Setting up your refrigerator

Before using your refrigerator

- 1 Remove all packing materials, including bottom cushions, foam pads, and tape inside of your refrigerator. Tear off the protective film on the doors and the refrigerator body.
- 2 Wipe the cabinet with a mild detergent and warm water, then wipe dry.
- 3 Let the refrigerator stand upright for more than two hours before connecting it to power. Plugging in the refrigerator before this could result in a decrease in cooling capacity or other damage.
- 4 Before putting food in your refrigerator, wait about two to three hours after the thermostat has been set to let the refrigerator cool. In the summer (when the ambient temperature is high), wait four hours.

Finding a suitable location

- Position the refrigerator away from heat and direct sunlight. For the best performance, install in an area with an ambient temperature between 50° F (10° C) and 110° F (43° C).
- To prevent rust and to protect the electrical insulation, do not place the refrigerator in moist areas.
- Place your refrigerator in a well-ventilated indoor location. Leave at least 11 13/16 in. (30 cm) of space above and at least 3 15/16 in. (10 cm) behind and beside the refrigerator for heat dissipation.
- Make sure that the floor is flat and strong enough to support the refrigerator when fully loaded.
- Leave enough space to open the refrigerator's doors and drawers.

Leveling your refrigerator

- It is very important for the refrigerator to be level. If the refrigerator is not leveled during installation, the doors may not close or seal properly, causing cooling, frost, or moisture problems.
- To level your refrigerator, rotate the front leveling feet clockwise (to raise) the refrigerator or counter-clockwise (to lower).

Note: Having someone push against the top of the refrigerator helps to take some weight off the leveling foot, making it easier to adjust.

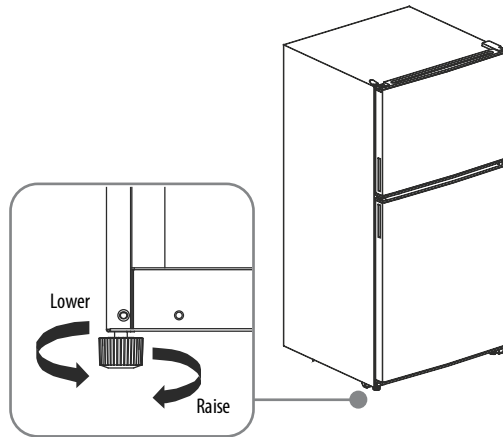

Providing a proper power supply

Check your local power source. This refrigerator requires a 110V–120V, 60Hz power supply.

Use a receptacle that accepts the grounding prong. The power cord is equipped with a 3-prong (grounding) plug which mates with a standard 3-prong (grounding) wall outlet to minimize the possibility of electric shock hazard from this refrigerator.

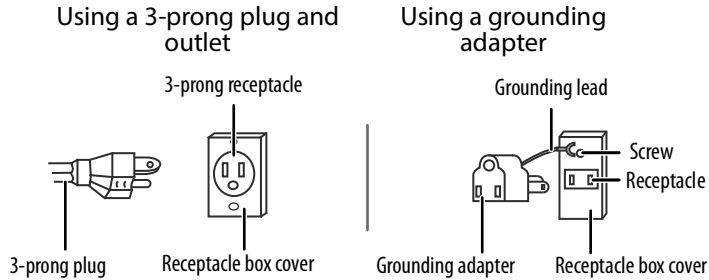

Notes:

- The refrigerator should always be plugged into its own individual electrical outlet which has a voltage rating that matches the rating plate.
- Never unplug your refrigerator by pulling on the power cord. Always grip the plug firmly and pull straight out from the outlet.

Installing an optional ice maker

The refrigerator comes set up for ice maker installation. This refrigerator is compatible with the Insignia NS-ICEF2W2 ice maker (not included).

Reversing the door position

Based on the location where you plan to use your refrigerator, you may find it more convenient to reverse the position of the door.

⚠ CAUTION

To avoid injury to yourself or your property, we recommend that someone assist you during the door reversal process.

Determining which version refrigerator you have

Before reversing the door position, check the version of your refrigerator to be sure that you have the parts listed below to proceed with the door reversal. To check your refrigerator version, look at the label on the inside left side of the refrigerator cabinet, if the label says "Rev A," contact Insignia Customer Service at 1-877-467-4289 to receive complimentary parts to complete the door reversal.

INSIGNIA™
MODEL: NS-RTM18SS2 Rev.B

Household Refrigerator
SERIAL NO.: 0000000000

SPECIFICATIONS	
LAMP RATED POWER	3W
HIGH SIDE / LOW SIDE	150psig / 60psig
REFRIGERANT / AMOUNT	R600a, 2.29oz(65g)
RATED VOLTAGE/ FREQUENCY	AC115V / 60Hz
TOTAL STORAGE VOLUME	18 cu.ft.
RATED CURRENT	1.2A
DEFROST POWER	215W
FOAMING AGENT	Cyclopentane
NET WEIGHT	166.4lbs(75.5kg)
W x D x H	29.7x30.7x66.6 in (75.5x78x169.2 cm)

HOUSEHOLD REFRIGERATOR
SA45210

Made in Thailand Insignia Service 1-877-467-4289 (U.S. and Canada)

Preparing to reverse the door position

Note:

- Images show a refrigerator that initially opens on the left side. However, your refrigerator may open on the right side.
- Models NS-RTM18WH2, NS-RTM18SS2, and NS-RTM18BK2 initially open on the left side. Models NS-RTM18SS2L and NS-RTM18BK2L initially open on the right side.

You will need:

- A flat-blade screwdriver and a Phillips screwdriver.
- To make sure that your refrigerator is unplugged and empty.
- To have someone available to assist you in the process.
- To keep all of the parts you remove to reuse them later.

Reversing the door position

Note: Left-opening model shown for illustration purposes.

Parts included with the hinge kit:

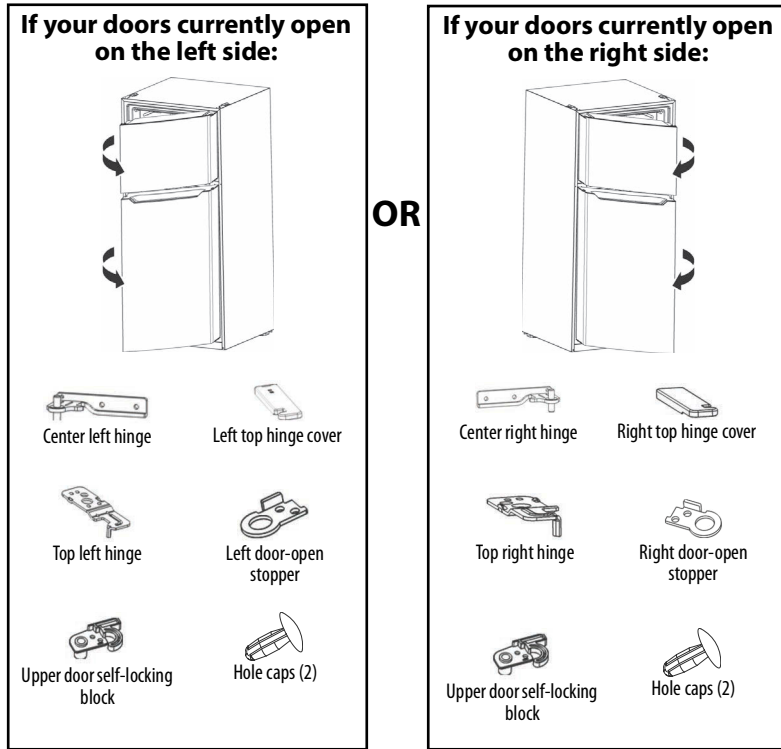

Parts you'll use that are already mounted on the door (as shipped):



- 1 Unplug your refrigerator and remove all food from the door shelves.

- Remove the cover plate and the top hinge cover, then unscrew and remove the top hinge. Keep the screws to reuse.

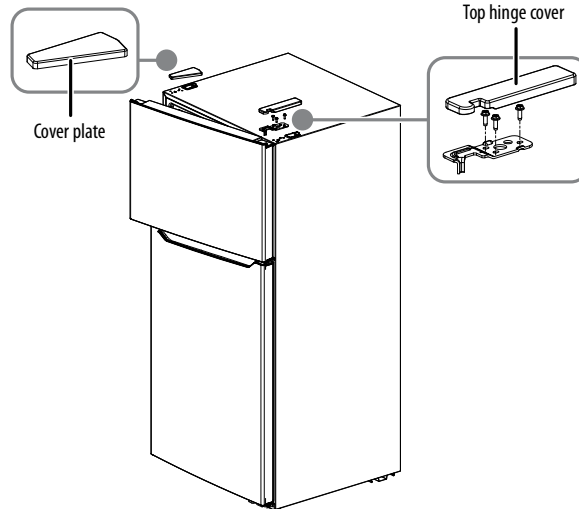

Note: Images show a refrigerator that opens on the left side. Your refrigerator may open on the right side.

- Lift the freezer door up and away from your refrigerator.
- Unscrew the three screws holding the center hinge, remove the hinge, then lift the refrigerator door up and away from your refrigerator. Remove the screw hole caps and hinge pivot from your refrigerator for reuse. Save the screws to reuse and store the hinge in a safe place in case you need to reverse the door position again.

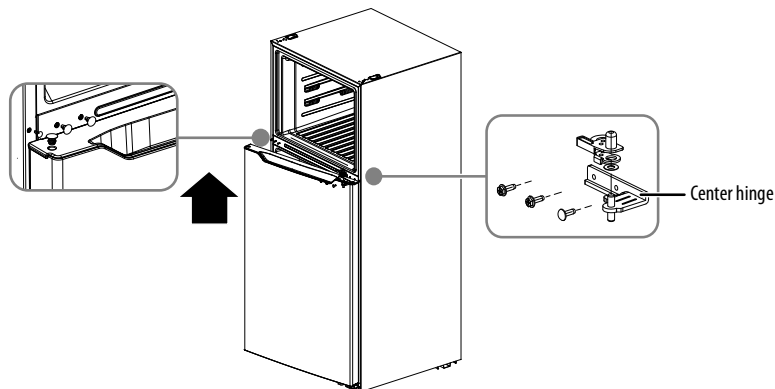

- 5 Unscrew the two screws holding the bottom hinge, then remove the bottom hinge from the refrigerator.

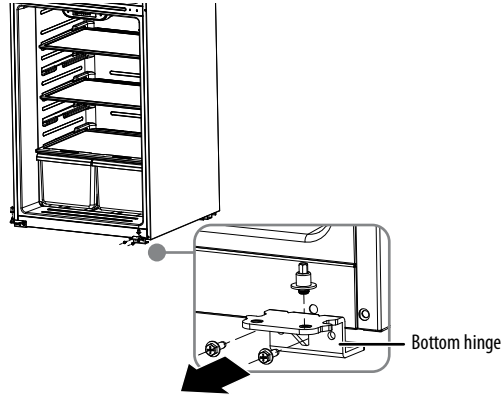

- 6 Unscrew the hinge pin from the bottom hinge and reattach it to the other hole in the hinge pin, then secure the bottom hinge to the opposite side of the refrigerator using the screws you removed previously.

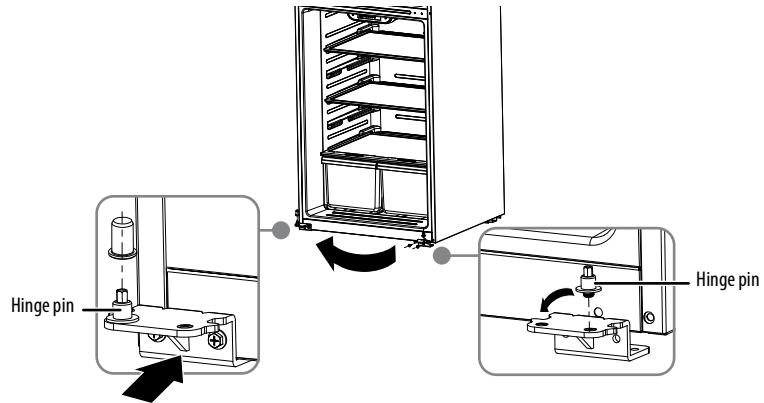

- 7 Remove the hole cap and plastic bushings from the top of the freezer and refrigerator doors. Save them for the next step.

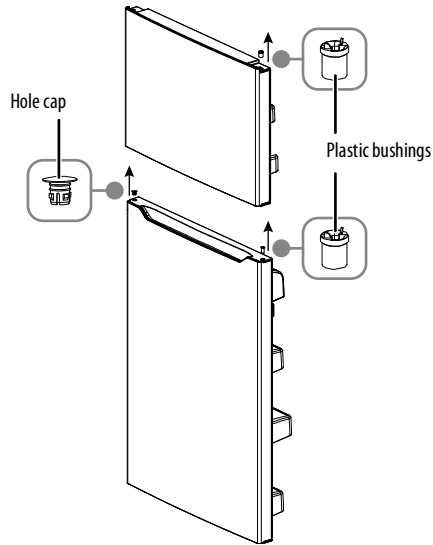

- 8 Insert the hole cap and plastic bushings into the opposite sides (from where you removed them) of the freezer and refrigerator doors.

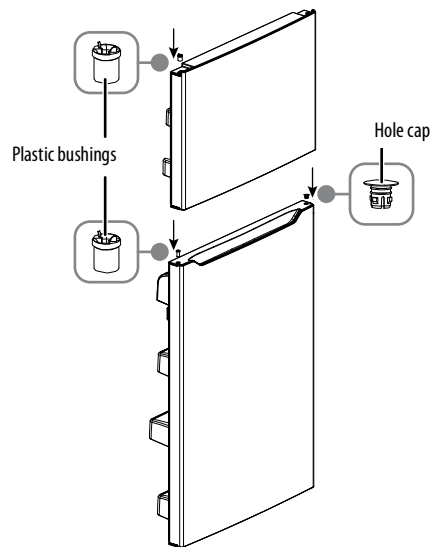

- 9 Flip the self-locking block over and attach it on the other side.

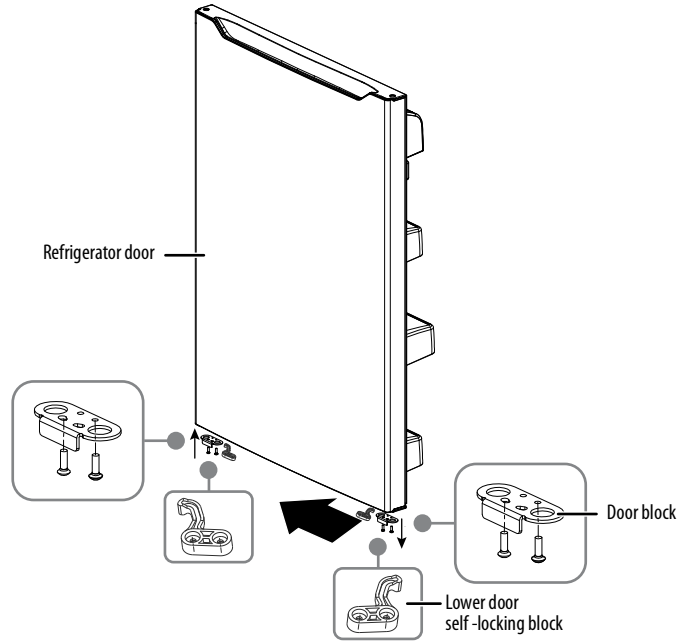

- 10 Use the upper hinge kit from the accessory parts to install the freezer door self-locking block and door stopper on the side where the hinge of the freezer door is located.

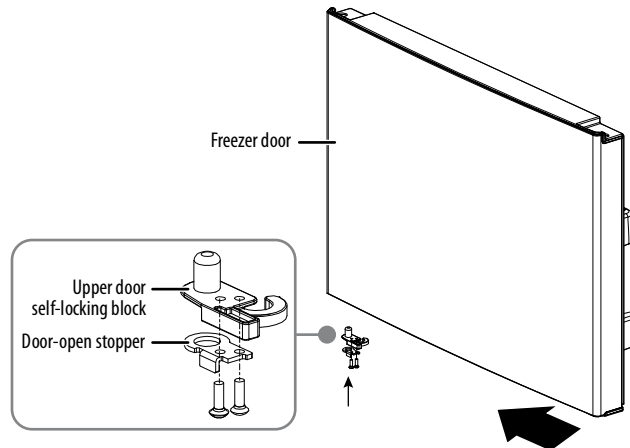

- 11 Remove the old upper door self-locking block and the door-open stopper (do not remove the parts attached in step 10). Store in a safe place in case you need to reverse the door position again.
- 12 Put the refrigerator door onto the bottom hinge, and then insert the middle hinge from the accessory package into the hinge shaft hole of the upper end cap of the refrigerator door. Then use the screws from step 4 to secure the hinge to the refrigerator.

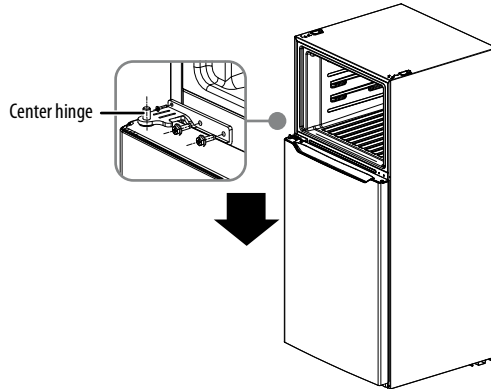

- 13 Put the freezer door onto the center hinge, then attach the top hinge (from the hinge kit) to the top of refrigerator. Cover the hinge with the top hinge cover (from the hinge kit) and cover the screw holes on the top with the cover plate you previously removed.

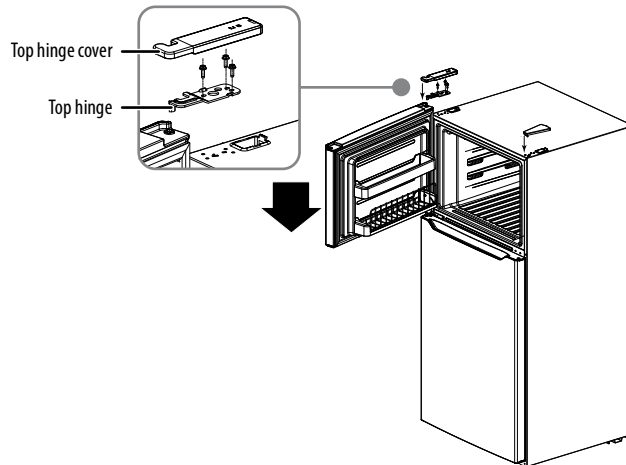

- 14** Add covers to the screw holes and hinge pivot.

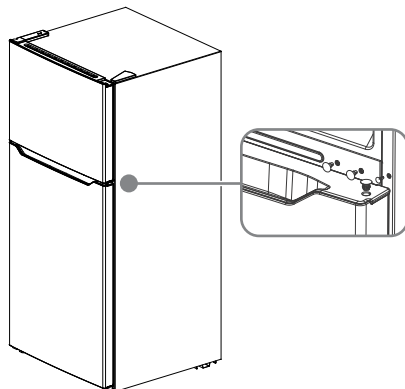

Using your refrigerator

After plugging in your refrigerator, you'll hear a beep and the refrigerator starts normal operation with the refrigerator and freezer set to the mid-range temperatures.

Note: If the refrigerator is unplugged, wait 10 minutes before restarting it to prevent damage to the compressor.

Setting the temperature

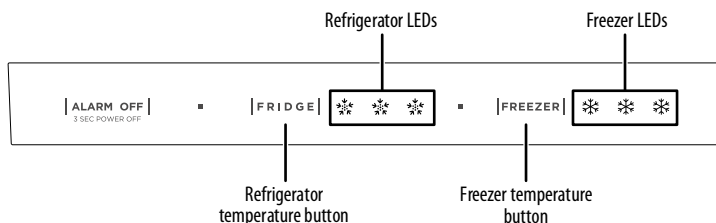

- To set the refrigerator temperature, press **FRIDGE** repeatedly to cycle through the three temperature settings. The refrigerator LEDs light up to show the current setting:
 - One LED ❄ illuminated: 46.4° F (8° C)
 - Two LEDs ❄ ❄ illuminated: 39.2° F (4° C)
 - Three LEDs ❄ ❄ ❄ illuminated: 35.6° F (2° C)
- To set the freezer temperature, press **FREEZER** repeatedly to cycle through the three temperature settings. The freezer LEDs light up to show the current setting:
 - One LED ❄ illuminated: 3.2° F (-16° C)
 - Two LEDs ❄ ❄ illuminated: -2.2° F (-19° C)
 - Three LEDs ❄ ❄ ❄ illuminated: -11.2° F (-24° C)

Note: If a fault occurs, the fridge and freezer LEDs will flash to show an error code instead of the current temperature setting. See "Understanding error codes" on page 21 for more information.

Using your refrigerator compartment

- The refrigerator compartment is suitable for storage of a variety of fruits, vegetables, beverages, and other food consumed in the short term.
- Do not place cooked foods in the refrigerator until they have cooled to room temperature.
- Wrap or seal foods in containers before putting them into the refrigerator.
- Adjust the glass shelves' position up or down to accommodate your stored foods.
- Large amounts of food will lower the cooling efficiency of the refrigerator. Do not block the air outlets.

CAUTION

To prevent damage, never close the refrigerator door while the shelves or crisper drawers are extended.

Using the refrigerator shelves

The two glass shelves in the refrigerator compartment can be adjusted to various heights, as needed.

- 1 To remove a shelf, lift the front of the shelf, then gently pull it forward until the shelf comes clear of the shelf guides.
- 2 When reinserting a shelf, make sure that there is nothing behind it, then gently push the shelf back into the position.

Using the crisper drawers

Use the crisper drawers to store vegetables and fruits. In general, store fruits and vegetables that are not sensitive to moisture loss (apples, peaches, pears) in a drawer with a low humidity setting and store food that can wilt (lettuce, asparagus, carrots, strawberries) in a drawer with high humidity.

The crisper cover controls the temperature of the crisper and prevents moisture loss. Use the sliding vents to adjust the humidity level inside each drawer.

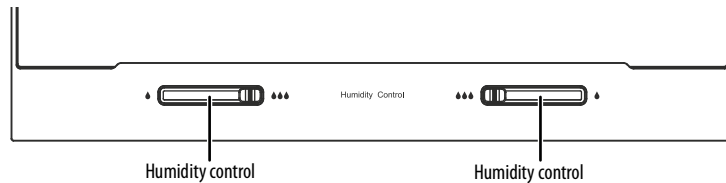

Using your freezer compartment

- The freezer compartment keeps food fresh for a long time, and it is mainly used to store frozen foods and ice.
- The freezing chamber is suitable for storage of meat, fish, ice cream, and other foods that won't be consumed in the short term.
- Divide chunks of meat into small pieces for easy access.
- Place frozen food into the freezer as quickly as possible after purchase.
- Follow package instructions regarding storage times. The storage life of frozen foods varies and the recommended storage time should not be exceeded.
- Large amounts of food will lower the cooling efficiency of the freezer. Do not block the air outlet.

Using the door trays

The refrigerator and freezer compartments have door trays. You can adjust a tray to fit the items you want to store.

- 1 Remove all items from a tray.

- 2 Hold the door tray with one hand, then use the other hand to tap the bottom of the tray up several inches.

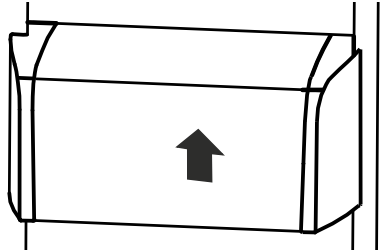

- 3 Align the door tray where you want to place it, then push it down into place.

Dismissing the open door alarm

When the refrigerator or freezer door is left open for two minutes, a buzzer sounds until you close the door.

To cancel the alarm without closing the door, press **ALARM OFF**.



Alarm off button

Entering standby mode

When in standby mode, the refrigerator stops refrigerating and the display is turned off.

- To enter standby mode, press and hold **ALARM OFF** for three seconds.
- To turn the refrigerator back on, press and hold **ALARM OFF** for three seconds.



Power on/off

Cleaning and maintaining your refrigerator

Your refrigerator is designed for year-round use with only minimal cleaning and maintenance.

When you first receive it, wipe the cabinet with a mild detergent and warm water, then wipe dry. Do this periodically to keep your refrigerator looking new.

CAUTION

- Do not use hard brushes, clean steel balls, wire brushes, abrasives (such as toothpastes), organic solvents (such as alcohol, acetone, banana oil, etc.), boiling water, acid or alkaline items, which may damage the fridge surface and interior. Boiling water and organic solvents such as benzene may deform or damage plastic parts.
- Do not rinse directly with water or other liquids during cleaning to avoid short circuits or affect electrical insulation after immersion.

Cleaning the interior

Clean the inside of the refrigerator and freezer regularly to avoid odor.

- 1 Before cleaning, unplug the refrigerator and remove all food, drinks, shelves, and drawers.
- 2 Mix two tablespoons of baking soda with a quart of warm water, then use a soft cloth or sponge to wipe the interior. Rinse with warm water and wipe clean.

Note: Do not use soap, detergent, scrub powder, or spray cleaners as these may cause odors inside the refrigerator or contaminate food.

- 3 Wipe the door trays, shelves, and drawers with a soft cloth dampened with soapy water or diluted detergent. Dry with a soft cloth or let it dry naturally.
- 4 Open the refrigerator door to let it dry completely before plugging in the refrigerator.

Cleaning the exterior

Note: The drain tray is located near the compressor. You do not need to empty or clean it.

- 1 Clean dust behind and underneath the refrigerator regularly to improve cooling and energy savings.
- 2 Make sure that there is no debris on the door gaskets. Clean with a soft cloth dampened with soapy water or diluted detergent.
- 3 Wipe the outer surface of the refrigerator with a soft cloth dampened with soapy water or detergent, and then wipe it dry.

Defrosting the freezer

This refrigerator is frost free, so you don't need to defrost it. If frost forms because of a change in season or temperature, you can manually remove it by unplugging the refrigerator or wiping with a dry towel.

Changing the interior LED light

The LED light is designed for a long life. It is not user serviceable and should be replaced by the manufacturer, its service agent, or a similarly qualified person.

Shutting down your refrigerator for several months

- 1 Turn off the refrigerator and unplug it from the wall outlet.
- 2 Remove all food.
- 3 Clean the refrigerator.
- 4 Leave the door open to avoid formation of condensation, mold, or odor.

 WARNING
--

Use extreme caution with children. The refrigerator should not be accessible to child's play.

Handling power outages

In case of a power outage, food inside your refrigerator can be kept for several hours (even during summer). While the power is out, keep the doors closed as much as possible, and do not add additional food.

Moving your refrigerator

- 1 Turn off the refrigerator and unplug it from the wall outlet.
- 2 Remove all food.
- 3 Securely tape down all loose items inside your refrigerator, such as the glass shelves and crisper drawers.
- 4 Tape the doors shut.
- 5 Hang the power cord on the plastic hook/holder on the rear/top side of the refrigerator, and tie it in place.
- 6 Tighten the front leveling feet (rotate counter-clockwise).
- 7 While moving, keep the refrigerator in an upright position and do not let it vibrate excessively. Do not tilt the refrigerator more than 45°.

Tips on saving energy

- Locate your refrigerator in the coolest area of the room, away from heat producing appliances or heating ducts and out of direct sunlight.
- Let hot foods cool before placing them in the refrigerator. Overloading the refrigerator forces the compressor to run longer. Foods that freeze too slowly may lose quality or spoil.
- Wrap foods properly and wipe containers dry before placing them in the refrigerator. This cuts down on frost buildup inside the refrigerator.
- Do not line storage bins with aluminum foil, wax paper, or paper towels. Liners interfere with cold air circulation, making the refrigerator less efficient.
- Organize and label food to reduce door openings and extended searches. Remove as many items as you can at one time, and close the door as soon as possible.

Obtaining replacement parts

Call Insignia Customer Service at 1-877-467-4289. To obtain replacement parts outside of the product warranty, visit <https://partstore.encompass.com> and search for the product model number.

Troubleshooting

Understanding error codes

When a fault occurs, the refrigerator alarm sounds and the fridge and freezer LEDs light up to show what the error is. Press **ALARM OFF** to turn off the alarm.

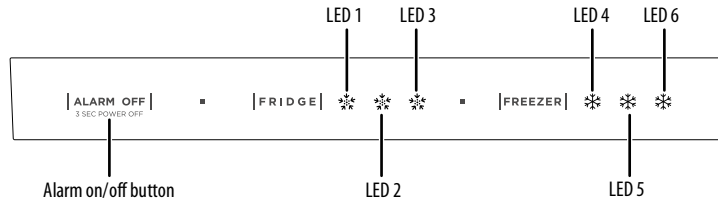

FAULT CODE	DESCRIPTION	SOLUTION
LED 5 & LED 6 flashing	Refrigerator temperature sensor fault	These are not user-serviceable errors. Contact a qualified service repair for additional help.
LED 2 & LED 6 flashing	Freezer temperature sensor fault	
LED 4 & LED 6 flashing	Defrost sensor fault	
LED 3 & LED 5 flashing	Control panel is not communicating with the processor	
LED 3 & LED 6 flashing	Ambient temperature fault	

Common problems and solutions

PROBLEM	POSSIBLE CAUSE	POSSIBLE SOLUTION
The refrigerator does not operate.	The refrigerator is unplugged.	Make sure that the refrigerator is plugged in and that the plug is pushed completely into the outlet.
	The voltage is too low.	Make sure that the refrigerator is plugged into a 110V–120V, 60Hz power outlet.
	Power failure.	If a power failure occurs, the refrigerator turns off. Wait until the power is restored.
	The refrigerator is in standby mode.	Press and hold ALARM OFF for three seconds to turn the refrigerator on.

PROBLEM	POSSIBLE CAUSE	POSSIBLE SOLUTION
The compressor turns on and off frequently.	The door has been opened too often or was not closed properly. The door seal may be dirty.	Make sure that the door is closed properly. Clean the door seal if necessary.
	The room temperature is hotter than normal.	This is normal, under the circumstances.
	A large amount of food was recently added to the refrigerator.	This is normal, under the circumstances. Let hot food cool before placing it inside the refrigerator.
	The thermostat is set too cold.	Set the thermostat to a warmer temperature.
	The refrigerator does not have the correct clearances.	Leave at least 11 13/16 in. (30 cm) of space above and at least 3 15/16 in. (10 cm) behind and beside the refrigerator for heat dissipation.
	The refrigerator has recently been disconnected for a period of time.	Allow up to four hours for the refrigerator to cool down completely.
Food in the refrigerator compartment is freezing.	The thermostat is set too cold.	Set the thermostat to a warmer setting.
	The ambient temperature is too low.	Move your refrigerator to a warmer area where the ambient temperature is between 50° ~ 110° F (10° ~ 43° C)
Food in the refrigerator compartment is not cold.	The door has been opened too often or was not closed properly.	Make sure that the door is closed properly.
	You have just added a large amount of food to the refrigerator or freezer compartments.	Allow time for the new food to cool, then check again. Let hot foods cool before placing them inside the refrigerator.
	The thermostat is set too warm.	Adjust the thermostat to a colder setting.
	The door gasket does not seal properly.	Clean the gasket.
	The refrigerator has recently been disconnected for a period of time.	Allow up to four hours for the refrigerator to cool completely.

PROBLEM	POSSIBLE CAUSE	POSSIBLE SOLUTION
The refrigerator makes unusual noises or vibrations.	The refrigerator may not be level on the floor.	Level the refrigerator with the leveling feet.
	The body of the refrigerator is touching a wall.	Move the refrigerator out from the wall.
	The compressor buzzes during operation (louder when turning on or off).	This is normal.
	Refrigerant is creaking or moaning.	This is a normal noise as the refrigerant passes through the cooling system.
	Accessories are misplaced.	Make sure that your refrigerator accessories are placed properly.
Moisture is building up in the interior of the refrigerator.	The door has been opened too often or was not closed properly.	Make sure that the door is closed properly.
	The refrigerator is in a location that is very humid.	Move the refrigerator to a dryer location.
	The food in the refrigerator is not packaged properly.	Repackage the food in the refrigerator to make sure that it is sealed.
Moisture is building up on the exterior of the refrigerator.	The door may be slightly open.	Make sure that the door closes completely.
	The humidity is high.	This is normal. Just wipe the condensation with a clean towel.
The refrigerator door does not close completely.	Food packages are interfering with the door.	Move the food packages or remove some food.
	The shelves are out of position.	Adjust the shelves properly.
	The door gaskets are dirty.	Clean the door gaskets.
	The refrigerator is not level.	Level the refrigerator with the leveling feet.
The exterior of the refrigerator is warm.	In the insulated walls of the refrigerator there is a heat exchanger coil. This produces heat.	This is normal. The longer your refrigerator runs the warmer the sides and top will get.
	The ambient temperature is too high.	Move the refrigerator to a cooler location.
	Too much food is being stored.	Remove some food from the refrigerator.
	The refrigerator does not have the correct clearances.	Leave at least 11 13/16 in. (30 cm) of space above and at least 3 15/16 in. (10 cm) behind and beside the refrigerator for heat dissipation.

PROBLEM	POSSIBLE CAUSE	POSSIBLE SOLUTION
The drip tray overflows.	There is too much food in the refrigerator, or the stored food contains too much water, causing heavy defrosting.	Remove excess food from the refrigerator.
	The doors are not properly closed.	Make sure that the door closes completely.
The door gasket (seal) is not tight.	The gasket is dirty.	Clean the door gaskets.
	The refrigerator is not level.	Use the front leveling feet to level your refrigerator.
	The door seal is aging.	Heat the door seal and then cool it to help restore the seal. (Use a hair dryer or hot towel for heating.)
The LED light doesn't turn on.	The refrigerator isn't connected to power.	Make sure that your refrigerator is connected to a working power outlet.
	The LED or door switch is defective.	Contact the manufacturer, its service agent, or a similarly qualified person to replace the LED.
The refrigerator has a bad odor.	Odorous foods are not wrapped properly.	Make sure that you seal your food properly.
	Food is rotting.	Remove rotten food from your refrigerator.
	The refrigerator is dirty.	Clean the refrigerator.
The temperature LEDs are blinking.	The refrigerator has a fault.	See " Understanding error codes " on page 21 for more information.

Specifications

Dimensions (H x W x D)	66 5/8 x 29 3/4 x 30 3/4 in. (169.2 x 75.5 x 78 cm)
Weight	Net weight: 153.23 lbs. (69.5 kg) Gross weight: 178.57 lbs. (81 kg)
Power requirements	115V~60Hz
Current	2.2A
Wattage	150W
Power consumption (annual)	369 kWh
Operating temperature	Refrigerator: 34° ~ 50° F (1 ~ 10° C) Freezer: -11° ~ 10° F (-24° ~ -12° C)
Ambient temperature range	50° ~ 110° F (10° ~ 43° C)
Power cord length	5.4 ft. (1.65 m)
Noise	43 dB
Energy Star certified	Yes

ONE-YEAR LIMITED WARRANTY

Best Buy, or its Authorized Partner of Insignia branded products, warrants to you, the original purchaser of this new Insignia branded product ("Product"), that the Product shall be free of defects in the original manufacture of the material or workmanship for a period of one (1) year from the date of your purchase of the Product or the date of delivery (if later than the date of purchase) ("Warranty Period").

For this warranty to apply, your Product must be (i) purchased in the United States or Canada from a Best Buy branded retail store, online at www.bestbuy.com or www.bestbuy.ca, or from Best Buy's Authorized Partner, and (ii) packaged or sold with this warranty statement.

The term "Best Buy", as used in this warranty, refers to Best Buy branded retail stores, www.bestbuy.com, www.bestbuy.ca, and Best Buy's Authorized Partner.

Because Insignia cannot control the quality of products sold by unauthorized sellers, this warranty applies only to Products that were purchased from Best Buy or an Insignia Authorized Partner, unless otherwise prohibited by law. Insignia reserves the right to reject warranty claims for Products purchased from unauthorized sellers, including unauthorized websites.

REPAIR OR REPLACEMENT, AS PROVIDED UNDER THIS WARRANTY, IS YOUR EXCLUSIVE REMEDY FOR BREACH OF WARRANTY. INSIGNIA SHALL NOT BE LIABLE FOR ANY INCIDENTAL OR CONSEQUENTIAL DAMAGES FOR THE BREACH OF ANY EXPRESSED OR IMPLIED WARRANTY ON THIS PRODUCT, INCLUDING, BUT NOT LIMITED TO, LOST DATA, LOSS OF USE OF YOUR PRODUCT, LOST BUSINESS, OR LOST PROFITS. INSIGNIA PRODUCTS MAKES NO OTHER EXPRESS WARRANTIES WITH RESPECT TO THE PRODUCT. ALL EXPRESSED AND IMPLIED WARRANTIES FOR THE PRODUCT, INCLUDING BUT NOT LIMITED TO ANY IMPLIED WARRANTIES OF AND CONDITIONS OF MERCHANTABILITY AND FITNESS FOR A PARTICULAR PURPOSE, ARE LIMITED IN DURATION TO THE WARRANTY PERIOD SET FORTH ABOVE AND NO WARRANTIES, WHETHER EXPRESSED OR IMPLIED, WILL APPLY AFTER THE WARRANTY PERIOD. SOME STATES, PROVINCES, AND JURISDICTIONS DO NOT ALLOW LIMITATIONS ON (i) HOW LONG AN IMPLIED WARRANTY LASTS, (ii) EXCLUSION OR LIMITATION OF INCIDENTAL OR CONSEQUENTIAL DAMAGES, or (iii) LIMITATION OF INCIDENTAL OR CONSEQUENTIAL DAMAGES, SO THE ABOVE LIMITATIONS OR EXCLUSIONS MAY NOT APPLY TO YOU. THIS WARRANTY GIVES YOU SPECIFIC LEGAL RIGHTS, AND YOU MAY ALSO HAVE OTHER RIGHTS, WHICH VARY FROM STATE TO STATE OR PROVINCE TO PROVINCE.

How long does the coverage last?

The Warranty Period lasts for 1 year (365 days) from the date you purchased the Product or the date of delivery (if later than the date of purchase). Your purchase date is printed on the receipt you received with the Product. In the event that Authorized Partner ceases to sell the covered Insignia branded product, this warranty shall terminate for that product and there shall be no repair or replacement of the Product.

What does this warranty cover?

During the Warranty Period, if the original manufacture of the material or workmanship of the Product is determined to be defective by an authorized Insignia repair center or store personnel, Insignia will (at its sole option): (1) repair the Product with new or rebuilt parts; or (2) replace the Product at no charge with new or rebuilt comparable products or parts. Products and parts replaced under this warranty become the property of Insignia and are not returned to you. If service of Products or parts are required after the Warranty Period expires, you must pay all labor and parts charges. This warranty lasts as long as you own your Insignia Product during the Warranty Period. Warranty coverage terminates if you sell or otherwise transfer the Product.

How to obtain warranty service?

If you purchased the Product at a Best Buy retail store location or from a Best Buy online website (www.bestbuy.com or www.bestbuy.ca), please take your original receipt and the Product to any Best Buy store. Make sure that you place the Product in its original packaging or packaging that provides the same amount of protection as the original packaging. If you purchased your Product from an Authorized Partner, call Insignia at 1-877-467-4289.

To obtain warranty service, in the United States and Canada call 1-877-467-4289. Call agents may diagnose and correct the issue over the phone.

If you purchased the Product from an Authorized Partner other than Best Buy, please call 1-888-BESTBUY in the United States or 1-866-BESTBUY in Canada. You will be asked to provide proof of purchase and to return your Product to Best Buy. Make sure that you put the Product in its original packaging or packaging that provides the same amount of protection as the original packaging.

Where is the warranty valid?

This warranty is valid only in the United States and Canada to the original purchaser of the product from an Authorized Partner, in the country where the original purchase was made.

What does the warranty not cover?

This warranty does not cover:

- Food, beverage, and or medicine loss/spoilage.
- Damage to other products caused by a power surge or other similar issue while connected to the Product.
- Customer instruction/education.
- Installation.
- Set up adjustments.
- Cosmetic damage.
- Damage due to weather, lightning, and other acts of God, such as power surges.
- Accidental damage.
- Misuse.
- Abuse.
- Negligence.
- Commercial purposes/use, including but not limited to use in a place of business or in communal areas of a multiple dwelling condominium or apartment complex, or otherwise used in a place of other than a private home.
- Modification of any part of the Product, including the antenna.
- Display panel damaged by static (non-moving) images applied for lengthy periods (burn-in).
- Damage due to incorrect operation or maintenance.
- Connection to an incorrect voltage or power supply.
- Damage due to attempted repair by any person not authorized by Insignia to service the Product.
- Products sold "as is" or "with all faults".
- Consumables, including but not limited to batteries (i.e. AA, AAA, C etc.).
- Products where the factory applied serial number has been altered or removed.
- Loss or Theft of this product or any part of the product.
- Display panels containing up to three (3) pixel failures (dots that are dark or incorrectly illuminated) grouped in an area smaller than one tenth (1/10) of the display size or up to five (5) pixel failures throughout the display. (Pixel based displays may contain a limited number of pixels that may not function normally.).
- Failures or Damage caused by any contact including but not limited to liquids, gels or pastes.

Contact Insignia:

1-877-467-4289

www.insigniaproducts.com

INSIGNIA is a trademark of Best Buy and its affiliated companies. *Distributed by Best Buy Purchasing, LLC

7601 Penn Ave South, Richfield, MN 55423 U.S.A

©2025 Best Buy. All rights reserved.



INSIGNIA™



For product inquiries, please contact us with the information below:

1-877-467-4289

www.insigniaproducts.com

INSIGNIA is a trademark of Best Buy and its affiliated companies.

Distributed by Best Buy Purchasing, LLC

7601 Penn Ave South, Richfield, MN 55423 U.S.A.

©2025 Best Buy. All rights reserved.

V3 ENGLISH
25-0651

