

ASSEMBLY INSTRUCTION

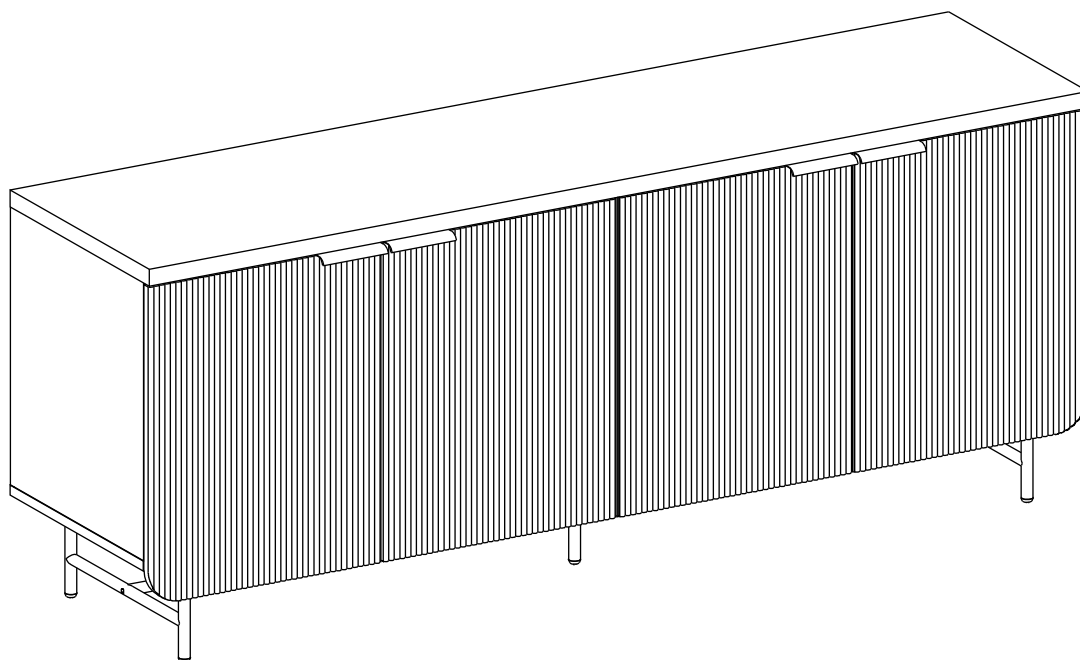

Know more about Bestier from



CUSTOMER SUPPORT

CONTACT US BY:
PHONE: 888-666-1086
EMAIL: Service@bestier.net

Thanks for choosing Bestier!
Feel free to contact us if you need any help.
Please kindly share your shopping experience
with us on the platform if you are satisfied with it.

General Assembly Guidelines

- I. Ensure that all parts and hardware are available before beginning assembly.
- II. Follow each step carefully to ensure the proper assembly of this product.
- III. Two people are recommended for ease in the assembly of this product.
- IV. The three main types of hardware used to assemble this product are: wood dowels, screws and bolts.
- V. The provided glue is to secure wood dowels in place. When first inserting dowels, locate the appropriate hole for the dowel, place a small amount of glue in the hole and insert the dowel. Wipe away excess glue immediately.

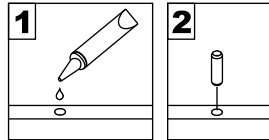

In future assembly steps when dowels are necessary to attach assembly parts together, place a small amount of glue on the end of the dowel before attaching parts together. Wipe away excess glue immediately.

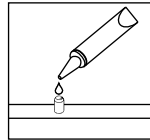

- VI. A Phillips head screwdriver is required for the assembly of this product.

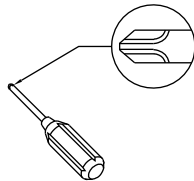

- VII. Power tools should not be used to assemble this product.

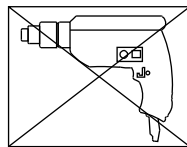

- VIII. Drill may be needed for securing product to wall.

- IX. Concealed hinges are three-way adjustable.

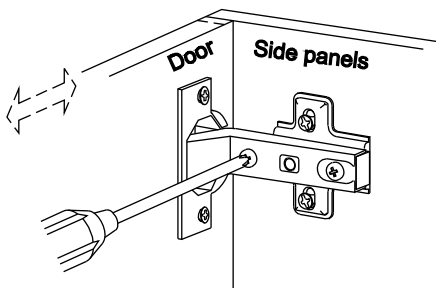

Horizontal
by screw adjustment

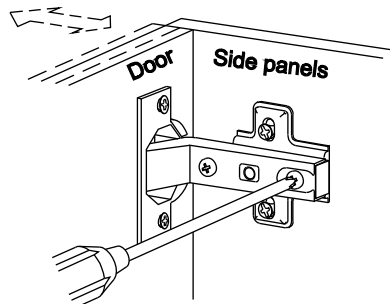

In-and-Out
by loosening the hinge-arm
mounting screw or via cam
adjustment

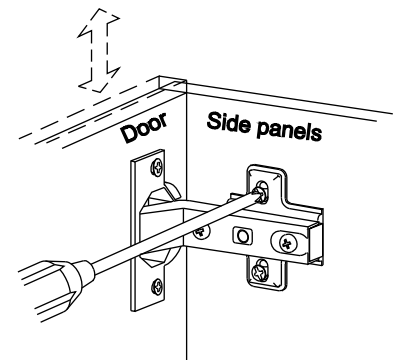





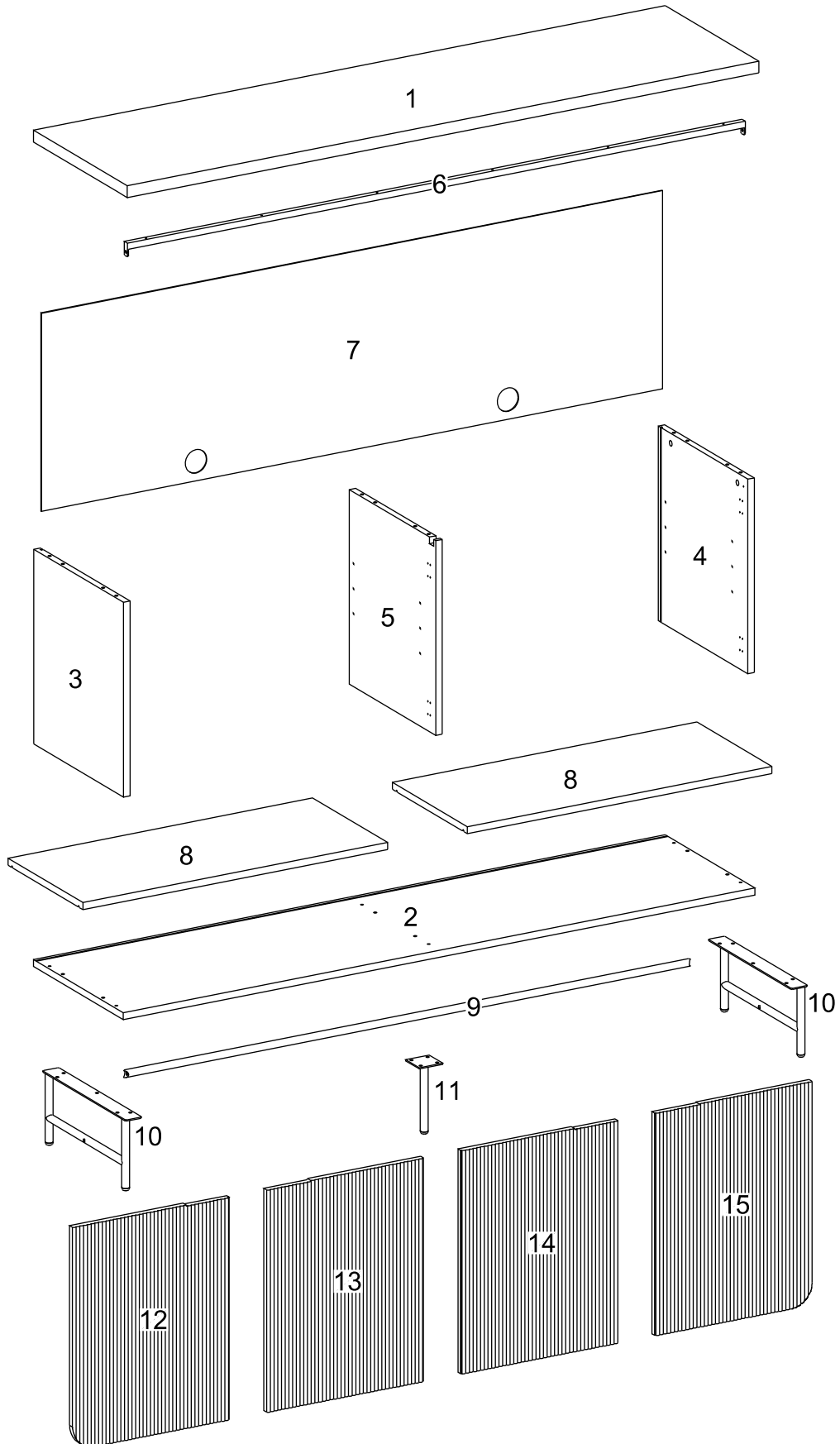

Vertical
Via slots in the mounting
plate or via cam adjustment

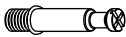

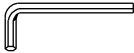
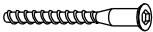



Parts List



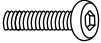

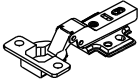
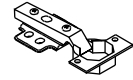
Hardware List

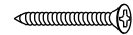
A		Ø8x30mm	Wooden dowel	12 pcs
B		Ø6x35mm	Cam bolt	6 pcs
C		Ø15x11mm	Cam lock	6 pcs
D		Ø30mm	Sticker	6 pcs
E		M 4	Hex key	1 pc
F		Ø6x50mm	Screw	6 pcs
G		Ø8x5x16mm	Shelf support pin	8 pcs
H			Plastic wedge	10 pcs
J		Ø3x17mm	Screw	10 pcs

Hardware List

K		M6x12mm	Bolt	14 pcs
L		M6x35mm	Bolt	2 pcs
M			Handle	4 pcs
N		Ø4x14mm	Screw	8 pcs
P		Ø35mm	Europe hinge	4 pcs
Q		Ø35mm	Europe hinge	4 pcs
R		Ø4x14mm	Screw	48 pcs
S		Ø4x32mm	Screw	6 pcs
T		Ø4x12mm	Screw	4 pcs

Hardware List

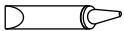
U		Ø4x25mm	Screw	2 pcs
V			Plastic strap	2 pcs
W			Nut	2 pcs
X			Glue tube	1 pc

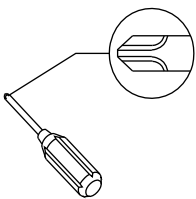

Phillips head screwdriver required for assembly
(not included)

The hardware quantities listed above are required for proper assembly. Some extra hardware may also have been included.

Step 1

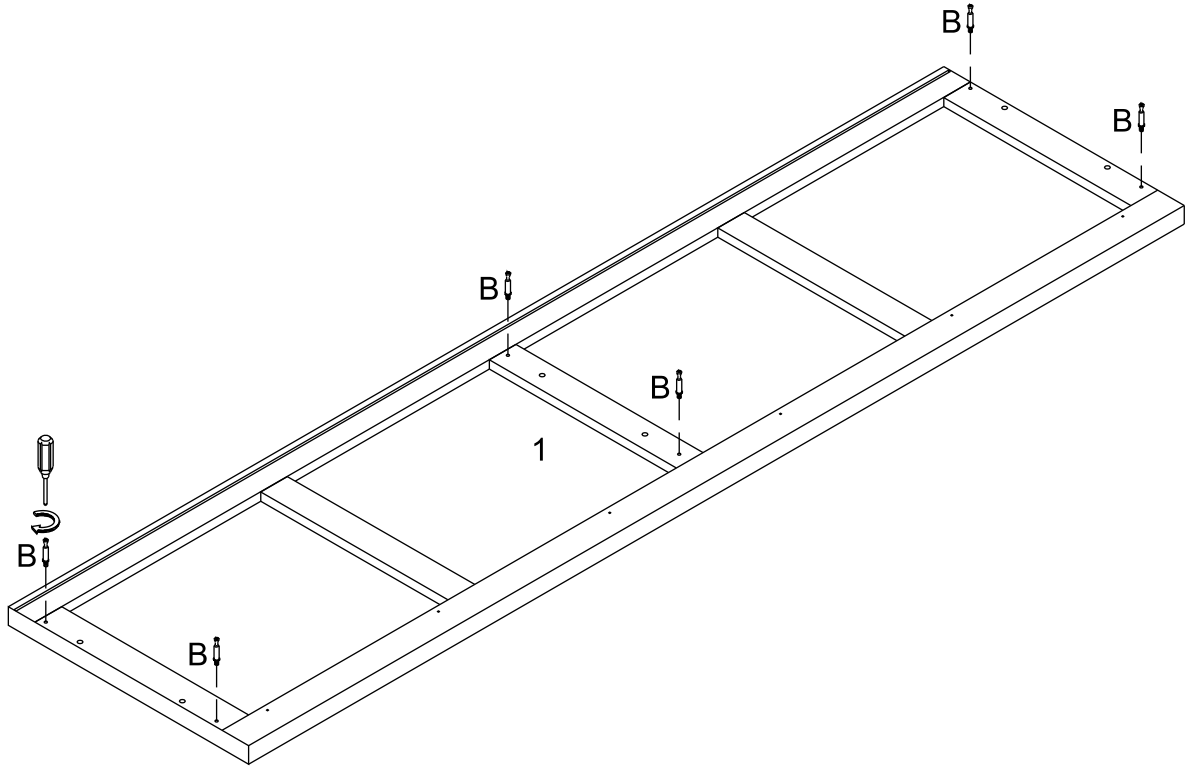

Secure Cam bolt (B) into part (1) with Phillips head screwdriver as per diagram.

Step 2

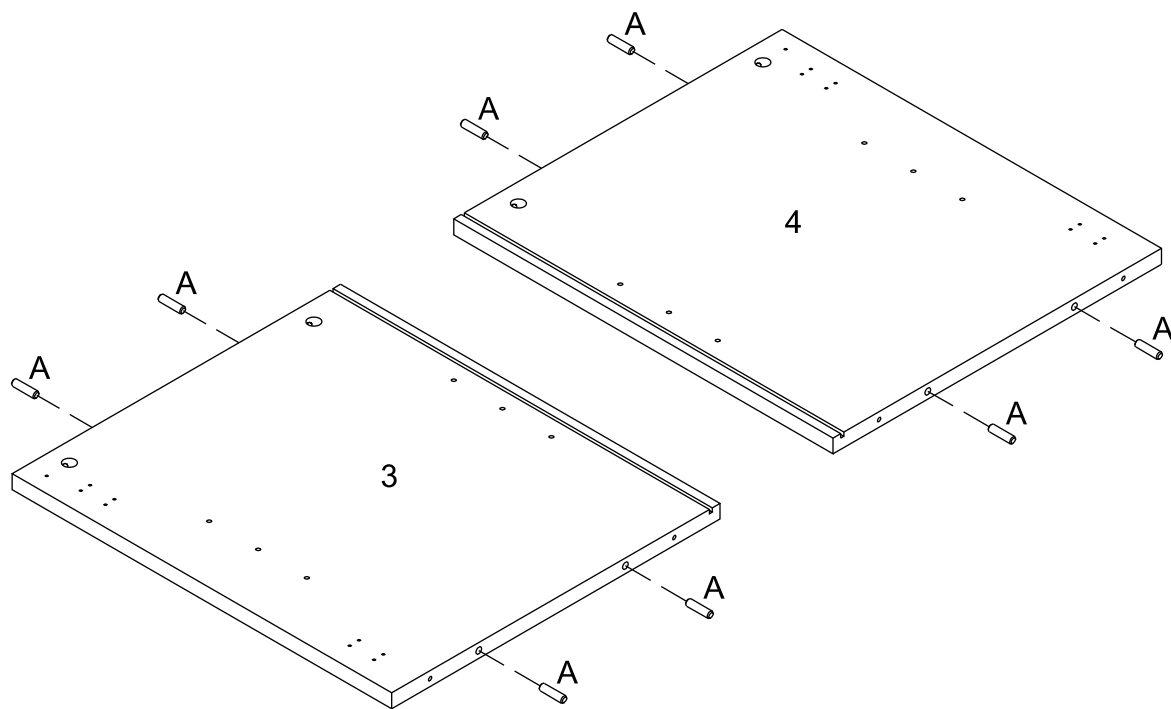

Insert wooden dowel (A) into part (3,4) as per diagram.

Step 3

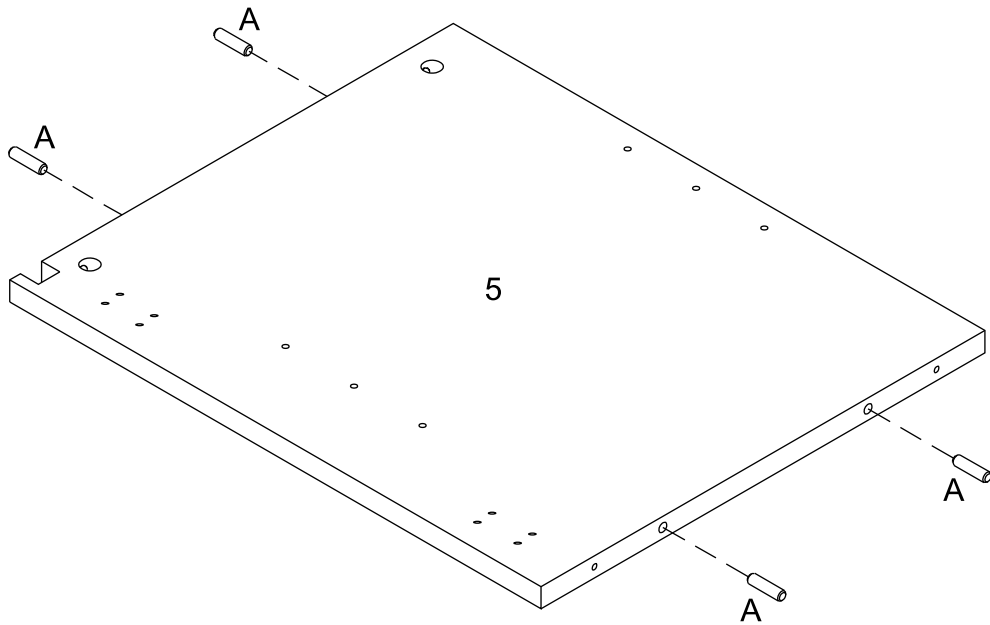

Insert wooden dowel (A) into part (5) as per diagram.

Step 4

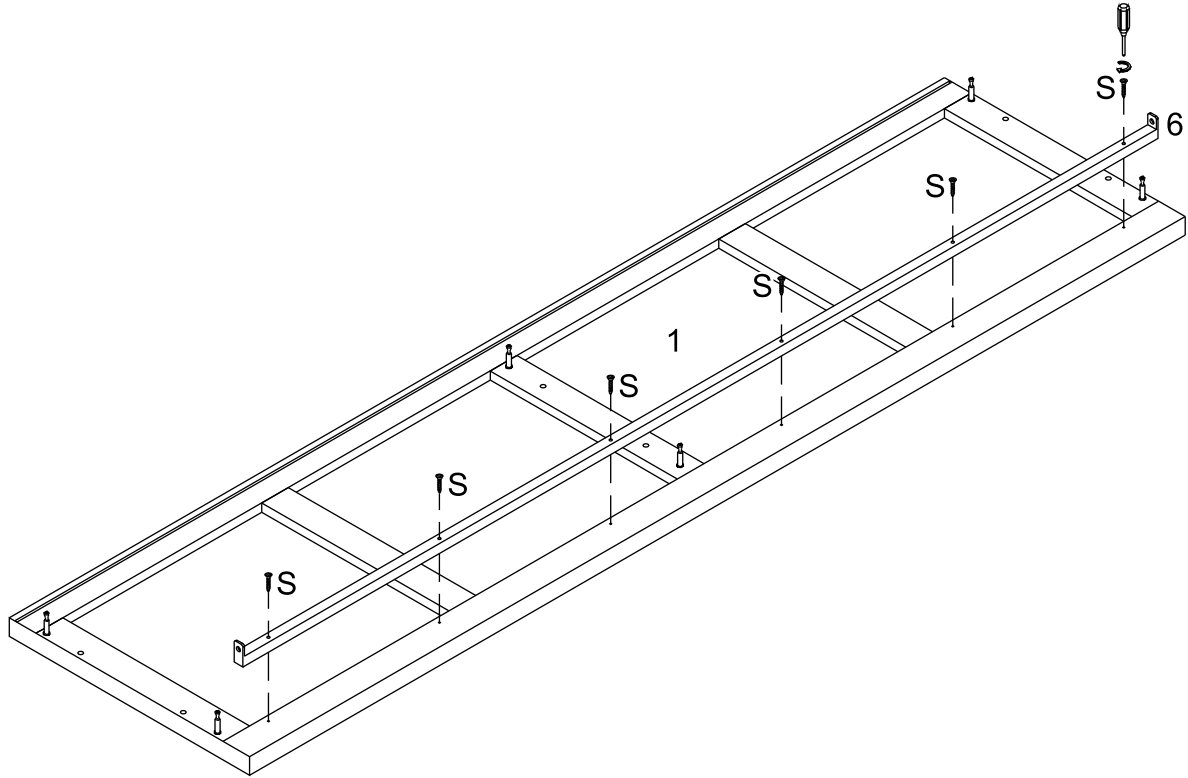

Using Screw (S) secure part (6) to part (1) with Phillips head screwdriver as per diagram.

Step 5

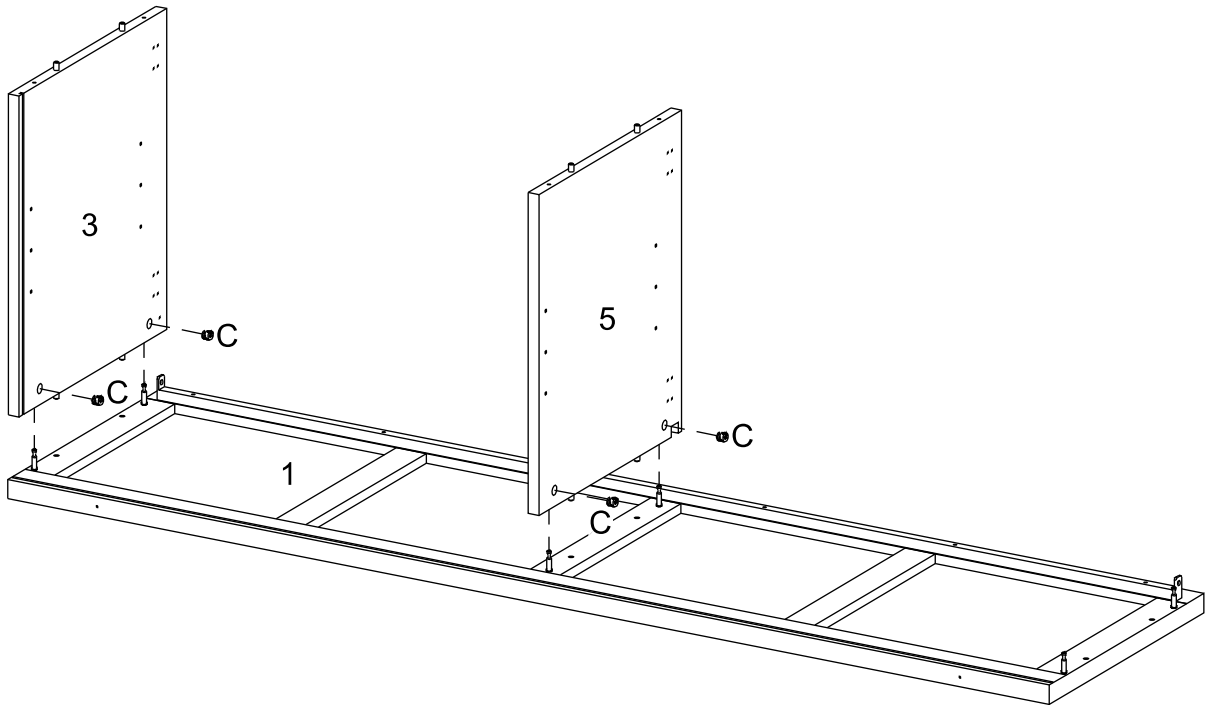
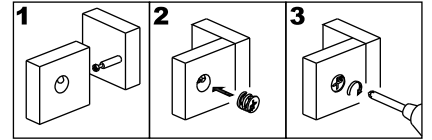

Attach part (3,5) to part (1), using Cam lock (C) secure part (3,5) to part (1) with Phillips head screwdriver as per diagram.

Step 6

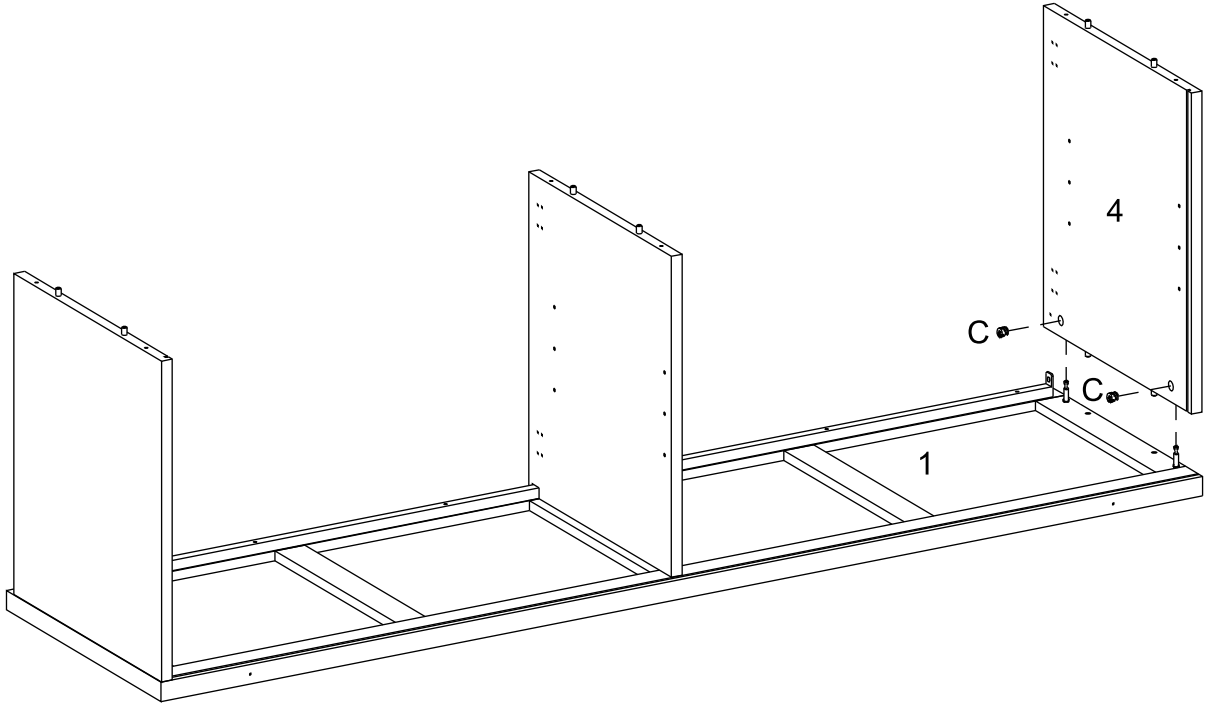
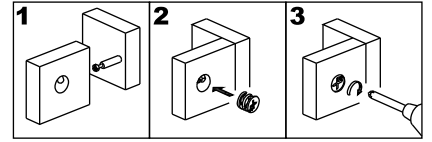

Attach part (4) to part (1), using Cam lock (C) secure part (4) to part (1) with Phillips head screwdriver as per diagram.

Step 7

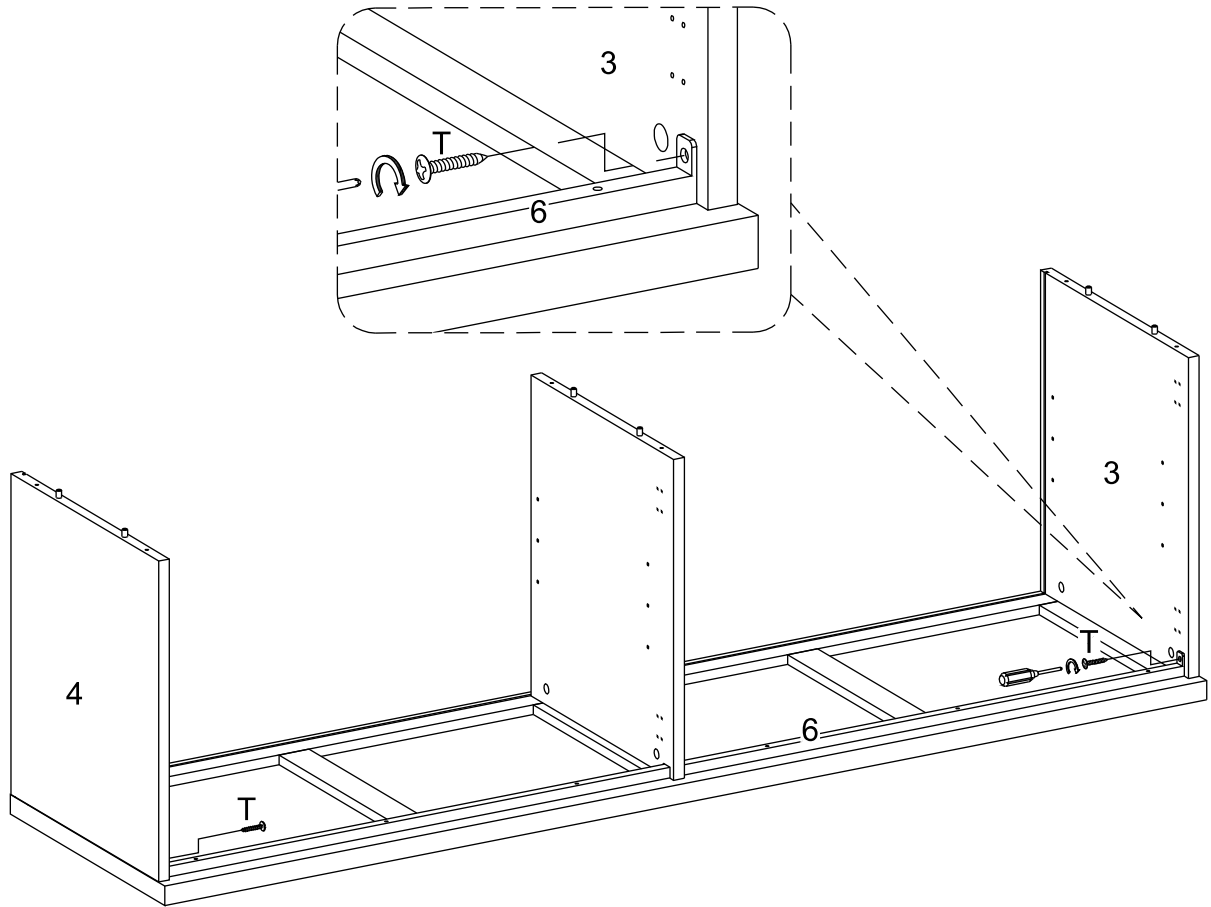

Using Screw (T) secure part (6) to part (3,4) with Phillips head screwdriver as per diagram.

Step 8

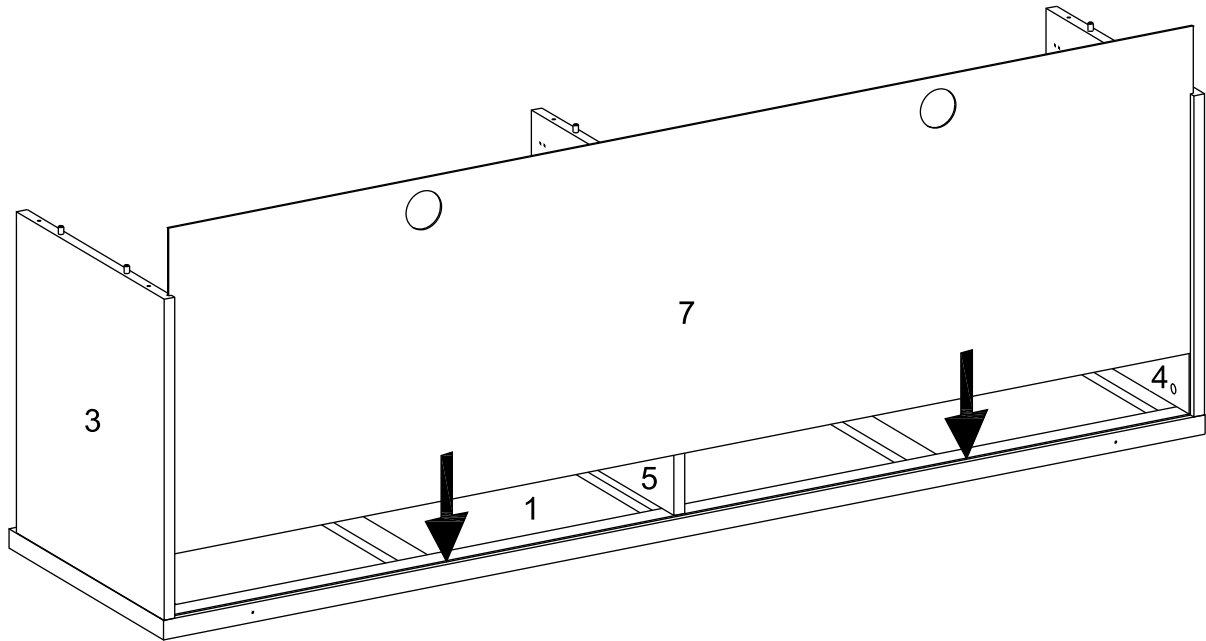

Place part (7) as per diagram.

Step 9

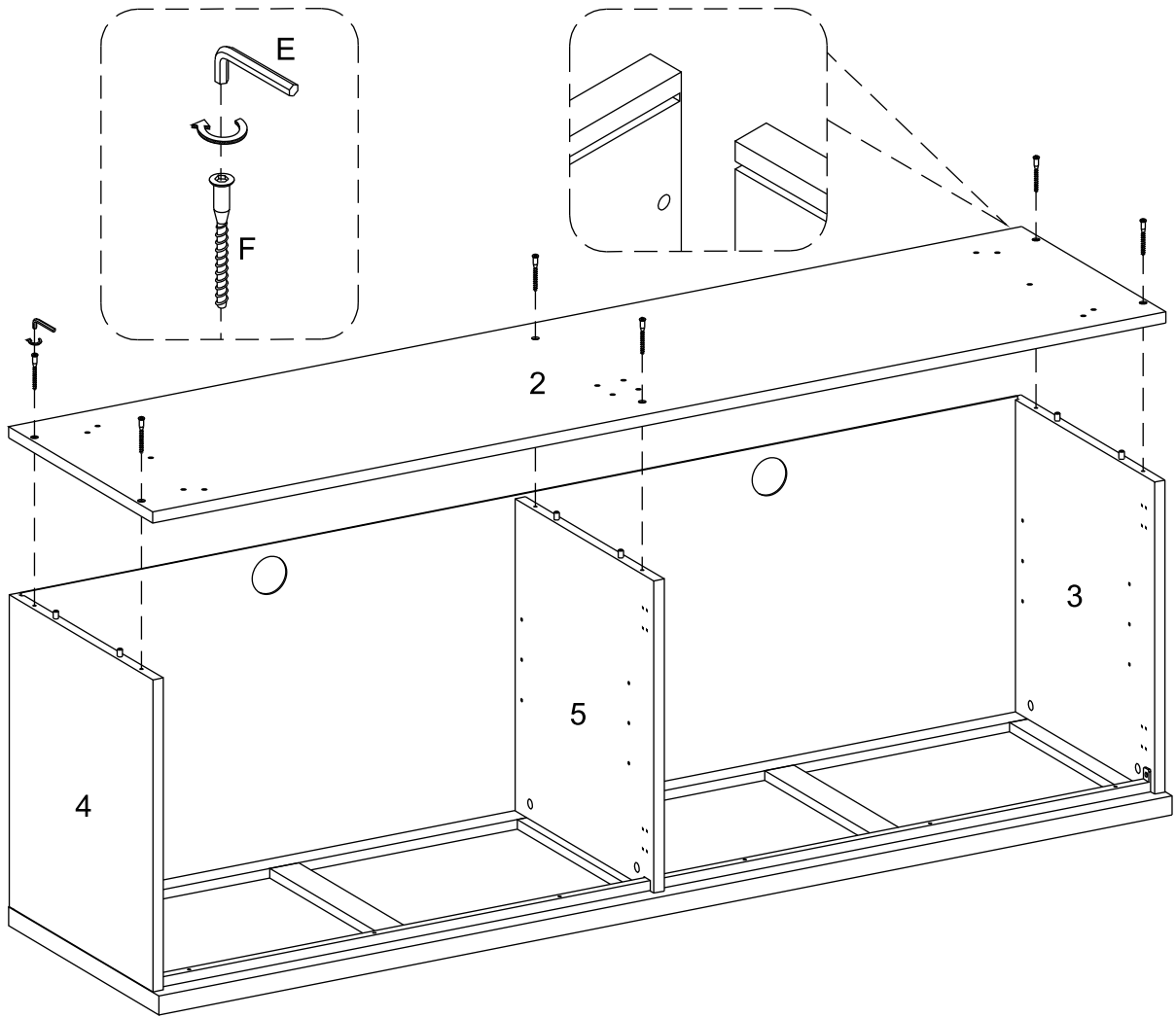

Attach part (2) to part (3,4,5), using Screw (F) attach part (2) to part (3,4,5) with Hex key (E) as per diagram.

Step 10

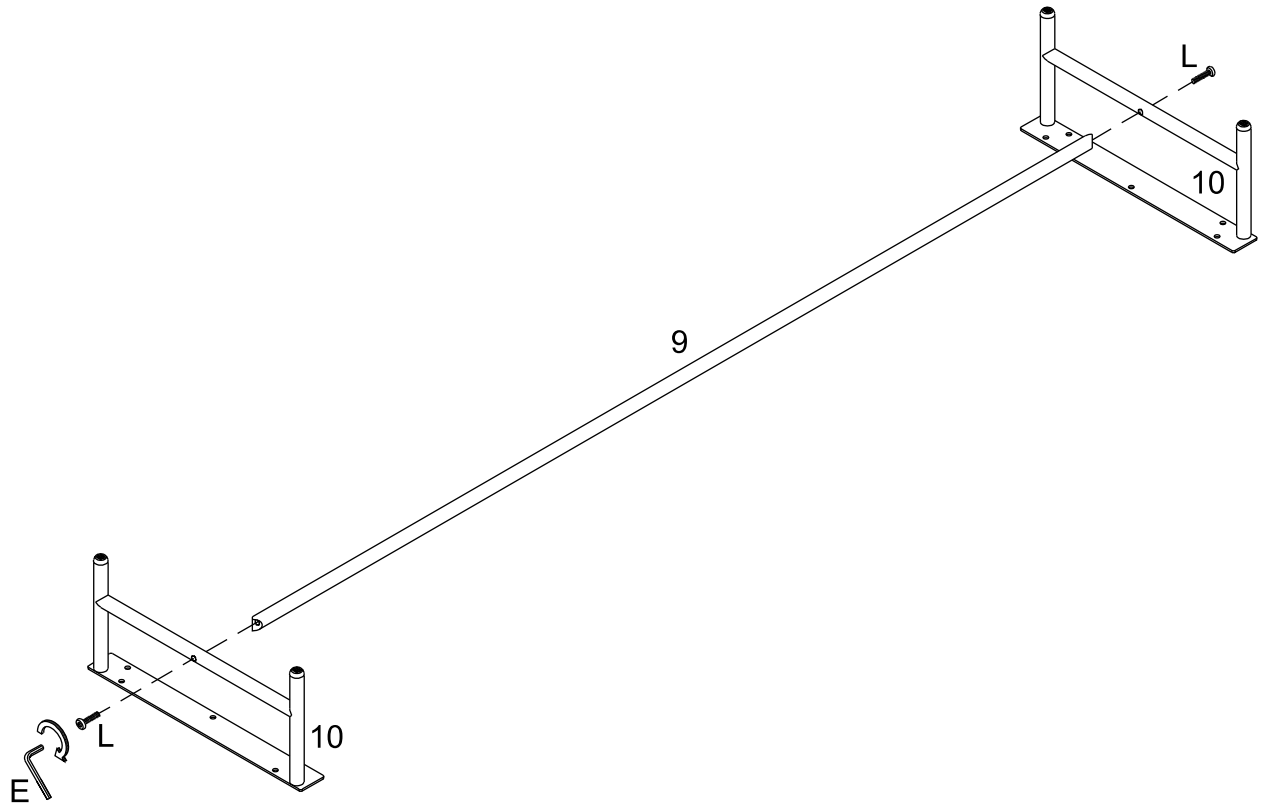

Using Bolt (L) attach part (10) to part (9) with Hex key (E) as per diagram. Note: please do not fully tighten all bolts.

Step 11

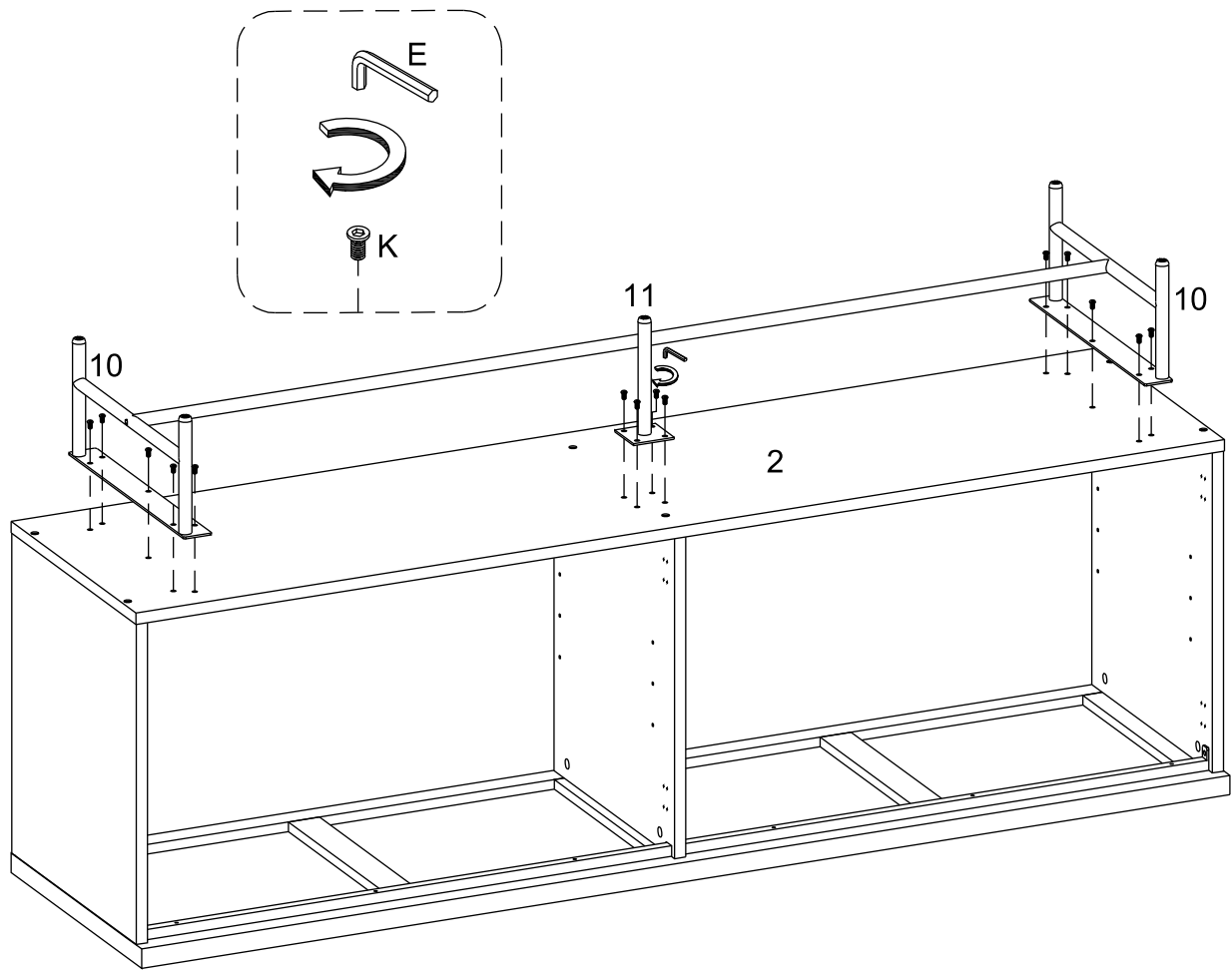

Using Bolt (K) attach part (10,11) to part (2) with Hex key (E) as per diagram. Note: please fully tighten all bolts from Step 10.

Step 12

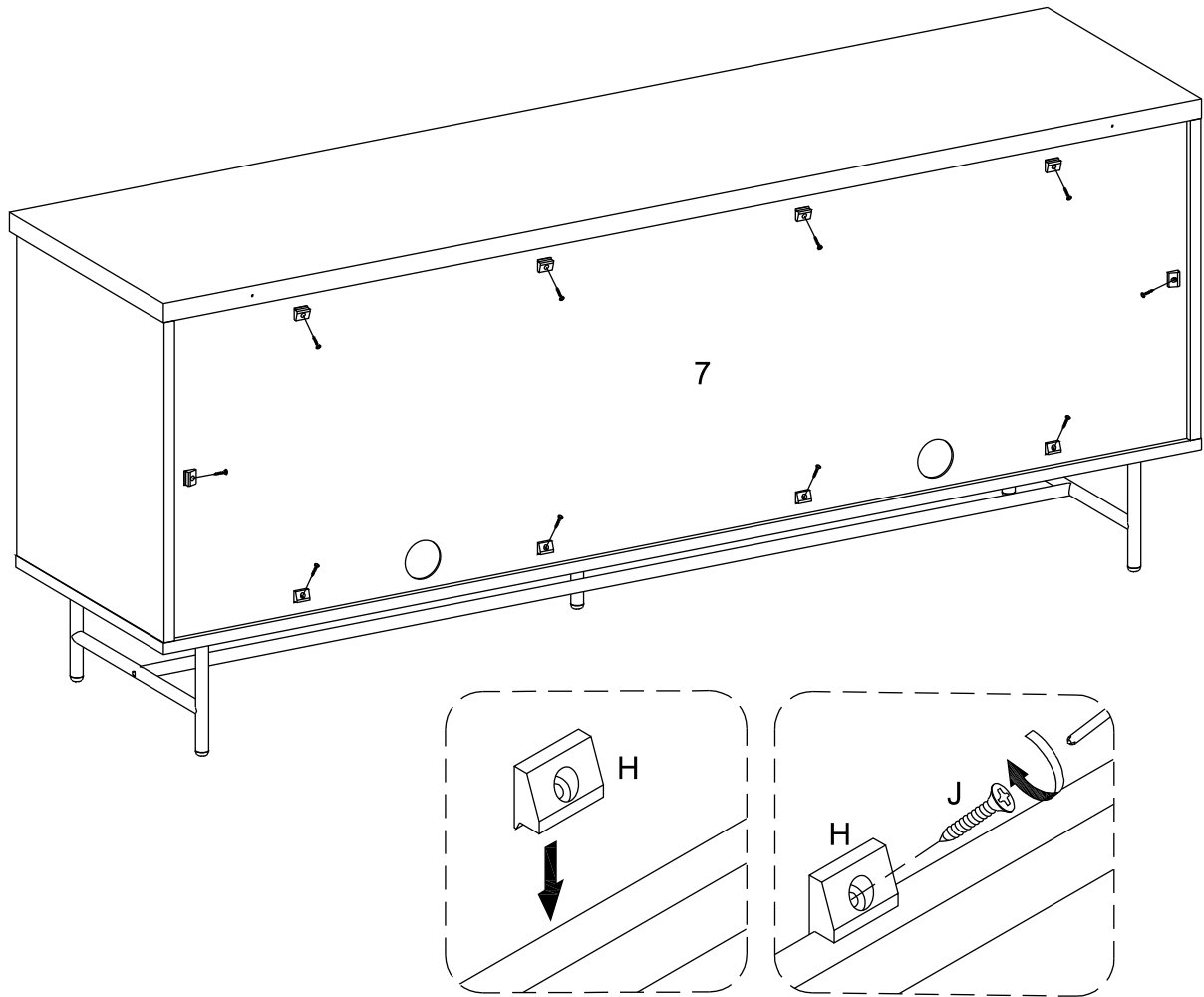

Using Screw (J) attach Plastic Wedge (H) to part (7) with Phillips head screwdriver as per diagram.

Step 13

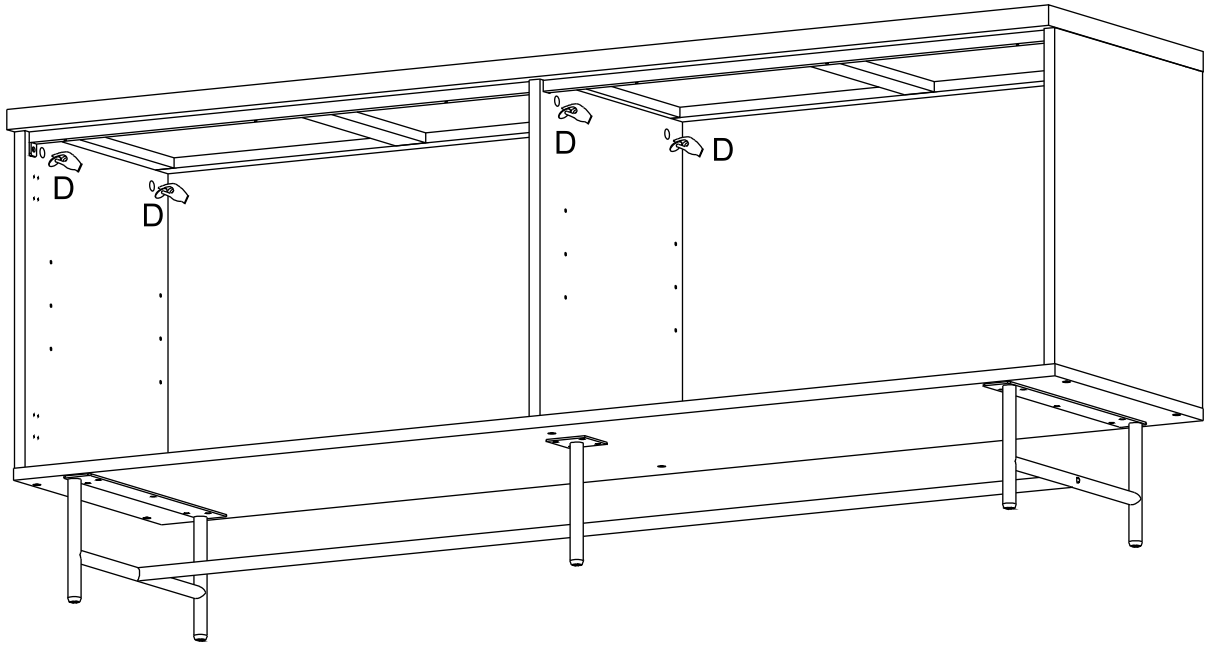

Place Sticker (D) to cover the holes as per diagram.

Step 14

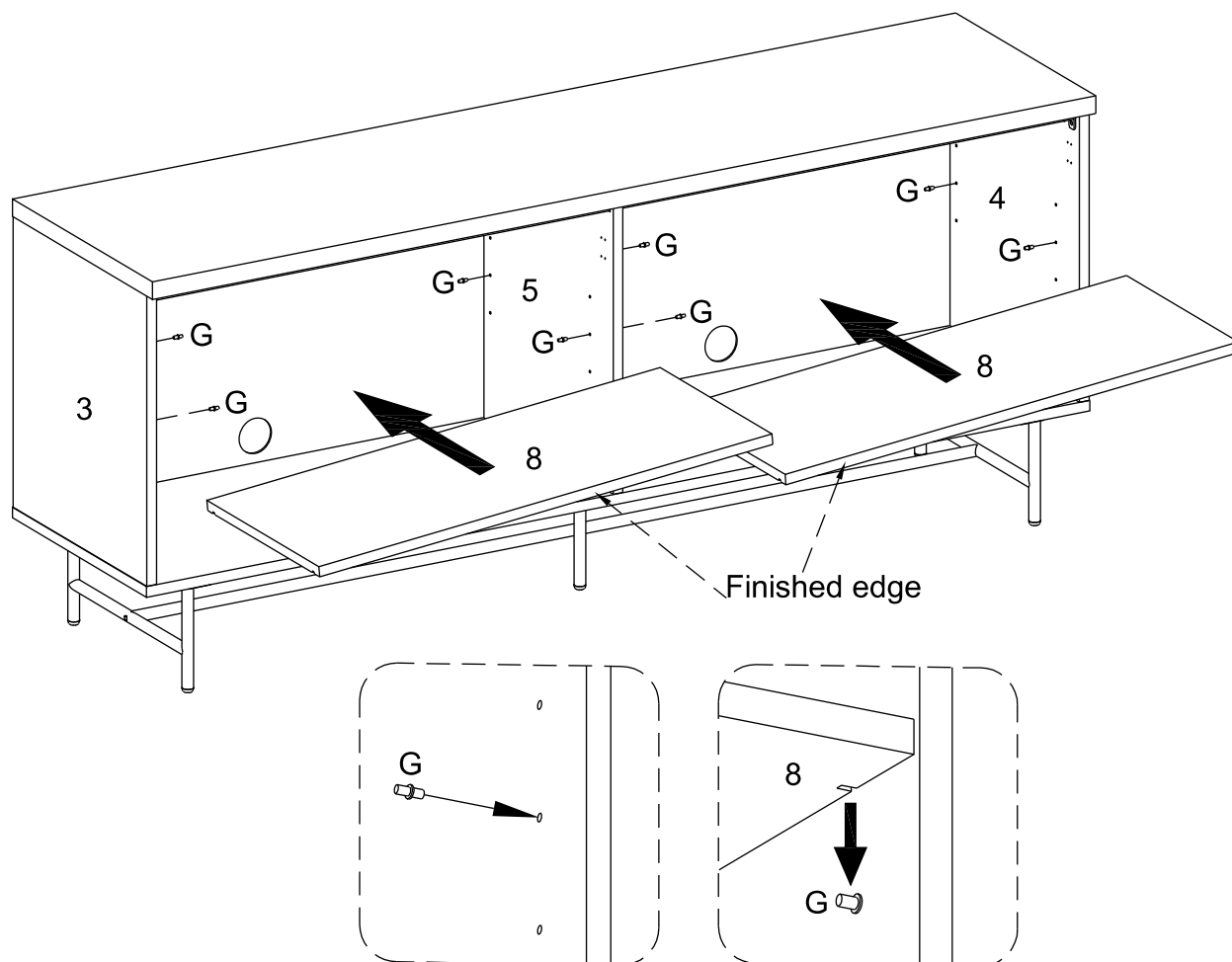

Insert shelf support pin (G) into part (3,4,5) as per diagram. Make sure you place the shelf support pins (G) in the same level. So the shelf is not tilted. Put part (8) into unit as per diagram. Tilt and rest the adjustable shelf (8) onto the shelf support pins .

Step 15

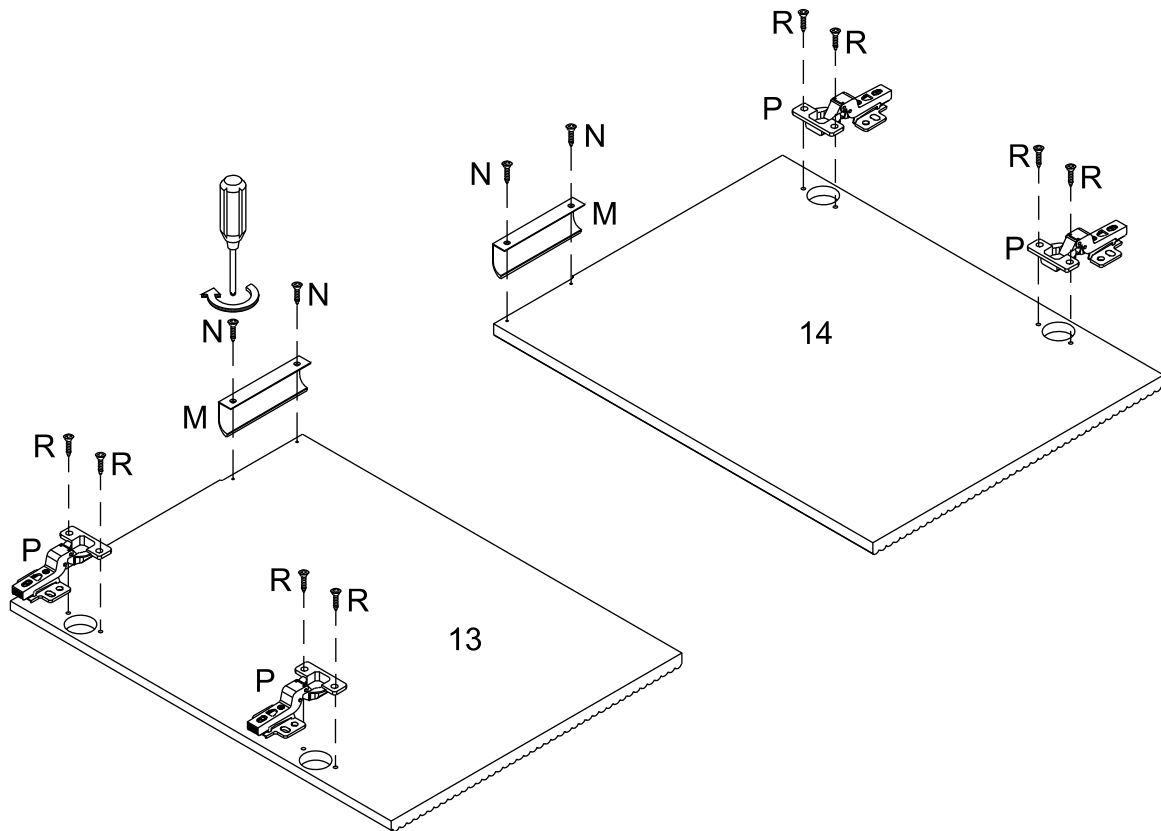

Using Screw (R) attach Europe Hinge (P) to part (13,14) with Phillips head screwdriver, then using Screw (N) secure Handle (M) to part (13,14) with Phillips head screwdriver as per diagram.

Step 16

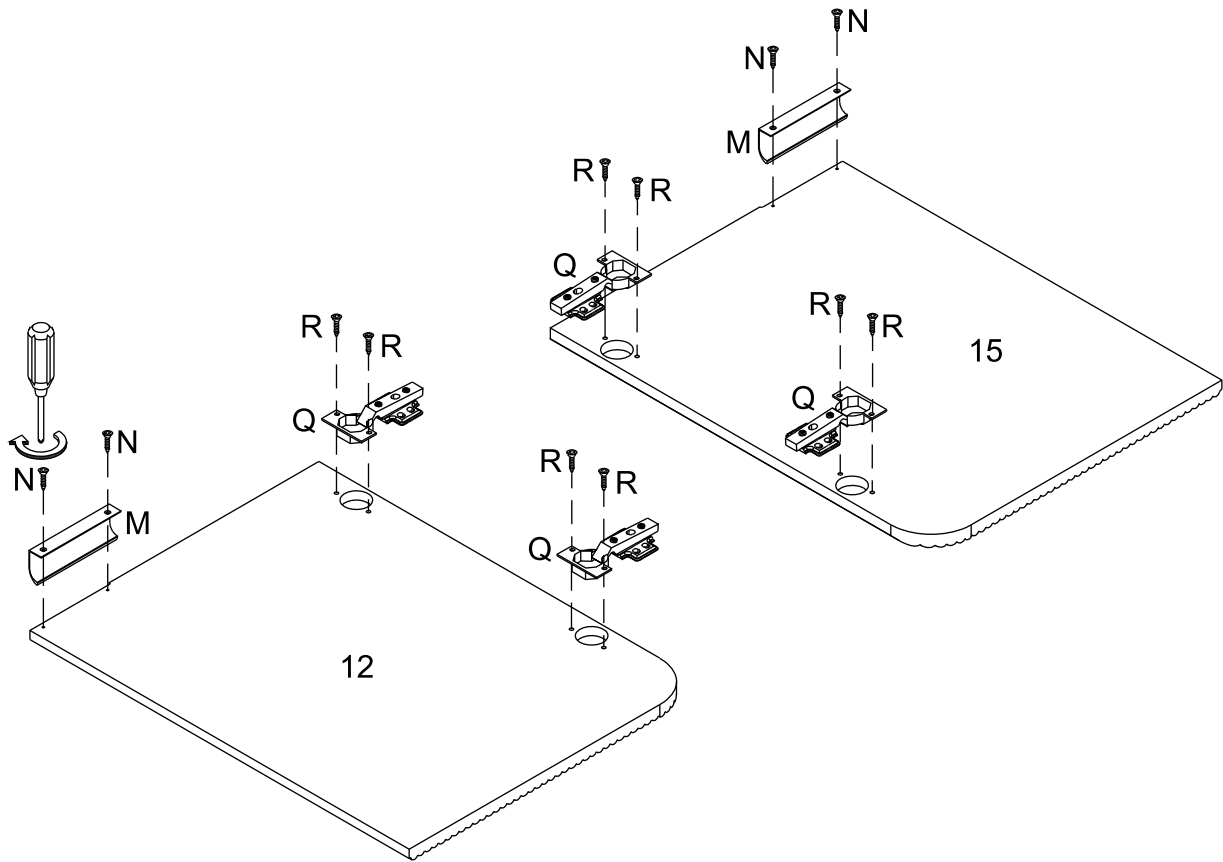

Using Screw (R) attach Europe Hinge (Q) to part (12,15) with Phillips head screwdriver, then using Screw (N) secure Handle (M) to part (12,15) with Phillips head screwdriver as per diagram.

Step 17

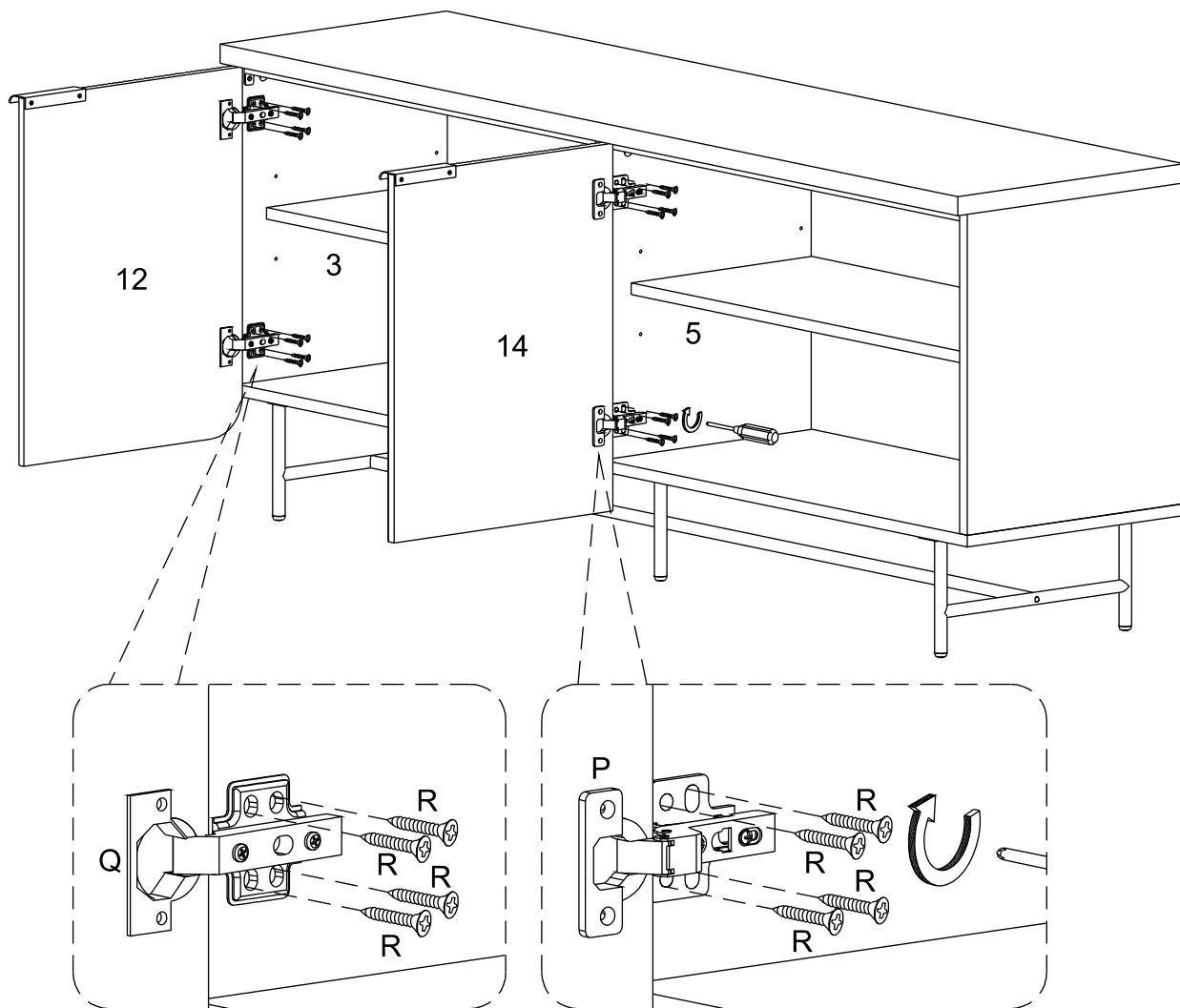

Using Screw (R) attach Europe Hinge (P) on part (14) to part (5) with Phillips head screwdriver, then using Screw (R) attach Europe Hinge (Q) on part (12) to part (3) with Phillips head screwdriver as per diagram.

Step 18

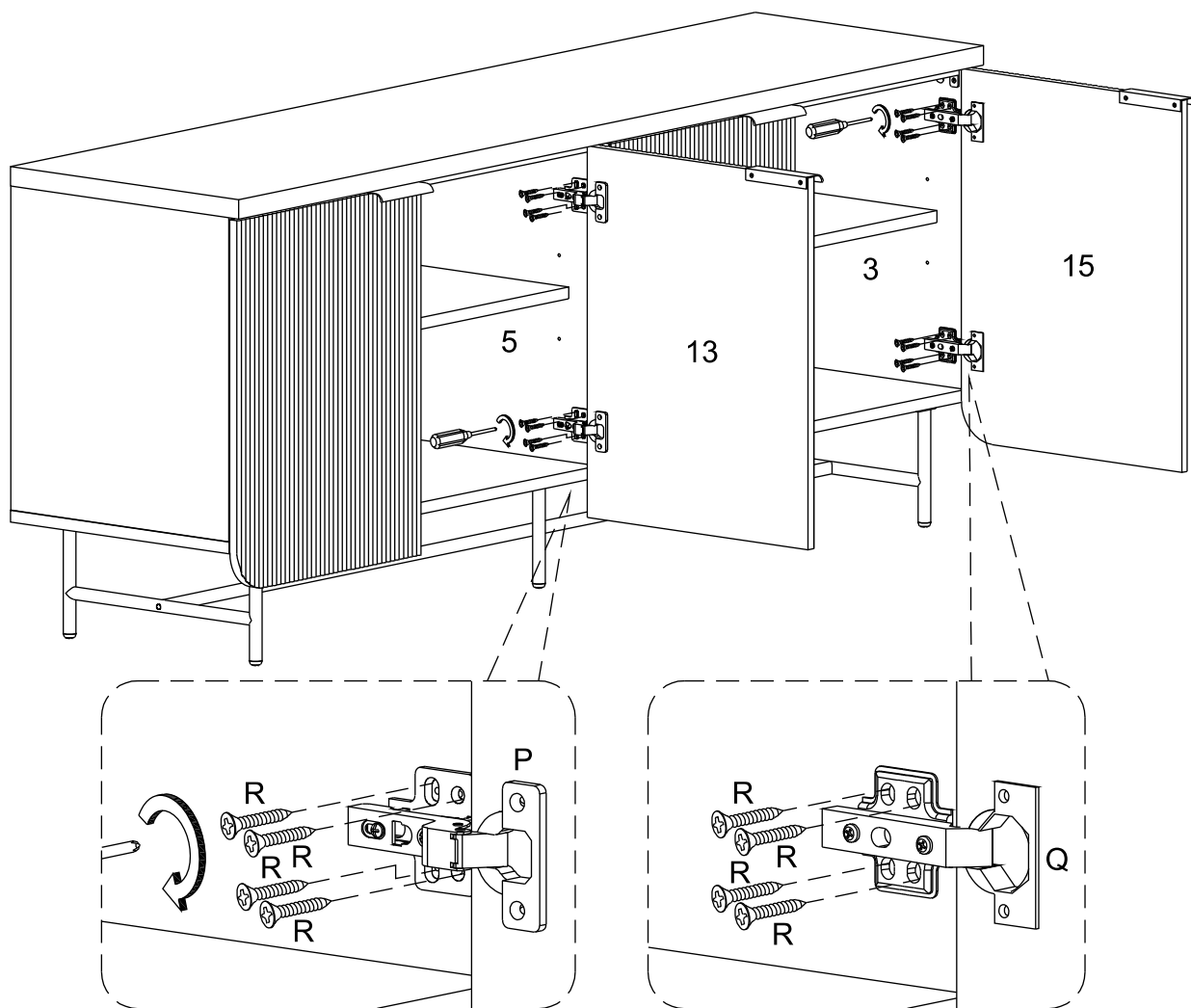

Using Screw (R) attach Europe Hinge (P) on part (13) to part (5) with Phillips head screwdriver, then using Screw (R) attach Europe Hinge (Q) on part (15) to part (3) with Phillips head screwdriver as per diagram.

Step 19

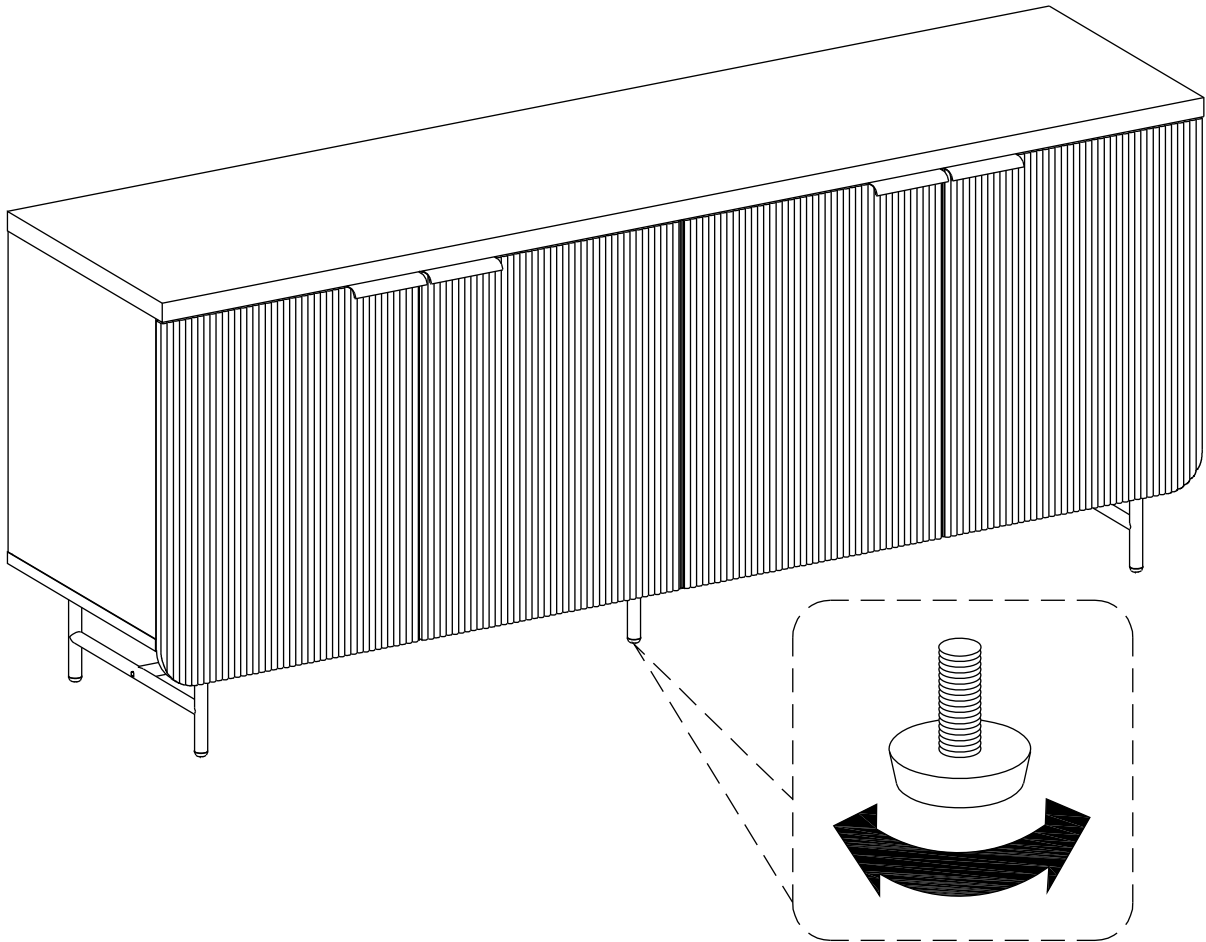

Position the assembled unit at the desired location ,if necessary adjust the floor leveler at the bottom of the leg to level the unit .

Step 20

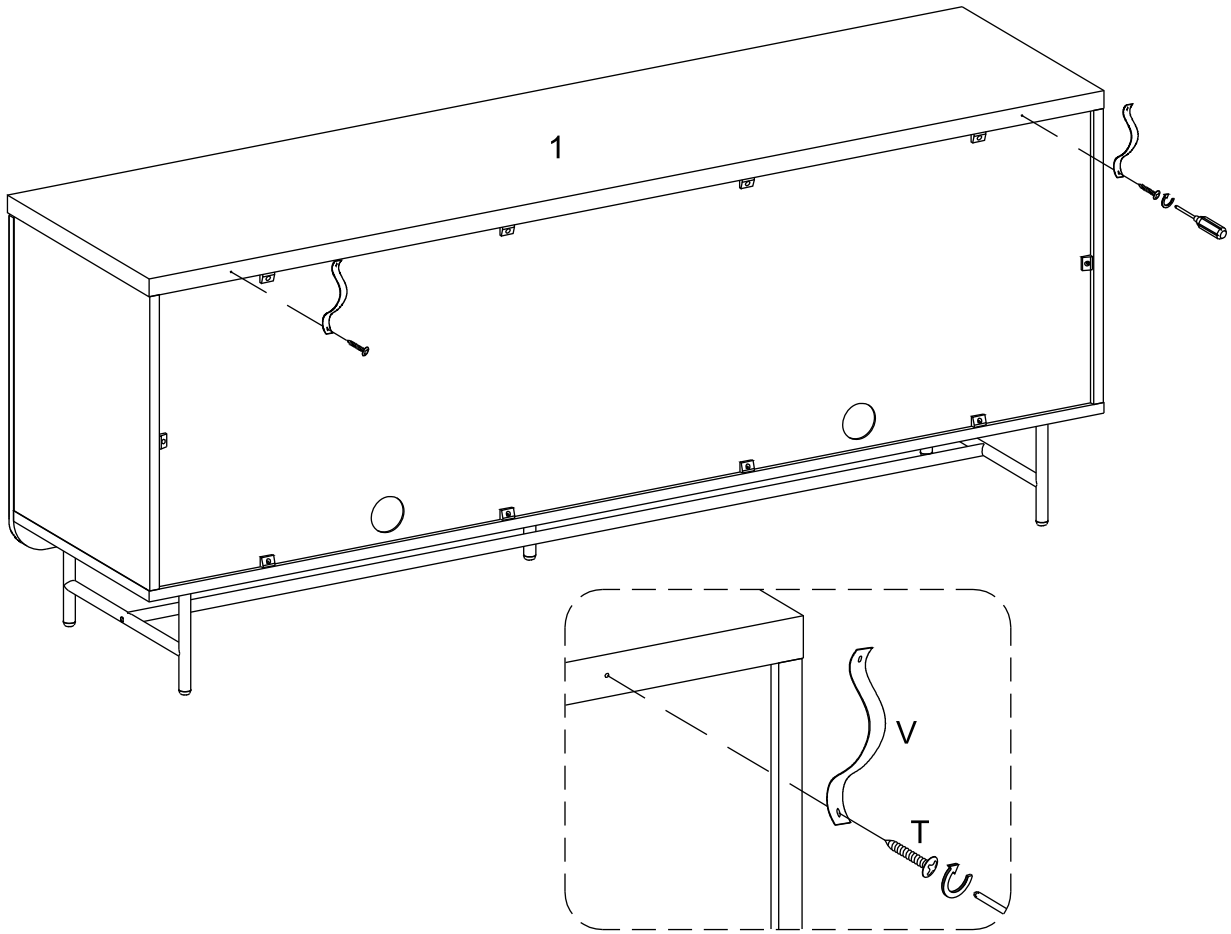

Using screw (T) attach plastic strap (V) to part (1) with Phillips head screwdriver as per diagram.

Step 21

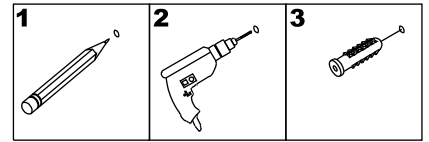

WARNING

Serious or fatal injuries can occur from furniture tipping over. To prevent the furniture from tipping over we recommend that it is permanently fixed to the wall. Wall anchor and hardware are included with this product. Please make sure hardware is suitable for your walls before installing, as different wall materials may require different types of anchors.

Wall

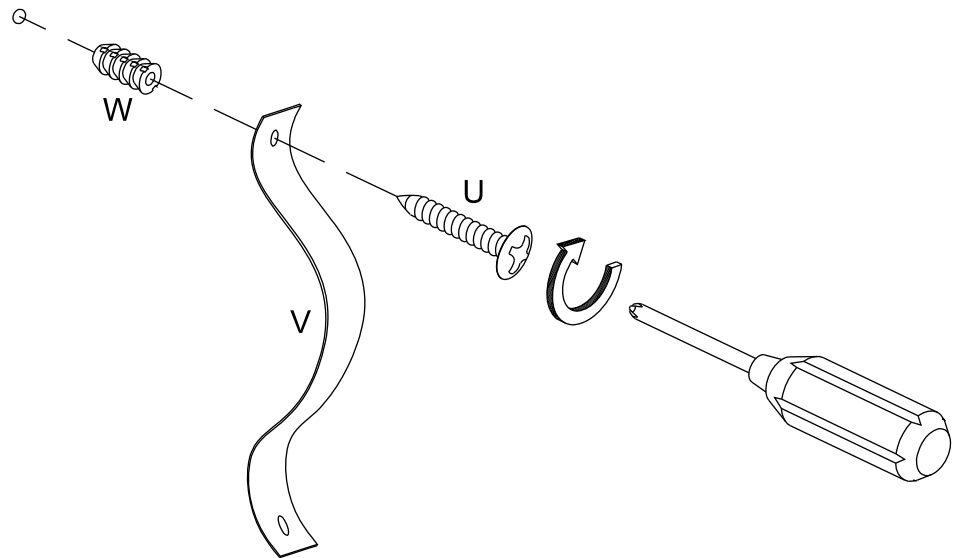

Using screw (U) attach plastic strap (V) and Nut (W) to wall with Phillips head screwdriver as per diagram.

Step 22

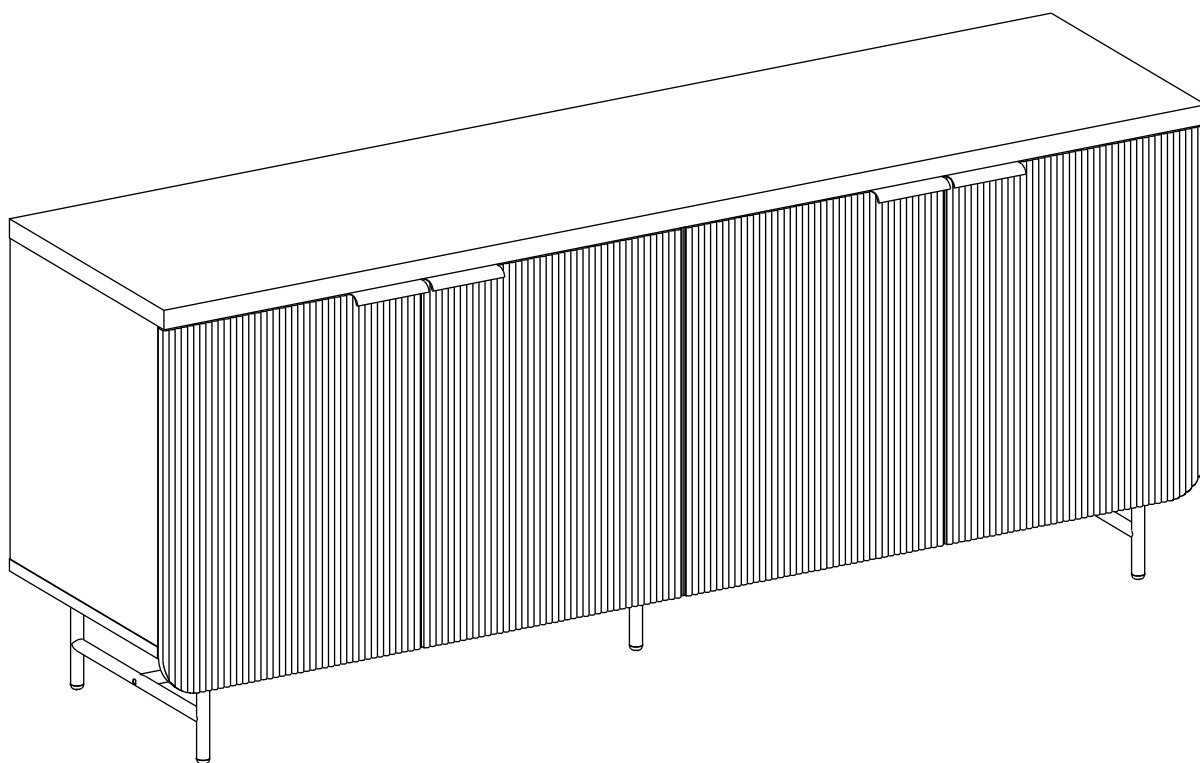

Final Assembly